

Vista[®] and Vista[®] Green

Underground Distribution Switchgear

Guidebook for Commercial & Industrial Applications

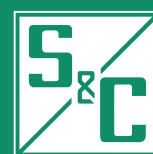
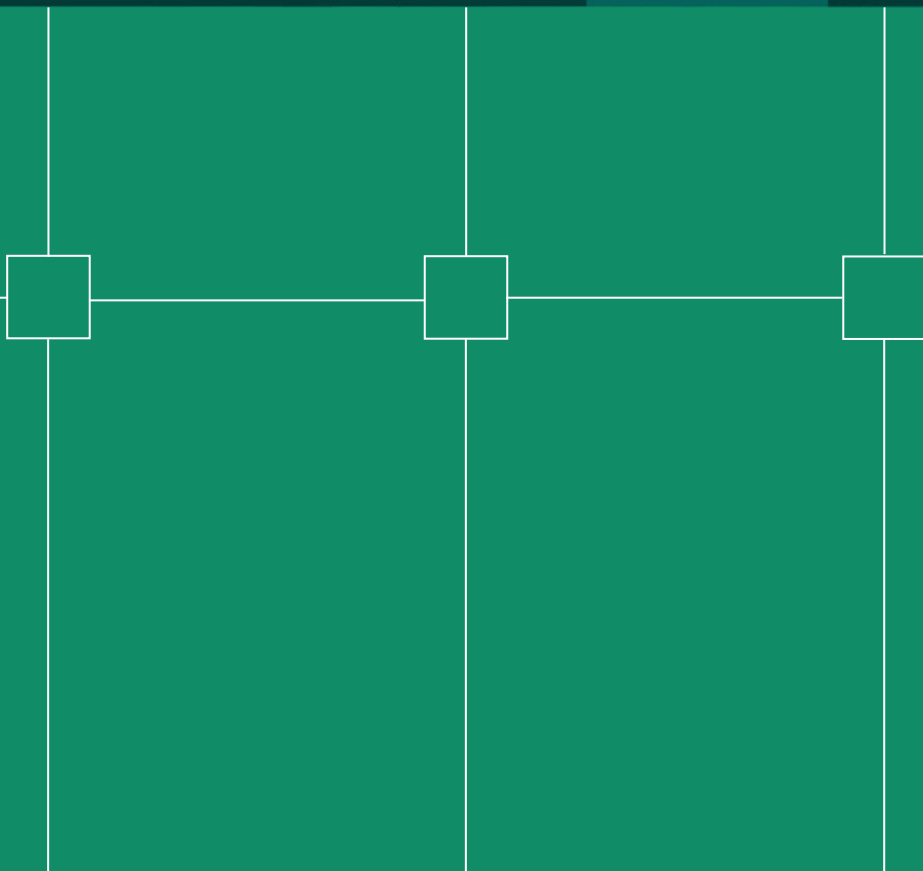

Introduction

Reliable power is vital to everyday operations in commercial and industrial (C&I) facilities. Outages can delay or stop production, damage inventory, and negatively impact profitability and end-customer satisfaction.

And yet the risk of outages is inherent in the design of these C&I facilities' centralized electrical system designs. With business growth always top of mind, these centralized systems limit facility expansion.

If you're trying to solve complex reliability and facility-expansion challenges, defaulting to inflexible system designs and unreliable equipment won't allow you to meet your goals.

This guidebook is designed to help you learn more about alternative system designs and switchgear solutions that can improve your reliability today and support future growth.

Contents

What Problems Do You Need to Solve?	4
Why a Distributed System Is More Resilient than a Centralized System	5
Radial Centralized System vs. Distributed System Alternatives	6
Primary Selective Centralized System vs. Distributed System Alternatives	7
Large-Campus Centralized System: More Complexity and Less Reliability	8
Large-Campus Distributed System: Less Complexity and More Reliability	9
Switchgear Evaluation	10
What Are Vista and Vista Green Underground Distribution Switchgear?	11
How Quickly Do You Want to Restore Power?	12
Switchgear Misconceptions	13
Switchgear Standard Considerations	14
Are Vista or Vista Green Underground Distribution Switchgear Worth the Investment?	15
Switchgear Supplier Evaluation Chart	16
Buying Vista or Vista Green Underground Distribution Switchgear: Who Is Involved?	17
Conclusion	18

What Problems Do You Need to Solve?



Your power reliability isn't getting better.

System designs directly contribute to power reliability. Many C&I facilities have centralized system designs, which lead to longer and more widespread outages, increasing downtime and the potential for significant monetary losses.



You regularly deal with severe weather.

You're used to outages from extreme weather that halt your facility operations. Thunderstorms, earthquakes, and flooding can damage or destroy conventional switchgear lineups, leaving you waiting for weeks or months on repairs or replacements.

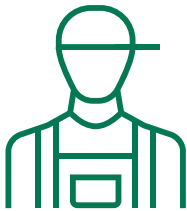

You're short-handed for equipment maintenance.

Conventional switchgear lineups require frequent maintenance. Knowledgeable staff are difficult to come by and require continual training, which increases the potential for reliability and safety consequences caused by mistakes and dangerous arc-flash events.

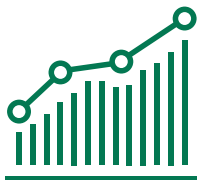

Your facility is expanding, and your existing electrical infrastructure can't support it.

If your facility and energy needs are growing, you may need to eventually transition from low- to medium-voltage utility service. With expansion comes more complexity, such as managing multiple utility sources or effectively distributing power across a large campus. You're unsure whether conventional switchgear lineups can handle system changes.



Your budget can't handle more switchgear lineup expenses.

Although you know the expense of the numerous conventional switchgear lineups necessary to handle the system sophistication you want, you're unsure of other options. This uncertainty may lead to frustration and settling with a less-than-ideal solution.

Why a Distributed System Is More Resilient Than a Centralized System

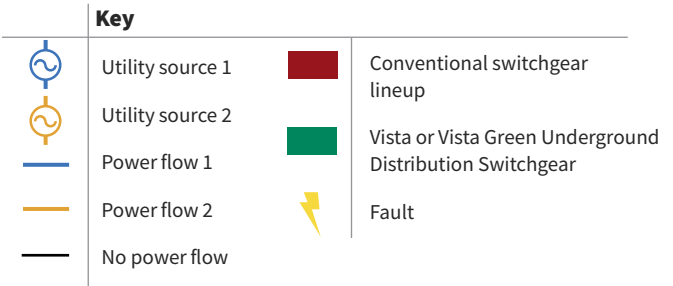

Centralized Radial System

Many C&I facilities make a risky mistake when designing their electrical system: they use a centralized system instead of a distributed design. In a centralized system, there are typically one or two centrally located utility sources and conventional switchgear lineups. Because the entire system is fed through a centralized lineup, the gear has a limited ability to isolate faults. This creates a single point of failure: one fault that can trigger a cascading effect, causing a major outage. All in all, one issue can impact the entire system.

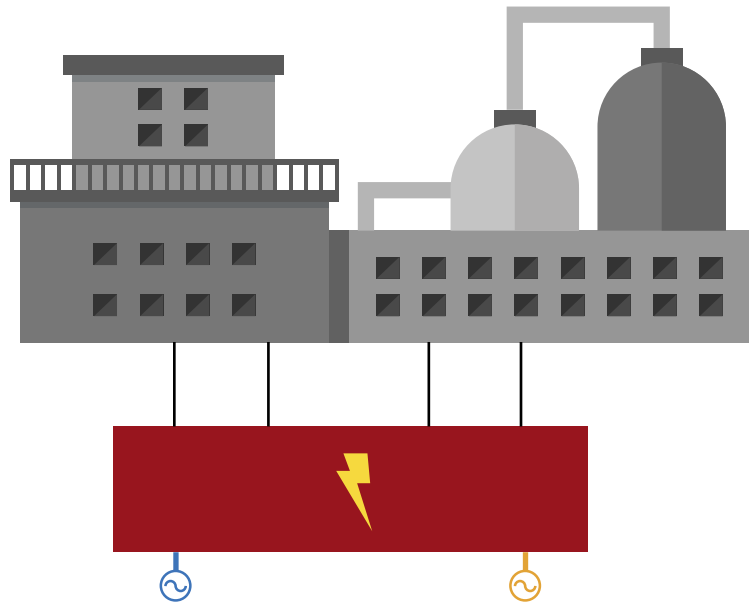

Distributed Looped-Primary System

Distributed systems mitigate centralized design problems by dispersing multiple advanced switching and protection devices throughout the system, supporting the protection strategy that the closer these protection devices are to a fault, the more efficiently they can manage the fault and minimize its impact. When a fault occurs, the devices identify and isolate faults to a smaller part of the system. Moreover, because distributed systems can reroute source power from multiple directions, more power is available to areas that would have been unnecessarily offline otherwise.

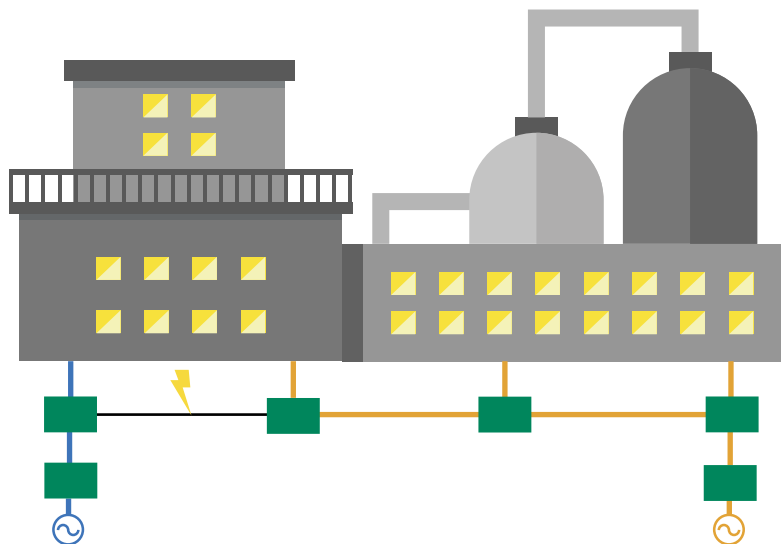

Radial Centralized System vs. Distributed System Alternatives

Radial Centralized System: A Single Point of Power Failure

This system design has one utility source feeding into a large conventional switchgear lineup, where it is divided to feed facility loads. In larger facilities, this lineup is often remote from the served loads to be closer to the utility metering point. If a fault occurs on the lineup, a single point of power failure is created.

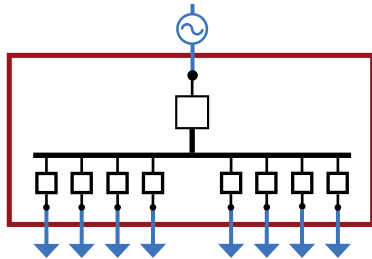

The diagrams below show a common radial centralized system design in contrast to distributed system alternatives. See how a distributed system best meets key design criteria for minimizing outages.

Key			
	Utility source	N.O.	Normally open
	Cable		Switch
	Bus		Fault interrupter
	Conventional switchgear lineup		Tie switch (optional)
	Circuit breaker		Elbow cable termination
	Vista or Vista Green Underground Distribution Switchgear		Stress-cone cable termination

Distributed System Alternatives: Creating Redundancy With Multiple Power Paths

Expanded radial: This system is a budget-friendly way to locate switchgear devices closer to loads. Adding a tie-switch between secondary switchgear (depicted with dashed lines below) can restore loads on one side through loop switching.

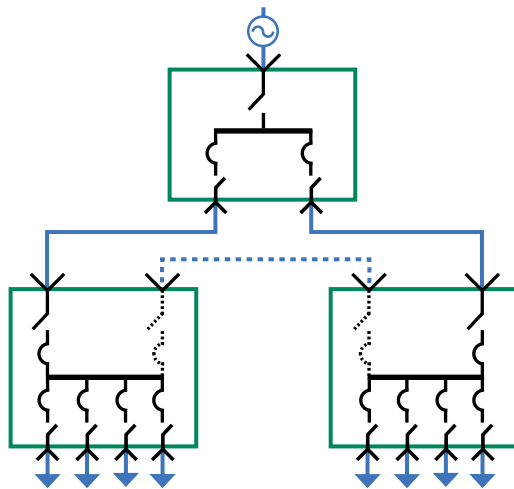

Distributed looped primary: This system combines elements of radial and loop systems using multiple tie switches. A loop is created between discrete switchgear devices, providing a high level of power availability for facilities with widely-dispersed loads.

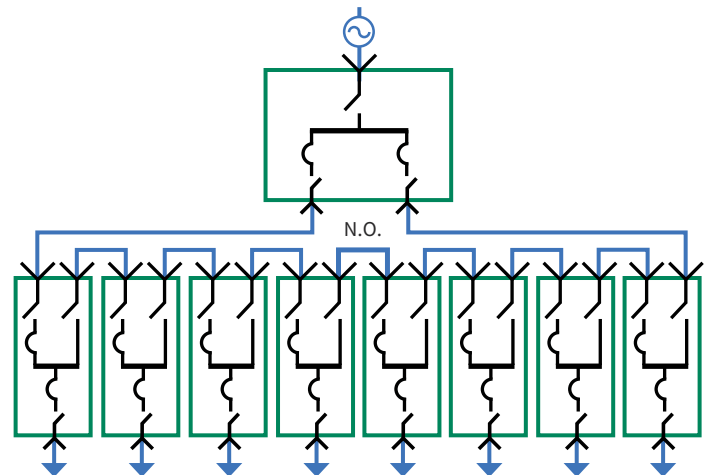

Key Radial System Design Criteria for Minimizing Outages: Three key factors together enable C&I facilities to minimize outages.

System Design Strategy	System Design Type	Proximity of Transformers to Switches <i>Why it matters: The closer these are together, the better the fault protection.</i>	Alternate Power Path <i>Why it matters: Alternate paths mean power can be rerouted to non-faulted areas.</i>	Greater Circuit Segmentation <i>Why it matters: The more segments, the less load loss if an outage occurs.</i>
Centralized	Radial	⚠ Far away	⚠ No alternate path	⚠ Minimal segments
Distributed	Expanded radial	✅ Close together	✅ Alternate path	✅ Many segments
Distributed	Looped primary	✅ Close together	✅ Alternate path	✅ Many segments

Primary Selective Centralized System vs. Distributed System Alternatives

Primary Selective Centralized System: Less Fault Protection and Circuit Segmentation

This system typically has two utility sources, each of which is capable of powering the entire facility. The system typically comprises one conventional switchgear lineup, two primary circuit breakers, a tie breaker, and loop-fed switch and fuse-protection transformers usually located far away from each other. Though this system has two sources, the centralized nature of the lineup means a fault inside the lineup causes excessive load loss.

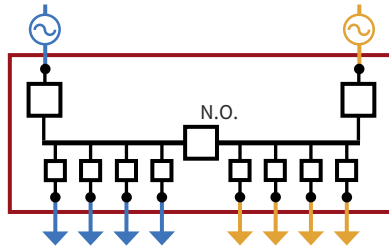

The diagrams below show a common primary selective system design in contrast to distributed system alternatives. See how a distributed system best meets key design criteria for minimizing outages.

Key

	Utility source 1		Conventional switchgear lineup
	Utility source 2		Circuit breaker
	Cable 1		Vista or Vista Green Underground Distribution Switchgear
	Cable 2		Switch
	Bus		Fault interrupter
	Switch control communications path		Motor operator
	Normally open		Elbow cable termination
	Source-transfer control		Stress-cone cable termination

Distributed System Alternatives: Creating Redundancy With Multiple Power Paths

Manual main-tie-tie-main: This system includes a tie switch between two utility sources and two switchgear devices. This is ideal for facilities with multiple utility connection points physically located away from each other.

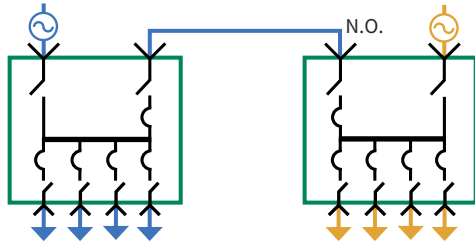

Two-source loop: This system uses multiple tie switches to create a loop between two utility sources and multiple switchgear devices for maximum isolation and service restoration capability.

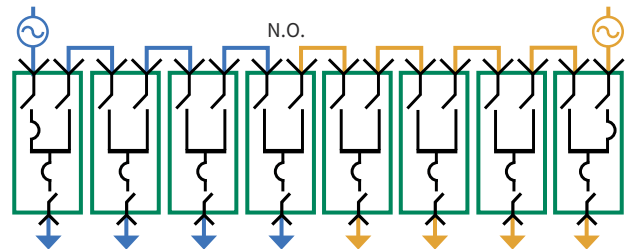

Split-bus automatic source-transfer: This system maximizes uptime through source-transfer automation in the event of a source outage. The system bypasses circuitry to allow complete isolation for maintenance of either automated Vista switchgear unit without requiring an extended outage for any load group. Under normal conditions, this system splits loads evenly between two sources that may be located great distances apart.

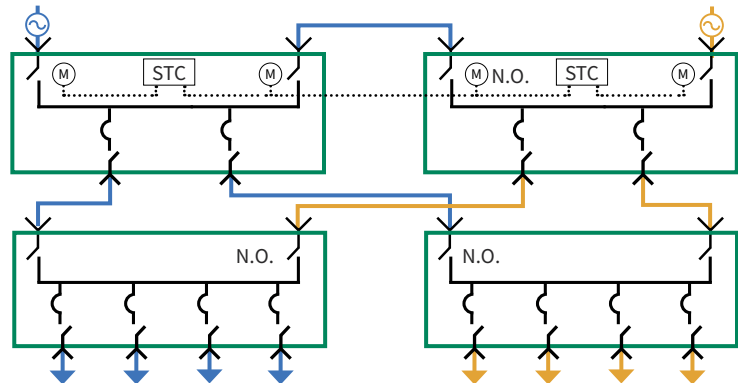











Key Primary Selective System Design Criteria for Minimizing Outages: Three key factors together enable C&I facilities to minimize outages.

System Design Strategy	System Design Type	Proximity of Transformers to Switches <i>Why it matters: The closer these are together, the better the fault protection.</i>	Alternate Power Path <i>Why it matters: Alternate paths mean power can be rerouted to non-faulted areas.</i>	Greater Circuit Segmentation <i>Why it matters: The more segments, the less load loss if an outage occurs.</i>
Centralized	Primary selective	⚠ Far away	✅ Alternate path	⚠ Minimal segments
Distributed	Manual main-tie-tie-main	✅ Close together	✅ Alternate path	✅ Many segments
Distributed	Two-source loop	✅ Close together	✅ Alternate path	✅ Many segments
Distributed	Split-bus automatic source transfer	✅ Close together	✅ Alternate path	✅ Many segments

Large-Campus Centralized System: More Complexity and Less Reliability

This system has two utility sources that may be miles apart and have two or more conventional switchgear lineups. Distribution transformers with loop-feed switches and separate fusing are located away from the lineups. When transformers are far from switchgear lineups, more cables are needed and fault protection is reduced, meaning a campus may see higher system complexity and cost and reduced reliability.

Key	
	Utility source 1
	Utility source 2
	Cable 1
	Cable 2
	Bus
	Distribution transformer with loop-feed switch and fusing
	Simpler distribution transformer
	Conventional switchgear lineup
	Circuit breaker
	Stress-cone cable termination

The diagram below shows a common large-campus centralized system design in contrast to the diagram for a distributed system alternative on page 9. See how a distributed system best meets key design criteria for reducing outages, cost, and complexity by reading the diagrams on this page and page 9.

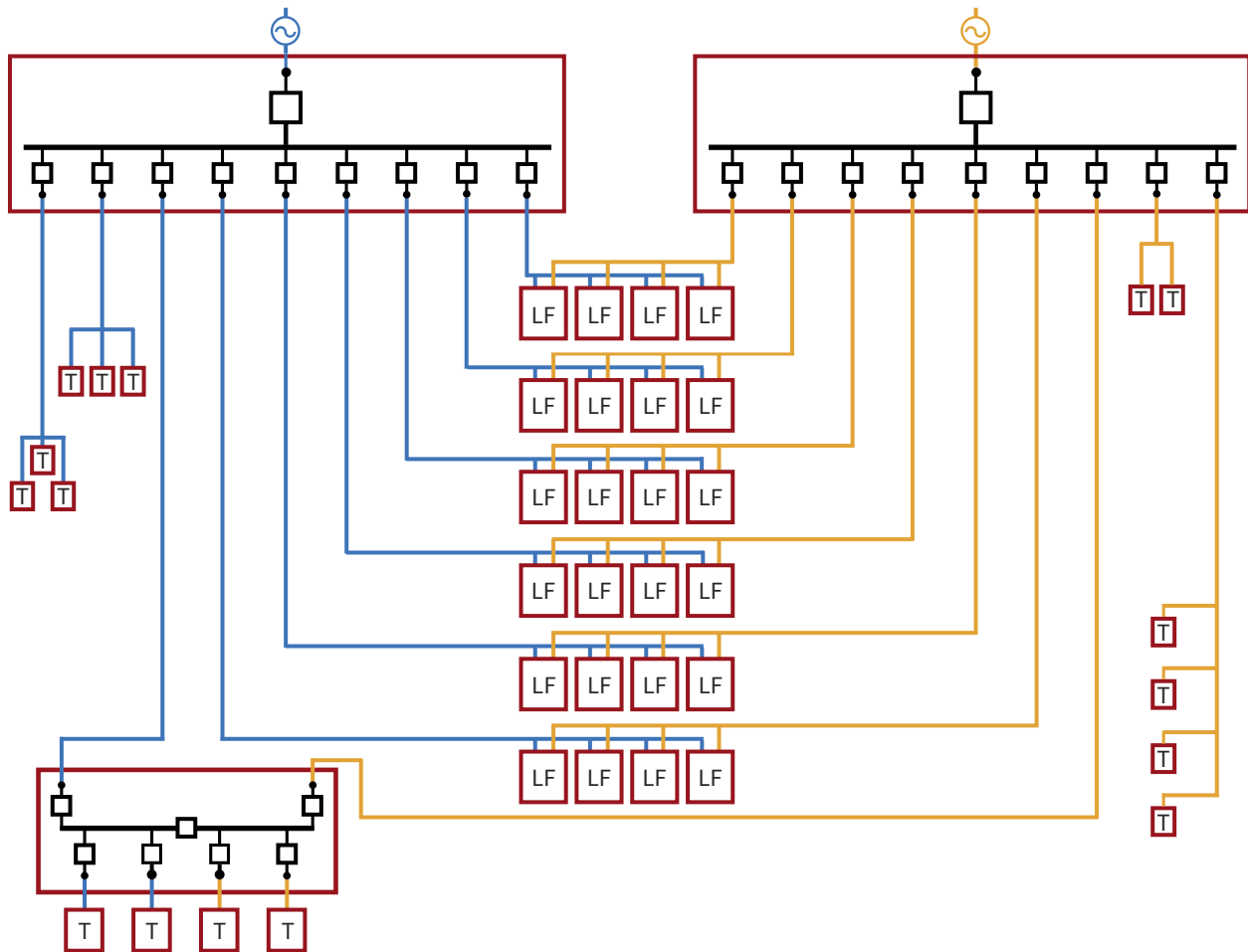

Key Large Campus System Design Criteria for Reducing Outages, Cost, and Complexity: Five key factors together enable large C&I facilities to minimize outages, cost, and system complexity.				
Proximity of Transformers to Switches <i>Why it matters:</i> The closer these are together, the better the fault protection.	Alternate Power Path <i>Why it matters:</i> Alternate paths mean power can be rerouted to non-faulted areas.	Circuit Segmentation <i>Why it matters:</i> The more segments, the less load loss if an outage occurs.	Transformer Type <i>Why it matters:</i> Certain transformer types are more expensive than others.	Cable Requirements <i>Why it matters:</i> Fewer cables means less cost and system complexity.
⚠ Far away	✅ Alternate path	⚠ Minimal segments	⚠ Loop-fed and fuse transformers	⚠ More cables

Large-Campus Distributed System: Less Complexity and More Reliability

This system has two utility sources, two conventional switchgear lineups, multiple advanced switchgear devices, and simpler distribution transformers without loop-feed switches and fuse protection. This system alternative solves the problems inherent to a large-campus centralized system design by enhancing fault protection using fewer cables, which improves reliability while reducing system complexity and cost.

See how a distributed system best meets key reliability, cost, and complexity criteria by reading the table underneath the diagram below.

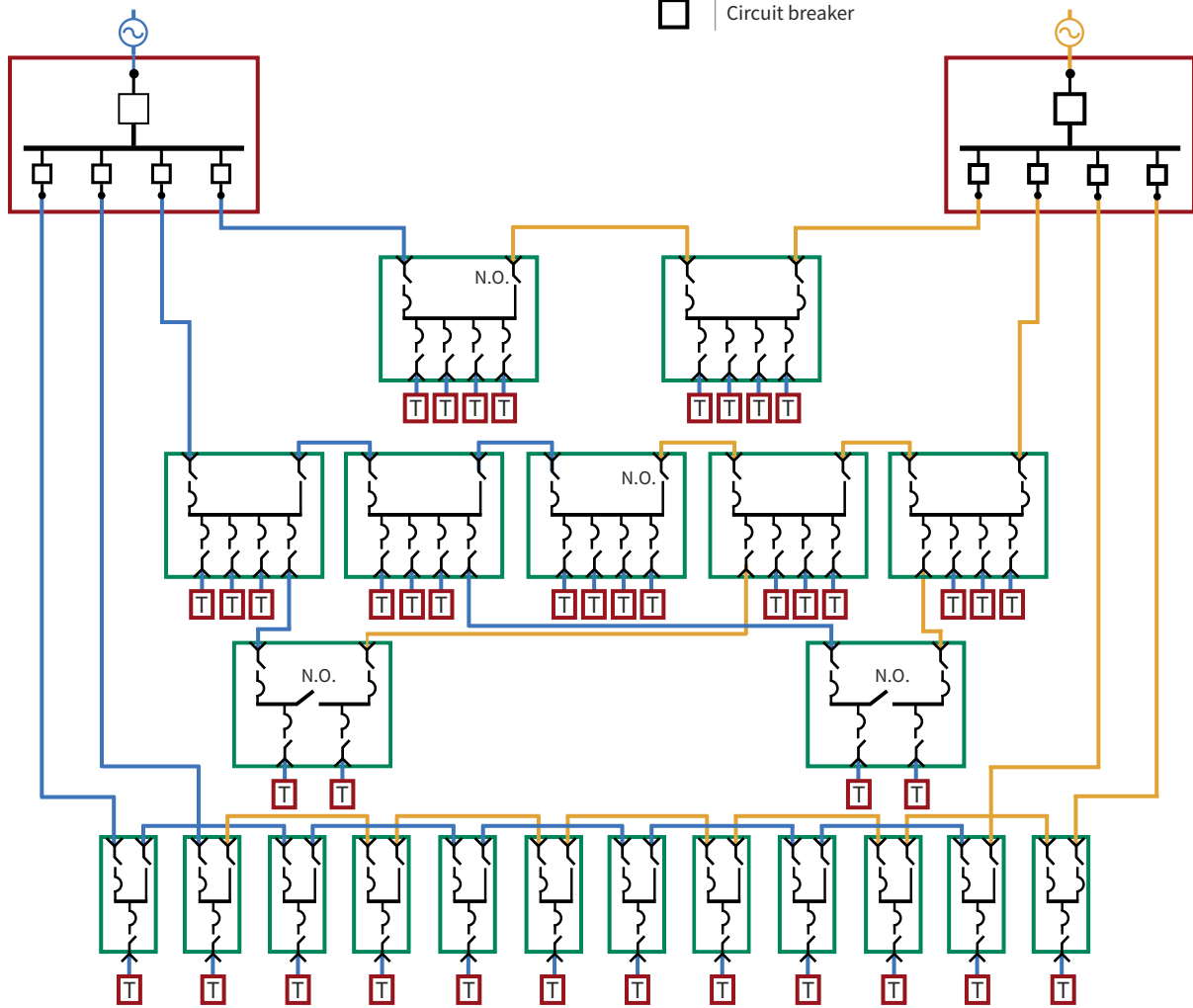
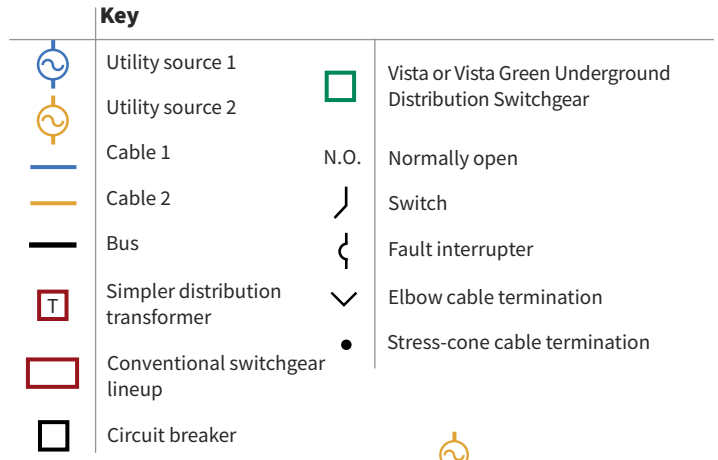

Key Large Campus System Design Criteria for Reducing Outages, Cost, and Complexity: Five key factors together enable large C&I facilities to minimize outages, cost, and system complexity.				
Proximity of Transformers to Switches <i>Why it matters:</i> The closer these are together, the better the fault protection.	Alternate Power Path <i>Why it matters:</i> Alternate paths mean power can be rerouted to non-faulted areas.	Circuit Segmentation <i>Why it matters:</i> The more segments, the less load loss if an outage occurs.	Transformer Type <i>Why it matters:</i> Certain transformer types are more expensive than others.	Cable Requirements <i>Why it matters:</i> Fewer cables mean less cost and system complexity.
Close together	Alternate path	Many segments	Simple transformers	Fewer cables





















Switchgear Evaluation

When you have determined the advantages and disadvantages of various centralized or distributed system designs, you have several switchgear alternatives to consider placing on the system. A distributed system design is most advantageous if switchgear purpose-built for use in distributed systems is applied. Advanced switchgear solutions, such as Vista or Vista Green Underground Distribution Switchgear, support system and facility growth while enhancing reliability and reducing operations and maintenance costs.

Use the following table to evaluate conventional switchgear in contrast to Vista and Vista Green switchgear.

Conventional Switchgear Lineups

Vista or Vista Green Underground Distribution Switchgear

Cons	Pros
 Not economically feasible for distributed system designs	 Supports radial or distributed system designs
 Expensive installation and operations training	 Simple installation and operation
 Additional cost for damage or replacements because of severe weather, such as thunderstorms and flooding, and harsh everyday environments	 Resilient to severe weather, such as thunderstorms and flooding, and harsh everyday environments
 Required electrical house cost for outdoor installations	 No electrical houses needed for outdoor installations
 Wasted money, safety concerns, and higher error margin because of frequent and involved maintenance	 Low maintenance reduces cost, error margin, and safety consequences
 Arc-resistance requires design premium	 Arc-resistance built into gear design
 Bulky indoor installations use valuable facility space	 Compact size saves valuable space
 Need to train more staff on new hands-on lineup maintenance	 Low maintenance gear means fewer staff to train and reduced operations and maintenance cost
 Limits facility and power system expansion plans	 Supports facility and system expansion

What Are Vista and Vista Green Underground Distribution Switchgear?

Vista Underground Distribution Switchgear helps C&I facilities solve reliability challenges on medium-voltage distribution systems up to 38 kV. One unit supports up to six load-interrupter switch and resettable fault-interrupter “ways” and has complete protective coordination that minimizes outages. The switchgear can be operated by one person in a few simple steps and features a sealed design to improve operator safety.

Vista Green Underground Distribution Switchgear is an eco-friendly alternative for C&I companies solving reliability challenges on medium-voltage systems up to 38 kV. This switchgear has the same feature, design, and reliability benefits of Vista switchgear but uses a mixture of CO₂ and C4-FN instead of SF₆ gas. With this alternate gas having a lower CO₂e than SF₆ gas, Vista Green switchgear helps C&I companies meet corporate sustainability goals.

© Vista and Vista Green switchgear are available in multiple installation styles. Visit sandc.com/vistaci to learn more.



Pad-mounted style Vista switchgear®



Did You Know?

A “way” is a compartmentalized section of a Vista or Vista Green switchgear device capable of performing switching and fault interruption for three-phase applications. For example, a “three-way” Vista switchgear unit could support one switch and two fault interrupters, or any combination of these three. Unlike conventional switchgear with a definitive main circuit breaker that supplies power to feeder breakers, each Vista switchgear unit supports up to six fully configurable ways without requiring one to serve as a main breaker.

How Quickly Do You Want to Restore Power?

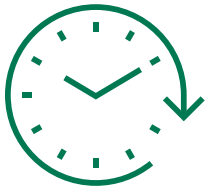

Every C&I facility has different power-restoration needs based on its everyday operational goals. For facilities that heavily depend on power, the quicker power is restored after an outage, the better.

Thinking about how quickly your facility needs power restored can help determine which advanced switching and protection solution would best meet your power-restoration needs.

Average Time for Restoration	30 Minutes ^①			
	Minutes ^②			
	20 Seconds			
	6 Seconds			
Gear Type	1. Source-transfer Vista or Vista Green Underground Distribution Switchgear 2. Advanced relays^③	1. Remote supervisory Vista or Vista Green Switchgear with IntelliTeam[®] SG Automatic Restoration System 2. Advanced relays^③	1. Remote supervisory Vista or Vista Green Underground Distribution Switchgear 2. Advanced relays^③	Vista or Vista Green Underground Distribution Switchgear
System Type	Distributed	Distributed	Distributed	Distributed
Operation Type	Automatic	Automatic	Automatic	Manual
Advantages	Adds automatic primary-selective service capabilities to Vista and Vista Green switchgear	Automatically decides how to best restore power using real-time system data and feeder capacity	Adds remote control and monitoring capabilities to Vista and Vista Green switchgear	Enables localized fault isolation and supports a distributed system design without communications

① The time needed to get in touch with a qualified maintenance crew and their travel time to your site also must be considered when determining the average time for restoration.

② This restoration time varies by user.

③ These are third-party relays with customer logic programmed by S&C.

Switchgear Misconceptions

1. My switchgear lineups are fine.

You've always used conventional switchgear lineups on a centralized system because that's the way it's always been done. However, outages can happen, and now you know your existing gear is vulnerable, which amplifies the problem. C&I facilities are now choosing advanced switching and protection options, such as Vista and Vista Green Underground Distribution Switchgear, to maximize reliability by enhancing fault isolation and power restoration.

2. Vista and Vista Green switchgear are only used by utilities.

Originally, utilities were the principal users of Vista and Vista Green switchgear. However, as their power needs expanded, more C&I facilities took responsibility for their utility interconnection and reliability. With expansion fueling the need for more reliable power, C&I facilities have chosen Vista and Vista Green switchgear to maximize and give them better control over their reliability.

3. If I buy different switchgear, my reliability will get worse.

Buying new equipment that operates differently from your existing switchgear lineups doesn't always jeopardize your reliability. In fact, it can improve it. Vista and Vista Green switchgear operate similarly to breakers by protecting electrical circuits from excess fault current, but with increased circuit segmentation per dollar spent. The ability to enhance fault containment and keep the rest of your facility up and running adds value to the solution.

4. I have standardized on a specific brand and type of metering, relay, or communications platform.

No problem. If your preference is to use SEL devices or some other brand other than S&C, we will design a low-voltage enclosure for your remote supervisory or source-transfer application that incorporates your specified devices.

5. Vista and Vista Green switchgear are too complicated.

Vista and Vista Green switchgear could be misconstrued as complicated advanced technology. However, you know from experience your existing gear is more complicated because of the high maintenance that wastes your time and money, increases error margin, and exposes your staff to arc-flash events. Vista and Vista Green switchgear are purpose-built for simplicity and safety: low maintenance, easy operation, and arc-energy containment.

6. The switchgear lineups supporting my loads can't be replicated by Vista and Vista Green switchgear.

Each Vista or Vista Green switchgear unit can accommodate up to six "ways," meaning it handles more loads than conventional pad-mounted switchgear. If you want to keep larger switchgear configurations, Vista or Vista Green switchgear can be customized to support your design.

7. Switchgear lineups must be large and require an electrical room or a separate electrical house.

Unlike conventional switchgear lineups, Vista and Vista Green switchgear don't need to be next to each other because they support a distributed system design. The greatest reliability improvements are achieved when the switchgear units are placed throughout a system, which also eliminates a single point of failure.

8. I need to buy switchgear lineups and services for low and medium voltage from the same suppliers.

The switchgear supplier you bought lineups and services from in the past may not offer the best solution for reliability and facility expansion. An ideal switchgear supplier provides solutions and services that improve reliability and support facility growth.

Switchgear Standard Considerations



C37.74—Institute of Electrical and Electronics Engineers (IEEE) Standard Requirements for Subsurface, Vault, and Pad-Mounted Load-Interrupter Switchgear and Fused Load-Interrupter Switchgear for Alternating Current Systems up to 38 kV

This principle standard for Vista and Vista Green switchgear includes definitions, ratings, and procedures for performing design and production tests, as well as construction requirements for subsurface, vault, and pad-mounted load-interrupter and fused load-interrupter switchgear.



Canadian Safety Association (CSA) and UL Standards

Unlike dry-type transformers or other indoor standard electrical equipment, there are no UL standards for Vista or Vista Green switchgear. However, an authority having jurisdiction may want to inspect your switchgear for a nationally recognized testing laboratory (NRTL) mark. If you're working with an expert supplier, it can provide a CSA equipment inspection when a NRTL mark is needed.



National Electrical Manufacturer's Association (NEMA) and (IP)—Environmental Standards

These standards define switchgear protected from rain and accidental human contact. Vista and Vista Green switchgear are submersible beyond the standards defined by NEMA or IP. Vista and Vista Green switchgear tanks are submersible to more than 3 meters (9.8 feet). This means the switchgear performs significantly better over indoor gear in extreme weather events, such as flooding. The switchgear units also have protective locking and access restriction in case untrained persons encounter them.



International Electrotechnical Commission (IEC) 60298 (IEC 62271-200)—Arc Flash Standard

This standard defines how switchgear should perform in an internal arc-flash event. Vista and Vista Green switchgear's sealed tank designs are tested to mitigate dangerous internal faults.



Pro-Tip

Global standards for switching and protection equipment for C&I applications may vary. An expert supplier will be able to help you determine which standards apply to the equipment in your region.

Are Vista or Vista Green Underground Distribution Switchgear Worth the Investment?



It's important to consider the value of Vista or Vista Green switchgear in comparison with other options through four key elements of your facility's success:

Key Elements	What You Know	What to Consider	Response (fill in the blank)
Operation and Maintenance Cost	Conventional switchgear lineups require frequent maintenance, which can contribute to routine downtime. The more lineups you buy, the more staff you'll need to maintain them.	How much in maintenance expenses will we have for our switchgear lineups?	
		Will we always have trained specialists on staff or service contracts to maintain our switchgear lineups?	
		Have the options we're considering proven their value to other facilities by significantly lowering operations and maintenance costs?	
Facility Expansion	Business growth is always an objective, so expanding your facility may soon become a reality as your brand and customer base grows. However, with conventional switchgear lineups supplying power from a far corner of your site, you may wonder how powering new buildings is possible.	How many more switchgear lineups will we need to buy to keep up with expansion efforts?	
		How much space would we free in our facility if we found compact equipment that could be kept outdoors?	
		Are the solutions we're looking into flexible enough to be placed on our system wherever critical power is needed?	
Reliability	The reality is, your expanding facility will likely experience outages in the future because conventional switchgear lineups aren't built for system growth. If the lineups were hurting your productivity from day one, they will also do so in the future, when your facility needs even more power.	If there's an issue on our system, how much of our facility would lose power if we're using conventional switchgear lineups?	
		How critical is reliable power to new areas of our facility?	
		How much money will we lose if we use lineups in new buildings and there are reliability issues?	
Restoration Time	If your conventional switchgear lineups are damaged or destroyed, it may take some time to figure out what went wrong. If your power can't be restored quickly, what will the downtime cost you?	What impacts would outages lasting a minute, or even seconds, have on our facility?	
		How long of an outage are we willing to tolerate?	
		What are the fastest restoration options available to us?	



Switchgear Supplier Evaluation Chart



Choosing a switchgear supplier with mastery in key competencies is critical to a successful project.

As you're researching different options, add each supplier to the chart below. Rank them on a scale of 0 (no capability) to 3 (full capability) in each competency. The one with the highest score reveals the most capable switchgear supplier.

Competency	Supplier 1	Supplier 2	Supplier 3
<p>Medium-Voltage Expertise A medium-voltage equipment supplier is also a systems expert that provides the best advice on improving reliability holistically, integrating the ideal switching and protection solutions seamlessly. A conventional switchgear supplier can be a generalist that carries low-voltage design principles into medium-voltage design. What level of expertise does the supplier have with medium-voltage equipment and systems?</p>			
<p>Custom Engineering Your system is unique. However, not all suppliers have custom engineering services to design new switchgear specifically for your facility's needs. Can the supplier tailor your switchgear to meet system requirements? If customization isn't available, has the supplier shared an alternate solution?</p>			
<p>Utility Interconnection Knowledge A supplier knowledgeable in utility interconnections streamlines the utility-agreement process to get new utility sources connected to your system and new switchgear energized sooner. If your supplier hasn't worked extensively with your utility, you could face delays and fees. Has the supplier helped other facilities interconnect their systems and switchgear with your utility? Are they familiar with the type of protection your utility uses in order to properly coordinate devices?</p>			
<p>Education and Training New equipment can be intimidating, especially if you're phasing out existing gear, redesigning your system, or upgrading your system to medium voltage. Will the supplier expertly train your staff and make you confident in owning your new solution?</p>			
<p>Long-Term Support Switchgear-integration support doesn't end after energization. You may need support from your supplier to monitor the device, fix issues, and answer questions. Can the supplier remotely monitor your switchgear after energization? Does the supplier offer support after energization? How quickly can your supplier respond to challenges?</p>			
<p>Experience, Reputation, and Trust A reputable supplier that successfully completed past switchgear-integration projects with other facilities is a strong indicator of who to trust with your project. Do you trust and think you'll enjoy working with the supplier? Does the supplier have multiple examples of successful project stories that prove their users' trust in them as a project partner?</p>			

Buying Vista or Vista Green Underground Distribution Switchgear: Who Is Involved?



Title	Role	Motivation	Potential Questions	Answers
Internal or External Engineers	Provide electrical engineering expertise	Design an optimal system within budget	Does the gear have a reputation for high quality and reliability? How does the gear function? Who will help us specify the gear for our needs?	Major users of Vista and Vista Green switchgear are critical C&I facilities, military bases, and utilities. The switchgear functions similarly to conventional switchgear lineups, was designed with safety and simplicity in mind, and meets rigorous quality standards. An expert switchgear supplier can help you explore design solutions flexible to your system needs and within budget.
Facility Owner or Operator	Maintains and operate facility	Maximizes uptime	What will the gear's maintenance costs be over time? How will the gear affect my uptime or downtime? Will my team need to learn new technology, and will they understand how to operate it?	Valuable switchgear lowers operation and maintenance costs, improves reliability, and decreases downtime. A supportive switchgear supplier will transfer knowledge and train your team to confirm they understand the gear.
Building Architects	Design facility buildings	Maximize usable space	How will the gear look outside or inside my building? What is the supplier's reputation installing the gear?	Vista and Vista Green switchgear are durable and have multiple installation styles that enable indoor or outdoor installation to meet aesthetic requirements or preferences. A trusted supplier has an extensive installed base in a multitude of C&I environments.
Chief Executive Officer or Board of Directors	Considers long-term facility goals and approves decisions supporting them	Maximizes profitability	How does Vista and Vista Green switchgear align with and support our business goals? How does the gear benefit us from a competitive standpoint?	Vista and Vista Green switchgear aligns with business goals by keeping your facility up and running, supporting your facility's growth, and helping you meet corporate sustainability goals. Having a resilient system means minimal interruption to work—and the revenue it brings in.
Chief Financial Officer	Manages finances	Maximizes revenue and minimizes expenses	Is Vista or Vista Green switchgear more expensive than alternative gear? Will the return on investment (ROI) justify the gear purchase?	When strategically placed on a system, the gear effectively mitigates outages by restoring power quickly, even within seconds. S&C has deep expertise in medium-voltage critical-facility solutions across military bases and data centers of all sizes, types, and complexities.
Information Technology Director	Oversees data center or Information Technology operations	Maximizes uptime	Can the gear restore power automatically and, if so, in what time? How experienced is the supplier with data-center design and operations?	When strategically placed on a system, the gear effectively mitigates outages by restoring power quickly, even within seconds. S&C has deep expertise in medium-voltage critical-facility solutions across data centers of all sizes, types, and complexities.



Conclusion

The far-reaching outages, downtime, and delayed power restoration inherent to a centralized system design, and the conventional switchgear lineups on it, are no longer a reality C&I facilities must accept.

Advanced switching and protection options exist that support a distributed approach to power delivery and solve these problems so you can focus on business goals instead of bracing for the next outage.

To learn more about how a distributed system design and Vista and Vista Green Underground Distribution Switchgear can be advantageous to your facility, reach out to S&C for support optimizing your system design. We're here to help.





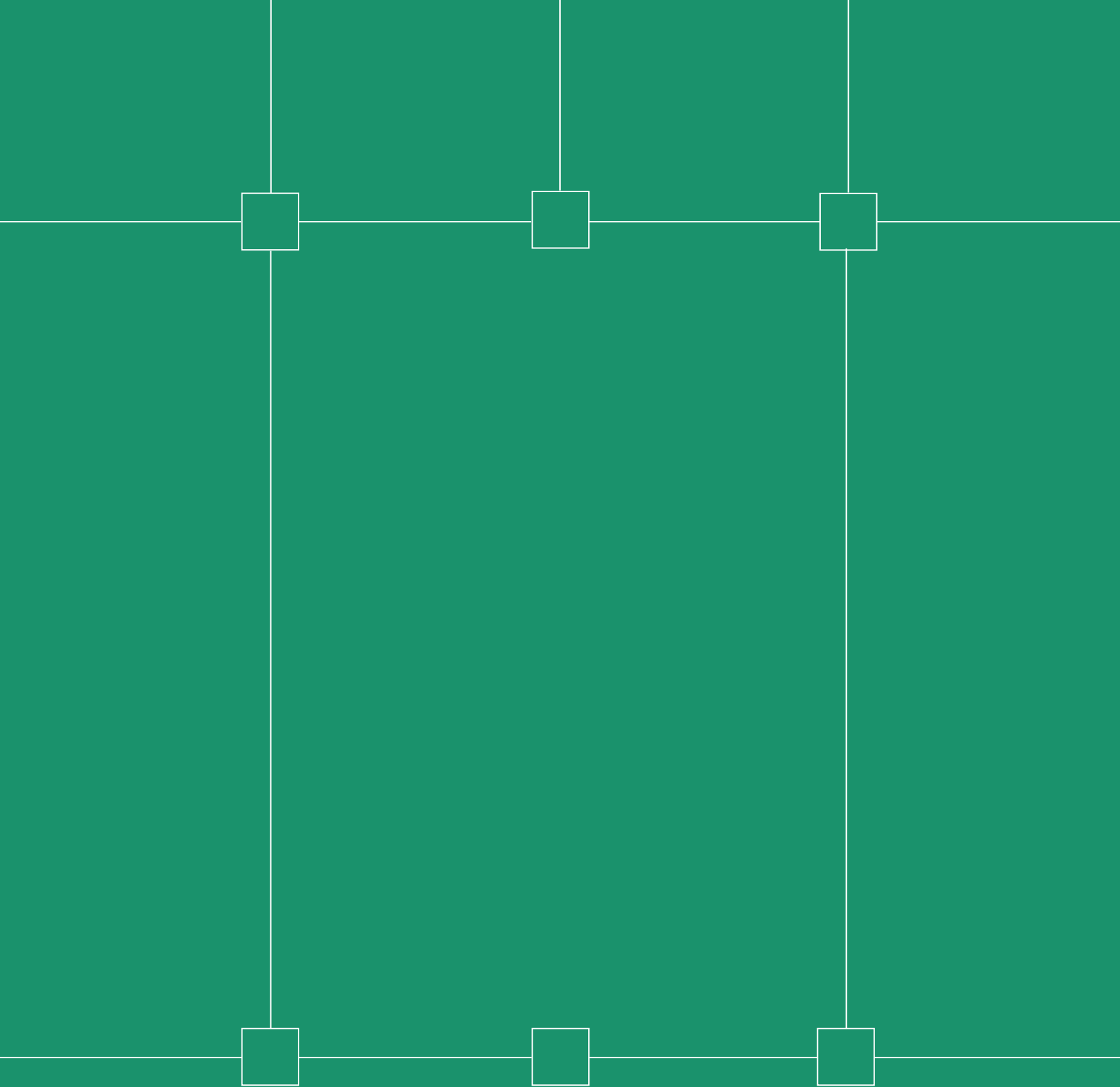

680-4501 • 062226

© S&C Electric Company 2020-2026. All rights reserved

