

Specifications

Table of Contents

Conditions of Sale	2	How to Order	5
Standard.....	2	Ratings Tables	6
Special to This Product.....	2	Ordering Tables	7
Warranty Qualifications.....	4		



Standard

The seller's standard conditions of sale set forth in Price Sheet 150 apply, except as modified in the "Warranty Qualifications" section on page 4.

Special to This Product

Inclusions

S&C Manual PMH Pad-Mounted Gear features directly operable accessible components. Switches and fuses are clearly visible. Manual PMH models contain 600-ampere external handle-operated Mini-Rupter® Switches for three-pole live switching of three-phase source circuits and 200-ampere hookstick-operated S&C Power Fuses with Uni-Rupter® Interrupters for single-pole live switching of single-phase or three-phase load circuits. (These models offer a choice of S&C Type SML-20 and SML-4Z Power Fuses or Fault Fiter® Electronic Power Fuses. Fault Fiter Electronic Power Fuse mountings also accommodate a variety of single-barrel current-limiting fuses listed in Table 1 of S&C Information Bulletin 660-50.)

Enclosures meet the requirements of ANSI C57.12.28 (enclosure integrity). They are of free-standing, self-supporting construction—not for bolting directly to transformers—with provisions for cable entrance and exit through the bottom. Access to medium voltage is controlled by the Penta-Latch® Mechanism, which provides automatic door latching and permits padlocking only when the door is securely latched. The door can be opened only with a pentahead socket wrench or tool.

The enclosure roof is undercoated with an insulating "no-drip" compound. A resilient closed-cell gasket on the enclosure bottom flange protects the finish from being scratched during installation and isolates it from the alkalinity of a concrete foundation. Enclosures are protected from corrosion by S&C's olive green Ultradur® II Outdoor Finish.

A dual-purpose front barrier of fiberglass-reinforced polyester is provided for each switch and fuse. Where the National Electric Safety Code (ANSI Standard C2) applies, these barriers meet the requirements of Section 381G.

When the switch or fuse is in the **Open** position, this barrier can be inserted into the open gap to guard against inadvertent contact with live parts. Interphase and end barriers of the same material are provided with each switch and each set of fuses where required to achieve published BIL ratings. Additional barriers of fiberglass-reinforced polyester separate front and rear compartments and isolate the tie bus (where furnished). Full-length steel barriers separate adjoining compartments (where applicable).

These PMH models are provided with a Grappler™ Handling Tool, if applicable; an instruction manual holder; and storage racks in the fuse-compartment doors for spare S&C Fuse Units or Refill Units and for the Grappler tool (storage for Fault Fiter Electronic Power Fuses or current-limiting fuses cannot be provided in these racks). A folding switch-operating handle, secured inside the switch-operating-hub pocket, is provided for each Mini-Rupter Switch. Terminal pads can accommodate a variety of cable-terminating devices for cable sizes through 1000 kc mil for switch and bus terminals, 4/0 maximum for fuse terminals. Each switch, fuse, and bus terminal is provided with a ground stud as is each ground pad.

All terminal pads can accommodate a variety of cable-terminating devices for cable sizes through 1000 kc mil for switch terminals, 4/0 maximum for fuse terminals. The cable-terminating devices must be equipped either with an offset spade-type compression terminal for bolting directly to the terminal pad or with a rod-type compression terminal for attachment to a connector of the type shown in Table 17 on page 21. For applications where additional height is desired for increased elevation of ungrounded parts above the mounting pad and to facilitate cable pulling and installation of cable-terminating devices, particularly where no cable pit is used, base spacers are available as listed in Table 4 on page 10.

While the interior of S&C Pad-Mounted Gear is protected from direct exposure to the elements, it is inherently designed for an outdoor environment and requires selection and application of cable-terminating devices accordingly. Terminations must incorporate adequate leakage distance between the exposed conductor and the stress-relief cone across a surface of nontracking material (or a surface rendered nontracking by properly taping with a suitable material).

Furthermore, to maintain the rated BIL, the following minimum clearances are required: 6 inches (152 mm) at 14.4 kV and 7½ inches (191 mm) at 25 kV from energized parts to electrical ground; 1 inch (25 mm) at 14.4 kV and 2¼ inches (57 mm) at 25 kV from energized parts to fiberglass-reinforced polyester barriers; ½-inch (13 mm) at 14.4 kV and 1¼ inches (32 mm) at 25 kV from terminator skirts to fiberglass-reinforced polyester barriers.

Exclusions

Three-phase units listed in Table 3 on pages 7 through 9 do not include the items listed in Table 4 on page 10 through 14, nor do they include the connector, fuse components, switch blades, or accessories listed in Table 5, Table 6, and Table 7 on page 15, or Table 14, Table 15 and Table 17 on page 21.

Specification Deviations

Features or modifications other than those listed in Table 4 on page 10 cannot be accommodated. Specifically, the following modifications or additions are not available except in custom-design gear or other standard models of S&C gear:

- Relocation of components (switches and fuses)
- Inclusion, in fuse compartments, of surge arresters or porcelain cable-terminating devices
- Separable insulated 200- or 600-ampere connectors
- Intermediate- or station-class surge arresters
- Mechanical interlocks

Certain minor departures from the optional features can be accommodated. For example, the user may use mounting provisions for different porcelain cable terminators in a switch compartment and bus compartment. Such deviations can be accommodated by a “minor modification.” Contact the nearest S&C Sales Office for availability.

Application Notes

For application information and a guide to the selection of appropriate ampere ratings and speeds of S&C SML Power Fuses, and types and TCC curve parameters of control modules for Fault Fiter Electronic Power Fuses, contact the nearest S&C Sales Office.

Switching with a Uni-Rupter Interrupter

Manual PMH Pad-Mounted Gear features fuses with Uni-Rupter Interrupters for single-pole live switching of single-phase or three-phase load circuits on distribution systems rated 14.4 kV or 25 kV.

Complete ratings and capabilities of S&C Power Fuses with Uni-Rupter Interrupters as applied in manual PMH Pad-Mounted Gear are shown in Table 1 on page 6. The Uni-Rupter Interrupter is also capable of carrying and interrupting load currents up to and including the emergency peak-load capabilities of the associated SML power fuses. In addition to the load-dropping capabilities shown, the Uni-Rupter Interrupter is capable of interrupting transformer magnetizing currents associated with the applicable loads as well as line-charging and cable-charging currents typical for distribution systems of these voltage ratings.

The duty-cycle fault-closing capabilities shown for S&C Power Fuses with Uni-Rupter Interrupters represent the fault-closing capabilities of the fuse with the Uni-Rupter Interrupter when the fuse is closed with a purposeful thrust without hesitation. Following the specified number of such closings (two or three), the Uni-Rupter Interrupter will remain operable and able to carry and interrupt rated current.

A Note on Single-Pole Switching

In single-pole switching of ungrounded-primary three-phase transformers or banks (or a single-phase transformer connected line to line), circuit connections or parameters may, in some cases, produce excessive overvoltages. In particular, for the following applications above 22 kV, single-pole switching by any means—including the Uni-Rupter Interrupter—should be performed only under the conditions stated in italics

- Switching unloaded or lightly loaded delta-connected or ungrounded-primary wye-wye connected three-phase transformers or banks (or line-to-line connected single-phase transformers), rated 150 kVA or less three-phase, or 50 kVA or less single-phase—or of any kVA rating when combined with unloaded cables or lines—where maximum system operating voltage exceeds 22 kV (*Single-pole switching should be performed only if each phase is carrying 5% load or more, or if the transformer or bank is temporarily grounded at the primary neutral during switching.*)
- Switching loaded or unloaded ungrounded-primary wye-delta connected three-phase transformers or banks—alone or combined with unloaded cables or lines—where maximum system operating voltage exceeds 22 kV (*Single-pole switching should be performed only if each phase is carrying 5% load or more and if the lighting-load phase is always switched open first (or switched closed last), or if the transformer or bank is temporarily grounded at the primary neutral during switching.*)

Recommended Voltage Ratings of Current-Limiting Fuses for Use in S&C Pad-Mounted Gear

In general, current-limiting fuses should have a maximum voltage rating equal to, but not greater than 140% of, the system line-to-line voltage because for most applications, the fuses can be exposed to full system line-to-line voltage in clearing faults. Although there may be economic or space-saving incentives for using current-limiting fuses with voltage ratings “appropriate for system line-to-ground voltage” (i.e., fuses with a voltage rating lower than line-to-line voltage but greater than or equal to maximum system line-to-ground voltage), S&C can recommend such use only in any of the following applications:

- Protection of single-phase transformers serving single-phase loads

- Protection of three-phase lateral circuits fed by a single-conductor shielded cable (provided each transformer on that lateral is individually fused so the current-limiting fuse serving the lateral will not be required to clear secondary faults)
- Protection of single-phase lateral circuits fed by a single-conductor shielded cable where the load is line-to-ground connected

Switching with a Mini-Rupter Switch

Manual PMH Pad-Mounted Gear features Mini-Rupter Switches for three-pole live switching of three-phase circuits.

Complete ratings for Mini-Rupter Switches as applied in manual PMH Pad-Mounted Gear are shown in Table 2 on page 6. In addition to the load-dropping ratings shown, a Mini-Rupter Switch is capable of interrupting transformer magnetizing currents associated with the applicable loads as well as line-charging and cable-charging currents typical for distribution systems of these voltage ratings.

For applications on systems rated higher than 7.2 kV and involving load current with high harmonic content (such as rectifier load currents), refer to the nearest S&C Sales Office. The two-time duty-cycle fault-closing ratings shown for Mini-Rupter Switches define the ability to close the Mini-Rupter Switch twice against a three-phase fault with asymmetrical current in at least one phase equal to the rated value, with the switch remaining operable and able to carry and interrupt rated current.

Warranty Qualifications

The standard warranty contained in the seller’s standard conditions of sale (as set forth in Price Sheet 150) does not apply to manual PMH Pad-Mounted Gear where fuse units, fuse unit end-fittings, holders, refill units, or switch blades of other than S&C manufacture are used in conjunction with S&C SML Mountings. Nor does it apply to manual PMH Pad-Mounted Gear where other than Fault Fiter Electronic Power Fuses, S&C Switch Blades, or the current-limiting fuses listed in Table 1 of S&C Information Bulletin 660-50 are used in conjunction with Fault Fiter Electronic Power Fuse mountings and S&C Holders designed therefor, or when current-limiting fuses are applied other than as set forth in the “Recommended Voltage Ratings of Current-Limiting Fuses for Use in S&C Pad-Mounted Gear” section.

Complete the following steps for a typical order of manual PMH Pad-Mounted Gear:

STEP 1. Select the three-phase pad-mounted gear.

- (a) Obtain the catalog number of the desired unit from Table 3 on pages 7 through 9.

Catalog Number:

- (b) Add suffix designations (to the catalog number above) to indicate the optional features desired, selected from Table 4 on pages 10 through 14.

Suffix: -

- (c) Obtain the catalog number of the connector, accessories, and touch-up kit components from Table 15, Table 16, and Table 17 on page 21.

Catalog Number: -

STEP 2. Select the fuse components and switch blades

- (a) **For SML-20 Power Fuses:** Obtain the catalog number of the end-fittings and the fuse units from Table 5 on page 15, taking care to match the voltage rating of the end fittings to the fuse units.

Catalog Number:

- (b) **For SML-4Z Power Fuses:** Obtain the catalog number of the holder and refill units from Table 6 on page 15, taking care to match the voltage rating of the holder to the refill units.

Catalog Number:

- (c) **For Fault Fiter Electronic Power Fuses:** Obtain the catalog number for the holders, the interrupting modules, and the control modules from Table 7 on page 15, taking care to match the voltage rating of the holders, interrupting modules, and the control modules.

Catalog Number:

- (d) **For switch blades:** Obtain the catalog number for the switch blades from Table 14 on page 21.

Catalog Number:

Example: The catalog number of a 14.4-kV manual Model PMH-9 with SML-20 Mountings, optional cable guides for switches and fuses, and 10-kV metal-oxide surge arresters at all switch terminals is:.

Catalog Number:

-

Ratings Tables

Table 1. Ratings and Capabilities for S&C Power Fuses With Uni-Rupter Interrupters

Fuse Type	Voltage, kV			Current, Amperes, RMS				
	Nom.	Max	BIL	Max	Interr. (Sym.)	Live Switching		
						Load Splitting (Parallel or Loop Switching)	Load Dropping	Duty-Cycle Fault-Closing RMS, Sym.
SML-20	14.4	17	95	200E or 200K	14 000	200	200	14 000 ●
	25	27	125	200E or 200K	12 500	200	200	12 500 ■
SML-4Z	14.4	17	95	200E	12 500	200	200	12 500 ●
	25	27	125	200E	12 500 ▲	200	200	12 500 ■
Fault Fiter fuse	14.4	17	95	200	14 000	200	200	14 000 ●
	25	29	125	200	12 500	200	200	12 500 ■

- Three-time duty-cycle fault-closing capability
- Two-time duty-cycle fault-closing capability

▲ Applicable to solidly ground-neutral systems only, with fuses connected by single-conductor, concentric-neutral-type cable to a transformer or transformers. Rating is 9,400 amperes, RMS, symmetrical for all other applications.

Table 2. Ratings for Mini-Rupter Switches

Voltage, kV				Current, Amperes					
Nom.	Max	BIL	Cont.	Live Switching		Three-Time Duty-Cycle Fault-Closing		Short-Circuit	
				Load-Splitting (Parallel or Loop Switching)	Load Dropping	Peak	RMS, Sym.	Peak Withstand, Peak	One-Second Short Time Withstand, RMS, Sym.
14.4	17.5	95	600	600	600	36 400	14 000	36 400	14 000
25	29	125	600	600	600	32 500	12 500	32 500	12 500

Table 3. Three-Phase Units (Including mountings with Uni-Rupter Interrupters—less fuse components^①)

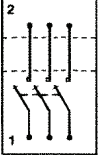
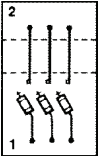
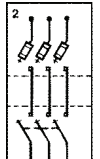
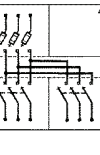
Model	Connection Diagram ^②	Fuse Type	Ratings ^③									Catalog Number	Net Wt., Lbs.	Page Reference for Dimensional Information
			kV			Amperes, RMS				Short-Circuit				
			Nom.	Max	BIL	Fuse with Uni-Rupter Interrupter		Mini-Rupter Switch		Amperes, RMS, Sym.	MVA 3-Phase Sym. at Rated Voltage			
						Max	Load Dropping	Cont.	Load Dropping					
PMH-3		—	14.4	17	95	—	—	600	600	14 000	350	55232R3	650	21
			25	29	125	—	—	600	600	12 500	540	55233R3	950	
PMH-4●		SML-20	14.4	17	95	200E■	200	—	—	14 000	350	55102R3	525	22
			25	27	125	200E■	200	—	—	12 500	540	55103R3	675	
		SML-4Z	14.4	17	95	200E	200	—	—	12 500	310	55302R3	525	
			25	27	125	200E	200	—	—	12 500▲	540▲	55303R3	675	
		Fault Fiter Fuse ^④	14.4	17	95	200	200	—	—	14 000	350	55502R3	525	
			25	29	125	200	200	—	—	12 500	540	55503R3	675	
PMH-5◆		SML-20	14.4	17	95	200E■	200	600	600	14 000	350	55112R3	825	23
			25	27	125	200E■	200	600	600	12 500	540	55113R3	1150	
		SML-4Z	14.4	17	95	200E	200	600	600	12 500	310	55312R3	825	
			25	27	125	200E	200	600	600	12 500▲	540▲	55313R3	1150	
		Fault Fiter Fuse ^④	14.4	17	95	200	200	600	600	14 000	350	55512R3	825	
			25	29	125	200	200	600	600	12 500	540	55513R3	1150	
PMH-6◆		SML-20	14.4	17	95	200E■	200	600	600	14 000	350	55122R4	1475	24
			25	27	125	200E■	200	600	600	12 500	540	55123R3	1975	
		SML-4Z	14.4	17	95	200E	200	600	600	12 500	310	55322R4	1475	
			25	27	125	200E	200	600	600	12 500▲	540▲	55323R3	1975	
		Fault Fiter Fuse ^④	14.4	17	95	200	200	600	600	14 000	350	55522R4	1475	
			25	29	125	200	200	600	600	12 500	540	55523R3	1975	

① Fuse components are to be ordered separately. Refer to Table 5, Table 6 and Table 7 on page 15, Table 8 on page 16, Table 9 on page 17, Table 10 on page 18, Table 11 and Table 12 on page 19, and Table 13 on page 20.

② Compartment numbers appear in corners of each diagram.

③ The short-circuit ratings expressed in amperes, RMS, asymmetrical are 1.6 times the symmetrical values listed. Fault-closing and/or momentary ratings of switches and bus, and fault-closing capabilities and interrupting ratings of fuses, equal or exceed these values. For complete live-switching (as well as momentary and one-second) ratings for Mini-Rupter Switches and complete live-switching capabilities of Uni-Rupter Interrupters as applied in manual PMH Pad-Mounted Gear, refer to Application Notes on page 3.

④ These models also accommodate selected current-limiting fuses in S&C Holders; refer to Table 1 of S&C Information Bulletin 660-50. Maximum voltage and maximum ampere ratings as listed in that table apply when current-limiting fuses are used. Consult appropriate current-limiting fuse manufacturer for complete fuse ratings.

● Available only when ultimate user is an electric utility.

■ SMU-20 Fuse Units are available in ratings through 200K amperes as well as 200E amperes.

▲ Applicable to solidly grounded-neutral systems only, with fuses connected by single-conductor, concentric-neutral-type cable to a transformer or transformers. Rating is 9400 amperes, RMS, symmetrical (405 MVA) for all other applications.

◆ Key interlocks (catalog number suffix “-C3” or “-C4”) are required for ultimate users other than electric utilities.

TABLE CONTINUED ►

Ordering Tables

Table 3. Three-Phase Units (Including mountings with Uni-Rupter Interrupters—less fuse components^①)—Continued

Model	Connection Diagram ^②	Fuse Type	Ratings ^③									Catalog Number	Net Wt., Lbs.	Page Reference for Dimensional Information
			kV			Amperes, RMS				Short-Circuit				
			Nom.	Max	BIL	Fuse with Uni-Rupter Interrupter		Mini-Rupter Switch		Amperes, RMS, Sym.	MVA 3-Phase Sym. at Rated Voltage			
						Max	Load Dropping	Cont.	Load Dropping					
PMH-7◆		SML-20	14.4	17	95	200E■	200	600	600	14 000	350	55132R4	1400	25
			25	27	125	200E■	200	600	600	12 500	540	55133R3	1875	
		SML-4Z	14.4	17	95	200E	200	600	600	12 500	310	55332R4	1400	
			25	27	125	200E	200	600	600	12 500▲	540▲	55333R3	1875	
		Fault Fiter Fuse ^④	14.4	17	95	200	200	600	600	14 000	350	55532R4	1400	
			25	29	125	200	200	600	600	12 500	540	55533R3	1875	
PMH-8●		SML-20	14.4	17	95	200E■	200	600	600	14 000	350	55142R4	1350	26
			25	27	125	200E■	200	600	600	12 500	540	55143R3	1900	
		SML-4Z	14.4	17	95	200E	200	600	600	12 500	310	55342R4	1350	
			25	27	125	200E	200	600	600	12 500▲	540▲	55343R3	1900	
		Fault Fiter Fuse ^④	14.4	17	95	200	200	600	600	14 000	350	55542R4	1350	
			25	29	125	200	200	600	600	12 500	540	55543R3	1900	
PMH-9◆		SML-20	14.4	17	95	200E■	200	600	600	14 000	350	55152R4	1550	27
			25	27	125	200E■	200	600	600	12 500	540	55153R3	2050	
		SML-4Z	14.4	17	95	200E	200	600	600	12 500	310	55352R4	1550	
			25	27	125	200E	200	600	600	12 500▲	540▲	55353R3	2050	
		Fault Fiter Fuse ^④	14.4	17	95	200	200	600	600	14 000	350	55552R4	1550	
			25	29	125	200	200	600	600	12 500	540	55553R3	2050	
PMH-10		—	14.4	17	95	—	—	600	600	14 000	350	55242R4	1725	28
			25	29	125	—	—	600	600	12 500	540	55243R3	2275	

① Fuse components are to be ordered separately. Refer to Table 5, Table 6 on page 15 and Table 7 on page 15, Table 8 on page 16, Table 9 on page 17, Table 10 on page 18, Table 11 and Table 12 on page 19, and Table 13 on page 20.

② Compartment numbers appear in corners of each diagram.

③ The short-circuit ratings expressed in amperes, RMS, asymmetrical are 1.6 times the symmetrical values listed. Fault-closing and/or momentary ratings of switches and bus, and fault-closing capabilities and interrupting ratings of fuses, equal or exceed these values. For complete live-switching (as well as momentary and one-second) ratings for Mini-Rupter Switches and complete live-switching capabilities of Uni-Rupter Interrupters as applied in manual PMH Pad-Mounted Gear, refer to Application Notes on page 3.

④ These models also accommodate selected current-limiting fuses in S&C Holders; refer to Table 1 in S&C Information Bulletin 660-50. Maximum voltage and maximum ampere ratings as listed in that table apply when current-limiting fuses are used. Consult appropriate current-limiting fuse manufacturer for complete fuse ratings.

● Available only when ultimate user is an electric utility.

■ SMU-20 Fuse Units are available in ratings through 200K amperes as well as 200E amperes.

▲ Applicable to solidly grounded-neutral systems only, with fuses connected by single-conductor, concentric-neutral-type cable to a transformer or transformers. Rating is 9400 amperes, RMS, symmetrical (405 MVA) for all other applications.

◆ Key interlocks (catalog number suffix “-C3” or “-C4”) are required for ultimate users other than electric utilities.

TABLE CONTINUED ►

Table 3. Three-Phase Units (Including mountings with Uni-Rupter Interrupters—less fuse components^①)—Continued

Model	Connection Diagram ^②	Fuse Type	Ratings ^③									Catalog Number	Net Wt., Lbs.	Page Reference for Dimensional Information
			kV			Amperes, RMS				Short-Circuit				
			Nom.	Max	BIL	Fuse with Uni-Rupter Interrupter		Mini-Rupter Switch		Amperes, RMS, Sym.	MVA 3-Phase Sym. at Rated Voltage			
			Max	Load Dropping	Cont.	Load Dropping								
PMH-11◆		SML-20	14.4	17	95	200E■	200	600	600	14 000	350	55162R4	1625	29
			25	27	125	200E■	200	600	600	12 500	540	55163R3	2175	
		SML-4Z	14.4	17	95	200E	200	600	600	12 500	310	55362R4	1625	
			25	27	125	200E	200	600	600	12 500▲	540▲	55363R3	2175	
		Fault Fiter Fuse ^④	14.4	17	95	200	200	600	600	14 000	350	55562R4	1625	
			25	29	125	200	200	600	600	12 500	540	55563R3	2175	
PMH-12◆		SML-20	14.4	17	95	200E■	200	600	600	14 000	350	55172R4	1450	30
			25	27	125	200E■	200	600	600	12 500	540	55173R3	1950	
		SML-4Z	14.4	17	95	200E	200	600	600	12 500	310	55372R4	1450	
			25	27	125	200E	200	600	600	12 500▲	540▲	55373R3	1950	
		Fault Fiter Fuse ^④	14.4	17	95	200	200	600	600	14 000	350	55572R4	1450	
			25	29	125	200	200	600	600	12 500	540	55573R3	1950	
PMH-13		—	14.4	17	95	—	—	600	600	14 000	350	55252R4	1525	31
			25	29	125	—	—	600	600	12 500	540	55253R3	2125	
PMH-19◆		SML-20	14.4	17	95	200E■	200	600	600	14 000	350	55212R4	1625	32
		SML-4Z	14.4	17	95	200E	200	600	600	12 500	310	55412R4	1625	
		Fault Fiter Fuse ^④	14.4	17	95	200	200	600	600	14 000	350	55612R4	1625	

① Fuse components are to be ordered separately. Refer to Table 5, Table 6 and Table 7 on page 15, Table 8 on page 16, Table 9 on page 17, Table 10 on page 18, Table 11 and Table 12 on page 19, and Table 13 on page 20.

② Compartment numbers appear in corners of each diagram.

③ The short-circuit ratings expressed in amperes, RMS, asymmetrical are 1.6 times the symmetrical values listed. Fault-closing and/or momentary ratings of switches and bus, and fault-closing capabilities and interrupting ratings of fuses, equal or exceed these values. For complete live-switching (as well as momentary and one-second) ratings for Mini-Rupter Switches and complete live-switching capabilities of Uni-Rupter Interrupters as applied in manual PMH Pad-Mounted Gear, refer to Application Notes on page 3.

④ These models also accommodate selected current-limiting fuses in S&C Holders; refer to Table 1 of S&C Information Bulletin 660-50. Maximum voltage and maximum ampere ratings as listed in that table apply when current-limiting fuses are used. Consult appropriate current-limiting fuse manufacturer for complete fuse ratings.

● Available only when ultimate user is an electric utility.

■ SMU-20 Fuse Units are available in ratings through 200K amperes as well as 200E amperes.

▲ Applicable to solidly grounded-neutral systems only, with fuses connected by single-conductor, concentric-neutral-type cable to a transformer or transformers. Rating is 9400 amperes, RMS, symmetrical (405 MVA) for all other applications.

◆ Key interlocks (catalog number suffix “-C3” or “-C4”) are required for ultimate users other than electric utilities.

Ordering Tables

Table 4. Optional Features

Item		Suffix to be Added to Pad-Mounted Gear Catalog Number	Applicable to Models
Light gray outdoor Ultradur II Outdoor Finish instead of olive green		-A2	All models
Equipment green Ultradur II Outdoor Finish (Toronto standard) instead of olive green		-A3	All models
Seafoam green Ultradur II Outdoor Finish instead of olive green		-A4	All models
Special color Ultradur II Outdoor Finish instead of olive green		-A5	All models
Stainless steel enclosure ^①	With olive green outdoor Ultradur II Outdoor Finish	-A10	All models
	With light gray outdoor Ultradur II Outdoor Finish	-A12	All models
	With special color outdoor Ultradur II Outdoor Finish	-A15	All models
Hexhead actuator for use in lieu of pentahead actuator on all Penta-Latch Mechanisms	For use except when catalog number suffix "-F2" is specified	-B1●■	All models
	For use when catalog number suffix "-F2" is also specified	-B2▲■	All models except PMH-4
Copper bus ^② and copper switch terminals, fuse connector adapters, and bus terminals		-B5	All models
Reinforced bus	Used with standard aluminum bus	-B6	15-kV models of PMH-6, -7, -8, -9, -10, -11, 12, -13
	Used with optional copper bus	-B7	
Key interlocks to prevent paralleling of switches in compartments 1 and 2 ^③		-C1	PMH-6, -9, -10, -11, -13, -19
Key interlocks to prevent opening fuse-compartment doors unless all switches (series tap switch only in PMH-19) are locked open ^③		-C3◆	PMH-5, -6, -7, -9, -11, -12, -19
Key interlocks. Combines functions of options "-C1" and "-C3" listed above ^③		-C4◆	PMH-6, -9, -11, -19
Fuse Storage feature for three spare fuse assemblies per compartment ^④	Located in compartment 1	-E1	PMH-5, -6, -7, -8, -9, -11, -19
	Located in compartment 2	-E2	PMH-6, -7, -9, -11, -12, -19
	Located in compartments 1 and 2	-E3	PMH-6, -7, -9, -11, -19

① When this optional feature is specified, the entire exterior of the enclosure is fabricated from 11-gauge Type 304 stainless steel. When specifying optional hexhead actuators, provisions for fault indicators with viewing windows in doors, or base spacer, specify the correct suffix for use in gear with a stainless steel enclosure.

② Copper bus measures ¼-inch (6 mm) by 2 inches (51mm).

③ When specifying, please furnish name of ultimate user, station, and location of gear.

④ Fuse assemblies (fuse holders or fuse units with end fittings) are not included. For units equipped with Fault Fiter Electronic Power Fuse mountings, two spare Fault Fiter fuse interrupting modules, one spare

Fault Fiter Electronic Power Fuse holder, or one spare current-limiting fuse holder can be accommodated in each compartment.

● Specify catalog number suffix "-B11" for gear with stainless steel enclosure.

■ Not available if UL listing (catalog number suffix "-X") is specified.

▲ Specify catalog number suffix "-B12" for gear with stainless steel enclosure.

◆ Must be specified if end user is not an electric utility and/or if Canadian Standards Association listing (catalog number suffix "-Z") is specified.

TABLE CONTINUED ►

Table 4. Optional Features—Continued

Item		Suffix to be Added to Pad-Mounted Gear Catalog Number	Applicable to Models
Mounting provisions for a fault indicator in each switch compartment (except series tap switch in PMH-19) ^⑤	Without viewing window in door	-F1	All models except PMH-4
	With viewing window in door	-F2▼□	All models except PMH-4
Inner barrier panels—a panel inside the enclosure door for each compartment, secured by recessed pentahead bolt(s) ^{⑥⑦}		-G7□	All models
Copper ground stud for each switch, fuse, or bus terminal and ground pad ^⑧	In fuse compartments ^⑨	-H2	All models except PMH-3, -10, -13
	In switch and bus compartments	-J2	All models except PMH-4

⑤ Accommodates three-phase indicator with single-phase sensors.

⑥ Where the National Electrical Safety Code (ANSI Standard C2) applies, this optional feature may be included to meet the requirements of Section 381G.

⑦ Meets RUS's requirements for "dead-front."

⑧ Diameters of copper ground studs are as follows:

Ground Stud	Diameter, in inches (mm)
Switch	½ (13)
Fuse	7/16 (11)
Bus Terminal	7/16 (11)
Ground Pad	7/16 (11)

⑨ Including bus-compartment terminals in Model PMH-4.

▼ Specify catalog number suffix "-F12" for gear with stainless steel enclosure.

□ Not available if Canadian Standards Association listing (catalog number suffix "-Z") is specified.

TABLE CONTINUED ►

Table 4. Optional Features—Continued

Item			Suffix to be Added to Pad-Mounted Gear Catalog Number	Applicable to Models
Base spacer, compartmented to match enclosure, increases cable-termination height	Carbon steel	6 inches (152 mm)	-K1	All models
		12 inches (305 mm)	-K2	All models
		18 inches (457 mm)	-K3	All models
		24 inches (610 mm)	-K4	All models
	Stainless steel	6 inches (152 mm)	-K11	All models
		12 inches (305 mm)	-K12	All models
		18 inches (457 mm)	-K13	All models
		24 inches (610 mm)	-K14	All models
Base spacer, noncompartmented, increases cable-termination height	Carbon steel	6 inches (152 mm)	-K7	All models
		12 inches (305 mm)	-K8	All models
		18 inches (457 mm)	-K9	All models
		24 inches (610 mm)	-K10	All models
	Stainless steel	6 inches (152 mm)	-K17	All models
		12 inches (305 mm)	-K18	All models
		18 inches (457 mm)	-K19	All models
		24 inches (610 mm)	-K20	All models

TABLE CONTINUED ►

Table 4. Optional Features—Continued

Item		Suffix to be Added to Pad-Mounted Gear Catalog Number	Applicable to Models
International crating ^⑩		-L71	All models
Switch- and bus-terminal adapters—for connection of two cables (through 750 kc mil) per terminal ^{⑪⑫}		-M1	All models
Cable guides, one at each terminal ^{⑪⑬}	In switch and bus compartments. For conductor sizes No. 2 through 1000 kc mil	-M2	All models
	In fuse compartments. For conductor sizes No. 2 through 4/0	-M3	PMH-4, -5, -6, -11, -19 PMH-7, -8, -9 PMH-12
Polymer-housed metal-oxide surge arresters ^⑭ , base-mounted, at switch terminals and bus terminals in compartments 1 and 2 (removed for shipment)	9 kV	-N6△	All models
	10 kV	-N7△	All models
	12 kV	-N8	All models
	15 kV	-N9	All models
	18 kV	-N10◇	All models except PMH-19
Metal-oxide surge arresters, ^⑮ base-mounted, at switch terminals and bus terminals in compartments 1 and 2 (removed for shipment)	3 kV	-N11▽	All models
	6 kV	-N12▽	All models

^⑩ Wood products used in the packaging are either hardwood or certified by the wood supplier as being “heat treated (kiln dried) to a core temperature of 133°F (56°C) for a minimum of 30 minutes.”

^⑪ When catalog number suffix “-M1” or “-M2” is specified, cable-termination options (catalog number suffix “-U2” and “-U3”) cannot be accommodated. In addition, when catalog number suffix “-M1” and “-M2” are both specified, only one cable guide is provided at each switch terminal.

^⑫ Space limitations prevent use of these adapters where surge arresters are to be installed

^⑬ These devices extend below the base of the unit. Provide a cable pit or specify a base spacer that provides a 12-inch (305 mm) or greater increase in cable-termination height.

^⑭ Surge arresters are base-mounted only (without isolators).

△ Not applicable to 25-kV models.

◇ Not applicable to 14.4-kV models.

▽ A supplemental label is provided for catalog number suffixes “-N11” and “-N12” indicating the voltage rating of the surge arresters furnished.

TABLE CONTINUED ►

Ordering Tables

Table 4. Optional Features—Continued

Item		Suffix to be Added to Pad-Mounted Gear Catalog Number	Applicable to Models
Mounting provisions for base-mounted surge arresters ^⑮ , at switch terminals and bus terminals in compartments 1 and 2	9 kV, 10 kV, or 9/10 kV	-P1△	All models
	12 kV	-P3	All models
	15 kV	-P4	All models
	18 kV	-P5◇	All models except PMH-19
Mounting provisions for porcelain cable terminators for single-conductor UD cable, at all cable-connected switch terminals and bus terminals	G&W PSC for No. 6 through 2/0⓪, or G&W PAT for No. 4 through 250 kc mil copper or aluminum cable	-U2	All models
	G&W PAT for 3/0 through 750 kc mil copper or 500 kc mil aluminum cable⓪	-U3	All models
UL listing. Includes “UL listed” symbol on ratings label and nameplate		-X■▲	All 14.4 kV models
Canadian Standards Association listing. Includes viewing window with tamper-resistant cover in switch compartment door(s), and hazard-alerting labels and nameplate per CSA specification		-Z◀◀⓪■	PMH-3, -5, -7, -12
			PMH-6, -9
			PMH-11, -13, -19
			PMH-10

⑮ These provisions accommodate Ohio Brass Type PDV (metal oxide), McGraw-Edison Type AZL19C (metal oxide), General Electric Tranquell® (metal oxide), or McGraw-Edison Type ES (silicon carbide) distribution-class surge arresters. Surge arresters must be base-mounted only (without isolators).

⓪ These devices extend below the base of the unit. Provide a cable pit or specify a base spacer.

△ Not applicable to 25-kV models.

◇ Not applicable to 14.4-kV models.

■ UL listing (catalog number suffix“-X”) cannot be furnished if Canadian Standards Association listing (catalog number suffix“-Z”) is specified and vice versa.

▲ Not available if hexhead actuator for use in lieu of pentahead actuator on all Penta-Latch Mechanisms (catalog number suffix“-B1,”“-B2,”“-B11,” or“-B12”) is specified.

◀ Key interlocks (catalog number suffix“-C3” or“-C4”) must be specified on gear with fuse compartment(s).

◁ Not available if mounting provisions for fault indicator with viewing window in switch compartment door(s) (catalog number suffix“-F2” or“-F12”) is specified.

⓪ Not available if inner barrier panels (catalog number suffix“-G7”) is specified.

Table 5. SML-20 Power Fuse Components

Fuse-Unit End Fittings	
Item	Catalog Number
End-fittings (including silencer), for use with SMU-20 Fuse Units	3097
SMU-20® Fuse Units ^①	
14.4 kV Nominal, 17 kV Max	25 kV Nominal, 27 kV Max
For a complete listing of available ampere ratings, speeds, and catalog numbers, refer to Table 8 on page 16 and Table 9 on page 17.	

① These fuse units are usable in SM-20, SMD-20, SML-20, and SME-20 Mountings.

Table 6. SML-4Z Power Fuse Components

Holders				
Item	Rating			Catalog Number
	kV		Amperes, Max	
	Nom.	Max		
Holder (including silencer), for use with SM-4 Refill Units	14.4	17	200E	92352
	25	27	200E	92353
SM-4® Refill Units ^①				
14.4 kV Nominal, 17 kV Max		25 kV Nominal, 27 kV Max		
For a complete listing of available ampere ratings, speeds, and catalog numbers, refer to Table 10 on page 18.				

① These fuse units are usable in SM-4, SM-4Z, SML-4Z, and SME-4Z Mountings.

Table 7. Fault Fiter Electronic Power Fuse Components

Holders				
Item	Rating			Catalog Number
	kV		Amperes, Cont.	
	Nom.	Max		
Holder, for use with Fault Fiter Electronic Power Fuses	13.8	17	400	99412R1
	25	29	200	99413R1
Interrupting Modules ^①				
Item	Rating			Catalog Number
	kV		Amperes, Cont.	
	Nom.	Max		
Interrupting module, for use with Fault Fiter Electronic Power Fuses	13.8	17	600	802600R2
	25	29	600	803600R2
Control Modules ^①				
For a complete listing of available types, TCC curve parameters, and catalog numbers, refer to Table 11 and Table 12 on page 19, and Table 13 on page 20.				

① Interrupting modules and control modules rated 600 amperes continuous are also applicable for use in mountings rated 200 or 400 amperes continuous.

Ordering Tables

Table 8. SMU-20® Fuse Units (For use in SM-20 or SML-20 Mountings)①

14.4 kV Nominal, 17 kV Max					
"K" Ratings			"E" Ratings		
Rating, Amperes ↓	Catalog Number	Rating, Amperes ↓	Catalog Number		
Speed →	S&C "K" TCC 165-2	Speed →	S&C Std. TCC 115-2		
		1	702001		
		Speed →	S&C Std. TCC 153-2	S&C Slow TCC 119-2	S&C Very Slow TCC 176-2
3K	702003				
6K	702006	5E	612005		
8K	702008	7E	612007		
10K	702010	10E	612010		
12K	702012	13E	612013		
15K	702015	15E	612015	712015	
20K	702020	20E	612020	712020	
25K	702025	25E	612025	712025	
30K	702030	30E	612030	712030	
40K	702040	40E	612040	712040	
50K	702050	50E	612050	712050	602050
65K	702065	65E	612065	712065	602065
80K	702080	80E	612080	712080	602080
100K	702100	100E	612100	712100	602100
140K	702140	125E	612125	712125	602125
200K	702200	150E	612150	712150	602150
		175E	612175	712175	602175
		200E	612200	712200	602200

① These fuse units are equally suitable for use in SMD-20 Outdoor Distribution Mountings and for use with SME-20 Fuse Unit End-Fittings listed in S&C Specification Bulletin 665-31, "S&C Manual PME Pad-Mounted Gear" and in S&C Specification Bulletin 666-31, "S&C Remote Supervisory PME Pad-Mounted Gear."

Table 9. SMU-20® Fuse Units (For use in SM-20 or SML-20 Mountings)①

25 kV Nominal, 27 kV Max②					
“K” Ratings			“E” Ratings		
Rating, Amperes ↓	Catalog Number	Rating, Amperes ↓	Catalog Number		
Speed →	S&C “K” TCC 165-2	Speed →	S&C Std. TCC 115-2		
		1	703001		
		Speed →	S&C Std. TCC 153-2	S&C Slow TCC 119-2	S&C Very Slow TCC 176-2
3K	703003				
6K	703006	5E	613005		
8K	703008	7E	613007		
10K	703010	10E	613010		
12K	703012	13E	613013		
15K	703015	15E	613015	713015	
20K	703020	20E	613020	713020	
25K	703025	25E	613025	713025	
30K	703030	30E	613030	713030	
40K	703040	40E	613040	713040	
50K	703050	50E	613050	713050	603050
65K	703065	65E	613065	713065	603065
80K	703080	80E	613080	713080	603080
100K	703100	100E	613100	713100	603100
140K	703140	125E	613125	713125	603125
200K	703200	150E	613150	713150	603150
		175E	613175	713175	603175
		200E	613200	713200	603200

① These fuse units are equally suitable for use in SMD-20 Outdoor Distribution Mountings and for use with SME-20 Fuse Unit End-Fittings listed in S&C Specification Bulletin 665-31, “S&C Manual PME Pad-Mounted Gear” and in S&C Specification Bulletin 666-31, “S&C Remote Supervisory PME Pad-Mounted Gear.”

② Also suitable for protection of single-phase-to-neutral circuits (lines or transformers) on 20/34.5 GrY-kV systems.

Ordering Tables

Table 10. SM-4® Refill Units (For use in SM-4 and SML-4 Holders)①

Rating, Amperes ↓	14.4 kV Nominal, 17 kV Max②			25 kV Nominal, 27 kV Max	
	Catalog Number			Catalog Number	
Speed →	S&C Std. TCC 115-4			S&C Std. TCC 115-4	
1	122001R4			123001R4	
2	122002R4			123002R4	
Speed →	S&C Std. TCC 153-4	S&C Slow TCC 119-4	S&C Coord. TCC 179-4	S&C Std. TCC 153-4	S&C Slow TCC 119-4
3E	122005R4			123005R4	
5E	122007R4			123007R4	
7E	122010R4			123010R4	
10E	122015R4			123015R4	
13E	122020R4			123020R4	
15E	122025R4	252025R4		123025R4	253025R4
20E	122030R4	252030R4		123030R4	253030R4
25E	122040R4	252040R4		123040R4	253040R4
30E	122050R4	252050R4		123050R4	253050R4
40E	122060R4	252060R4		123060R4	253060R4
50E	122075R4	252075R4		123075R4	253075R4
65E	122100R4	252100R4		123100R4	253100R4
80E	122125R4	252125R4		123125R4	253125R4
100E	122150R4	252150R4		123150R4	253150R4
125E	122200R4	252200R4		123200R4	253200R4
150E	122250R4	252250R4		123250R4	253250R4
175E	122275R4	252275R4		123275R4	253275R4
200E	122300R4	252300R4		123300R4	253300R4
210E			382210R4●		

① These refill units are also suitable for use with SME-4Z Holders listed in S&C Specification Bulletin 665-31, "S&C Manual PME Pad-Mounted Gear" and in S&C Specification Bulletin 666-31, "S&C Remote Supervisory PME Pad-Mounted Gear."

② Rated 14.4 kV nominal, for use in SM-4 Holders rated 14.4 kV when applied in listed mountings rated 13.8 kV or in discontinued mountings rated 14.4 kV.

● This S&C Coordinating Speed refill unit should be applied where the maximum continuous load current does not exceed 200 amperes and where all fault currents below 1000 amperes will be cleared by another fuse.

Table 11. Fault Fiter Fuse Control Modules—Underground Subloop^① Type (TCC No. 422-7)

Continuous Current, Amperes, Max ^②	TCC Curve Parameters				Catalog Number
	Minimum Pickup, Amperes, RMS	Short-Time Pickup, Amperes, RMS	Short-Time Delay Band	Instantaneous Pickup, Amperes, RMS	
600	400	1300	2	3000	7020-C40P130S2T3
	500	1300	1	3000	7020-C50P130S1T3

① This control module is applicable for protection of 15-kV and 25-kV class underground distribution subloops having the following parameters: maximum available fault current—14,000 amperes, RMS, symmetrical at 15 kV, 12,500 amperes, RMS, symmetrical at 25 kV; maximum rated transformer kVA connected for residential circuits—1200 kVA single-phase, 3600 kVA three-phase at 15 kV, 2400 kVA single-phase, 7200 kVA three-phase at 25 kV; with no capacitor banks

or current-limiting fuses on the load side of the Fault Fiter fuse. If the maximum rated transformer kVA connected is greater than the values listed above, or if the application involves protection of circuits serving industrial, commercial, or institutional loads, contact the nearest S&C Sales Office.

② Control modules rated 600 amperes continuous are also applicable for use in mountings rated 200 amperes or 400 amperes continuous.

Table 12. Fault Fiter Fuse Control Modules—Inverse Curve Type (TCC No. 410-7)

Continuous Current, Amperes, Max ^①	Minimum Pickup, Amperes, RMS	Catalog Number
600	400	814040
	500	814050
	600	814060
	700	814070
	800	814080
	1000	814100
	1250	814125
	1500	814150

① Control modules rated 600 amperes continuous are also applicable for use in mountings rated 200 amperes or 400 amperes continuous.

Ordering Tables

Table 13. Fault Fiter Fuse Control Modules—Time-Delayed Compound-Curve Type (TCC No. 421-7)

Continuous Current, Amperes, Max ^①	TCC Curve Parameters				Catalog Number
	Minimum Pickup, Amperes, RMS	Short-Time Delay Band	High-Current Pickup, Amperes, RMS	High-Current Delay Band Time Delay, ms	
600	400	1	3000	8	7010-C40S1T3D8
			6000	8	7010-C40S1T6D8
		2	3000	8	7010-C40S2T3D8
			6000	8	7010-C40S2T6D8
		3	3000	8	7010-C40S3T3D8
			6000	8	7010-C40S3T6D8
		4	3000	8	7010-C40S4T3D8
			6000	8	7010-C40S4T6D8
	600	1	3000	8	7010-C60S1T3D8
			6000	8	7010-C60S1T6D8
		2	3000	8	7010-C60S2T3D8
			6000	8	7010-C60S2T6D8
		3	3000	8	7010-C60S3T3D8
			6000	8	7010-C60S3T6D8
		4	3000	8	7010-C60S4T3D8
			6000	8	7010-C60S4T6D8
	800	1	3000	8	7010-C80S1T3D8
			6000	8	7010-C80S1T6D8
		2	3000	8	7010-C80S2T3D8
			6000	8	7010-C80S2T6D8
		3	3000	8	7010-C80S3T3D8
			6000	8	7010-C80S3T6D8
		4	3000	8	7010-C80S4T3D8
			6000	8	7010-C80S4T6D8
	1100	1	3000	8	7010-C110S1T3D8
			6000	8	7010-C110S1T6D8
		2	3000	8	7010-C110S2T3D8
			6000	8	7010-C110S2T6D8
3		3000	8	7010-C110S3T3D8	
		6000	8	7010-C110S3T6D8	
4		3000	8	7010-C110S4T3D8	
		6000	8	7010-C110S4T6D8	

^① Control modules rated 600 amperes continuous are also applicable for use in mountings rated 200 amperes or 400 amperes continuous.

Table 14. Switch Blades^①

Item	Rating			Catalog Number
	kV		Amperes, Cont.	
	Nom.	Max		
Switch blade, for use in lieu of SMU-20 Fuse Unit in SML-20 Mounting	14.4	17	200	5432
	25	27	200	5433
Switch blade, for use in lieu of SML-4Z Holder in SML-4 Mounting	14.4	17	200	5442
	25	27	200	5443
Switch blade, for use in lieu of Fault Fiter fuse holder in Fault Fiter fuse mounting	14.4	17	400	3222
	25	29	200	3223R1

① When switch blades are used in lieu of fuses, the Uni-Rupter Interrupter associated with these switches can carry and interrupt load currents up to and including the emergency peak-load capabilities of the SML power fuses, or up to 400 amperes at 14.4 kV and 200 amperes at 25 kV for Fault Fiter Electronic Power Fuses. Furthermore, the switches

with a Uni-Rupter Interrupter have fault-closing ratings equal to those of S&C Power Fuses with Uni-Rupter Interrupters (refer to Application Notes on page 3). The momentary and one-second ratings of the switches equal the short-circuit ratings of the pad-mounted gear.

Table 15. Accessories

Item	Catalog Number	
Grounding jumpers, set of three, with eye-type clamps for installation with a standard shotgun clamp stick	3-foot (914-mm) cable length 4210	
Shotgun clamp sticks for use with separable connectors and voltage testers	77½ inches (1969 mm) 9933-150	
	101½ inches (2578 mm) 9933-151	
Storage bag, heavy canvas	For grounding jumpers 9933-149	
	For shotgun clamp stick	78 inches (1981 mm) 9933-152
		102 inches (2591 mm) 9933-153
Voltage tester with audio and visual signals, includes voltage tester, batteries, adapter for shotgun clamp sticks, and storage case ^①	9931-072	
Pentahead socket, for ½-inch drive	9931-074	

① For ultimate users other than electric utilities, also specify a shotgun clamp stick of the appropriate length.

Table 16. Touch-Up Kit Components—Aerosol Coatings in 12-Ounce Cans

Item	Catalog Number
S&C Light Gray Outdoor Finish	9999-080
S&C Olive Green (Munsell 7GY3.29/1.5) Outdoor Finish	9999-058
S&C Red-Oxide Primer	9999-061

Table 17. Connector

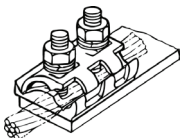
Illustration	Description	Accommodating Connector	Catalog Number
	Bronze body, tin-plated, two galvanized steel bolts, two Belleville washers	No. 2 solid (33.6 mm ²) through 500 kc mil (253 mm ²) stranded copper or aluminum	4745

Ordering Tables

Model PMH-3

14.4 kV and 25 kV Nominal

Dimensions in inches (mm)

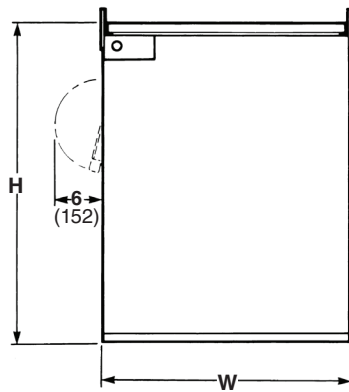

FRONT VIEW

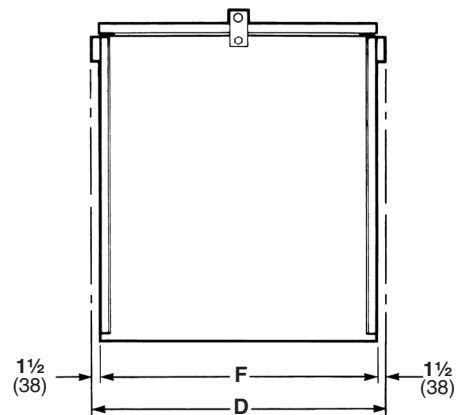

SIDE VIEW

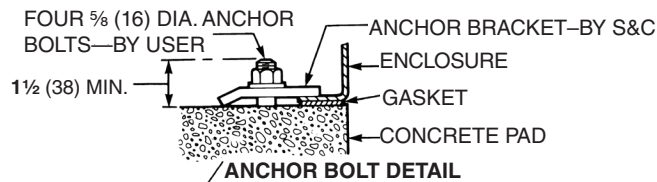

ANCHOR BOLT DETAIL

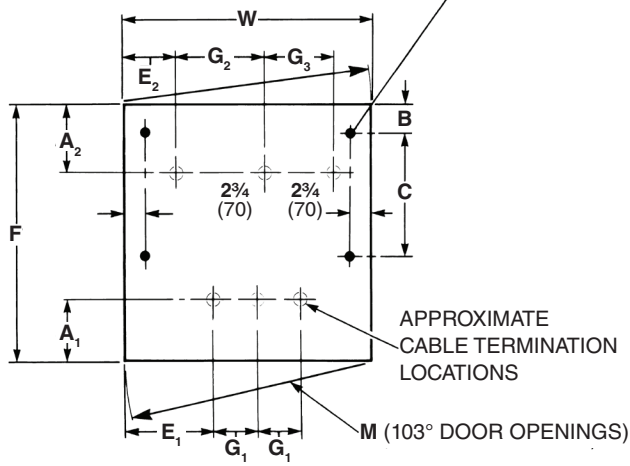

ANCHOR BOLT PLAN

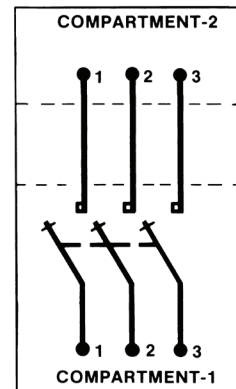

CONNECTION DIAGRAM

kV, Nominal	A ₁ ●	A ₂ ●	B	C	D	E ₁	E ₂	F	G ₁	G ₂	G ₃	H	M	W
14.4	9 ⁷ / ₈ (251)	11 ¹ / ₈ (283)	5 ¹ / ₈ (130)	17 (432)	40 ³ / ₄ (1035)	12 ⁷ / ₈ (327)	7 ¹ / ₂ (191)	37 ³ / ₄ (959)	6 (152)	9 ³ / ₄ (248)	9 ³ / ₄ (248)	44 (1118)	34 (864)	34 ⁷ / ₈ (886)
25	14 ¹ / ₈ (359)	15 ¹ / ₄ (387)	7 ¹ / ₈ (181)	42 ¹ / ₂ (1080)	59 ³ / ₄ (1518)	13 ³ / ₄ (349)	9 ⁵ / ₈ (244)	56 ³ / ₄ (1441)	7 ¹ / ₂ (191)	10 (254)	12 ¹ / ₂ (318)	55 (1397)	42 ¹ / ₂ (1080)	43 (1092)

● When catalog number suffix “-M1,” “-U2,” or “-U3” is specified, cable-termination locations will be slightly affected. Consult the nearest S&C Sales Office for details.

Model PMH-4
14.4 kV and 25 kV Nominal

Dimensions in inches (mm)

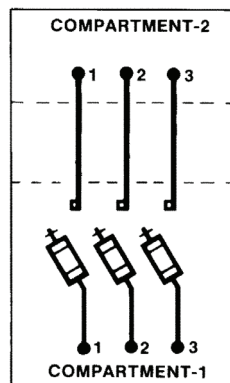
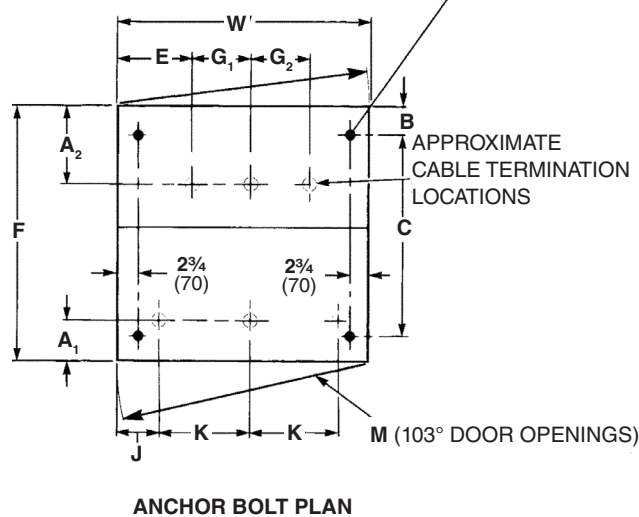
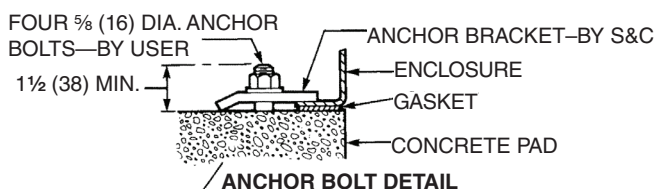
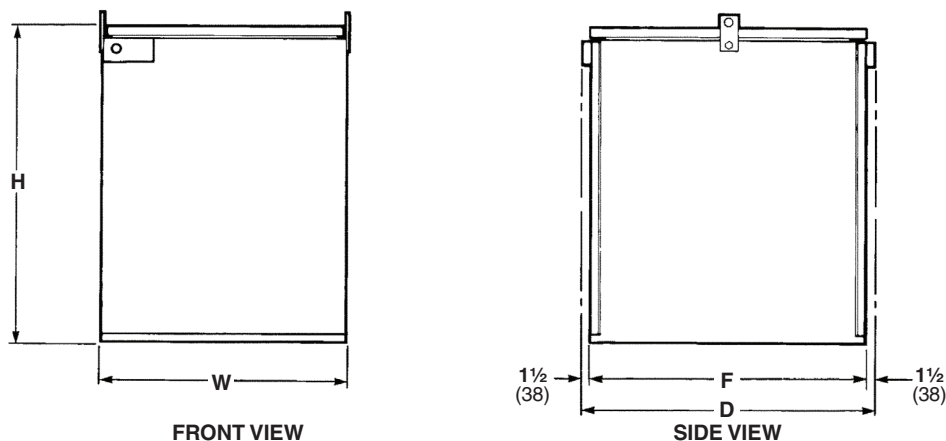

kV, Nominal	A ₁	A ₂ ●	B	C	D	E	F	G ₁	G ₂	H	J	K	M	W
14.4	7 (178)	11 1/8 (283)	5 1/8 (130)	27 1/2 (699)	40 3/4 (1035)	7 7/8 (200)	37 3/4 (959)	9 3/4 (248)	9 3/4 (248)	44 (1118)	10 1/2 (267)	9 3/4 (248)	34 (864)	34 7/8 (886)
25	11 1/4 (286)	15 1/4 (387)	7 1/8 (181)	42 1/2 (1080)	59 3/4 (1518)	9 9/8 (244)	56 3/4 (1441)	10 (254)	12 1/2 (318)	55 (1397)	11 1/2 (292)	12 1/2 (318)	42 1/2 (1080)	43 (1092)

● When catalog number suffix "-M1," "-U2," or "-U3" is specified, cable-termination locations will be slightly affected. Consult the nearest S&C Sales Office for details.

Ordering Tables

Model PMH-5

14.4 kV and 25 kV Nominal

Dimensions in inches (mm)

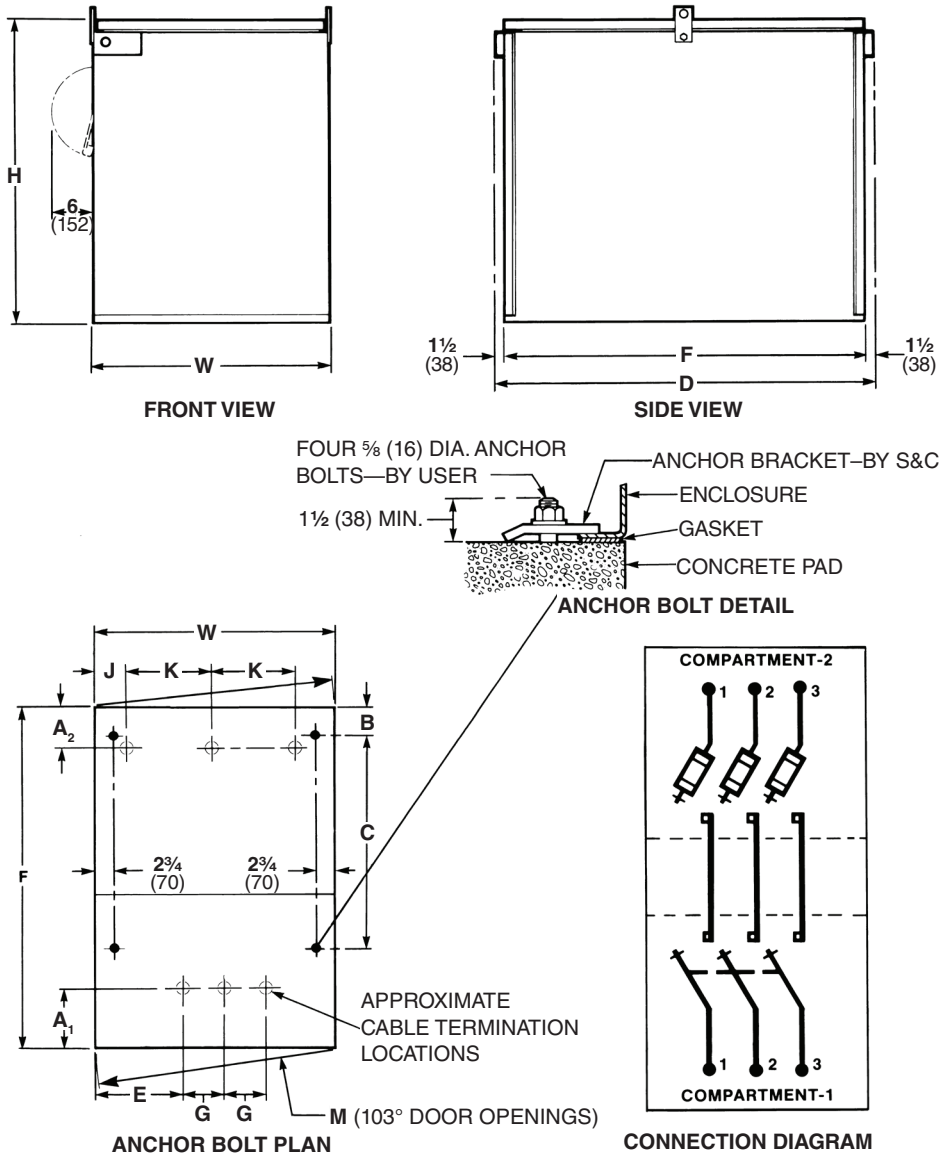

kV, Nominal	A ₁ ●	A ₂	B	C	D	E	F	G	H	J	K	M	W
14.4	9⅞ (251)	7 (178)	5⅞ (130)	31 (787)	54¾ (1391)	12⅞ (327)	51¼ (1314)	6 (152)	44 (1118)	4⅞ (124)	9¼ (248)	34 (864)	34⅞ (886)
25	14⅞ (359)	11¼ (286)	7⅞ (181)	51 (1295)	68¼ (1734)	13¾ (349)	65¼ (1657)	7½ (191)	55 (1397)	6⅞ (168)	12½ (318)	42½ (1080)	43 (1092)

● When catalog number suffix "-M1," "-U2," or "-U3" is specified, cable-termination locations will be slightly affected. Consult the nearest S&C Sales Office for details.

Model PMH-6
14.4 kV and 25 kV Nominal

Dimensions in inches (mm)

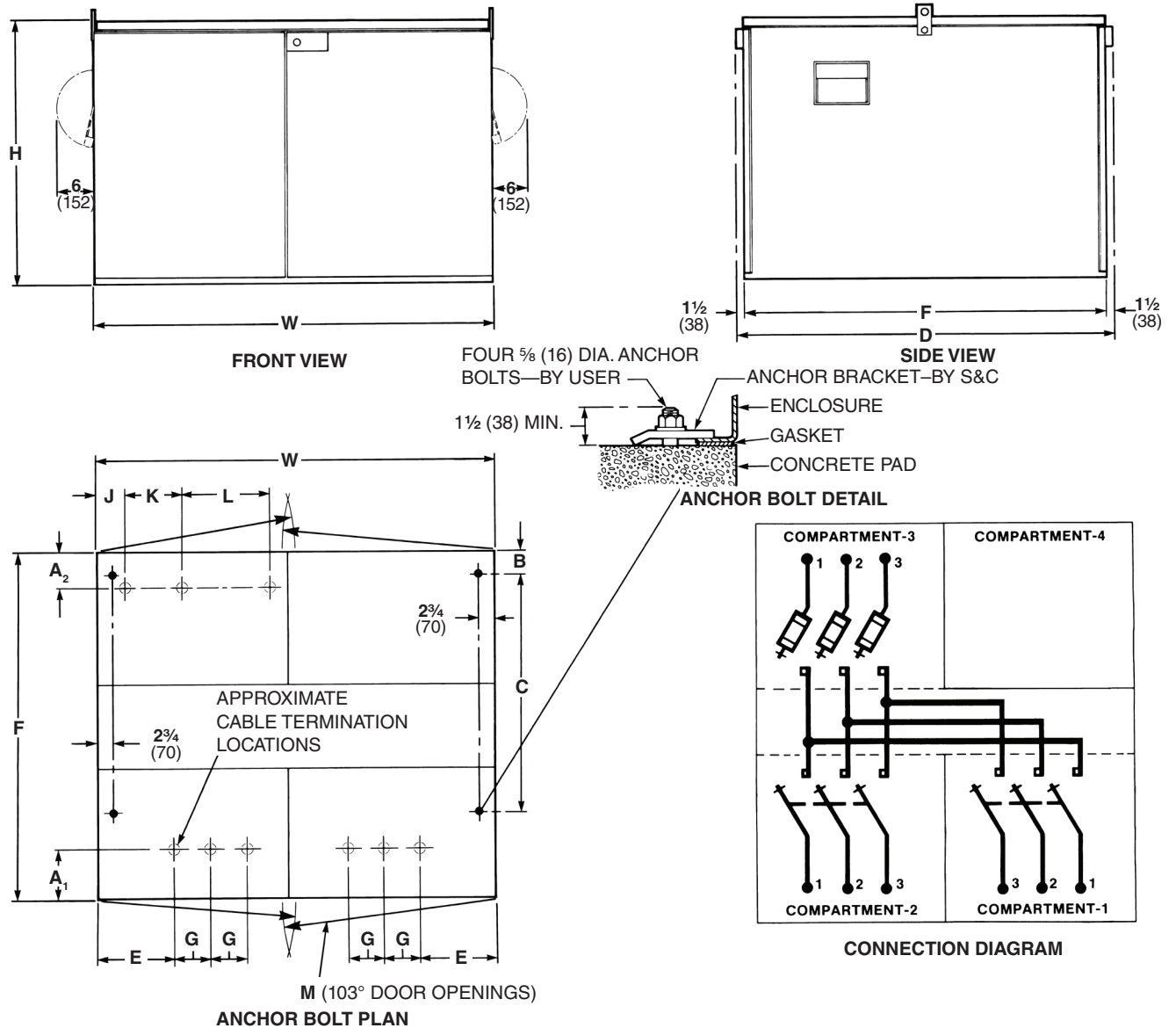

kV, Nominal	A ₁ ●	A ₂	B	C	D	E	F	G	H	J	K	L	M	W
14.4	9 7/8 (251)	7 (178)	5 1/8 (130)	40 (1016)	63 3/4 (1619)	12 7/8 (327)	60 3/4 (1543)	6 (152)	44 (1118)	4 3/4 (121)	9 3/4 (248)	14 3/4 (375)	34 (864)	67 (1702)
25	14 1/8 (359)	11 1/4 (286)	7 1/8 (181)	62 1/2 (1588)	79 3/4 (2026)	13 3/4 (349)	76 3/4 (1949)	7 1/2 (191)	55 (1397)	6 (152)	12 1/2 (318)	16 1/2 (419)	41 1/2 (1054)	82 (2083)

● When catalog number suffix "-M1," "-U2," or "-U3" is specified, cable-termination locations will be slightly affected. Consult the nearest S&C Sales Office for details.

Ordering Tables

Model PMH-7

14.4 kV and 25 kV Nominal

Dimensions in inches (mm)

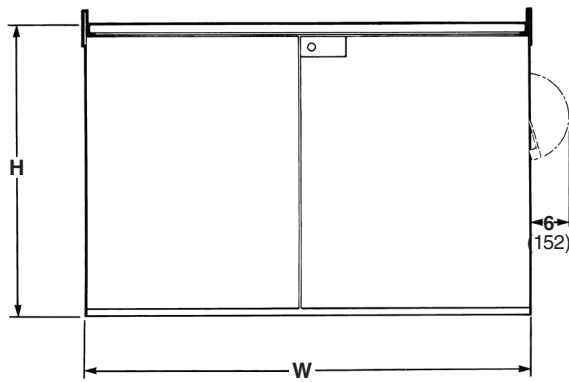

FRONT VIEW

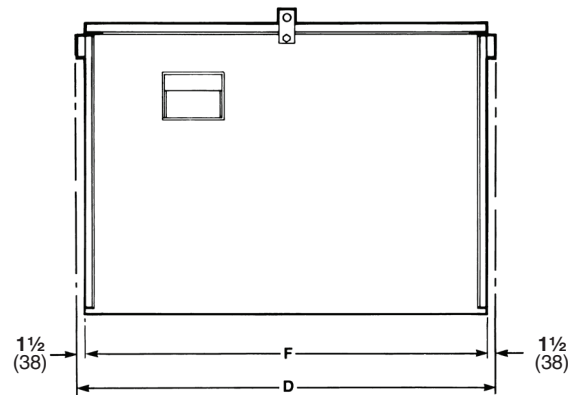

SIDE VIEW

FOUR 5/8 (16) DIA. ANCHOR BOLTS—BY USER

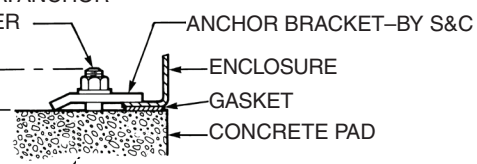

ANCHOR BOLT DETAIL

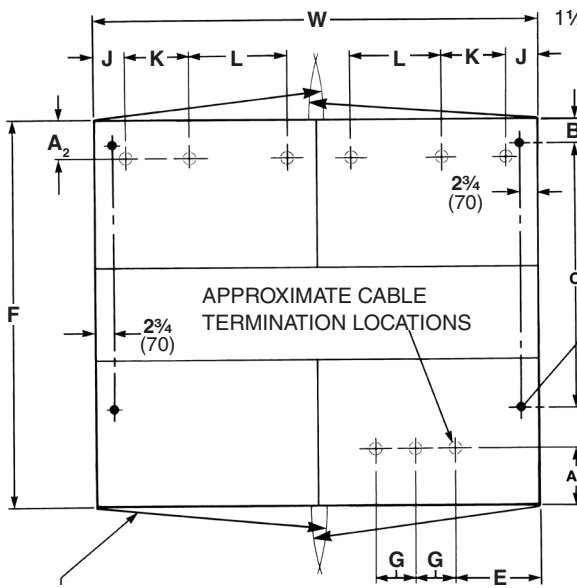

ANCHOR BOLT PLAN

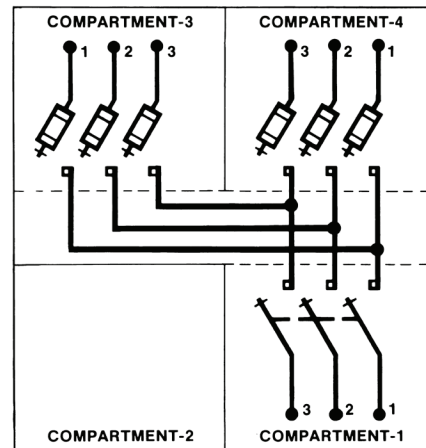

CONNECTION DIAGRAM

kV, Nominal	A ₁ ●	A ₂	B	C	D	E	F	G	H	J	K	L	M	W
14.4	9 7/8 (251)	7 (178)	5 1/8 (130)	40 (1016)	63 3/4 (1619)	12 7/8 (327)	60 3/4 (1543)	6 (152)	44 (1118)	4 3/4 (121)	9 3/4 (248)	14 3/4 (375)	34 (864)	67 (1702)
25	14 1/8 (359)	11 1/4 (286)	7 1/8 (181)	62 1/2 (1588)	79 3/4 (2026)	13 3/4 (349)	76 3/4 (1949)	7 1/2 (191)	55 (1397)	6 (152)	12 1/2 (318)	16 1/2 (419)	41 1/2 (1054)	82 (2083)

● When catalog number suffix “-M1,” “-U2,” or “-U3” is specified, cable-termination locations will be slightly affected. Consult the nearest S&C Sales Office for details.

Model PMH-8
14.4 kV and 25 kV Nominal

Dimensions in inches (mm)

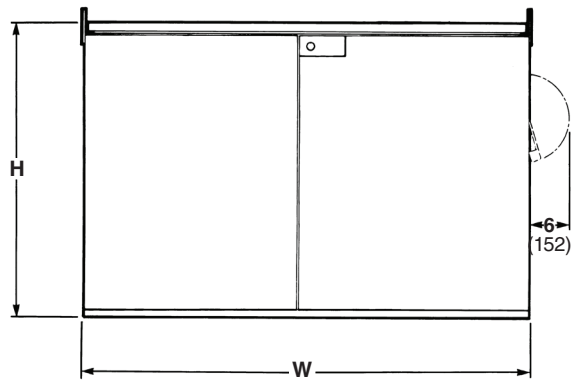

FRONT VIEW

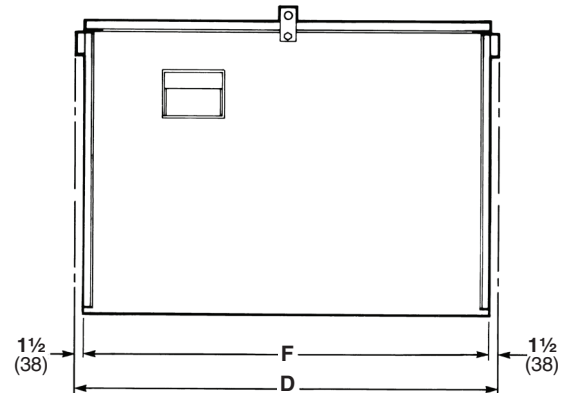

SIDE VIEW

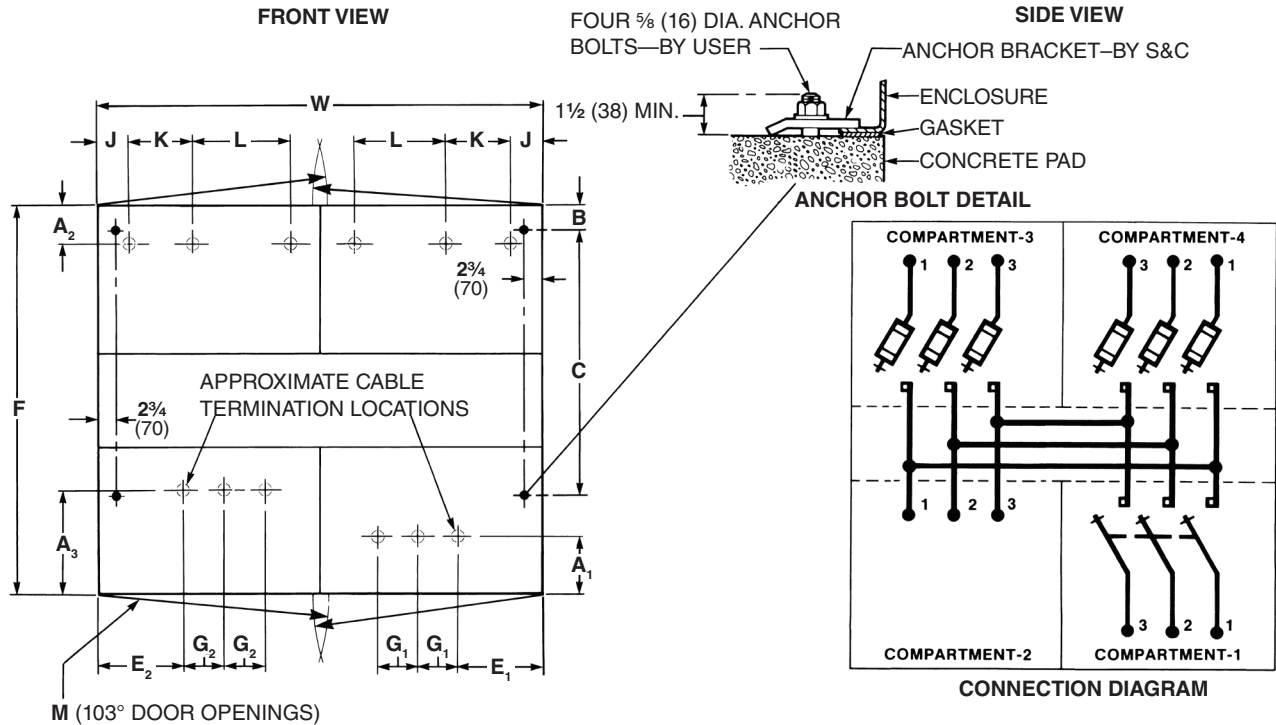

ANCHOR BOLT PLAN

kV, Nominal	A ₁ ●	A ₂	A ₃ ●	B	C	D	E ₁	E ₂	F	G ₁	G ₂	H	J	K	L	M	W
14.4	9 ⁷ / ₈ (251)	7 (178)	19 (483)	5 ¹ / ₈ (130)	40 (1016)	63 ³ / ₄ (1619)	12 ⁷ / ₈ (327)	8 ³ / ₄ (222)	60 ³ / ₄ (1543)	6 (152)	9 ¹ / ₄ (235)	44 (1118)	4 ³ / ₄ (121)	9 ³ / ₄ (248)	14 ³ / ₄ (375)	34 (864)	67 (1702)
25	14 ¹ / ₈ (359)	11 ¹ / ₄ (286)	18 ³ / ₄ (476)	7 ¹ / ₈ (181)	62 ¹ / ₂ (1588)	79 ³ / ₄ (2026)	13 ³ / ₄ (349)	8 ¹ / ₁₆ (205)	76 ³ / ₄ (1949)	7 ¹ / ₂ (191)	12 ¹ / ₂ (318)	55 (1397)	6 (152)	12 ¹ / ₂ (318)	16 ¹ / ₂ (419)	41 ¹ / ₂ (1054)	82 (2083)

● When catalog number suffix “-M1,” “-U2,” or “-U3” is specified, cable-termination locations will be slightly affected. Consult the nearest S&C Sales Office for details.

Ordering Tables

Model PMH-9

14.4 kV and 25 kV Nominal

Dimensions in inches (mm)

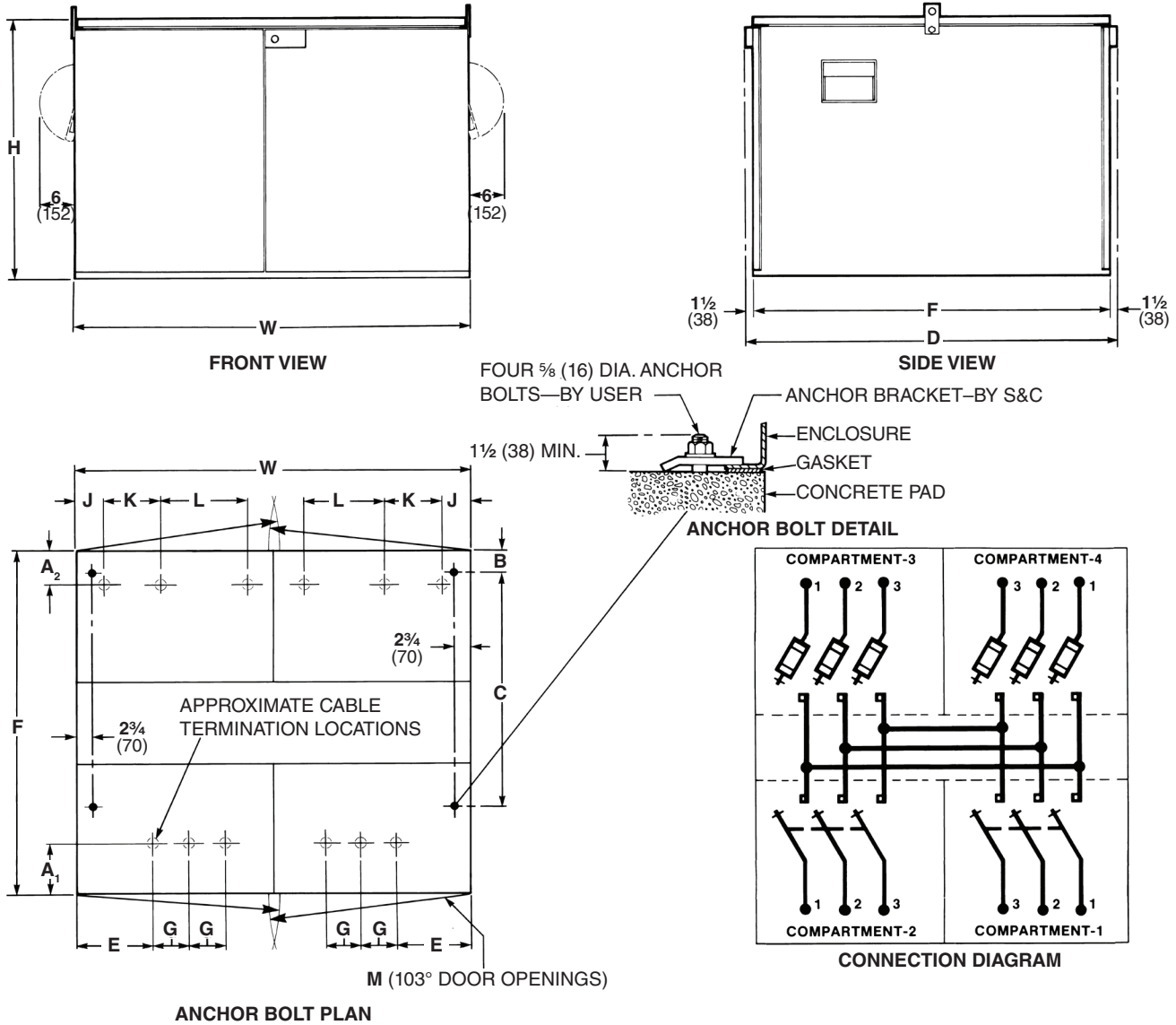

kV, Nominal	A ₁ ●	A ₂	B	C	D	E	F	G	H	J	K	L	M	W
14.4	9 7/8 (251)	7 (178)	5 1/8 (130)	40 (1016)	63 3/4 (1619)	12 7/8 (327)	60 3/4 (1543)	6 (152)	44 (1118)	4 3/4 (121)	9 3/4 (248)	14 3/4 (375)	34 (864)	67 (1702)
25	14 1/8 (359)	11 1/4 (286)	7 1/8 (181)	62 1/2 (1588)	79 3/4 (2026)	13 3/4 (349)	76 3/4 (1949)	7 1/2 (191)	55 (1397)	6 (152)	12 1/2 (318)	16 1/2 (419)	41 1/2 (1054)	82 (2083)

● When catalog number suffix "-M1," "-U2," or "-U3" is specified, cable-termination locations will be slightly affected. Consult the nearest S&C Sales Office for details.

Model PMH-10
14.4 kV and 25 kV Nominal

Dimensions in inches (mm)

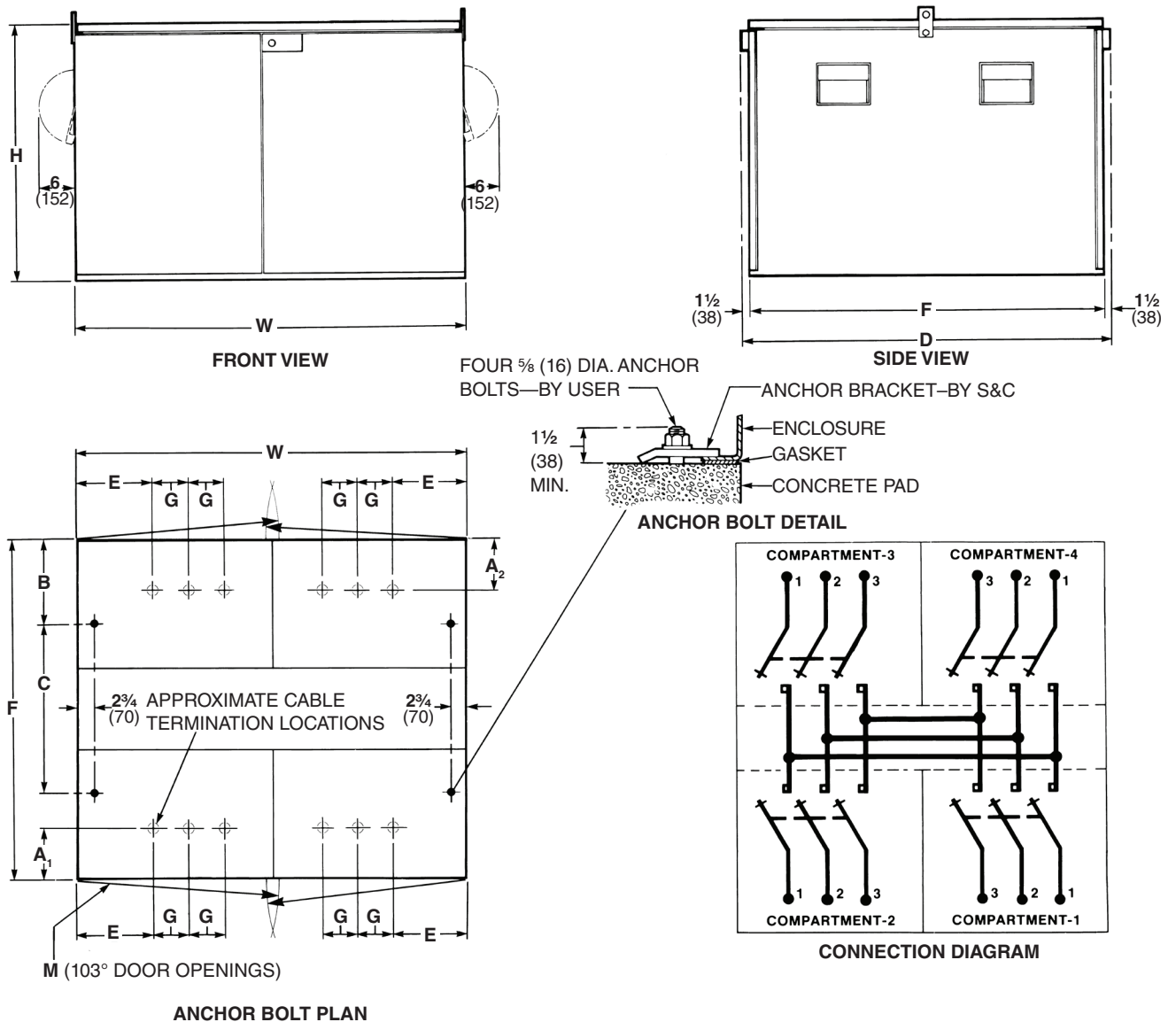

kV, Nominal	A ₁ ●	A ₂ ●	B	C	D	E	F	G	H	M	W
14.4	9 7/8 (251)	9 1/8 (232)	15 5/8 (397)	29 1/2 (749)	63 3/4 (1619)	12 7/8 (327)	60 3/4 (1543)	6 (152)	44 (1118)	34 (864)	67 (1702)
25	14 1/8 (359)	14 1/8 (359)	7 1/8 (181)	62 1/2 (1588)	79 3/4 (2026)	13 3/4 (349)	76 3/4 (1949)	7 1/2 (191)	55 (1397)	41 1/2 (1054)	82 (2083)

● When catalog number suffix "-M1," "-U2," or "-U3" is specified, cable-termination locations will be slightly affected. Consult the nearest S&C Sales Office for details.

Ordering Tables

Model PMH-11

14.4 kV and 25 kV Nominal

Dimensions in inches (mm)

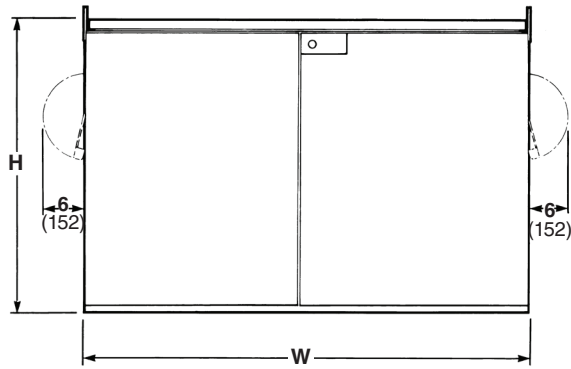

FRONT VIEW

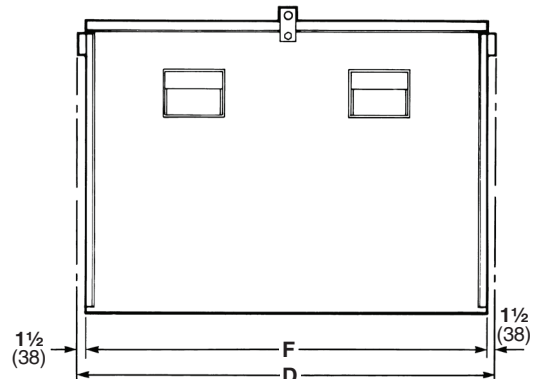

SIDE VIEW

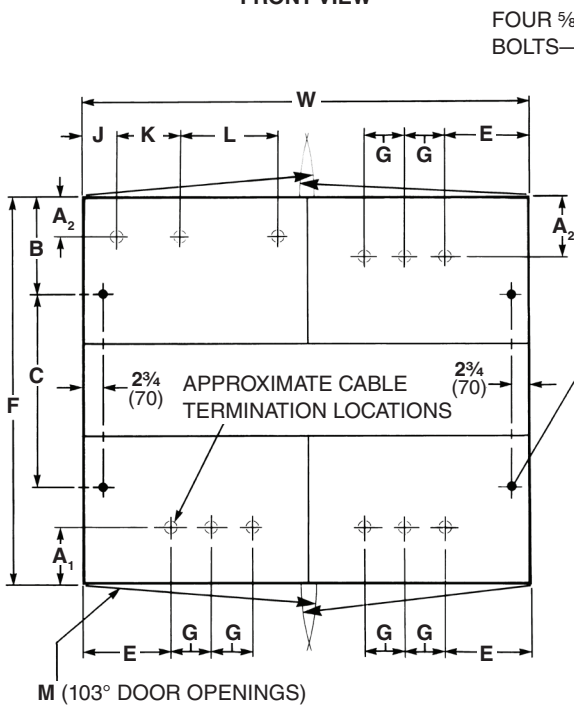

ANCHOR BOLT PLAN

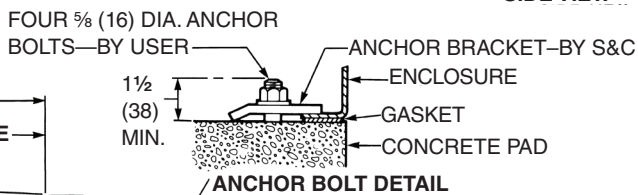

ANCHOR BOLT DETAIL

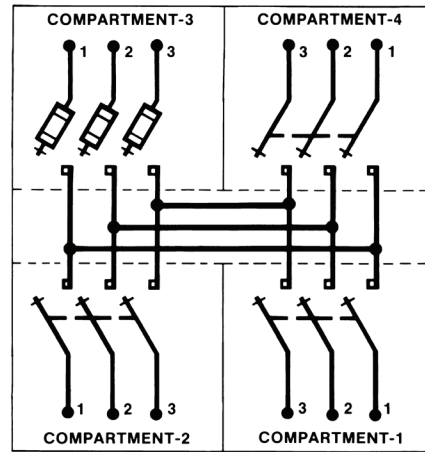

CONNECTION DIAGRAM

kV, Nominal	A ₁ ●	A ₂	B	C	D	E	F	G	H	J	K	L	M	W
14.4	9 ⁷ / ₈ (251)	7 (178)	15 ⁵ / ₈ (397)	40 (1016)	63 ³ / ₄ (1619)	12 ⁷ / ₈ (327)	60 ³ / ₄ (1543)	6 (152)	44 (1118)	4 ³ / ₄ (121)	9 ³ / ₄ (248)	14 ³ / ₄ (375)	34 (864)	67 (1702)
25	14 ¹ / ₈ (359)	11 ¹ / ₄ (286)	7 ¹ / ₈ (181)	62 ¹ / ₂ (1588)	79 ³ / ₄ (2026)	13 ³ / ₄ (349)	76 ³ / ₄ (1949)	7 ¹ / ₂ (191)	55 (1397)	6 (152)	12 ¹ / ₂ (318)	16 ¹ / ₂ (419)	41 ¹ / ₂ (1054)	82 (2083)

● When catalog number suffix "-M1," "-U2," or "-U3" is specified, cable-termination locations will be slightly affected. Consult the nearest S&C Sales Office for details.

Model PMH-12

14.4 kV and 25 kV Nominal

Dimensions in inches (mm)

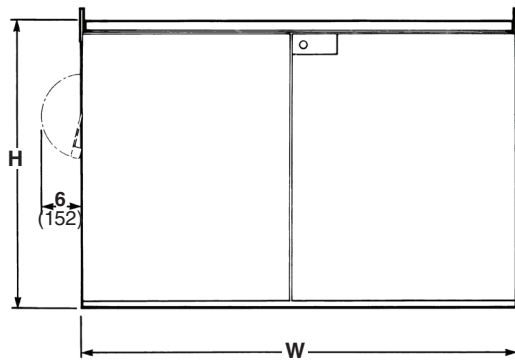

FRONT VIEW

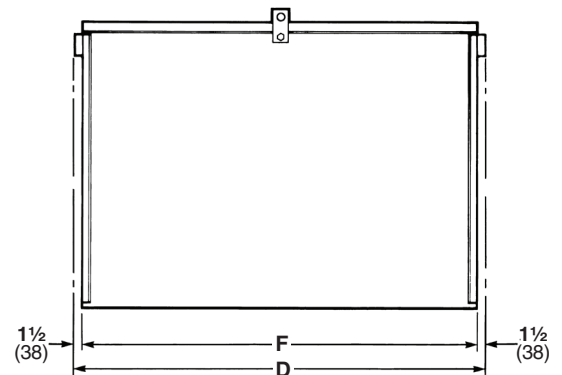

SIDE VIEW

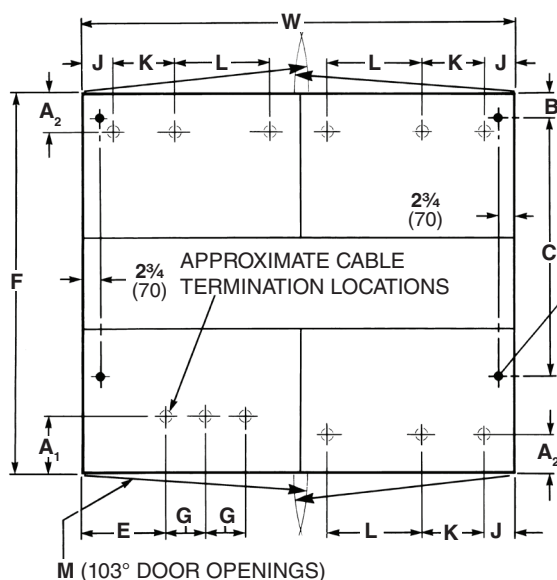

ANCHOR BOLT PLAN

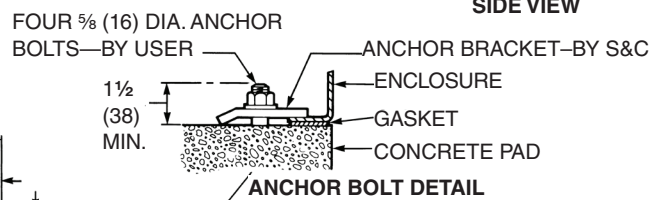

ANCHOR BOLT DETAIL

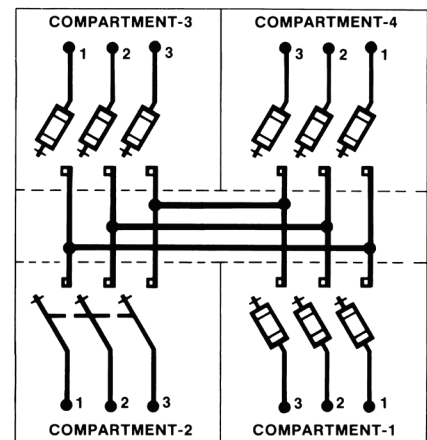

CONNECTION DIAGRAM

kV, Nominal	A ₁ ●	A ₂	B	C	D	E	F	G	H	J	K	L	M	W
14.4	9 ⁷ / ₈ (251)	7 (178)	5 ¹ / ₈ (130)	40 (1016)	63 ³ / ₄ (1619)	12 ⁷ / ₈ (327)	60 ³ / ₄ (1543)	6 (152)	44 (1118)	4 ³ / ₄ (121)	9 ³ / ₄ (248)	14 ³ / ₄ (375)	34 (864)	67 (1702)
25	14 ¹ / ₈ (359)	11 ¹ / ₄ (286)	7 ¹ / ₈ (181)	62 ¹ / ₂ (1588)	79 ³ / ₄ (2026)	13 ³ / ₄ (349)	76 ³ / ₄ (1949)	7 ¹ / ₂ (191)	55 (1397)	6 (152)	12 ¹ / ₂ (318)	16 ¹ / ₂ (419)	41 ¹ / ₂ (1054)	82 (2083)

● When catalog number suffix “-M1,” “-U2,” or “-U3” is specified, cable-termination locations will be slightly affected. Consult the nearest S&C Sales Office for details.

Ordering Tables

Model PMH-13

14.4 kV and 25 kV Nominal

Dimensions in inches (mm)

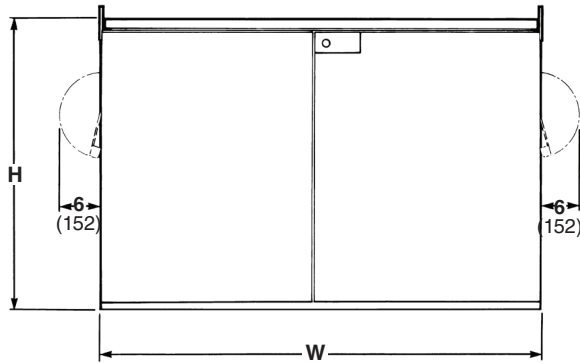

FRONT VIEW

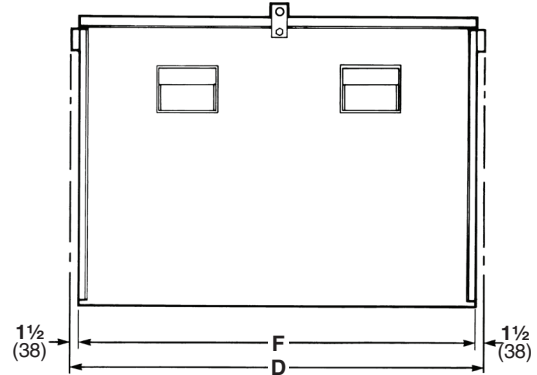

SIDE VIEW

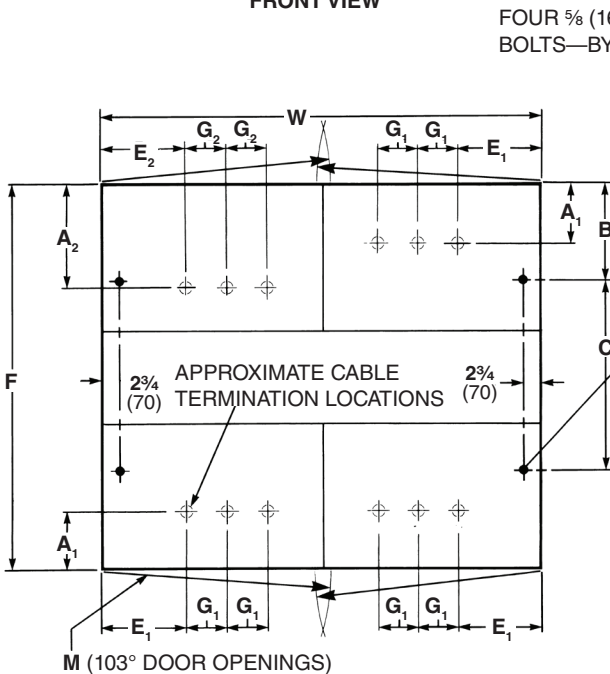

ANCHOR BOLT PLAN

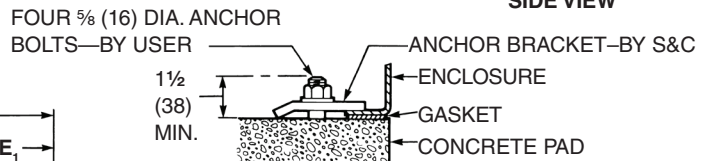

ANCHOR BOLT DETAIL

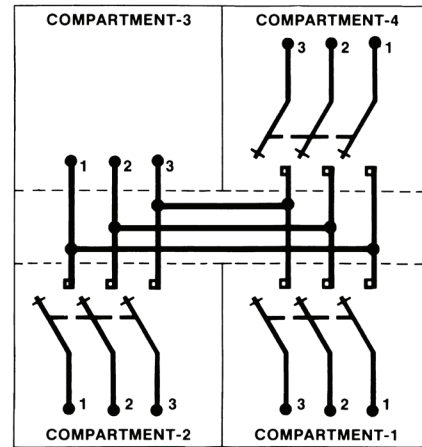

CONNECTION DIAGRAM

kV, Nominal	A ₁ ●	A ₂ ●	B	C	D	E ₁	E ₂	F	G ₁	G ₂	H	M	W
14.4	9 7/8 (251)	19 (483)	15 5/8 (397)	29 1/2 (749)	63 3/4 (1619)	12 7/8 (327)	8 3/4 (222)	60 3/4 (1543)	6 (152)	9 1/4 (235)	44 (1118)	34 (864)	67 (1702)
25	14 1/8 (359)	18 3/4 (476)	7 1/8 (181)	62 1/2 (1588)	79 3/4 (2026)	13 3/4 (349)	8 1/16 (205)	76 3/4 (1949)	7 1/2 (191)	12 1/2 (318)	55 (1397)	41 1/2 (1054)	82 (2083)

● When catalog number suffix “-M1,” “-U2,” or “-U3” is specified, cable-termination locations will be slightly affected. Consult the nearest S&C Sales Office for details.

Model PMH-19
14.4 kV Nominal

Dimensions in inches (mm)

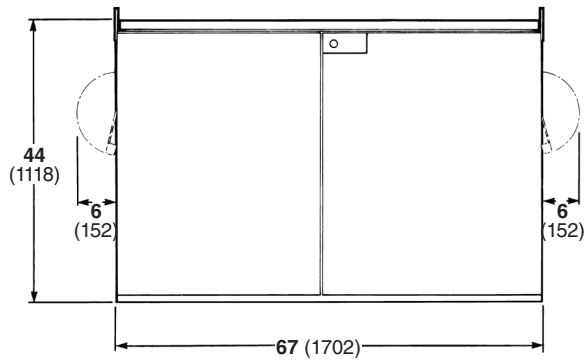

FRONT VIEW

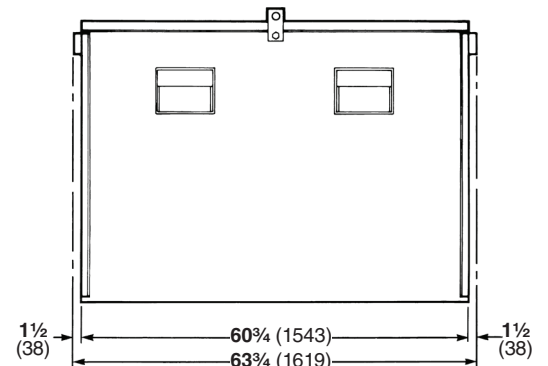

SIDE VIEW

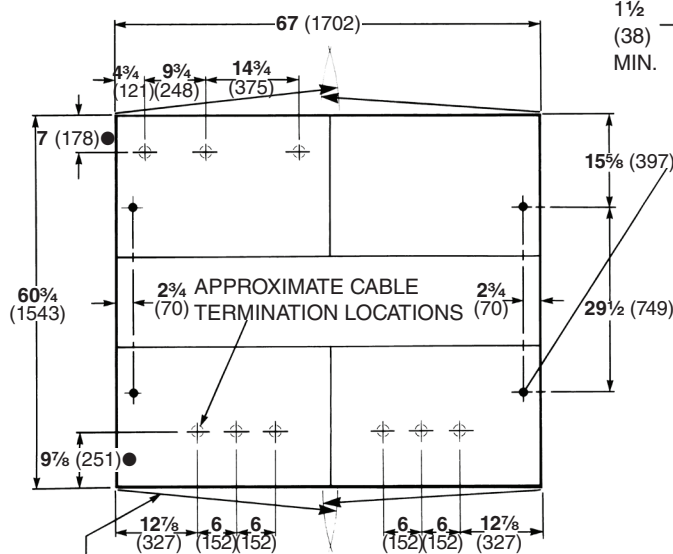

ANCHOR BOLT PLAN

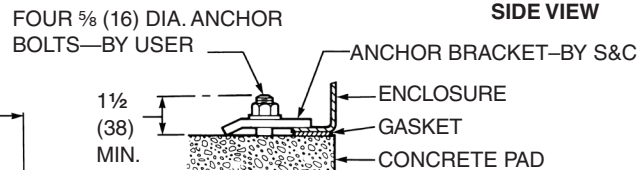

ANCHOR BOLT DETAIL

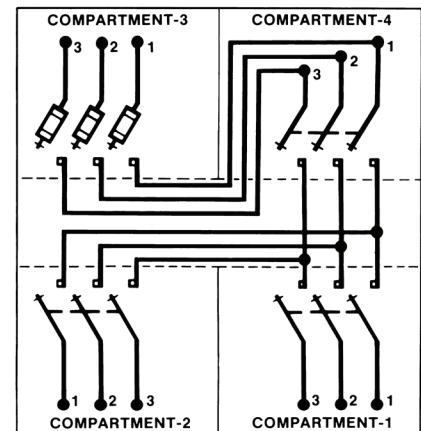

CONNECTION DIAGRAM

● When catalog number suffix "-M1," "-U2," or "-U3" is specified, cable-termination locations will be slightly affected. Consult the nearest S&C Sales Office for details.