

Installation

Table of Contents

Introduction	2	Installation	8
Qualified Persons	2	Before Starting	8
Read this Instruction Sheet	2	Connecting the Switch Operator to the Alduti- Rupter Switch's Vertical Operating Shaft.....	12
Retain this Instruction Sheet.....	2	Making Conduit Connections and Connecting External Control-Circuit Wiring.....	13
Proper Application.....	2	Using the Manual Operating Handle.....	14
Warranty.....	3	Using the Selector Handle (Coupling and Decoupling)	15
Safety Information	4	Adjusting the Position Indicator and Cranking Direction.....	17
Understanding Safety-Alert Messages	4	Adjusting the Travel-Limit Discs After Motor Direction Reversal.....	19
Following Safety Instructions.....	4	Intermediate Adjustment of Travel-Limit Discs.....	21
Replacement Instructions and Labels	4	Final Adjustment of Travel-Limit Cams.....	21
Location of Safety Labels.....	5	Adjusting the Auxiliary Switches	23
Safety Precautions	6	Adjusting the Extra Auxiliary Switches.....	25
Shipping and Handling	7	Checking Switch Operator and Alduti-Rupter Switch Positions Before Energization.....	26
Inspection	7	Final Checks Before Walking Away	26
Packing.....	7	Appendix	27
Storage.....	7	For Type AS-1A Switch Operators Furnished With Source-Transfer Control Compatibility (Suffix “-U1”).....	27
Handling.....	7		

★For use with S&C Alduti-Rupter® Switches



Introduction

Qualified Persons

WARNING

Only qualified persons knowledgeable in the installation, operation, and maintenance of overhead and underground electric distribution equipment, along with all associated hazards, may install, operate, and maintain the equipment covered by this publication. A qualified person is someone trained and competent in:

- The skills and techniques necessary to distinguish exposed live parts from nonlive parts of electrical equipment
- The skills and techniques necessary to determine the proper approach distances corresponding to the voltages to which the qualified person will be exposed
- The proper use of special precautionary techniques, personal protective equipment, insulated and shielding materials, and insulated tools for working on or near exposed energized parts of electrical equipment

These instructions are intended only for such qualified persons. They are not intended to be a substitute for adequate training and experience in safety procedures for this type of equipment.

Read this Instruction Sheet

NOTICE

Thoroughly and carefully read this instruction sheet and all materials included in the product's instruction handbook before installing or operating a S&C Type AS-1A Switch Operator. Become familiar with the Safety Information and Safety Precautions on pages 4 through 6. The latest version of this publication is available online in PDF format at sandc.com/en/contact-us/product-literature/.

Retain this Instruction Sheet

This instruction sheet is a permanent part of the S&C Type AS-1A Switch Operator. Designate a location where users can easily retrieve and refer to this publication.

Proper Application

WARNING

The equipment in this publication is only intended for a specific application. The application must be within the ratings furnished for the equipment. Ratings for S&C Type AS-1A Switch Operators are listed in the ratings table in Specification Bulletin 769-31. The ratings are also on the nameplate affixed to the product.

Warranty

The warranty and/or obligations described in S&C's Price Sheet 150, "Standard Conditions of Sale—Immediate Purchasers in the United States," (or Price Sheet 153, "Standard Conditions of Sale—Immediate Purchasers Outside the United States"), plus any special warranty provisions, as set forth in the applicable product-line specification bulletin, are exclusive. The remedies provided in the former for breach of these warranties shall constitute the immediate purchaser's or end user's exclusive remedy and a fulfillment of the seller's entire liability. In no event shall the seller's liability to the immediate purchaser or end user exceed the price of the specific product that gives rise to the immediate purchaser's or end user's claim. All other warranties, whether express or implied or arising by operation of law, course of dealing, usage of trade or otherwise, are excluded. The only warranties are those stated in Price Sheet 150 (or Price Sheet 153), and THERE ARE NO EXPRESS OR IMPLIED WARRANTIES OF MERCHANTABILITY OR FITNESS FOR A PARTICULAR PURPOSE. ANY EXPRESS WARRANTY OR OTHER OBLIGATION PROVIDED IN PRICE SHEET 150 (OR PRICE SHEET 153) IS GRANTED ONLY TO THE IMMEDIATE PURCHASER AND END USER, AS DEFINED THEREIN. OTHER THAN AN END USER, NO REMOTE PURCHASER MAY RELY ON ANY AFFIRMATION OF FACT OR PROMISE THAT RELATES TO THE GOODS DESCRIBED HEREIN, ANY DESCRIPTION THAT RELATES TO THE GOODS, OR ANY REMEDIAL PROMISE INCLUDED IN PRICE SHEET 150 (OR PRICE SHEET 153).

Safety Information

Understanding Safety-Alert Messages

Several types of safety-alert messages may appear throughout this instruction sheet and on labels and tags attached to the product. Become familiar with these types of messages and the importance of these various signal words:

DANGER

“DANGER” identifies the most serious and immediate hazards that will likely result in serious personal injury or death if instructions, including recommended precautions, are not followed.

WARNING

“WARNING” identifies hazards or unsafe practices that can result in serious personal injury or death if instructions, including recommended precautions, are not followed.

CAUTION

“CAUTION” identifies hazards or unsafe practices that can result in minor personal injury if instructions, including recommended precautions, are not followed.

NOTICE

“NOTICE” identifies important procedures or requirements that can result in product or property damage if instructions are not followed.

Following Safety Instructions

If any portion of this instruction sheet is unclear and assistance is needed, contact the nearest S&C Sales Office or S&C Authorized Distributor. Their telephone numbers are listed on S&C’s website sandc.com, or call the S&C Global Support and Monitoring Center at 1-888-762-1100.

NOTICE

Read this instruction sheet thoroughly and carefully before installing a Type AS-1A S&C Switch Operator.



Replacement Instructions and Labels

If additional copies of this instruction sheet are required, contact the nearest S&C Sales Office, S&C Authorized Distributor, S&C Headquarters, or S&C Electric Canada Ltd.

It is important that any missing, damaged, or faded labels on the equipment be replaced immediately. Replacement labels are available by contacting the nearest S&C Sales Office, S&C Authorized Distributor, S&C Headquarters, or S&C Electric Canada Ltd.

Location of Safety Labels



Reorder Information for Safety Labels

Location	Safety Alert Message	Description	Part Number
A	CAUTION	Use pushbuttons to open or close the switch....	G-4892R2
B	NOTICE	The S&C Instruction Sheet is a permanent part of your S&C Equipment....	G-3733R2
C	NOTICE	Auxiliary switch cams are individually adjustable. Check the auxiliary switch cams...	G-4747R2
D	NOTICE	This contactor or relay has been blocked to prevent damage during shipment.	G-3684●

- This tag is to be removed and discarded after the switch operator is installed and adjusted.

DANGER



Alduti-Rupter Switches operate at high voltage. Failure to observe the precautions below will result in serious personal injury or death.

Some of these precautions may differ from your company's operating procedures and rules. Where a discrepancy exists, follow your company's operating procedures and rules.

1. **QUALIFIED PERSONS.** Access to Alduti-Rupter Switches must be restricted only to qualified persons. See the "Qualified Persons" section on page 2.
2. **SAFETY PROCEDURES.** Always follow safe operating procedures and rules.
3. **PERSONAL PROTECTIVE EQUIPMENT.** Always use suitable protective equipment, such as rubber gloves, rubber mats, hard hats, safety glasses, and flash clothing, in accordance with safe operating procedures and rules.
4. **SAFETY LABELS.** Do not remove or obscure any of the "DANGER," "WARNING," "CAUTION," or "NOTICE" labels.
5. **OPERATING MECHANISM.** Power-operated Alduti-Rupter Switches contain fast-moving parts that can severely injure fingers. Do not remove or disassemble unless directed to do so by S&C Electric Company.
6. **ENERGIZED COMPONENTS.** Always consider all parts of the Alduti-Rupter Switch live until de-energized, tested, and grounded. Voltage levels can be as high as the peak line-to-ground voltage last applied to the unit. Units energized or installed near energized lines should be considered live until tested and grounded.
7. **GROUNDING.** The Alduti-Rupter Switch must be connected to a suitable earth ground at the base of the utility pole, or to a suitable building ground for testing, before energizing the switch and at all times when energized. The vertical operating shaft above the Type AS-1A Switch Operator must also be connected to a suitable earth ground.
The ground wire(s) must be bonded to the system neutral, if present. If the system neutral is not present, proper precautions must be taken to ensure the local earth ground, or building ground, cannot be severed or removed.
8. **LOAD-INTERRUPTER SWITCH POSITION.** Always confirm the **Open/Close** position of each switch.
 - Switches and terminal pads may be energized from either side.
 - Switches and terminal pads may be energized with the switches in any position.
9. **MAINTAINING PROPER CLEARANCE.** Always maintain proper clearance from energized components.

Inspection

Examine the shipment for external evidence of damage as soon after receipt as possible, preferably before removal from the carrier's conveyance. Check the bill of lading to verify all listed shipping skids, crates, cartons, and containers are present.

If there is visible loss and/or damage:

1. Notify the delivering carrier immediately.
2. Ask for a carrier inspection.
3. Note condition of shipment on all copies of the delivery receipt.
4. File a claim with the carrier.

If concealed damaged is discovered:

1. Notify the delivering carrier within 15 days of receipt of shipment.
2. Ask for a carrier inspection.
3. File a claim with the carrier.

Also, notify S&C Electric Company in all instances of loss or damage.

Packing

An S&C erection drawing is stored in a water-resistant envelope attached to the Alduti-Rupter Switch base or in the AS-1A Switch Operator's instruction book holder. The operator drawings will be included in the main drawing envelope. Study the erection drawing carefully and check the bill of material to make sure all parts are at hand.

S&C Switch Operator catalog number 38854R4 includes a 12-Vdc battery and constant-burden battery charger for connection to an S&C 30-Volt-Ampere Potential Device or other 120-Volt 60-Hertz source. Instructions for making connections to the constant-burden battery charger can be found in S&C Instruction Sheet 769-600.

Storage

NOTICE

Connect control power to the switch operator when storing it outdoors. The Type AS-1A Switch Operator is equipped with a space heater that must be energized during storage to prevent condensation and corrosion within the operator enclosure.

If the switch operator must be stored before installation, keep it in a clean, dry, corrosion-free area to protect it from damage. Make sure the crating rests firmly on the ground and is reasonably level. Shoring under the crate may be necessary if the ground is uneven. If storing outdoors, connect control power to the space heater inside the switch operator per the wiring diagram furnished.

Handling

Lift the Type AS-1A Switch Operator with a lifting sling looped around the switch operator output shaft. See Figure 1.



Figure 1. Lifting the switch operator.

Installation

Before Starting

The S&C AS-1A Switch Operator is a high-speed operator with an operating time not exceeding 0.75 seconds. It is expressly designed for power operation of S&C outdoor distribution Alduti-Rupter Switches and S&C outdoor distribution Alduti-Rupter Switches with Power Fuses having rotating-type operating mechanisms.

The high operating speed of the S&C Type AS-1A Switch Operator provides sufficient moving-contact velocity in the Alduti-Rupter Switch interrupters to ensure full interrupting capability and long operating life. The operator's high operating speed also provides adequate closing velocity for 25/34.5-kV and 34.5-kV three-pole side-break integer-style and three-pole vertical-break integer-style switches such that the side-break integer-style switches have a one-time duty-cycle fault-

closing rating of 15,000 amperes RMS, asymmetrical, and the vertical-break integer-style switches have one-time duty-cycle fault-closing ratings of 20,000 or 30,000 amperes RMS asymmetrical for switches rated 600 amperes or 1200 amperes respectively.

WARNING

Unauthorized changes should not be made to the wiring of the Type AS-1A Switch Operator. Should a control-circuit revision appear desirable, it should be made **ONLY** on the authority of a revised wiring diagram approved by both the user and S&C Electric Company. **Unauthorized changes may make the function of the operator unpredictable, causing damage to the operator, associated Alduti-Rupter Switch, and possible serious personal injury.**

Table 1. Switch Operators—Types AS-1A

Application		Motor and Control Voltage	Maximum Operating Time, Seconds ^①	Minimum Locked-Rotor Torque at Rated Control Voltage, Inch-Lbs.	Accelerating Current, Amperes	Catalog Number	Schematic Wiring Diagram Drawing Number
High-Voltage Device	Rating of High-Voltage Device						
Alduti-Rupter Switch	7.2 kV thru 46 kV	12 Vdc	0.75●	18 500	—	38854R4■	CDR-3127R1
		48 Vdc	0.75	21 500	80	38847R4-A	CDR-3113R1
		125 Vdc	0.75	21 500	30	38847R4-B	
		115 V 60 Hz	0.75	18 000	46	38847R4-D	CDR-3128R1▲
		230 V 60 Hz	0.75	18 000	23	38847R4-E	

① Based on minimum battery and external control wire size requirements specified in S&C Data Bulletin 753-60; the operating time will be less if larger than-minimum battery size and/or external control wire size is used.

● Applicable to Alduti-Rupter Switches with operating-mechanism rotation of 90 degrees; operating time will be greater if the switch has increased operating-mechanism rotation. The typical running speed of a switch operator output shaft is 26 revolutions per minute.

■ Includes 12-Vdc battery and constant-burden battery charger for connection to an S&C 30-Volt-Ampere Potential Device or other 120-Volt, 60-Hertz source.

▲ CDR-3205R1 for catalog numbers 38847R4-D and 38847R4-E when furnished with source-transfer control compatibility (suffix “-U1”).

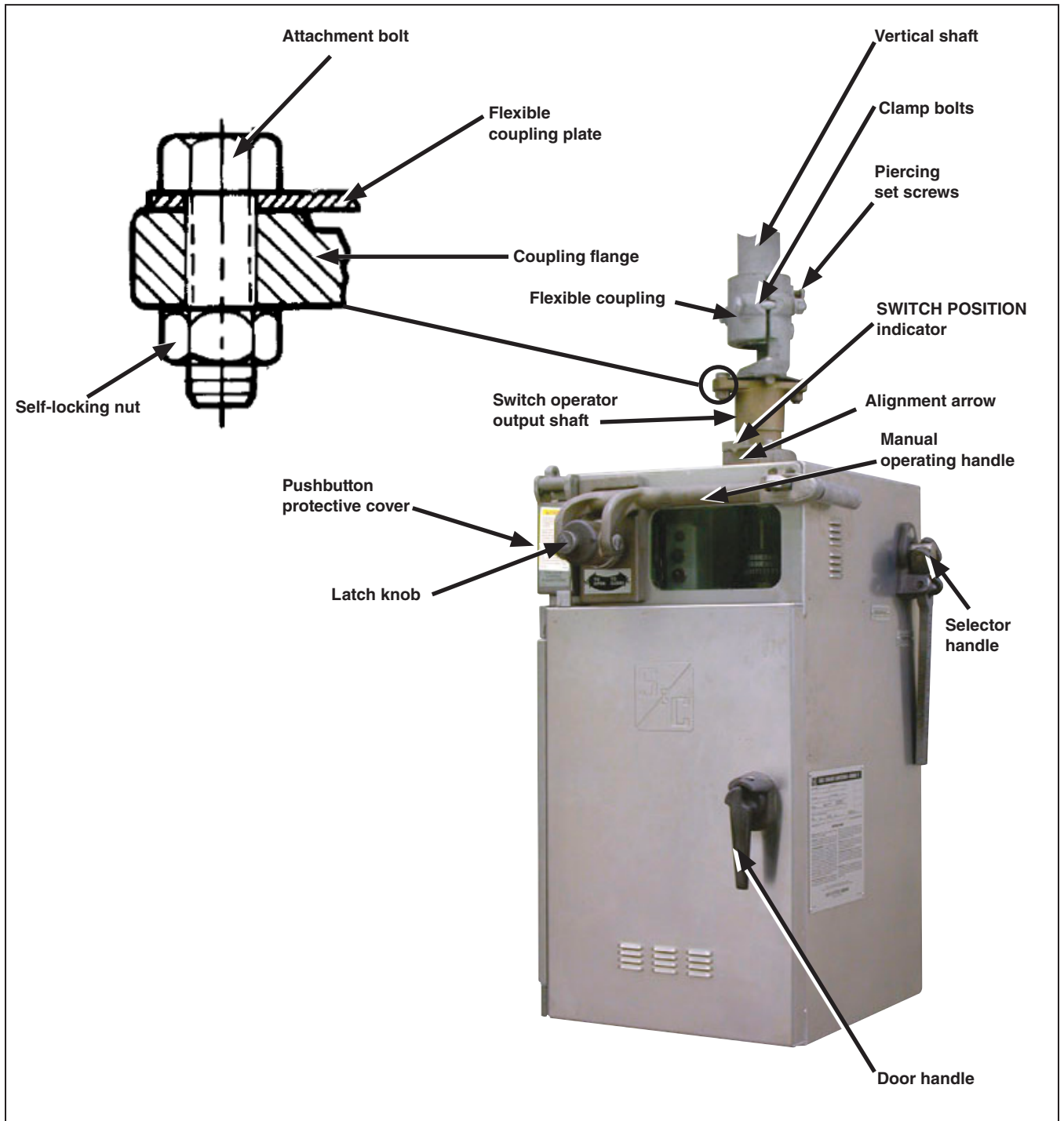

Figure 2. An external view of a Type AS-1A Switch Operator with the door closed.

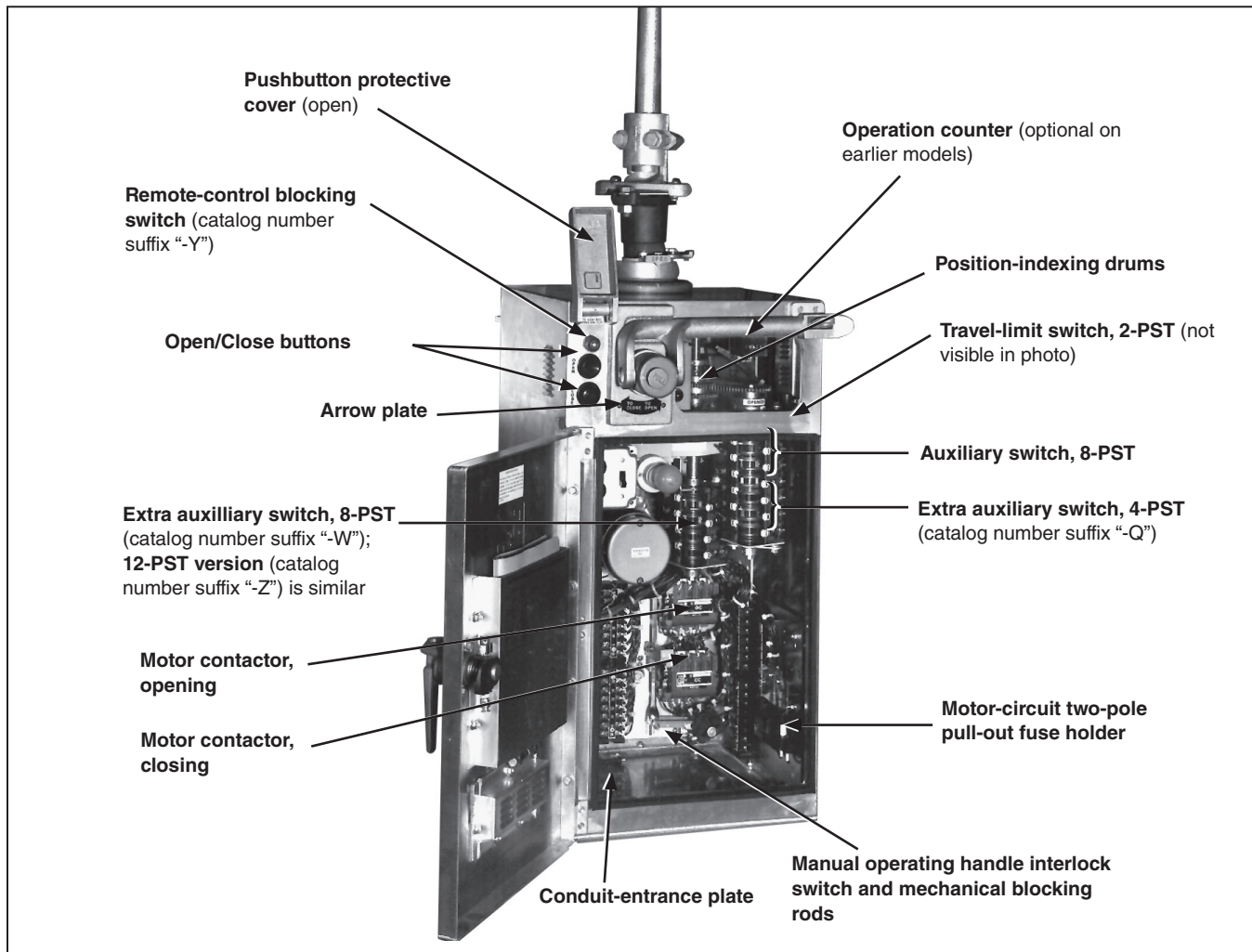

Figure 3. An interior view of a Type AS-1A Switch Operator with the door open.

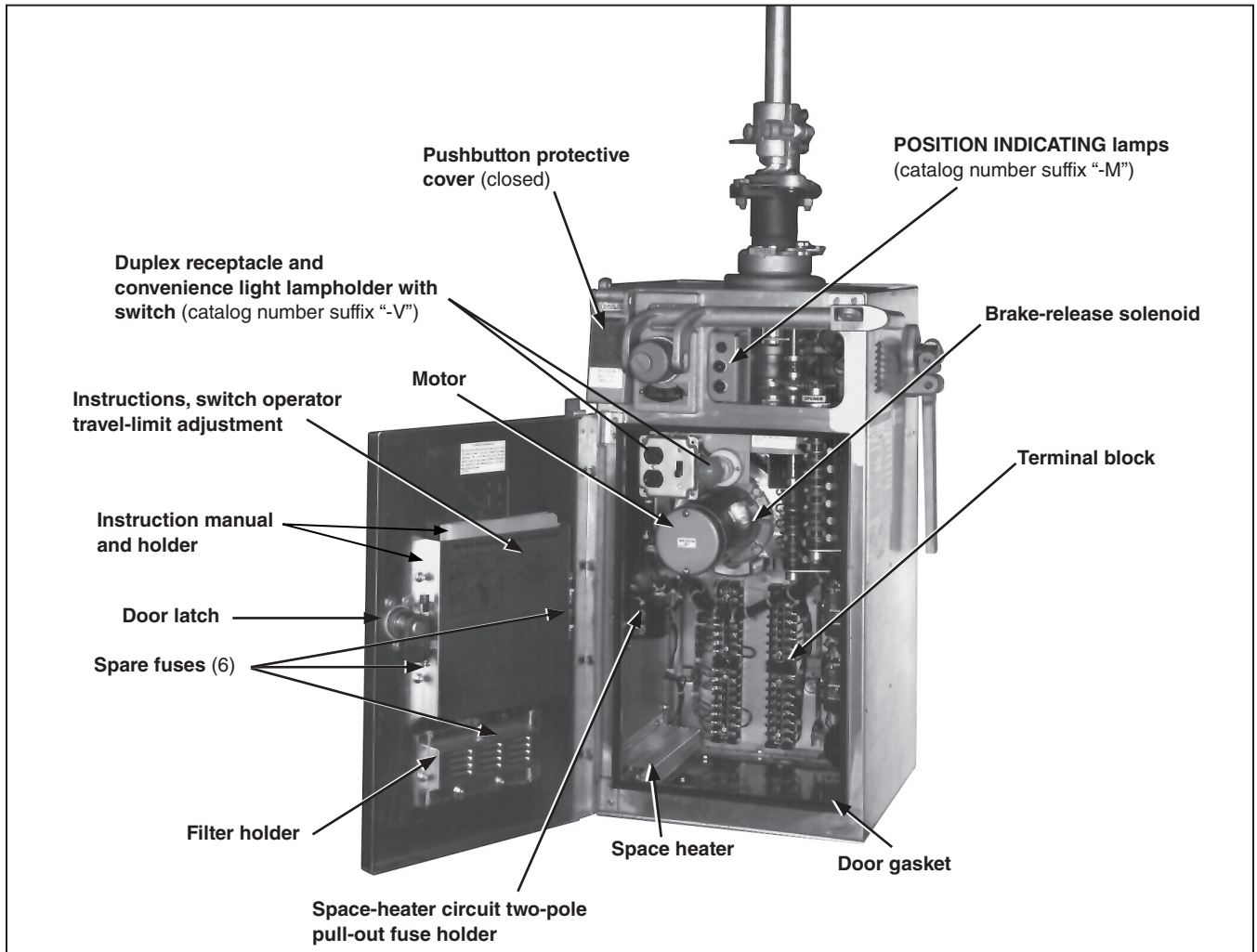

Figure 4. An interior view of a Type AS-1A Switch Operator.

NOTICE

These illustrations are not applicable to 12-Vdc models. Those models use a number of different component parts and a different internal layout. Among the differences is inclusion of a constant-burden battery charger mounted on a swing out panel and the use of a separate two-pole control-source disconnect switch in series with control-source fuses (located on the inside rear wall) in lieu of the motor-circuit two-pole pull-out fuse holder. Those models also include a separate compartment beneath the enclosure that houses the 12-Vdc battery.

Connecting the Switch Operator to the Alduti-Rupter Switch's Vertical Operating Shaft

Complete the following steps to connect the switch operator to the vertical operating shaft of the Alduti-Rupter Switch:

- STEP 1.** Lift the switch operator as shown in the "Handling" section on page 6. Then, mount the switch operator as indicated on the erection drawing.
- STEP 2.** Attach a flexible coupling to the output shaft of the switch operator. See Figure 2 on page 9 and Figure 5. Thread the attachment bolts through the flexible coupling plate and through the coupling flange on the output shaft. Tighten the bolts to draw the flexible plate flush against the flange; this will deform the threads in the flexible plate, resulting in a binding, nonslip connection.
- Install and tighten the self-locking nuts. *Do not* use lockwashers with the flexible coupling attachment bolts.
- STEP 3.** Remove the clamp bolts and set aside the detachable half of the flexible coupling.
- STEP 4.** Verify the cutting tips of the piercing set screws do not protrude through the body of the flexible coupling on the switch operator output shaft or protrude through the body of the universal coupling and thrust bearing at the upper guide bearing and universal coupling groups (or the body of the rigid coupling if an intermediate guide bearing assembly is used).
- STEP 5.** Pass the lowest section of vertical operating pipe up through the guide bearing and then through the thrust bearing, and insert the pipe section into the universal coupling (or, if an intermediate guide bearing assembly is used, pass the vertical-operating-pipe section up through the guide bearing and insert the pipe section into the rigid coupling). Figure 6.

Do not tighten the coupling clamp or piercing set screw at this time. (The lower end of the lowest section of vertical operating pipe will be cradled in the open flexible coupling attached to the output shaft of the switch operator.)

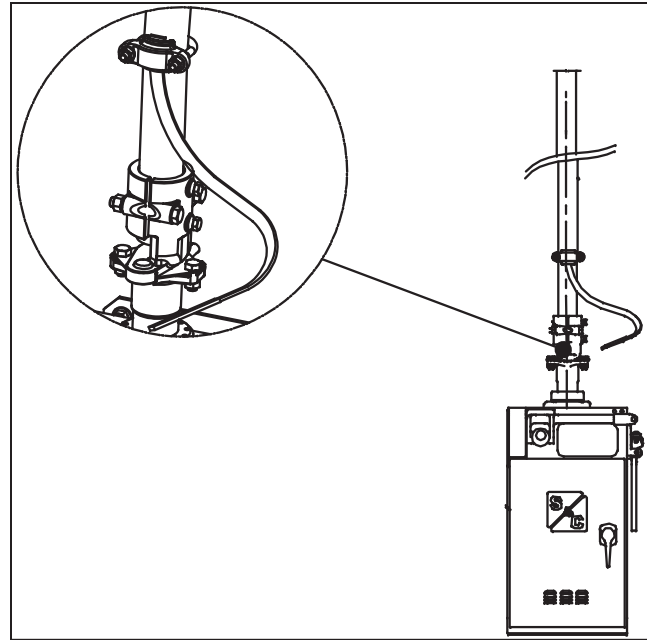

Figure 5. Ground connection to the Alduti-Rupter Switch's vertical operating pipe.

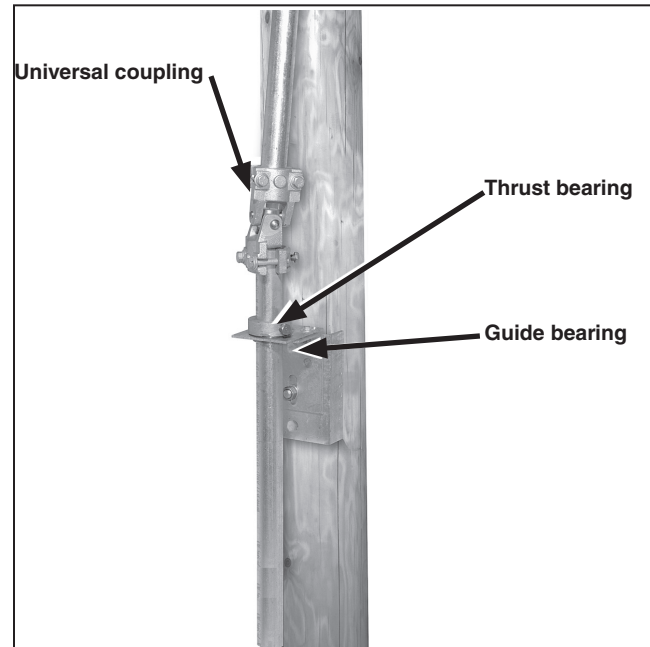

Figure 6. Position of the thrust and guide bearing. Thrust bearings will be positioned on top of guide bearings.

STEP 6. While holding the pipe section in this position, and with the thrust bearing resting on the guide bearing, tighten the piercing set screw in the thrust bearing, piercing the pipe, and continue turning until feeling a firm resistance. At the universal coupling, tighten the clamp bolt to final tightness, and then tighten the associated piercing set screw, piercing the pipe, and continue turning until feeling a firm resistance.

If an intermediate guide bearing assembly is used, tighten the clamp bolt on the rigid coupling to permanent tightness. Then, tighten the associated piercing set screw, piercing the pipe, and continue turning until feeling a firm resistance.

Making Conduit Connections and Connecting External Control-Circuit Wiring

NOTICE

To avoid accidental energizing of the operator after the external connections have been completed, remove the two-pole pull-out fuse holders for the motor and space heater. See Figure 3 on page 10 and Figure 4 on page 11. Reinsert the fuse holders only when indicated in the steps that follow.

- STEP 1.** Mark the conduit-entrance location for the control-circuit wiring on the conduit-entrance plate in the bottom of the switch operator enclosure. See Figure 3 on page 10.
- STEP 2.** Remove the conduit-entrance plate and cut out the required opening.
- STEP 3.** Replace the plate and make up the entrance fittings. Apply sealing compound (provided with each switch operator) when replacing the conduit entrance plate. Verify the entrance fittings are properly sealed to prevent water ingress.
- STEP 4.** Remove the blocking from the motor contactors.
- STEP 5.** Connect the external control-circuit wiring (including space-heater source leads) to the terminal blocks of the switch operator in accordance with the wiring diagram furnished.

For 12-Vdc models: Mount the battery in the battery compartment and connect it to the battery cables located at the rear of the battery compartment.

NOTICE

Direct-current switch operators are furnished with polarity-sensitive motors. Observe the polarities indicated on the wiring diagram for switch operator motor when making external control-circuit connections.

⚠ WARNING

Do not make unauthorized changes in the wiring of this switch operator. **Unauthorized changes may result in equipment damage or personal injury.**

1. To make a control-circuit modification, request a revised wiring diagram from S&C Electric Company.
2. The diagram must meet with the approval of both the user and S&C Electric Company.

NOTICE

Control-circuit wiring *must* meet minimum size requirements, as specified in S&C Data Bulletin 769-60 and on the switch operator wiring diagram furnished.

Installation

Using the Manual Operating Handle

The manual operating handle is used during switch operator adjustment. Become familiar with the operation of the manual operating handle, as described on the switch operator nameplate on the right-hand side of the enclosure.

WARNING

DO NOT manually open or close the switch operator while the Alduti-Rupter Switch is energized.

Operating the switch under reduced operating speed may cause excessive arcing, resulting in shortened interrupter life, damage to the interrupters, or personal injury.

If switch operator control voltage is not available and emergency manual opening is absolutely necessary, crank the manual operating handle rapidly throughout its full travel. **Do not** stop or hesitate part way. Never close the switch manually.

STEP 1. Pull the latch knob on the hub of the manual operating handle and pivot the handle forward slightly from its **Storage** position.

STEP 2. Release the latch knob while continuing to pivot the handle forward to lock it into the cranking position. See Figure 7. (As the handle is pivoted forward the motor brake is mechanically released, both leads of the control source are automatically disconnected, and—except for 12-Vdc models—both the “opening” and “closing” motor contactors are mechanically blocked in the **Open** position.)

STEP 3. Crank the handle in the direction shown on the arrow plate for the **Open** position.

If desired, during manual operation, the switch operator may also be disconnected from the control source by removing the motor-circuit two-pole pull-out fuse holder located on the right-hand inside wall of the enclosure.

STEP 4. To return the manual operating handle to its Storage position: Pull the latch knob and pivot the handle approximately 90 degrees. The handle will then be disengaged from the switch operator and may be rotated freely in either direction to its **Storage** position.

Complete the handle storage by pivoting the operating handle backward approximately 90 degrees until it latches in the **Storage** position. Always padlock the handle in its **Storage** position.

Note: The manual operating handle may be disengaged from the switch operator mechanism at any position of the handle.



Figure 7. Manual operation.

Using the Selector Handle (Coupling and Decoupling)

The selector handle will be used during switch operator adjustment. The integral external selector handle, for operation of the built-in internal decoupling mechanism, is located on the right-hand side of the switch operator enclosure. Become familiar with the operation of the selector handle, as described on the switch operator nameplate on the right-hand side of the enclosure.

To decouple the switch operator from the switch:

- STEP 1.** Swing the selector handle upright and *slowly* rotate it clockwise 50 degrees to the **Decoupled** position. See Figure 8. This decouples the switch operator mechanism from the switch operator output shaft.
- STEP 2.** Lower the selector handle to engage the locking tab. When decoupled, the switch operator may be operated either manually or electronically without operating the Aldu-ti-Rupter Switch.

When the selector handle is in the **Decoupled** position, the output shaft is prevented from moving by a mechanical locking device located within the switch operator enclosure.

During the intermediate segment of the selector handle travel, which includes the position at which actual disengagement (or engagement) of the internal decoupling mechanism occurs, the motor circuit source leads are momentarily disconnected and (except for 12-Vdc models) both the “opening” and “closing” motor contactors are mechanically blocked in the **Open** position.

Visual inspection, through the observation window, will verify whether the internal decoupling mechanism is in the **Coupled** or **Decoupled** position. See Figure 9 on page 16.

- STEP 3.** Padlock the selector handle in either position.



Figure 8. Selector handle operation.

Installation

To couple the switch operator to the switch:

- STEP 1.** Manually operate the switch operator to bring it to the same **Open** or **Closed** position as the Alduti-Rupter Switch. The SWITCH OPERATOR POSITION indicator, seen through the observation window, will show when the approximate **Open** or **Closed** position has been attained. See Figure 9. (The position indicator for the Alduti-Rupter Switch, located on the output-shaft collar of the switch operator, will be aligned later.)
- STEP 2.** Turn the manual operating handle slowly until the position-indexing drums are numerically aligned to move the switch operator to the exact position for coupling.
- STEP 3.** Swing the selector handle upright and rotate it counterclockwise to the **Coupled** position.
- STEP 4.** Lower the handle to engage the locking tab. The selector handle is now in the **Coupled** position.

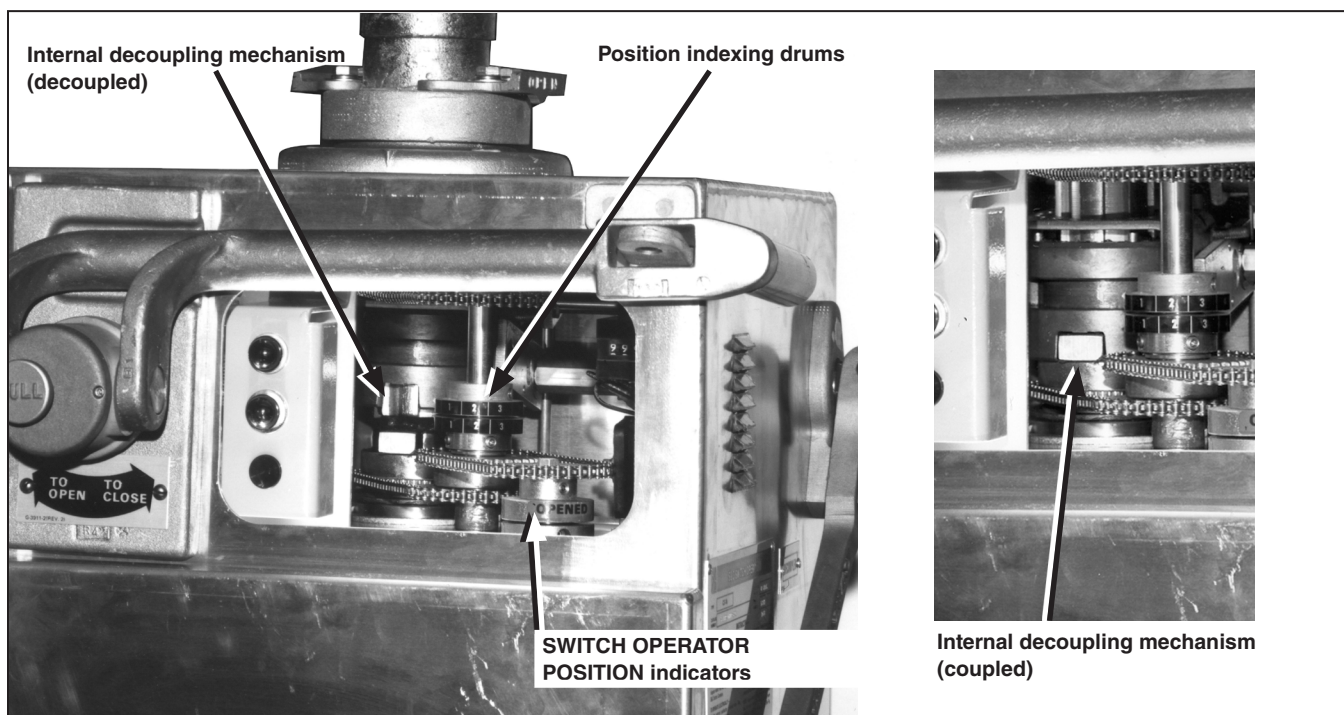

Figure 9. Views of the switch operator through the observation window.

Adjusting the Position Indicator and Cranking Direction

NOTICE

To avoid accidental energizing of the operator after the external connections have been completed, remove the two-pole pull-out fuse holders for the motor and space heater. See Figure 3 on page 10 and Figure 4 on page 11. Reinsert the fuse holders only when indicated in the steps that follow.

Complete the following steps to adjust the position and cranking direction of the switch operator:

- STEP 1.** Verify the main contacts on all three switch poles are fully closed and, where applicable, the switch toggle mechanisms are in an **Over-toggle** position against their respective closed stops. Refer to the instruction sheet furnished with the Alduti-Rupter Switch.
- STEP 2.** With the selector handle in the **Coupled** position, manually crank the switch operator to the fully **Closed** position, as indicated by the SWITCH OPERATOR POSITION indicator. See Figure 2 on page 9.
- STEP 3.** At the switch operator output shaft, replace the detachable portion of the coupling clamp. Verify the cutting tips of the piercing set screws do not protrude through the body of the coupling.
- Torque the flexible coupling clamp bolts equally to final tightness so the clamp pulls down evenly on the vertical-operating-pipe section. Then, tighten the associated piercing set screws, piercing the pipe, and continue turning until feeling a firm resistance. See Figure 10.
- STEP 4.** With the selector handle in the **Coupled** position, crank the Alduti-Rupter Switch to the fully **Open** position, and then to the fully **Closed** position, and in each position accurately align the SWITCH POSITION indicators on the output shaft collar of the switch operator with the alignment arrow below. See Figure 11 on page 18.

Each Alduti-Rupter Switch position indicator can be shifted after loosening the hexhead screws that fasten it to the output-shaft collar. Tighten these screws after making the above alignments.

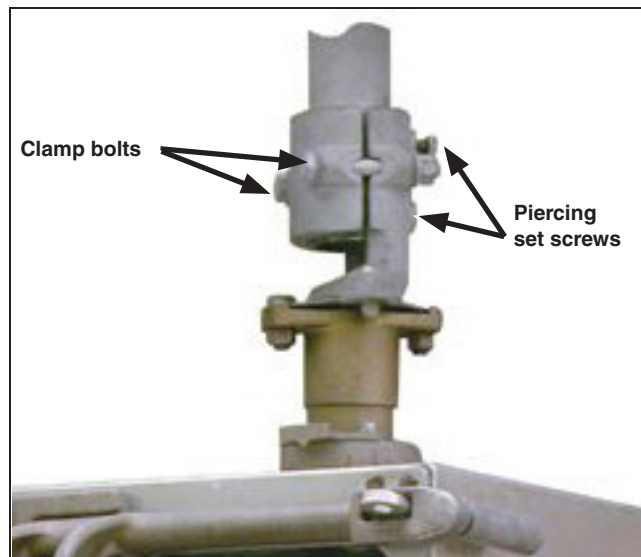

Figure 10. Tighten the clamp bolts and piercing set screws.

For Type AS-1A Switch Operators furnished with source-transfer control compatibility (suffix “-U1”): Omit Step 5 (below) through the “Realigning the Switch Operator Position Indicators” section on page 22 and instead follow the step-by-step procedure outlined in the Appendix on page 27. Continue with the “Adjusting the Auxiliary Switches” section on page 25 when the steps in the Appendix are complete.

STEP 5. The cranking direction to close the Alduti-Rupter Switch is indicated by an arrow plate located near the hub of the manual operating handle. See Figure 3 on page 10. This direction is normally predetermined from the erection drawing for the specific installation and factory-set accordingly. The direction of rotation of the switch operator motor is also normally set at the factory.

- (a) Should the cranking direction required to close the Alduti-Rupter Switch be the opposite to that indicated by the arrow plate, remove the arrow plate, exposing its opposite side. (The direction of motor rotation will be checked in Step 6.)
- (b) Temporarily mark on the top of the switch operator enclosure the direction in which the output shaft rotates to close the Alduti-Rupter Switch. See Figure 11.
- (c) Place the selector handle in the **Decoupled** position in preparation for electrical operation.

STEP 6. With the manual operating handle in its **Storage** position and the selector handle in the **Decoupled** position, reinsert the motor-circuit fuse holder. Open the pushbutton protective cover● and operate the switch operator by means of the externally mounted OPEN/CLOSE buttons, if provided, or, in their absence, by momentarily jumpering terminals 1 and 8 to open and 1 and 9 to close.■

Note the direction in which the travel-limit cams rotate when the switch operator closes. This direction should agree with the temporary direction mark previously made on the top of the enclosure. (As a matter of information, the direction of rotation of the travel-limit cams is always the same as the direction of rotation of the output shaft.)

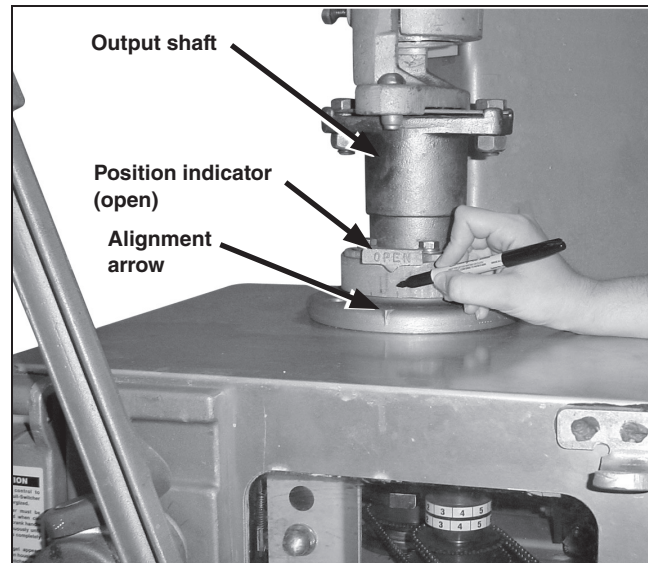

Figure 11. Adjust the position indicator. Mark the direction of operator rotation.

● For switch operators with the optional remote-control blocking switch (suffix “-Y”), opening the pushbutton protective cover prevents remote operation of the switch operator.

■ Terminal designations may differ in special wiring diagrams. In such cases, refer to the specific wiring diagram for the correct terminal designations.

- (a) Should the direction of rotation of the travel-limit cams (as noted above) be the opposite to the temporary direction mark previously made on the top of the enclosure, a reversal of the motor direction will be necessary. Remove the motor-circuit fuse holder to avoid accidental or remote energization of the control circuit.

Interchange the "S1" and "S2" motor leads connected to terminals 4 and 5 on the terminal block in the switch operator enclosure. (On 12-Vdc switch operators, interchange the "S1" and "S2" motor leads connected to the motor terminals.)

- (b) Reversal of the motor direction reverses only the direction of rotation of the output shaft and travel-limit cams. The identity of the opening-stroke and closing-stroke travel-limit cams (which will be adjusted later) will remain unaffected.

Adjusting the Travel-Limit Discs After Motor Direction Reversal

All travel-limit discs in the switch operator are adjusted using the same technique. Skip this section if reversal of the motor is unnecessary. These cams require adjusting only in the event that reversal of the motor was required as described in Step 6 on page 18.

The travel-limit switch (coupled to the motor), which governs the extent of output-shaft rotation in the opening and closing directions, includes two contacts operated by cam-actuated rollers. See Figure 12 on page 20. The cams (upper one is the opening-stroke travel-limit cam, and the one immediately below it is the closing-stroke travel-limit cam) are individually adjustable in 4.5-degree increments.

Therefore, each cam can be adjusted to advance or delay engagement with its roller and thus open or close the corresponding switch contact, as desired, during motor operation. Advancing a cam advances roller engagement to de-energize the corresponding motor contactor earlier and thus decreases the extent of output-shaft rotation.

Conversely, delaying a cam delays engagement with its roller to delay de-energization of the corresponding motor contactor and thus increases the extent of output-shaft rotation.

Adjusting the Closing-Stroke Travel-Limit Discs

STEP 1. Place the selector handle in the **Coupled** position. Manually operate the switch operator in the closing direction and observe the closing-stroke travel-limit cam.

At the completion of the switch operator closing stroke, the leading edge of the closing-stroke travel-limit cam should be engaged with its associated roller. If the leading edge is not engaged with its roller, adjust the closing-stroke travel-limit cam (as follows) so its leading edge touches (or nearly touches) the roller.

- Raise (or lower) the cam toward its adjacent spring until the cam is separated from the teeth of the inner gear.
- Rotate the cam to advance or delay engagement with its roller. See Figure 12 on page 20. Advance the cam to decrease travel. Delay the cam to increase travel.
- Lower (or raise) the cam, verifying the teeth are in mesh with the inner gear.

STEP 2. Remove the motor-circuit fuse holder.

Adjusting the Opening-Stroke Travel-Limit Discs

STEP 1. Place the selector handle in the **Coupled** position. Manually operate the switch operator in the opening direction and observe the opening-stroke travel-limit cam. At the completion of the switch operator opening stroke, the leading edge of the opening-stroke travel-limit cam should be engaged with its roller.

If the leading edge is not engaged with its roller, adjust the opening-stroke travel-limit cam (as described in the section titled *Adjusting the Opening-Stroke Travel-Limit Cam* on page 21) so its leading edge touches (or nearly touches) the roller. Return the manual operating handle to its **Storage** position.

- Raise (or lower) the cam toward its adjacent spring until the cam is separated from the teeth of the inner gear.
- Rotate the cam to advance or delay engagement with its roller. See Figure 12 on page 20. Advance the cam to decrease travel. Delay the cam to increase travel.
- Lower (or raise) the cam, verifying the teeth are in mesh with the inner gear.

STEP 2. Remove the motor-circuit fuse holder.

Installation

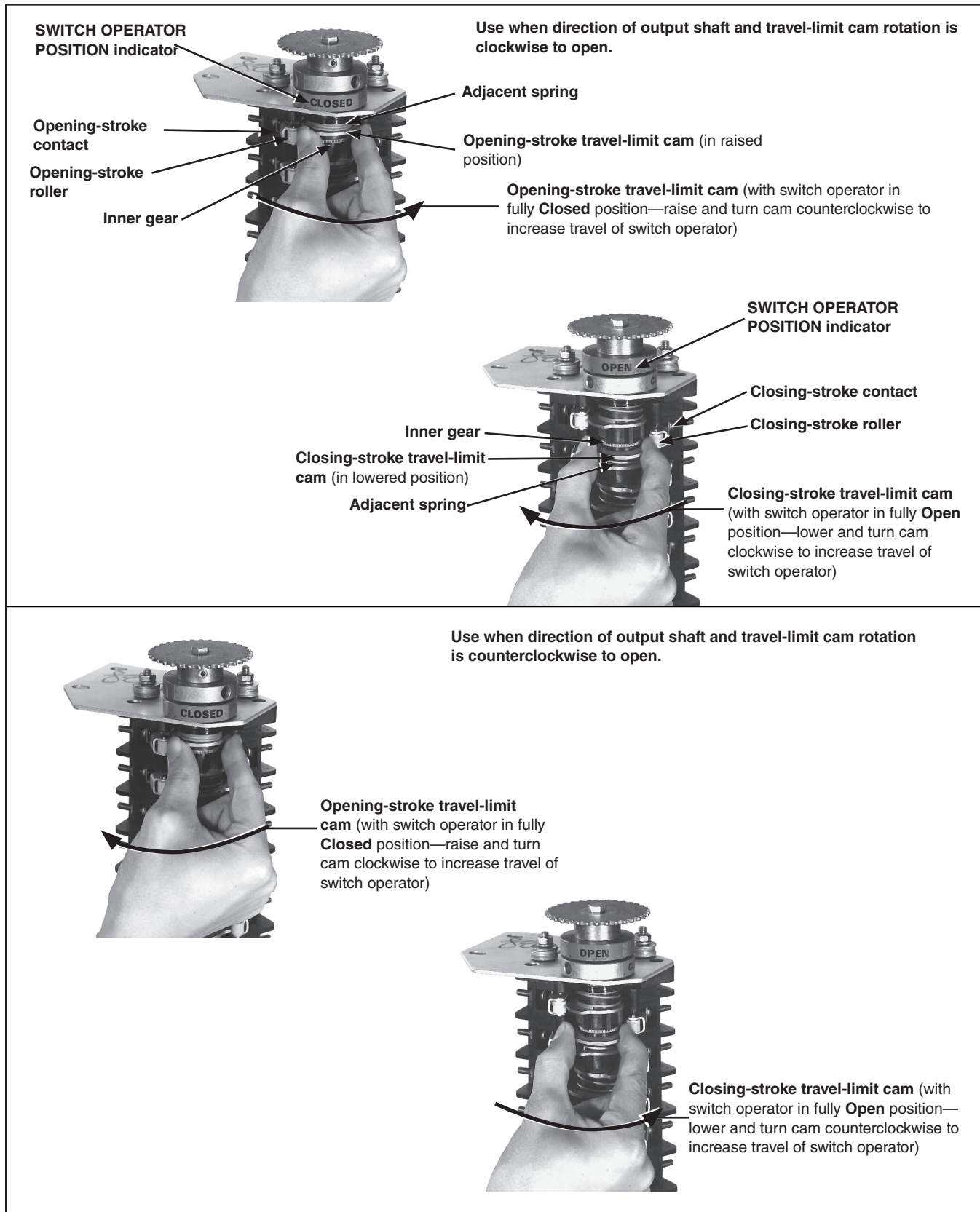

Figure 12. Adjustment of the travel-limit cams.

Intermediate Adjustment of Travel-Limit Discs

The adjustments described in this section are required to obtain a close approximation of the correct travel of the switch operator in the **Decoupled** position—i.e., in a no-load condition, to avoid inadvertently overdriving the Alduti-Rupter Switch when the switch operator is first used for power opening or closing of the switch.

Adjusting the Closing-Stroke Travel-Limit Cam

- STEP 1.** With the selector handle in the **Coupled** position, manually crank the Alduti-Rupter Switch to its fully **Closed** position.
- STEP 2.** Return the manual operating handle to its **Storage** position.
- STEP 3.** Place the selector handle in the decoupled position and replace the motor-circuit fuse holder.
- STEP 4.** Operate the switch operator electronically to open, and then to close. If the position-indexing drums are not numerically aligned, operate the switch operator electronically to open.
- STEP 5.** Remove the motor-circuit fuse holder. Then adjust the closing-stroke travel-limit cam, as described in the “Adjusting the Travel-Limit Discs After Motor Direction Reversal” section on page 19 the necessary number of increments to attain numerical alignment of the position-indexing drums at the completion of a switch operator closing stroke.

Adjusting the Opening-Stroke Travel-Limit Cam

- STEP 1.** With the selector handle in the **Coupled** position, manually crank the Alduti-Rupter Switch to its fully **Open** position.
- STEP 2.** Return the manual operating handle to its **Storage** position.
- STEP 3.** Place the selector handle in the **Decoupled** position and replace the motor-circuit fuse holder.
- STEP 4.** Operate the switch operator electronically to close, and then to open. If the position-indexing drums are not numerically aligned, operate the switch operator electronically to close.

- STEP 5.** Remove the motor-circuit fuse holder. Then, adjust the opening-stroke travel-limit cam, as described in the “Adjusting the Travel-Limit Discs After Motor Direction Reversal” section on page 19 the necessary number of increments to attain numerical alignment of the position-indexing drums at the completion of a switch operator opening stroke.

Final Adjustment of Travel-Limit Cams

The final adjustments are necessary to ensure complete opening and closing of the Alduti-Rupter Switch. Therefore, examine the open and closed stops of the switch.

Operate the switch operator electronically to open and close the Alduti-Rupter Switch. Observe the toggle mechanisms (if applicable) and the open stops on the switch.

Full opening and closing travel likely will not have been attained. This is because the travel-limit cams were adjusted to limit the extent of output-shaft rotation while the switch operator was in the **Decoupled** position—i.e., in a no-load condition. To attain full stop positions (and over-toggle positions, where applicable) of the Alduti-Rupter Switch, refer to Figure 12 on page 20 adjust the opening- and closing-stroke travel-limit cams.

Adjusting the Closing-Stroke Travel-Limit Cam

- STEP 1.** If full closing of the Alduti-Rupter Switch was not attained, replace the motor-circuit fuse holder and operate the switch operator electronically to open the Alduti-Rupter Switch. Remove the motor-circuit fuse holder.
- STEP 2.** To increase travel in the closing direction, delay the closing-stroke travel-limit cam one 4.5-degree increment:
- In the clockwise direction if the travel-limit cam and output shaft rotate clockwise to open the Alduti-Rupter Switch, or
 - In the counterclockwise direction if the travel-limit cam and output shaft rotate counterclockwise to open the Alduti-Rupter Switch
- STEP 3.** Replace the motor-circuit fuse holder and operate the switch operator electronically to close. If full closing travel has not been attained, repeat the procedure described above until full closing travel is attained.

Adjusting the Opening-Stroke Travel-Limit Cam

- STEP 1.** If full opening of the Alduti-Rupter Switch was not attained, operate the switch operator electronically to close the switch. Remove the motor-circuit fuse holder.
- STEP 2.** To increase travel in the opening direction, limit the opening-stroke travel-limit cam one 4.5-degree increment:
- (a) In the counterclockwise direction if the travel-limit cam and output shaft rotate clockwise to open the Alduti-Rupter Switch, or
 - (b) In the clockwise direction if the travel-limit cam and output shaft rotate counterclockwise to open the Alduti-Rupter Switch.
- STEP 3.** Replace the motor-circuit fuse holder and operate the switch operator electronically to open. If full opening travel has not been attained, repeat the procedure described above until full opening travel is attained.

Realigning the SWITCH OPERATOR

POSITION Indicators

When travel-limit cam adjustments have been completed, it may be necessary to realign the Alduti-Rupter Switch position indicators on the switch operator output-shaft collar with the alignment arrow.

- STEP 1.** With the switch operator in the fully **Open** position and then in the fully **Closed** position, check the corresponding SWITCH OPERATOR POSITION indicator. In each position, the corresponding position indicator should be readily visible from the front of the enclosure.
- STEP 2.** If adjustment of either position indicator is necessary, remove the motor-circuit fuse holder, loosen the two set screws on the position indicator, and rotate the position indicator to the desired position. Retighten the set screws. See Figure 11 on page 18.

Adjusting the Auxiliary Switches

The auxiliary switch, which is permanently coupled to the motor, includes eight contacts (terminals 11 through 26). If the optional position-indicating lamps are included, six contacts are available (terminals 13 through 18 and 21 through 26). These contacts are provided so external circuits can be established to monitor switching operations. Each contact is operated by a cam-actuated roller. The cams are individually adjustable in 4.5-degree increments. Adjustment of the cams is accomplished in a manner identical to the description in “Adjusting the Travel-Limit Discs After Motor Direction Reversal” section on page 19 for the travel-limit cams.

The “standard” configuration for the auxiliary switch consists of four “a1” contacts (terminals 11 through 18) and four “b1” contacts (terminals 19 through 26). Thus, with the switch operator in the **Open** position, the “a1” contacts are open and the “b1” contacts are closed.

Conversely, with the switch operator in the **Closed** position, the “a1” contacts are closed and the “b1” contacts are open. A contact is closed if its roller is disengaged from a cam and, conversely, a contact is open if its roller is engaged by a cam. See Figure 13 and Figure 14 on page 24.

Any auxiliary-switch contact being used must be checked for proper operation after the switch operator travel-limit cams have been adjusted. Check the auxiliary switch contacts for both the **Open** and **Closed** positions of the Alduti-Rupter Switch.

If necessary, adjust the cams as described in “Adjusting the Travel-Limit Discs After Motor Direction Reversal” section on page 19 so the auxiliary-switch contacts are in the desired **Open** or **Closed** position (i.e., the cam engaged with the roller, or the cam disengaged from the roller). See Figure 14 on page 24.

Because each cam can be individually adjusted in 4.5-degree increments, any “a1” contact can be changed to a “b1” contact, or vice versa. Also, because of the many positions to which the cams can be adjusted, the various rollers can be engaged or disengaged to respectively open or close their contacts simultaneously, sequentially, randomly, or in various combinations.

Adjustment of the auxiliary-switch contacts for other than the “standard” configuration is left to the user. The motor circuit fuse holder should be removed when adjusting these contacts. (Switch operators having catalog numbers with the suffix “-Q” are equipped with an extra auxiliary switch, terminals 27 through 34, having four contacts—two “a1” and two “b1”—that may be adjusted as described in the “Adjusting the Travel-Limit Discs After Motor Direction Reversal” section on page 19). See Figure 13 and Figure 14 on page 24.

Reinsert the fuse holders for the motor circuit and space heater circuit after making any adjustments.

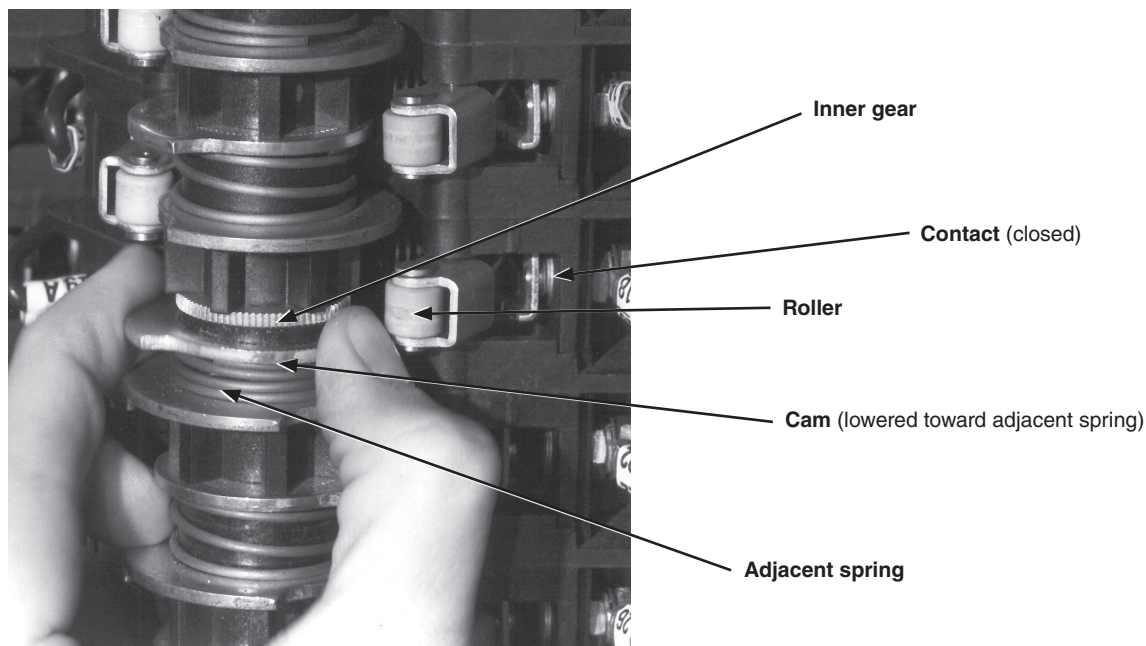

Figure 13. Adjustment of cams on auxiliary switch.

Installation

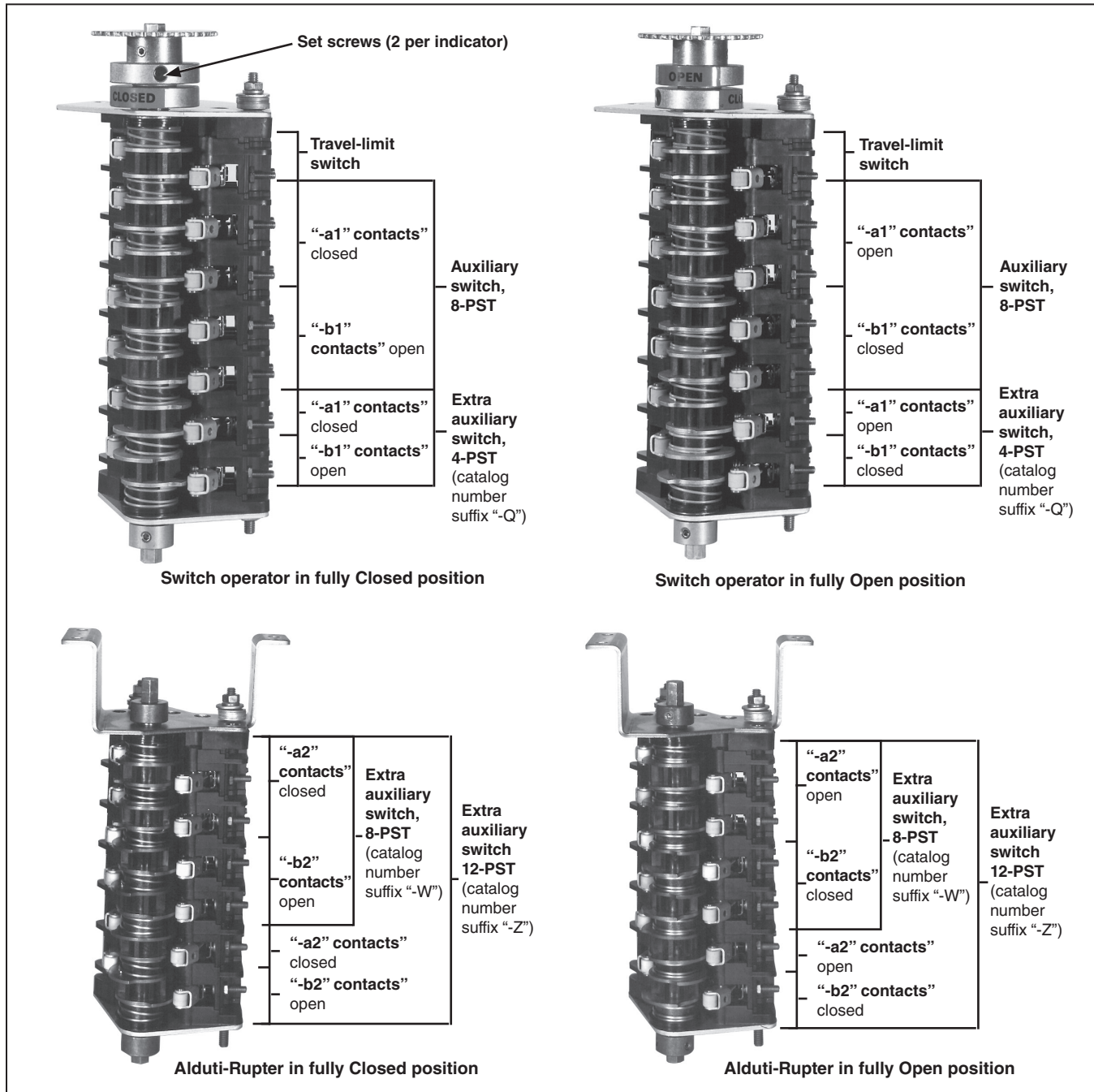

Figure 14. Standard contact configurations.

Adjusting the Extra Auxiliary Switches

Switch operators having catalog numbers with either the suffix “-W” or “-Z” are equipped with an extra auxiliary switch permanently coupled to the Alduti-Rupter Switch. The suffix “-W” auxiliary switch consists of eight contacts (terminals 35 through 50). The suffix “-Z” auxiliary switch consists of 12 contacts (terminals 35 through 50 plus terminals 80 through 87). These contacts are provided so external circuits can be established to monitor Alduti-Rupter Switch operation. Each contact is operated by a cam-actuated roller, and the cams are individually adjustable in 4.5-degree increments.

The “standard” configuration for the suffix “-W” extra auxiliary switch consists of four “a2” contacts (terminals 35 through 42) and four “b2” contacts (terminals 43 through 50). The “standard” configuration for the suffix “-Z” extra auxiliary switch consists of six “a2” contacts (terminals 35 through 42 and terminals 80 through 83) and six “b2” contacts (terminals 43 through 50 and terminals 84 through 87).

Thus, with the Alduti-Rupter Switch in the fully **Closed** position, the “a2” contacts should be closed and the “b2” contacts should be open. Conversely, with the Alduti-Rupter Switch in the fully **Open** position, the “a2” contacts should be open and the “b2” contacts should be closed.

Any suffix “-W” or “-Z” auxiliary-switch contact being used must be checked for proper operation after satisfactory electrical operation of the Alduti-Rupter Switch has been achieved. Check the auxiliary-switch contact engagement for both the **Open** and **Closed** positions of the Alduti-Rupter Switch. Adjustment of the suffix “-W” or “-Z” extra auxiliary switch is identical to the adjustment

performed for the travel-limit switch, the auxiliary switch, and the suffix “-Q” extra auxiliary switch.

Therefore, if adjustment of the suffix “-W” or “-Z” auxiliary switch is needed, refer to in the “Adjusting the Travel-Limit Discs After Motor Direction Reversal” section on page 19). See Figure 13 on page 23 and Figure 14 on page 24.

Reinsert the fuse holders for the motor circuit and space heater circuit after making any adjustments.

Checking Switch Operator and Alduti-Rupter Switch Positions Before Energization

Do not assume the switch operator position necessarily indicates the **Open** or **Closed** position of the Alduti-Rupter Switch. Upon completion of an opening or closing operation (electrical or manual), make sure the following conditions exist:

- The SWITCH OPERATOR POSITION indicator, Figure 9 on page 16, signals “OPEN” or “CLOSED” to indicate the switch operator has moved through a complete operation. Also note the POSITION INDICATING lamps, Figure 4 on page 11, if furnished.
- The Alduti-Rupter Switch position indicator, located on the switch operator output shaft, Figure 2 on page 9, is in agreement with the SWITCH OPERATOR POSITION indicator. That is, both indicators should simultaneously show “OPEN” or “CLOSED.”
- The blades on all three poles of the Alduti-Rupter Switch are fully open or fully closed (by visual verification).

Then, tag and padlock the switch operator in accordance with standard system operating procedures. In all cases, make sure the switch operator is padlocked before “walking away.”

Final Checks Before Walking Away

To ensure the switch operator is ready for normal power operation of the Alduti-Rupter Switch by remote automatic or supervisory control, make sure the following conditions exist:

- The selector handle is in the **Coupled** position.
- The manual operating handle is in its **Storage** position.
- The two-pole pull-out fuse holders for the motor circuit and space-heater circuit are inserted.
- The pushbutton protective cover is closed.
- The switch operator is tagged and padlocked in accordance with standard system operating procedures.

For Type AS-1A Switch Operators Furnished With Source-Transfer Control Compatibility (Suffix “-U1”)

Follow the step-by-step procedure outlined below after having completed Step 4 on page 17.

STEP 1. The cranking direction to close the Alduti-Rupter Switch is indicated by an arrow plate located near the hub of the manual operating handle. See Figure 3 on page 10. This direction has been predetermined from the erection drawing for the specific installation and has been factory-set accordingly. The direction of rotation of the switch operator motor has also been set at the factory. Verify these directions of rotation are correct as follows:

- (a) With the selector handle in the **Coupled** position, manually crank the Alduti-Rupter Switch to the fully **Open** position and then to the fully **Closed** position. Temporarily mark on the top of the switch operator enclosure the direction in which the output shaft rotates to close the Alduti-Rupter Switch.
- (b) If the cranking direction required to close the Alduti-Rupter Switch is opposite to that indicated by the arrow plate, remove the arrow plate mounting screws and remount the arrow plate, exposing the opposite side.
- (c) With the manual operating handle in its **Storage** position and the selector handle in the **Decoupled** position, reinsert the motor-circuit fuse holder. Open the pushbutton protective cover and operate the switch operator by means of the externally mounted OPEN/CLOSE buttons, if provided, or in their absence, by momentarily jumpering terminals 1 and 8 to open, and 1 and 9 to close.●

Note the direction in which the travel limit discs rotate when the switch operator closes. The direction should agree with the temporary direction mark previously made on the top of the enclosure and with

the direction displayed in the cutaway section on the outer ring of the travel-limit discs. See Figure 15 on page 28. (The direction of rotation of the travel-limit discs is always the same as the direction of rotation of the output shaft.)

- (d) Should the direction of rotation of the travel-limit discs noted in Step 1(c) be the opposite to the temporary direction mark previously made in Step 1(a), a reversal of the motor direction will be necessary. Remove the motor-circuit fuse holder to avoid accidental or remote energization of the control circuit. Interchange the “S1” and “S2” motor leads connected to terminals 4 and 5 on the terminal block in the switch operator enclosure.

Note: Reversal of the motor direction reverses only the direction of rotation of the output shaft and travel-limit discs. The identity of the opening-stroke and closing-stroke travel-limit discs (which will be adjusted later) will remain unaffected.

- (e) Should the direction of rotation of the travel-limit discs noted in Step 1(c) be the opposite to the direction displayed in the cutaway section on the outer ring of the closing-stroke travel-limit disc, remove the positioning screws on the outer ring of the closing-stroke travel-limit disc. See Figure 15 on page 28. Rotate the outer ring until the desired direction is displayed in the cutaway section. Replace the positioning screws.
- (f) Reinsert the motor-circuit fuse holder and operate the switch operator to the **Open** position.
- (g) If the direction of output-shaft rotation to open the Alduti-Rupter Switch is opposite to that displayed in the cutaway section on the outer ring of the opening stroke travel-limit disc, change the direction displayed as indicated in Step 1(e).

● Terminal designations may differ in special wiring diagrams. In such cases, refer to the specific wiring diagram for the correct terminal designations.

STEP 2. The travel-limit switch (coupled to the motor) that governs the extent of output-shaft rotation in the opening and closing directions includes six contacts that are operated by cam-actuated rollers. Positioning of the cams to properly engage the rollers is facilitated by the travel-limit discs (upper one is the opening-stroke travel-limit disc; lower one is the closing-stroke travel-limit disc). Adjustment of the opening-stroke travel-limit disc (and therefore the associated cams) is accomplished as follows:

- (a) Remove the motor-circuit fuse holder.
- (b) Place the selector handle in the **Coupled** position and manually crank the Alduti-Rupter Switch to the fully **Open** position.
- (c) Grasp the handwheel and turn it to the extent possible in a direction opposite to the direction the output shaft rotates to open the Alduti-Rupter Switch. See Figure 15.

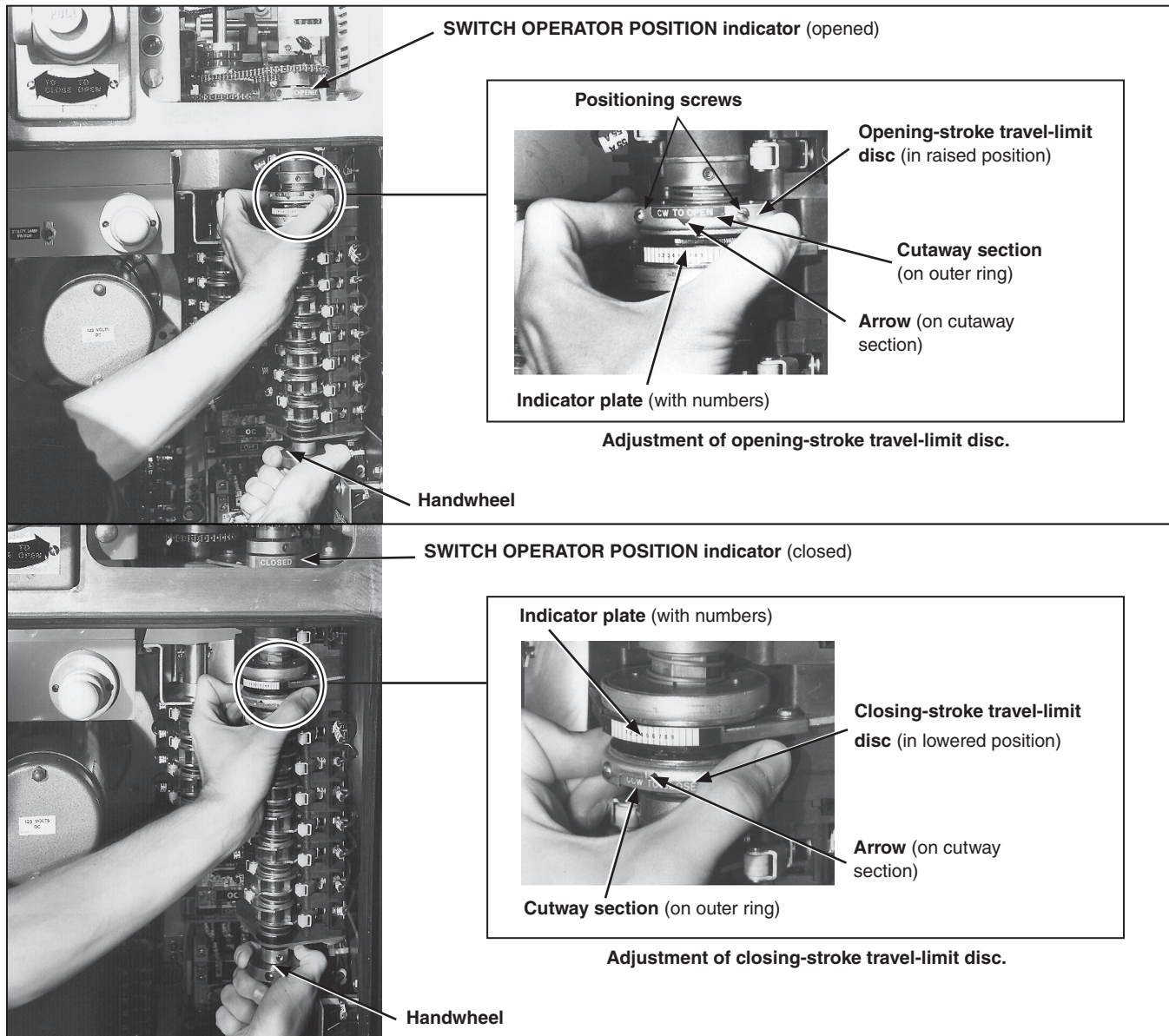

Figure 15. Adjustment of travel-limit discs.

- (d) With the handwheel held in the position indicated above, raise the opening-stroke travel-limit disc approximately $\frac{3}{16}$ -inch (5 mm) and rotate the disc until the arrow on its outer ring is in line with the number 5 on the indicator plate. Lower the disc, verify it is engaged, and release the handwheel.

STEP 3. Adjustment of the closing-stroke travel-limit disc (and therefore the associated cams) is accomplished as follows:

- (a) Manually crank the Alduti-Rupter Switch to the fully **Closed** position.
- (b) Grasp the handwheel and turn it to the extent possible in a direction opposite to the direction the output shaft rotates to close the Alduti-Rupter Switch. See Figure 15 on page 28.
- (c) With the handwheel held in the position indicated above, lower the closing-stroke travel-limit disc approximately $\frac{3}{16}$ -inch (5 mm) and rotate the disc until the arrow on the outer ring is in line with the number 5 on the indicator plate. Raise the disc, verify it is engaged, and release the handwheel.

STEP 4. To preclude the possibility of inadvertently overdriving the Alduti-Rupter Switch when the switch operator is first used for power opening of the switch:

- (a) With the selector handle in the **Coupled** position, manually crank the Alduti-Rupter Switch to the fully **Open** position.
- (b) Place the selector handle in the **Decoupled** position.
- (c) Return the manual operating handle to its **Storage** position.
- (d) Reinsert the motor-circuit fuse holder.
- (e) Operate the switch operator electronically to close and then to open. If the position-indexing drums are not numerically aligned, operate the switch operator electronically to close. Then, adjust the opening-stroke travel-limit disc, as described in Step 2 on page 28, to attain numerical alignment of the position-indexing drums at the completion of a switch operator opening stroke.
- (f) Remove the motor-circuit fuse holder.

STEP 5. To preclude the possibility of inadvertently overdriving the Alduti-Rupter Switch when the switch operator is first used for power closing of the switch:

- (a) With the selector handle in the **Coupled** position, manually crank the Alduti-Rupter Switch to the fully **Closed** position.
- (b) Place the selector handle in the **Decoupled** position.
- (c) Return the manual operating handle to its **Storage** position.
- (d) Reinsert the motor-circuit fuse holder.
- (e) Operate the switch operator electronically to open and then to close. If the position-indexing drums are not numerically aligned, operate the switch operator electronically to open. Remove the motor-circuit fuse holder. Then, adjust the closing-stroke travel-limit disc, as described in Step 3, to attain numerical alignment of the position-indexing drums at the completion of a switch operator closing stroke.

STEP 6. Place the selector handle in the **Coupled** position. Operate the switch operator electronically to open and to close the Alduti-Rupter Switch.

Observe the toggle mechanisms (if applicable) and the open stops on the switch. Full opening and closing travel likely will not have been attained because the travel-limit discs were adjusted to limit the extent of output-shaft rotation while the switch operator was in the **Decoupled** position—i.e., a no-load condition. To attain full **Stop** positions (and **Overtoggle** positions, where applicable), perform the following:

- (a) If full opening of the Alduti-Rupter Switch was not attained, replace the motor-circuit fuse holder and operate the switch operator electronically to close the Alduti-Rupter Switch. Remove the motor-circuit fuse holder.

To increase travel in the opening direction: Limit the opening-stroke travel-limit disc one indicator-plate number. The direction of disc rotation is always the same as that of the output shaft. Repeat this procedure until full opening travel is attained.

- (b) If full closing of the Alduti-Rupter Switch was not attained, replace the motor-circuit fuse holder and operate the switch operator electronically to open the Alduti-Rupter Switch. Remove the motor-circuit fuse holder.

To increase travel in the closing direction: Limit the closing-stroke travel-limit disc one indicator-plate number. The direction of disc rotation is always the same as that of the output shaft. Repeat this procedure until full closing travel is attained.

STEP 7. When travel-limit disc adjustments have been completed, it may be necessary to realign the Alduti-Rupter Switch position indicators on the switch operator output-shaft collar with the alignment arrow. With the switch operator in the fully **Open** position and then the fully **Closed** position, check the corresponding SWITCH OPERATOR POSITION indicator.

In each position, the corresponding position indicator should be readily visible from the front of the enclosure. If adjustment of either position indicator is necessary, remove the motor-circuit fuse holder, loosen the two set screws on the position indicator, and rotate the position indicator to the desired position. Re-tighten the set screws. See Figure 14 on page 24 and Figure 15 on page 28.

Adjust any auxiliary switches or extra auxiliary switches as described in the “Adjusting the Auxiliary Switches” section on page 23 and the “Adjusting the Extra Auxiliary Switches” section on page 25. Then, complete the checks on page 26.