

Field Replacement

Table of Contents

Introduction	2	Safety Precautions	5
Qualified Persons	2	Shipping and Handling	6
Read this Instruction Sheet	2	Packing	6
Retain this Instruction Sheet.	2	Inspection	6
Proper Application	2	Replacing the Operating Mechanism	7
Warranty	2	Preparing the Switch.	7
Safety Information.	3	Removing the Operating Mechanism.	9
Understanding Safety-Alert Messages.	3	Preparing the Replacement	
Following Safety Instructions	3	Operating Mechanism	10
Replacement Instructions and Labels	3	Installing the Replacement	
Location of Safety Labels	4	Operating Mechanism	11

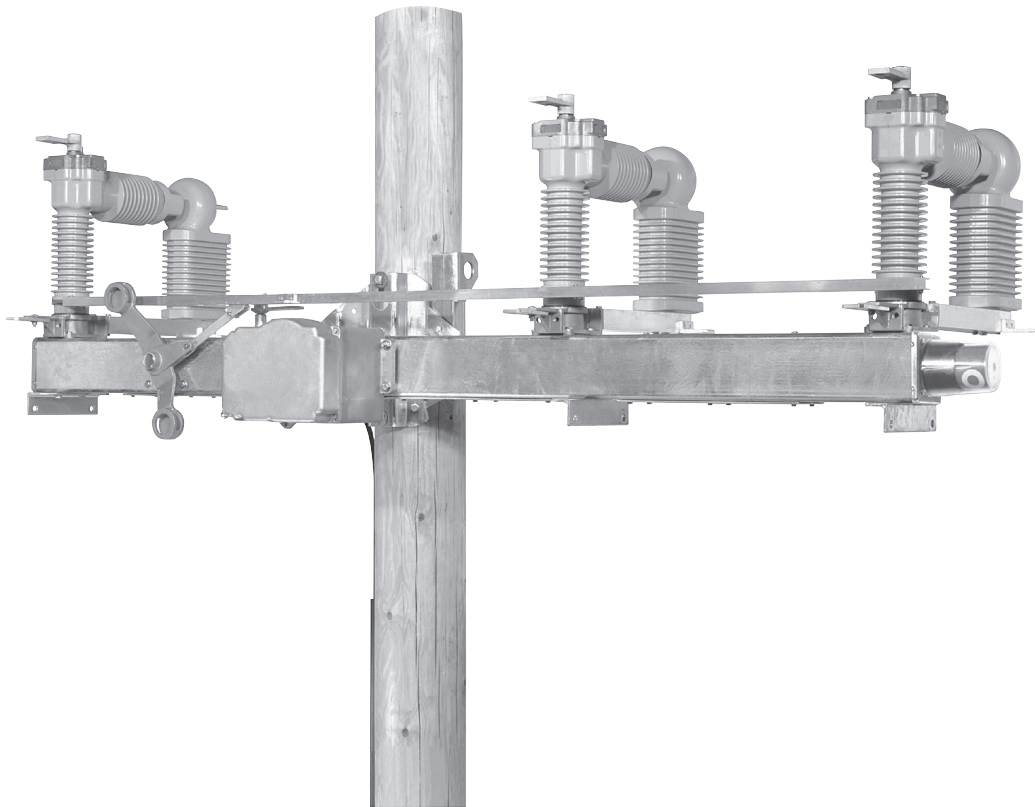

★ This instruction sheet applies to upright, tiered-outboard, and pole-top mounted switches shipped before May 2000, current production vertical mounting configuration, and switches with the optional “-H” catalog number suffix.



Qualified Persons

WARNING

Only qualified persons who are knowledgeable in the installation, operation, and maintenance of overhead and underground electric distribution equipment, along with all associated hazards, may install, operate, and maintain the equipment covered by this publication. A qualified person is someone who is trained and competent in:

- The skills and techniques necessary to distinguish exposed live parts from nonlive parts of electrical equipment
- The skills and techniques necessary to determine the proper approach distances corresponding to the voltages to which the qualified person will be exposed
- The proper use of special precautionary techniques, personal protective equipment, insulated and shielding materials, and insulated tools for working on or near exposed energized parts of electrical equipment

These instructions are intended only for such qualified persons. They are not intended to be a substitute for adequate training and experience in safety procedures for this type of equipment.

Read this Instruction Sheet

NOTICE

Read this instruction sheet thoroughly and carefully before replacing the high-speed operating mechanism on a Scada-Mate Switch. Become familiar with the Safety Information and Safety Precautions on pages 3 through 5. The latest version of this publication is available online in PDF format at sandc.com/en/support/product-literature/.

Retain this Instruction Sheet

This instruction is a permanent part of your Scada-Mate Switching System. Designate a location where users can easily retrieve and refer to this publication.

Proper Application

WARNING

The equipment in this publication is only intended for a specific application. The application must be within the ratings furnished for the equipment. Ratings for Scada-Mate Switching Systems are listed in the ratings table in Specification Bulletin 768-31. The ratings are also on the nameplate affixed to the product.

Warranty

The warranty and/or obligations described in S&C's Price Sheet 150, "Standard Conditions of Sale—Immediate Purchasers in the United States," (or Price Sheet 153, "Standard Conditions of Sale—Immediate Purchasers Outside the United States"), plus any special warranty provisions, as set forth in the applicable product-line specification bulletin, are exclusive. The remedies provided in the former for breach of these warranties shall constitute the immediate purchaser's or end user's exclusive remedy and a fulfillment of the seller's entire liability. In no event shall the seller's liability to the immediate purchaser or end user exceed the price of the specific product that gives rise to the immediate purchaser's or end user's claim. All other warranties, whether express or implied or arising by operation of law, course of dealing, usage of trade or otherwise, are excluded. The only warranties are those stated in Price Sheet 150 (or Price Sheet 153), and THERE ARE NO EXPRESS OR IMPLIED WARRANTIES OF MERCHANTABILITY OR FITNESS FOR A PARTICULAR PURPOSE. ANY EXPRESS WARRANTY OR OTHER OBLIGATION PROVIDED IN PRICE SHEET 150 (OR PRICE SHEET 153) IS GRANTED ONLY TO THE IMMEDIATE PURCHASER AND END USER, AS DEFINED THEREIN. OTHER THAN AN END USER, NO REMOTE PURCHASER MAY RELY ON ANY AFFIRMATION OF FACT OR PROMISE THAT RELATES TO THE GOODS DESCRIBED HEREIN, ANY DESCRIPTION THAT RELATES TO THE GOODS, OR ANY REMEDIAL PROMISE INCLUDED IN PRICE SHEET 150 (OR PRICE SHEET 153).

Understanding Safety-Alert Messages

Several types of safety-alert messages may appear throughout this instruction sheet and on labels and tags attached to the Scada-Mate Switching System. Become familiar with these types of messages and the importance of these various signal words:

⚠ DANGER

“DANGER” identifies the most serious and immediate hazards that will likely result in serious personal injury or death if instructions, including recommended precautions, are not followed.

⚠ WARNING

“WARNING” identifies hazards or unsafe practices that can result in serious personal injury or death if instructions, including recommended precautions, are not followed.

⚠ CAUTION

“CAUTION” identifies hazards or unsafe practices that can result in minor personal injury if instructions, including recommended precautions, are not followed.

NOTICE

“NOTICE” identifies important procedures or requirements that can result in product or property damage if instructions are not followed.

Following Safety Instructions

If any portion of this instruction sheet is unclear and assistance is needed, contact the nearest S&C Sales Office or S&C Authorized Distributor. Their telephone numbers are listed on S&C’s website sandc.com, or call the S&C Global Support and Monitoring Center at 1-888-762-1100.

NOTICE

Read this instruction sheet thoroughly and carefully before installing a Scada-Mate Switching System.



Replacement Instructions and Labels

If additional copies of this instruction sheet are required, contact the nearest S&C Sales Office, S&C Authorized Distributor, S&C Headquarters, or S&C Electric Canada Ltd.

It is important that any missing, damaged, or faded labels on the equipment be replaced immediately. Replacement labels are available by contacting the nearest S&C Sales Office, S&C Authorized Distributor, S&C Headquarters, or S&C Electric Canada Ltd.

Safety Information

Location of Safety Labels

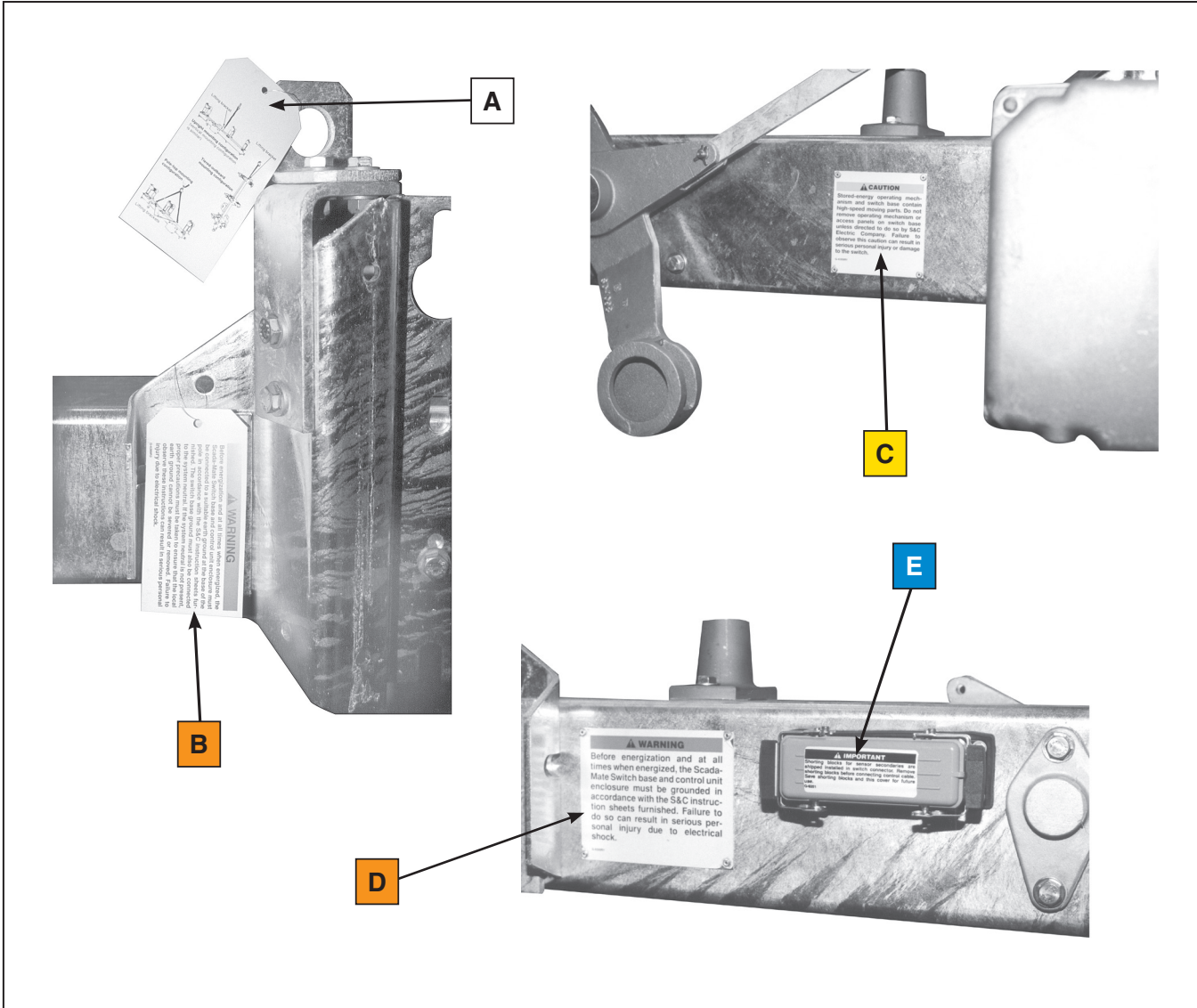

Reorder Information for Safety Labels

Location	Safety Alert Message	Description	Part Number
A	None	Lifting Instructions	G-6252R1●
B	⚠ WARNING	Before energization and at all times when energized, the Scada-Mate switch base and control unit enclosure . . .	G-6289R3●
C	⚠ CAUTION	Stored-energy operating mechanism and switch base . . .	G-6308R1
D	⚠ WARNING	Before energization and at all times when energized, the Scada-Mate switch base and control unit . . .	G-6350R1
E	NOTICE	Shorting blocks for sensor secondaries are shipped installed in switch connector . . .	G-6351

- This is a tag to be removed and discarded after the switch is installed and adjusted.

⚠ DANGER



Scade-Mate Switching Systems operate at high voltage. Failure to observe the precautions below will result in serious personal injury or death.

Some of these precautions may differ from your company's operating procedures and rules. Where a discrepancy exists, follow your company's operating procedures and rules.

- | | |
|--|--|
| <ol style="list-style-type: none"> 1. QUALIFIED PERSONS. Access to switches and controls must be restricted only to qualified persons. See the "Qualified Persons" section on page 2. 2. SAFETY PROCEDURES. Always follow safe operating procedures and rules. 3. PERSONAL PROTECTIVE EQUIPMENT. Always use suitable protective equipment, such as rubber gloves, rubber mats, hard hats, safety glasses, and flash clothing, in accordance with safe operating procedures and rules. 4. SAFETY LABELS. Do not remove or obscure any of the "DANGER," "WARNING," "CAUTION," or "NOTICE" labels. 5. OPERATING MECHANISM AND BASE. Stored-energy operating mechanism and switch base contain fast-moving parts that can severely injure fingers. Do not remove or disassemble the operating mechanism or remove the access panel on the switch base unless directed by S&C Electric Company. 6. ENERGIZED COMPONENTS. Always consider all parts live until de-energized, tested, and grounded. | <ol style="list-style-type: none"> 7. GROUNDING. <ul style="list-style-type: none"> • Before energization and at all times when energized, the switch base and control unit enclosure must be connected to suitable earth ground at the base of pole in accordance with the S&C instruction sheet furnished with this device. • The switch base ground must also be connected to the system neutral. If the system neutral is not present, proper precautions must be taken to ensure that the local earth ground cannot be severed or removed. 8. LOAD-INTERRUPTER SWITCH POSITION. <ul style="list-style-type: none"> • Always confirm the Open/Close position of load-interrupter switches by visually observing the indicator. • Interrupters and terminal pads may be energized from either terminal. • Interrupters and terminal pads may be energized with the interrupters in any position. 9. MAINTAINING PROPER CLEARANCE. Always maintain proper clearance from energized components. |
|--|--|

Shipping and Handling

Packing

The replacement kit will be packaged and crated appropriately to avoid damage during shipment. It will include one replacement operating mechanism with shipping guard. The associated hardware used in the replacement of the operating mechanism will vary with the different mounting configurations

Examine the shipment for external evidence of damage as soon after receipt as possible, preferably before removal from the carrier's conveyance. Check the bill of lading to make sure the listed shipping skids, crates, and containers are present.

Inspection

If there is visible loss and/or damage:

1. Notify the delivering carrier immediately.
2. Ask for a carrier inspection.
3. Note condition of shipment on all copies of the delivery receipt.
4. File a claim with the carrier.

If concealed damage is discovered:

1. Notify the delivering carrier within 15 days of receipt of shipment.
2. Ask for a carrier inspection.
3. File a claim with the carrier.

Also, notify S&C Electric Company in all instances of loss and/or damage.

Preparing the Switch

STEP 1. Place the LOCAL/REMOTE switch on the switch control in the control unit in the **Local** position. After following the user's standard procedures for clearing and tagging equipment on which work is to be performed, open the Scada-Mate Switch interrupter contacts by pressing the OPEN pushbutton in the control unit. Also place the POWER switch on the battery charger in the control unit in the **Off** position.

Remove the short bolt from the blocking-bolt hole on the bottom of the operating mechanism and replace with a $\frac{3}{8}$ -16 \times 1 $\frac{1}{4}$ hexhead stainless steel cap screw (provided with the replacement kit). Tighten the screw until a resistance is felt but do not tighten with a wrench. This "blocking bolt" will prevent inadvertent tripping of the operating mechanism while the switch is being serviced. See Figure 1.

STEP 2.

⚠ WARNING
<p>To prevent serious injury to hands resulting from inadvertent tripping of the mechanism, do not remove the operating mechanism or access panels from the switch unless the blocking bolt is installed on the mechanism.</p>

Remove the access panel(s) on the switch base nearest the mechanism. The access panels are attached to the switch base with $\frac{1}{4}$ -20 \times 1 hex-head stainless steel cap screws and flat washers. Save the access covers and hardware for reuse. See Figure 2.

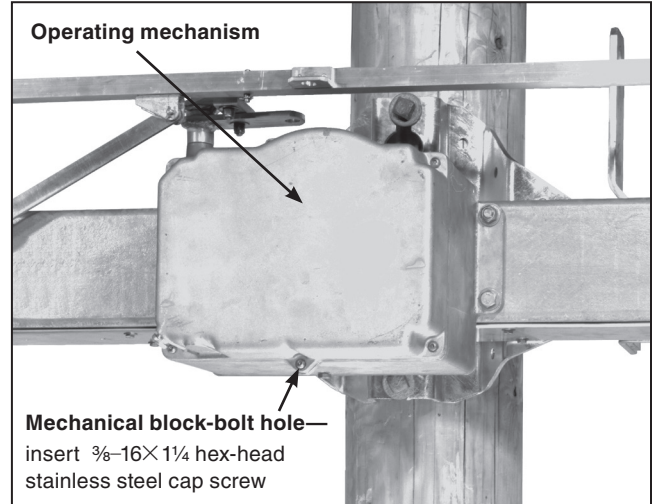

Figure 1. Removing the short bolt and install the blocking bolt.

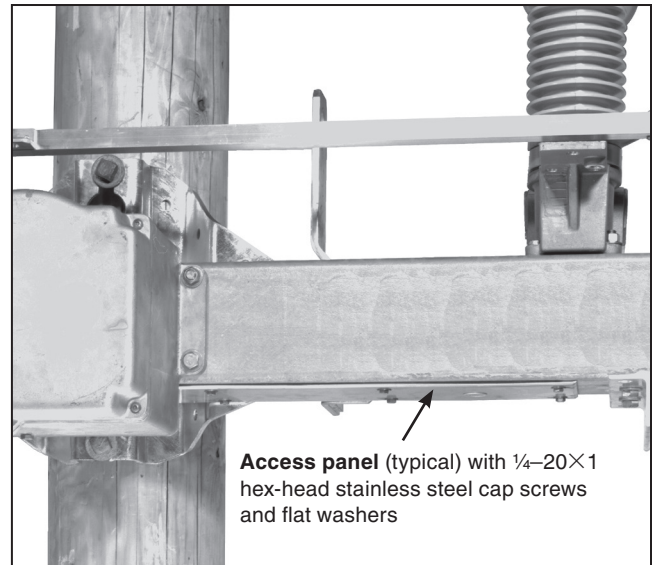

Figure 2. Removing the access panel(s).

Replacing the Operating Mechanism

STEP 3. Remove and discard the $\frac{5}{16}$ -18 elastic nut and flat washer that connects the drive linkage to the connecting stud on the interphase linkage. See Figure 3.

STEP 4. Remove and discard the cotter pin and flat washer that connects the trip linkage to the TRIP lever. Then, disconnect the circular plastic connector that connects the wiring harness to back of the mechanism by pinching the connector and pulling it off. See Figure 4.

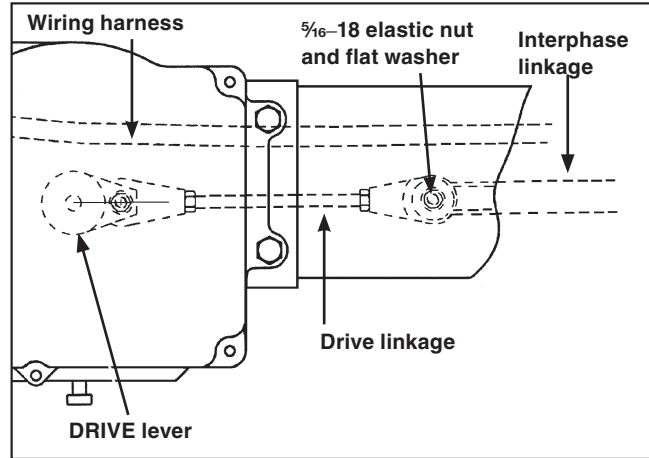

Figure 3. Disconnecting the interphase linkage.

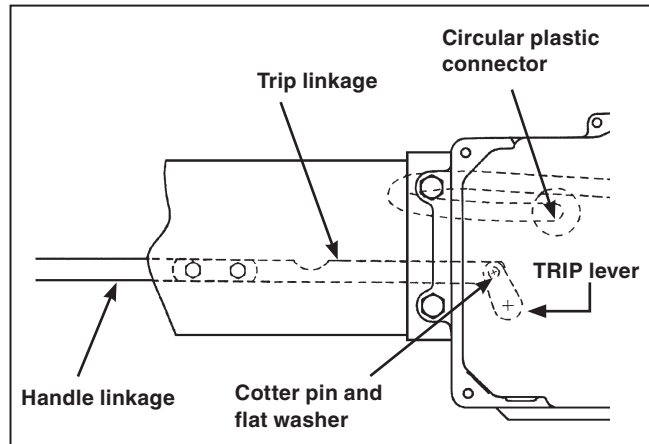

Figure 4. Disconnecting the trip linkage.

Removing the Operating Mechanism

STEP 5. Remove the two $\frac{1}{2}$ -13 \times 1 $\frac{1}{2}$ hex-head stainless steel cap screws and flat washers that attach the mechanism to the switch base. Save the cap screws for reuse. Then, remove and discard the two $\frac{1}{2}$ -13 hex nuts and flat washers that also attach the mechanism to the switch base. Slowly remove the mechanism from the switch base, taking care not to damage the drive linkage still connected to the mechanism. See Figure 5.

STEP 6. Remove and discard the $\frac{3}{8}$ -16 elastic nut and flat washer that connects the drive linkage to the DRIVE lever on the existing operating mechanism. Also remove and discard the $\frac{1}{4}$ -20 \times $\frac{1}{4}$ socket-head set screw used to secure the DRIVE lever to the mechanism. A propane torch should first be applied to the set screw to loosen the red Loctite® threadlocker holding the set screw in place. Save the DRIVE lever and drive linkage for reuse. See Figure 6.

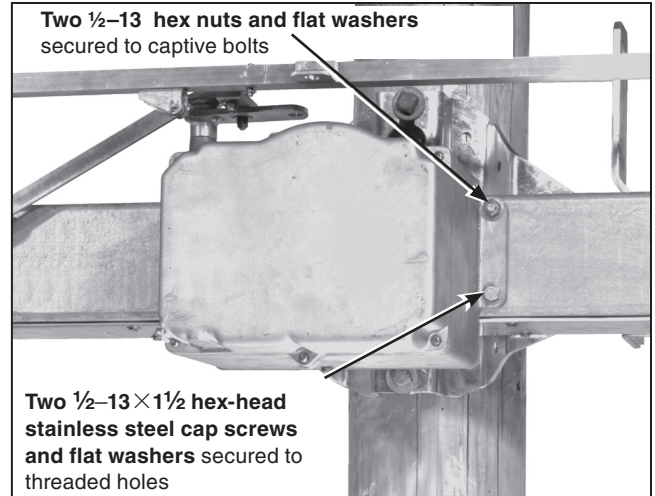

Figure 5. Removing the operating mechanism.

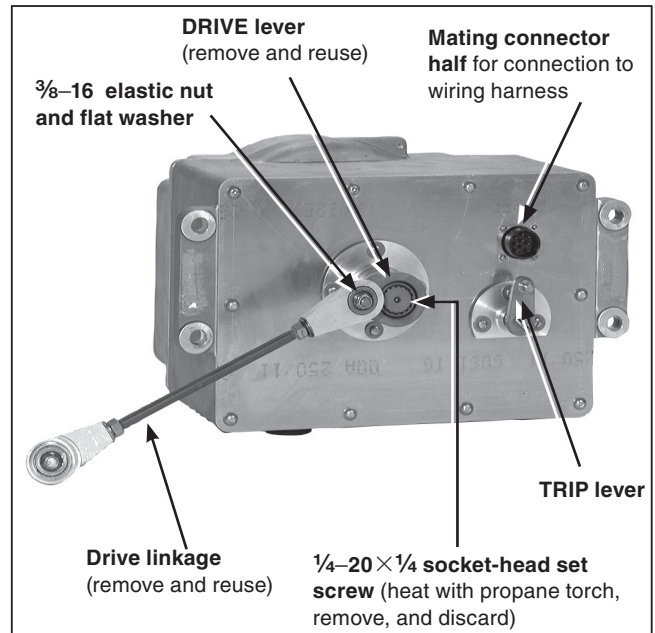

Figure 6. Disconnecting the DRIVE lever.

Replacing the Operating Mechanism

Preparing the Replacement Operating Mechanism

STEP 7. Remove the two $\frac{1}{2}$ -13 \times 1 $\frac{3}{4}$ hex-head galvanized-steel cap screws and hex nuts securing the shipping guard to the replacement operating mechanism. Save the shipping guard and hardware for reuse on the replaced operating mechanism. While handling the replacement operating mechanism with the shipping guard removed, take care to not apply heavy force to the levers on the back of the mechanism. See Figure 7.

STEP 8. Attach the DRIVE lever saved in Step 6 to the shaft on the back of the replacement operating mechanism. Make sure it is oriented in the same manner as shown in Figure 8. The DRIVE lever must be attached so the stud on the lever is pointed horizontally away from the TRIP lever. Coat the threads of a $\frac{1}{4}$ -20 \times $\frac{1}{4}$ socket-head set screw (included with the replacement kit) with a small amount of red Loctite threadlocker and tighten the set screw into the hole in the DRIVE lever.

Reconnect the drive linkage saved in Step 6 to the DRIVE lever on the replacement operating mechanism using a $\frac{3}{8}$ -16 elastic nut (provided with the replacement kit). See Figure 8.

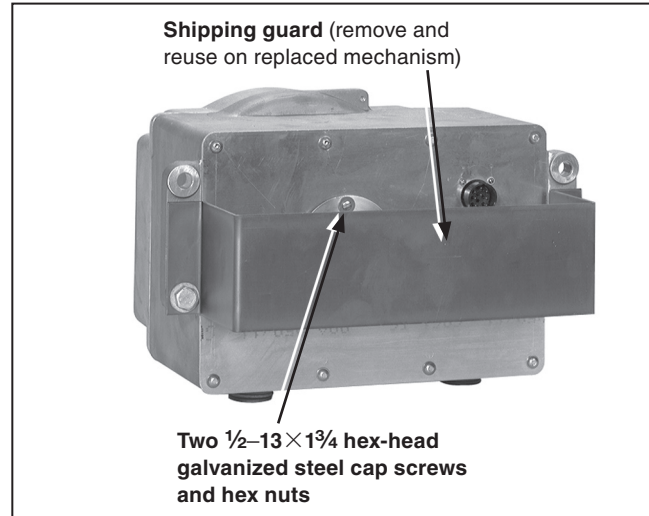

Figure 7. Removing the shipping guard.

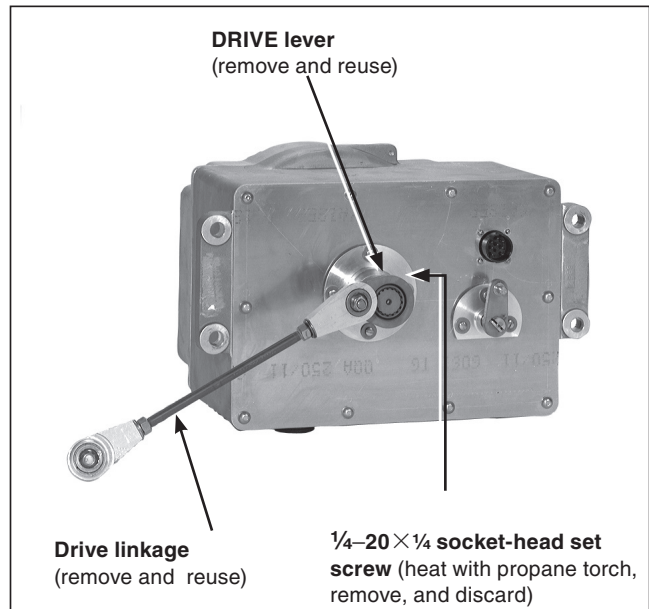

Figure 8. Reattaching the DRIVE lever and drive linkage.

Installing the Replacement Operating Mechanism

STEP 9. Position the replacement operating mechanism onto the captive bolts on the switch base. Make sure the drive linkage is positioned toward the connecting stud on the interphase linkage. Securely tighten $\frac{1}{2}$ -13 hex nuts and flat washers (provided with the replacement kit) onto the two captive bolts. Then, securely tighten the two $\frac{1}{2}$ -13 \times 1 $\frac{1}{2}$ hex-head stainless steel cap screws and flat washers saved from Step 5 into the threaded holes. See Figure 9.

STEP 10. Reconnect the circular plastic connector from the wiring harness to the mating connector half on the back of the operating mechanism. First, visually align the two retainers on the plastic harness connector to the two tabs of the mating connector on the mechanism, along with the proper internal pin alignment. Then, push the harness connector down on the mechanism connector with a left to right rocking motion to seat the tabs into the retainers. A distinct and audible “snap-snap” indicates the mechanism connector and the harness connector are properly seated. Finally, pull hard on the harness connector to ensure the connection is tight. See Figure 10.

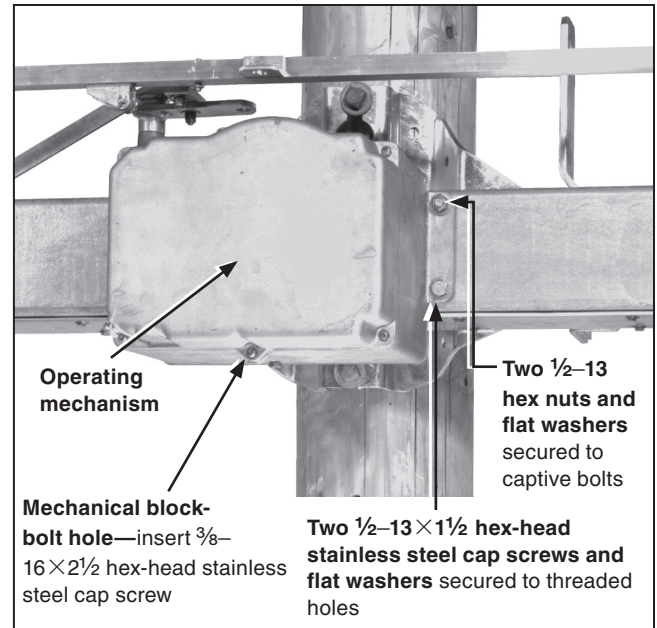

Figure 9. Installing the operating mechanism.

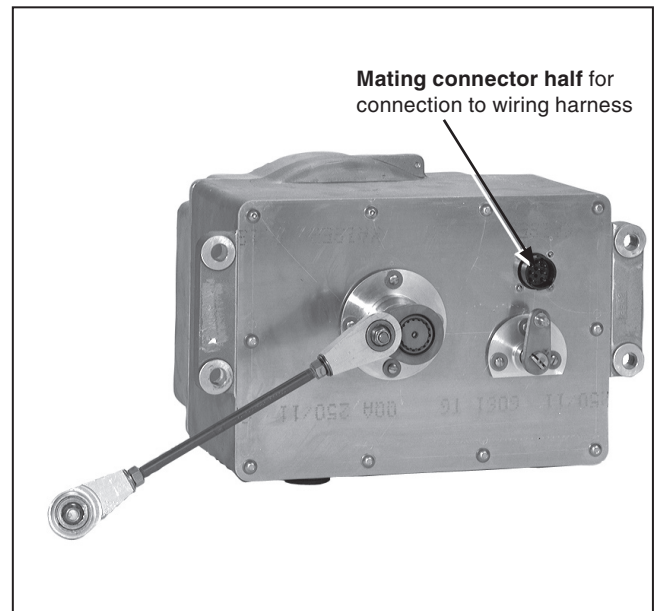

Figure 10. Reattaching connectors from the harness to the operating mechanism.

Replacing the Operating Mechanism

STEP 11. Make sure the interrupter contacts are still in the fully **Open** position by pushing the interphase linkage as far as possible to the **Open** position to the right when viewed as shown in Figure 11. Reattach the uni-ball joint on the drive linkage to the connecting stud on the interphase linkage using a $\frac{5}{16}$ -18 elastic nut and flat washer (provided with the replacement kit).

STEP 12. Reattach the trip linkage to the TRIP lever using a cotter pin and flat washer (provided with the replacement kit).

Locate the slotted connection between the trip linkage and the handle linkage. (For tiered-outboard switches, the trip linkage will pass through an idler-arm assembly that translates motion.) Additional access panels may need to be removed from the switch base. Remove and discard the two $\frac{1}{4}$ -20 \times $\frac{3}{4}$ serrated flange bolts and nuts from the slotted connection. Reconnect the trip linkage to the handle linkage by loosely assembling new serrated flange bolts and nuts (provided with the replacement kit) through the slotted portion of the linkages. Pull the linkages toward each other and securely tighten the flange bolts and nuts. See Figure 12.

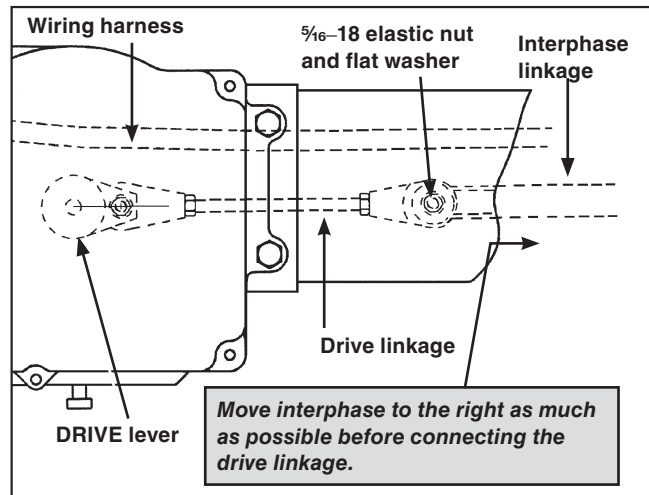

Figure 11. Ensuring the interrupter contacts in the fully Open position.

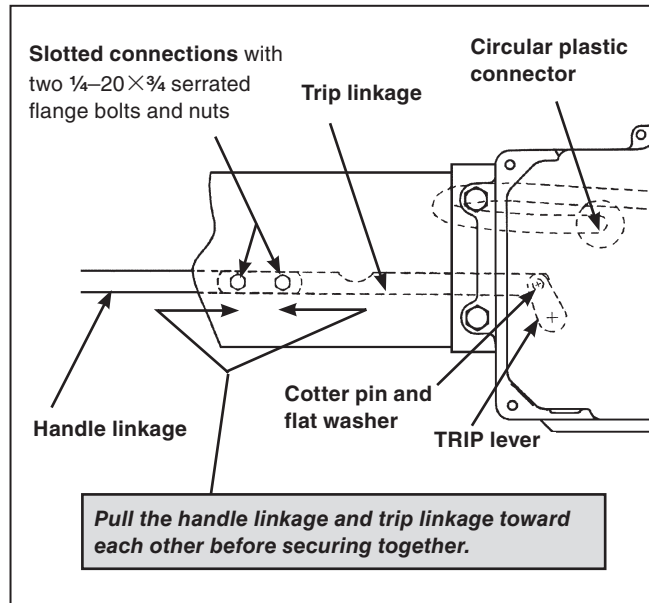

Figure 12. Pull the linkages toward each other and securely tighten the flange bolts and nuts.

STEP 13. Reinstall the access panels removed in Step 2. Then, remove the blocking bolt from the mechanism and replace it with the short bolt removed in Step 1. See Figure 13.

⚠ WARNING

To avoid **serious personal injury**, do not operate the switch unless the access panels on the switch base have been reinstalled.

NOTICE

Do not operate the switch with the mechanism blocking bolt installed. **Damage to the operating mechanism could result.**

STEP 14. Place the power switch on the battery charger in the control unit in the **On** position. Make sure the LOCAL/REMOTE switch on the switch control is in the **Local** position. Perform operational checkout on the de-energized switch as follows:

- (a) Open and close the disconnect several times via the disconnect handle to verify all linkages move freely.
- (b) With the disconnect fully closed and latched (handle in closed toggle), confirm the switch opens and closes via the OPEN/CLOSE pushbuttons in the control unit.
- (c) With the disconnect fully closed and latched (handle in closed toggle) and the interrupter contacts closed, confirm moving the manual operating handle toward the **Open** position causes the switch to trip open before the disconnect opens.
- (d) With the disconnect closed but not latched (handle out of toggle), confirm that the OPEN/CLOSE pushbuttons are disabled.

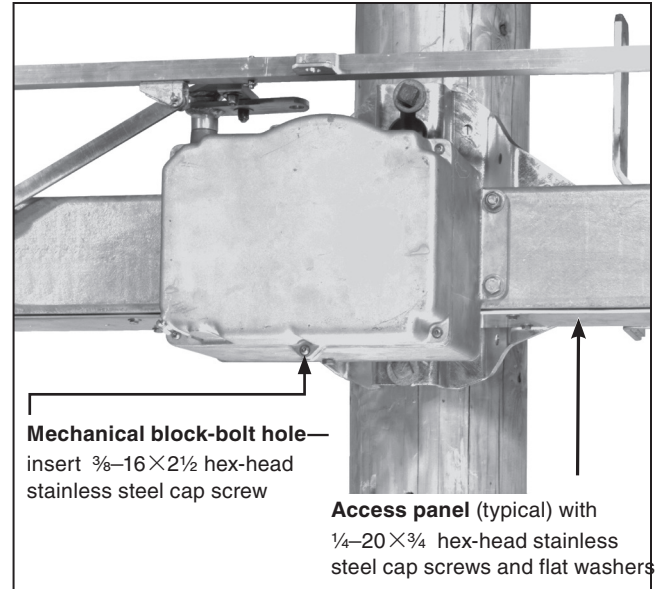

Figure 13. Reinstalling the access panel(s).

Replacing the Operating Mechanism

STEP 15. Attach the shipping guard and hardware saved in Step 7 to the replaced high-speed operating mechanism. See Figure 14. Set the replaced operating mechanism in to the replacement operating mechanism crate. Secure the operating mechanism and close the lid. Ship the replaced operating mechanism, transportation charges prepaid, to S&C Electric Company, Repair Center. For product returns, contact a local S&C representative for proper return material authorization documentation.

To ensure proper handling, purchasers are asked to obtain from the nearest S&C Sales Office a special serially numbered label to place on the shipping crate. Please enclose a packing slip showing the purchase order or requisition number covering the exchange.

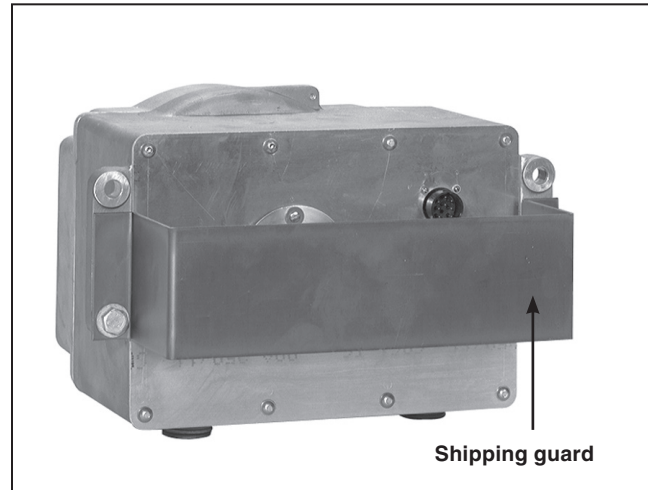

Figure 14. Attaching the shipping guard.