

Installation

Table of Contents

Section	Page	Section	Page	
Introduction		Packing and Inspection		
Operating Considerations	2	Packing	7	
Qualified Persons	2	Inspection	7	
Read this Instruction Sheet	3	Handling	7	
Retain this Instruction Sheet.	3	Installation		
Proper Application	3	Operating Mechanism Assembly	8	
Warranty	3	Mounting to Wood	8	
Safety Information		Mounting the Switch Assembly	9	
Understanding Safety-Alert Messages	4	Installing the Optional Pole Band	10	
Following Safety Instructions	4	Installing the Optional Wildlife Protection	11	
Replacement Instructions and Labels	4	Checking Operation	15	
Location of Safety Labels	5	Dead-Ending Conductors	20	
Safety Precautions		6	Connecting High-Voltage Conductors	20
		Operation		
		Before Starting	23	

▼ For installation instructions for Omni-Rupter Switches with Catalog Number Supplement "R4," please refer to your local S&C Sales Office. These instructions are also available on www.sandc.com.

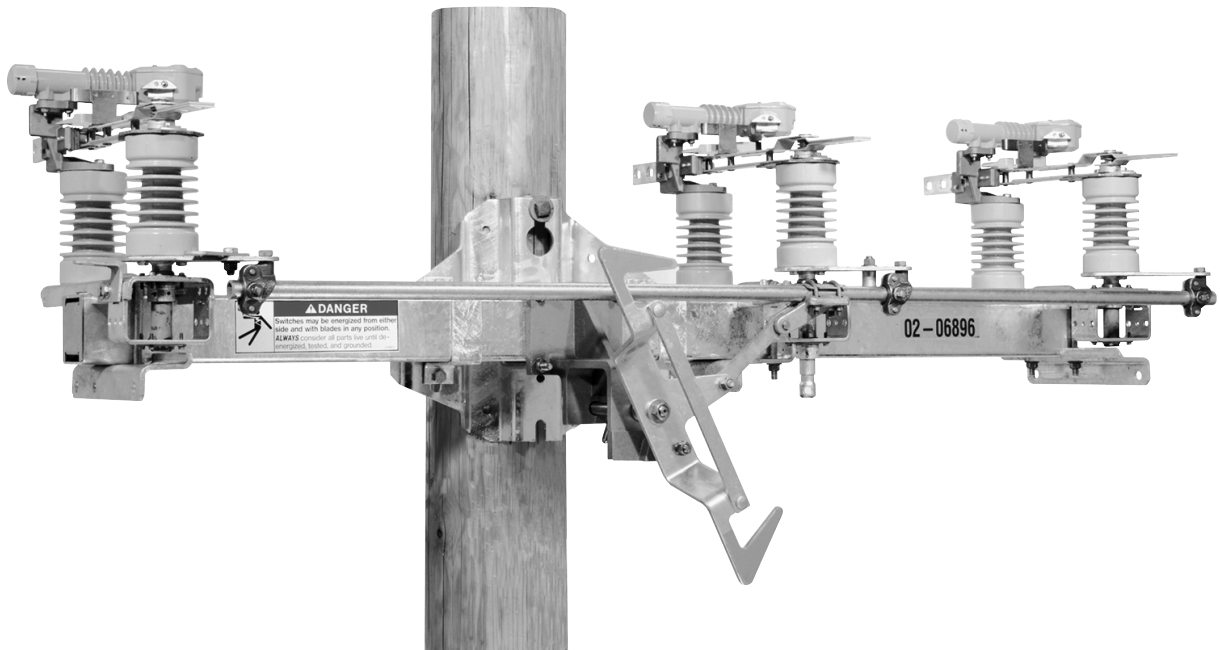

Operating Considerations

CAUTION

The equipment covered by this publication must be selected for a specific application and it must be installed, operated, and maintained by qualified persons who are thoroughly trained and who understand any hazards that may be involved. This publication is written only for such qualified persons and is not intended to be a substitute for adequate training and experience in safety procedures for this type of equipment.

In most applications, these interrupter switches are capable of switching rated continuous load currents at full voltage. Consequently, no interlocking with secondary protective equipment is required.

Circuit making and breaking is involved in the normal operation of these interrupter switches and, as a result, precautionary “partway” opening or closing is undesirable. To operate, pull the operating handle down with a hookstick, through its full stroke without hesitation. Do not assume that the operating-handle position necessarily indicates the open or closed position of the interrupter-switch blades. Upon completion of an opening or closing operation, visually check the position of the interrupter-switch blades to determine that the intended position has been attained. *For hookstick-operated upright mounting configuration*, the switch can only be operated from the ground or bucket and not at the pole. **Note:** These interrupter switches are not intended for breaking fault currents.

Qualified Persons

WARNING

The equipment covered by this publication must be installed, operated, and maintained by qualified persons who are knowledgeable in the installation, operation, and maintenance of overhead electric power distribution equipment along with associated hazards. A qualified person is one who is trained and competent in:

- The skills and techniques necessary to distinguish exposed live parts from nonlive parts of electrical equipment.
- The skills and techniques necessary to determine the proper approach distances corresponding to the voltage to which the qualified person will be exposed.
- The proper use of the special precautionary techniques, personal protective equipment, insulating and shielding materials, and insulated tools for working on or near exposed energized parts of electrical equipment.

These instructions are intended only for such qualified persons. They are *not* intended to be a substitute for adequate training and experience in safety procedures for this type of equipment.

**Read this
Instruction Sheet**

Thoroughly and carefully read this instruction sheet before installing or operating your S&C Omni-Rupter Switch. Familiarize yourself with “SAFETY INFORMATION” on pages 4 and 5.

**Retain this
Instruction Sheet**

NOTICE

These instructions are for Omni-Rupter Switches with Catalog Number Supplement “R3” and earlier. For installation instructions for Omni-Rupter Switches with Catalog Number Supplement “R4,” please refer to your local S&C Sales Office. These instructions are also available on www.sandc.com.

This instruction sheet is a permanent part of your S&C Omni-Rupter Switch. Designate a location where you can easily retrieve and refer to this publication.

Proper Application

⚠ CAUTION

The equipment in this publication must be selected for a specific application. The application must be within the ratings furnished for the equipment. Refer to S&C Specification Bulletin 765-31 for complete application information.

In most applications, these interrupter switches are capable of switching rated continuous load currents at full voltage. Consequently, no interlocking with secondary protective equipment is required.

Warranty

The standard warranty contained in S&C’s standard conditions of sale, as set forth in Price Sheet 150, is applicable to the S&C Omni-Rupter Switch covered in this instruction sheet except when it is power operated using a switch operator of other than S&C manufacture.

Safety Information

Understanding Safety-Alert Messages

There are several types of safety-alert messages which may appear throughout this instruction sheet as well as on labels and tags attached to the Omni-Rupter Switch. Familiarize yourself with these types of messages and the importance of the various signal words, as explained below.

DANGER

“DANGER” identifies the most serious and immediate hazards which *will likely* result in serious personal injury or death if instructions, including recommended precautions, are not followed.

WARNING

“WARNING” identifies hazards or unsafe practices which *can* result in serious personal injury or death if instructions, including recommended precautions, are not followed.

CAUTION

“CAUTION” identifies hazards or unsafe practices which *can* result in minor personal injury or product or property damage if instructions, including recommended precautions, are not followed.

NOTICE

“NOTICE” identifies important procedures or requirements that, if not followed, *can* result in product or property damage if instructions are not followed.

Following Safety Instructions

If you do not understand any portion of this instruction sheet and need assistance, contact your nearest S&C Sales Office or S&C Authorized Distributor. Their telephone numbers are listed on S&C’s website www.sandc.com. Or call S&C Headquarters at (773) 338-1000; in Canada, call S&C Electric Canada Ltd. at (416) 249-9171.

NOTICE

Thoroughly and carefully read this instruction sheet before operating your S&C Omni-Rupter Switch.



Replacement Instructions and Labels

If you need additional copies of this instruction sheet, contact your nearest S&C Sales Office, S&C Authorized Distributor, S&C Headquarters, or S&C Electric Canada Ltd.

It is important that any missing, damaged, or faded labels on the equipment be replaced immediately. Replacement labels are available by contacting your nearest S&C Sales Office, S&C Authorized Distributor, S&C Headquarters, or S&C Electric Canada Ltd.

Location of Safety Labels

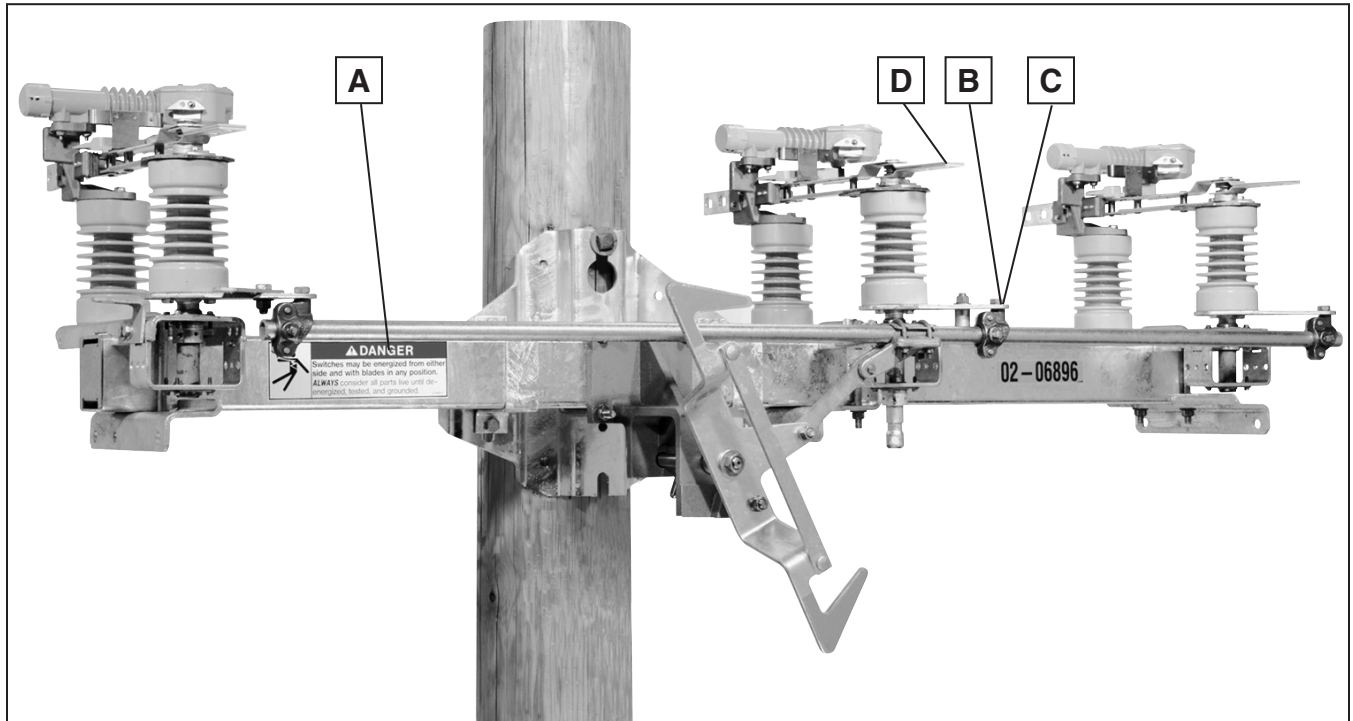

REORDER INFORMATION FOR SAFETY LABELS

Location	Safety Alert Message	Description	Number
A	⚠ DANGER	Switches may be energized from either side and with blades in . . .	G-6580-1★
B	⚠ WARNING	Lifting Instructions	G-5928R3▲
C	NOTICE	Do not remove this lifting bracket until switch . . .	G-4776R1▲
D	NOTICE	To avoid overloading the terminal pads . . .	G-9094▲

★ This label is placed on both sides of switch base on opposite ends.

▲ This part is a tag which is to be removed and discarded after the switch is installed and adjusted.

⚠ DANGER



Omni-Rupter Switches operate at high voltage. Failure to observe the precautions below will result in serious personal injury or death.

Some of these precautions may differ from company operating procedures and rules. Where a discrepancy exists, users should follow their company's operating procedures and rules.

1. **QUALIFIED PERSONS.** Access to switches and controls must be restricted only to qualified persons. See "Qualified Persons" on page 2.
2. **SAFETY PROCEDURES.** Always follow safe operating procedures and rules.
3. **PERSONAL PROTECTIVE EQUIPMENT.** Always use suitable protective equipment such as rubber gloves, rubber mats, hard hats, safety glasses, and flash clothing in accordance with safe operating procedures and rules.
4. **SAFETY LABELS AND TAGS.** Do not remove or obscure any of the "DANGER," "WARNING," "CAUTION," or "NOTICE" labels and tags. Remove tags ONLY if instructed to do so.
5. **ENERGIZED COMPONENTS.** Always consider all parts live until de-energized, tested, and grounded.
6. **OPERATING TOOL.** To open and close the hookstick operated Omni-Rupter, use a conventional insulated hookstick or S&C Universal Pole and Pole Extension fitted with a heavy-duty prong such as the S&C Substation Prong or equivalent.
7. **LOAD-INTERRUPTER SWITCH POSITION.** Always confirm the open/close position of load-interrupter switches by visually observing the position of the blades. Switches may be energized from either side and with the blades in any position.
8. **MAINTAINING PROPER CLEARANCE.** Always maintain proper clearance from energized components.
9. **OPERATION.** Circuit making and breaking is involved in the normal operation of this interrupter switch and, as a result, "partway" opening or closing is undesirable. To operate, pull the operating handle down through its full travel vigorously and without hesitation. See "Checking Operation" on page 15.

Packing

The hookstick-operated S&C Omni-Rupter Switch includes the following:

1. A three-pole hookstick group-operated integer-style upright mounted switch.
2. Miscellaneous mounting hardware (less through-bolts) for securing the Omni-Rupter switch to the pole.
3. An ED drawing for the Omni-Rupter will be found in a water-resistant envelope shipped with the switch. Study this drawing carefully and check the bill of material to be sure that all parts are at hand.

Inspection

Examine the shipment for external evidence of damage as soon after receipt as possible, preferably before removal from the carrier's conveyance. Check the bill of lading to make sure that shipping skids, crates, and containers listed thereon are present:

If there is visible loss and/or damage:

1. Notify the delivering carrier immediately.
2. Ask for a carrier inspection.
3. Note condition of shipment on all copies of the delivery receipt.
4. File a claim with the carrier.

If concealed damage is discovered:

1. Notify the delivering carrier within 15 days of receipt of shipment.
2. Ask for a carrier inspection.
3. File a claim with the carrier.

Also notify S&C Electric Company in all instances of loss and/or damage.

Handling

WARNING

Lift the switch using the lifting brackets provided. Do not allow lifting slings to stress switch parts. Avoid allowing switch to swing while lifting

Lifting the switch by the live parts or pole-unit bases will damage the switch. Rough handling may cause misalignment of the blades and contacts.

Failure to lift the switch properly can result in switch damage, causing improper operation, arcing or electrical shock.

NOTICE

DO NOT remove the lifting brackets until the switch has been lifted into place and bolted to the pole.

Installation

Operating Mechanism Assembly

The operating mechanism is shipped partially disassembled, so some minor reassembly is required to prepare the switch for installation. Because the switch and mechanism are fully assembled and adjusted at the factory, no adjustments should be required after this assembly.

⚠ WARNING

During the minor reassembly of the operating mechanism you must exercise care when opening and closing the switch.

It is important, when rotating the handle, that it be rotated slowly, and in a manner which prevents your hands/fingers from being pinched between the inside of the handle and other parts of the switch.

Step 1

Remove the tape securing the operating handle linkage, as shown in Figure 1.

Step 2

With the switch in a partially open position, use the pin and X-washer provided to connect the operating handle and linkage, as shown in Figure 2.

Mounting to Wood

When mounting the switch to a wood pole, it is recommended that suitably sized square washers be placed under the nuts. The use of spring-type washers between the square washers and nuts is also recommended to compensate for wood-pole shrinkage and thus maintain fastener tightness.

Square and spring-type washers are not included with the switch.

Step 3

Drill two $\frac{11}{16}$ -inch diameter holes in the utility pole at the desired height for mounting the switch. Refer to the erection drawing for details.

Step 4

Insert two $\frac{5}{8}$ -inch diameter through-bolts (not furnished) in the holes drilled in Step 1 and secure loosely with the necessary square washers and nuts in such a manner that the heads of the bolts project sufficiently from the face of the pole to engage the switch-base mounting bracket.

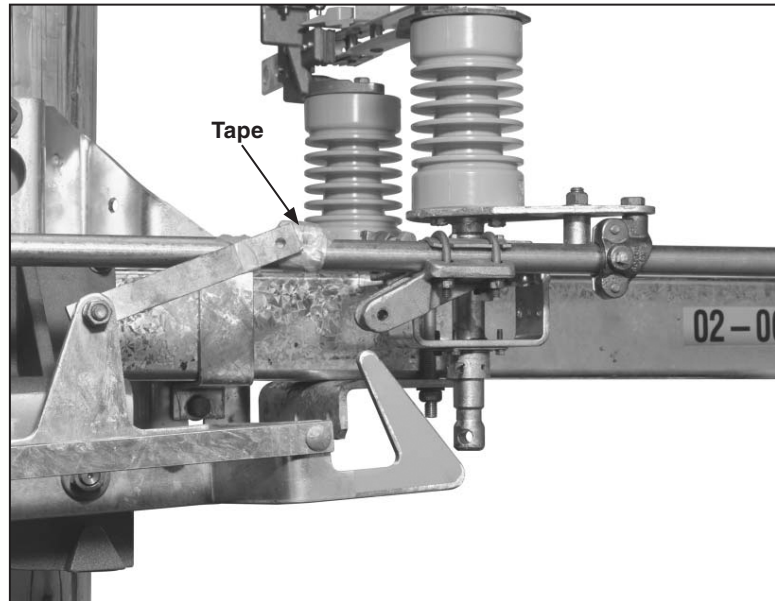

Figure 1. Removal of tape securing the operating linkage.

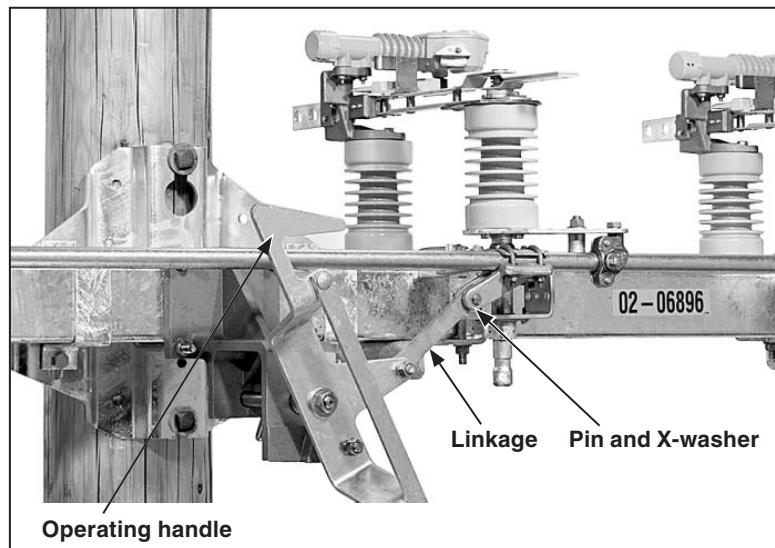

Figure 2. Install pin and X-washer to connect linkage.

Mounting the Switch Assembly

Step 5

⚠ WARNING

Lift the switch using the lifting brackets provided. Do not allow lifting slings to stress switch parts. Avoid allowing switch to swing while lifting.

Lifting the switch by the live parts or pole-unit bases will damage the switch. Rough handling may cause misalignment of the blades and contacts.

Failure to lift the switch properly can result in switch damage, causing improper operation, arcing or electrical shock.

Like all switches in the upright mounting configuration, the hookstick-operated switches are provided with two lifting brackets bolted to a 4" × 4" wood support member which is, in turn, attached to the switch base. Since the wood support member is also a part of the shipping skid, use care to avoid damage to it during unpacking.

Make sure that the switch is fully closed. Attach hoisting slings to the lifting brackets and take a light strain. Unbolt the wood support member from the skid. Then slowly and carefully hoist the switch as shown in Figure 3.

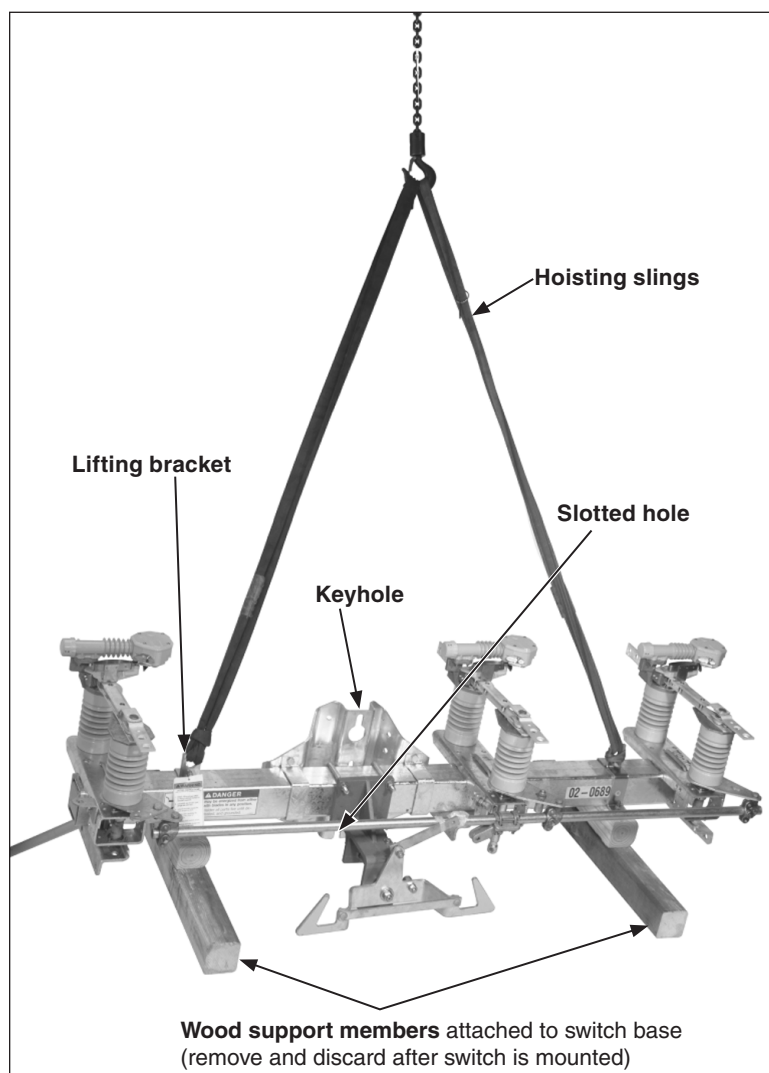

Figure 3. Hoisting the Omni-Rupter Switch into position.

Installation

When the switch assembly is hoisted to its mounting level, guide the assembly so that the through-bolts projecting from the utility pole slip into the holes in the switch's mounting bracket.

(The bracket is provided with a keyhole and an open slotted hole for this purpose; see Figure 3.) Lower the switch slightly so that it bears on the through-bolts. Fully tighten the through-bolts. See Figure 4.

Remove the lifting brackets and wood support members which were provided to facilitate hoisting of the switch. If desired, a crossarm brace (user-furnished) may be attached to the base. Mounting brackets for crossarm braces must be specified separately. Consult your nearest S&C Sales Office for details.

Installing the Optional Pole Band

Step 6

Secure the pole band (optional) to the mounting bracket on the switch, using the J-bolts provided. See Figure 4, below. Two $\frac{1}{4}'' \times 1'' \times 3''$ stiffening blocks are furnished to be used behind the pole-band flanges, and underneath the J-bolt nuts. Lag the pole band to the back side of the pole through the hole in the center of the band, using one of the three $\frac{1}{2}$ -inch diameter lag screws provided. Then, lag the mounting bracket to the pole using the two remaining $\frac{1}{2}$ -inch lag screws as shown in Figure 4.

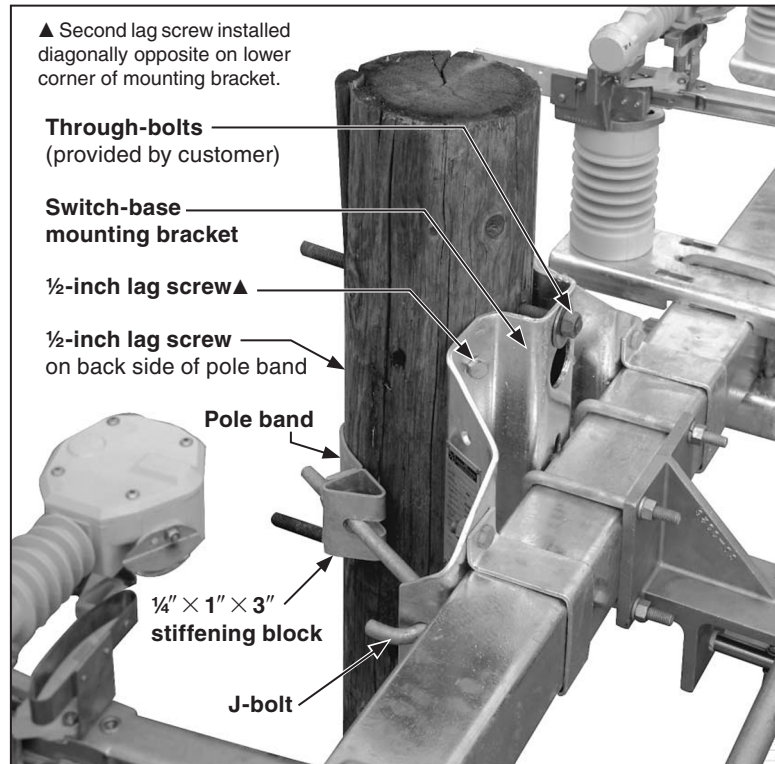

Figure 4. Typical pole-band attachment detail.

Installing the Optional Wildlife Protection (Catalog Number Suffix “-W”)

⚠ DANGER

De-energize the switch and ground it at all six terminals before installing the wildlife protection option.

The wildlife protection option is not designed to be installed on energized equipment.

Failure to do so could lead to serious injury or death.

The wildlife protection option helps prevent climbing or perching animals from making phase-to-grounded part contact. See Figure 5. A typical wildlife protection installation includes:

- Two base covers (three base covers on switches with extra mounting-pole clearance.) (Base covers are not included on switches with insulated bases.)
- Six wildlife disks.
- One pole-saddle cover (not required when switch with extra mounting-pole clearance is specified), pre-installed.
- One fiberglass interphase operating rod, pre-installed.

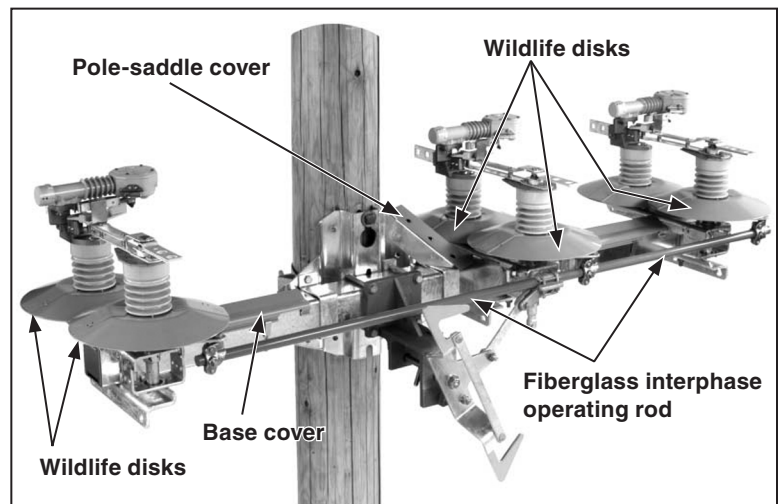

Figure 5. 14.4-kV Omni-Rupter with Optional Wildlife Protection (Catalog Number Suffix “-W”), Upright Mounting Configuration.

NOTICE

S&C recommends installing the wildlife protection option after the switch is secured to the utility pole.

Damage to the wildlife option may occur if lifting slings strain the wildlife disks during handling.

In Figure 5 on page 11, a typical installation of the wildlife protection option is illustrated. The pole-saddle cover will be pre-installed at the factory, as will the fiberglass interphase operating rod. Consult the RD drawing accompanying the switch installation instructions for details specific to your switch that may differ from the instructions below. Following are instructions for a typical field installation of the wildlife protection option.

Step 7

Installing the Base Covers:

With the switch in the closed position, place the base covers onto the steel base of the switch in the positions shown on the associated RD drawing. If optional surge arrester mounting provisions (Catalog Number Suffix “-A1” or “-A2”) have been specified for the switch, cutouts will be provided in the base covers to fit around the arrester mounting brackets.

Step 8

Hook one end of the spring clip assembly into the lip on the edge of one side of the base cover. See Figure 6. Bring the spring clip underneath the switch base and stretch it until it can be hooked into the lip on the edge of the opposite side of the base cover. Make sure the spring clip is at least one-half inch from the edge of the base cover. See Figure 7. Install the remaining spring clips on their respective base covers in accordance with the supplied RD drawing.

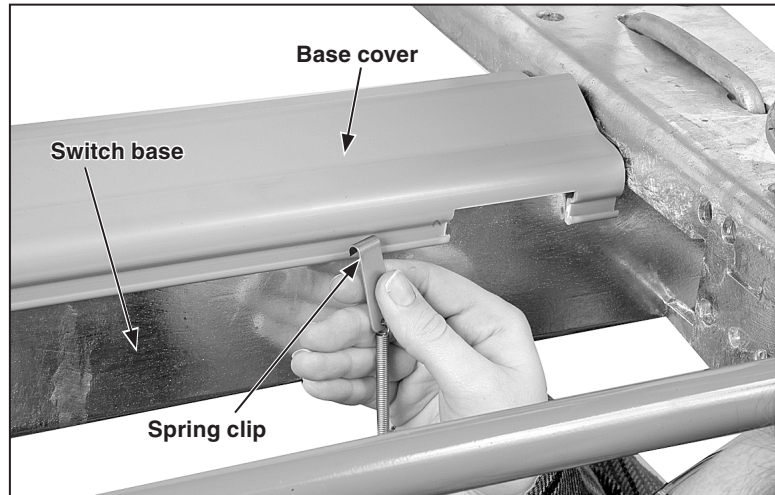

Figure 6. Hook one end of spring clip into base cover lip. Stretch underneath base and hook on opposite side.

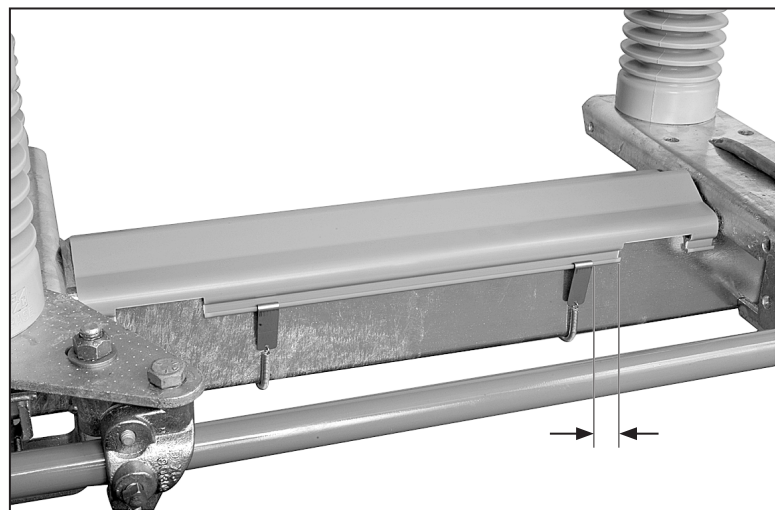

Figure 7. Make sure clips are installed 1/2-inch from edge of cover.

Before Starting

Installing the Wildlife Disks:

Before installing the wildlife disks, determine the proper placement of the disks on the switch blade and contact insulators.

On 14.4-kV Omni-Rupter Switches (Porcelain and Cypoxy® Insulators)

Install the wildlife disk to the bottom skirt root of the insulator on both the blade and contact ends of the switch. When the wildlife disks are properly installed, the disks will overlap slightly as shown in Figure 8.

On 25-kV Omni-Rupter Switches (Porcelain and Cypoxy® Insulators)

Blade end of the switch: Install the wildlife disk on the bottom skirt root of the insulator.

Contact end of the switch: Count up two skirts from the base and install the wildlife disk to the insulator. When the wildlife disks are installed properly, they will be at approximately the same height. See Figure 9.

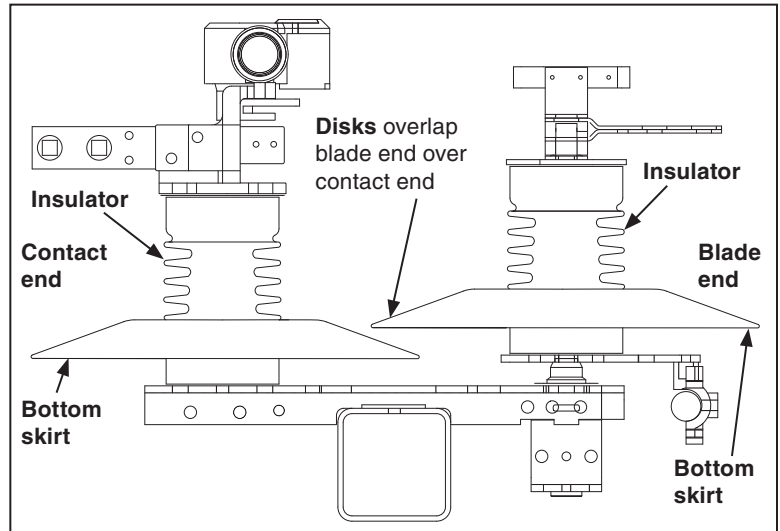

Figure 8. Wildlife disk placement on 14.4-kV Omni-Rupter Switches.

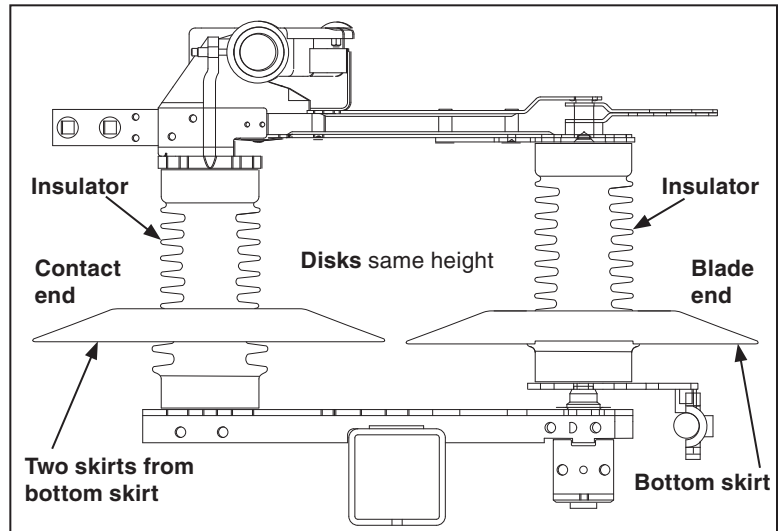

Figure 9. Wildlife disk placement on 25-kV Omni-Rupter Switches.

Step 9

- a. To assemble the disks, fit the disk around the insulator on the blade-end of the switch. See Figure 10. Then, insert the locking tabs of one-half of the disk into the open slot on the other half to create a secure overlapping fit. Repeat the procedure on the opposite side of the disk. When the halves are correctly assembled, the S&C logo will be on top of the disk on both sides. See Figure 11.
- b. Starting with the outside locking tabs first, squeeze the overlapping sides together until the tabs audibly snap into place.
- c. Push the two halves of the disk together in towards the insulator so that it fits the insulator as close as possible. See Figure 12. Snap the upper locking tab firmly into place. Both tabs should protrude through the open slot as shown in Figure 11.
- d. Repeat a. through c. above to install the wild-life disks on the insulators on the contact-end of the switch.

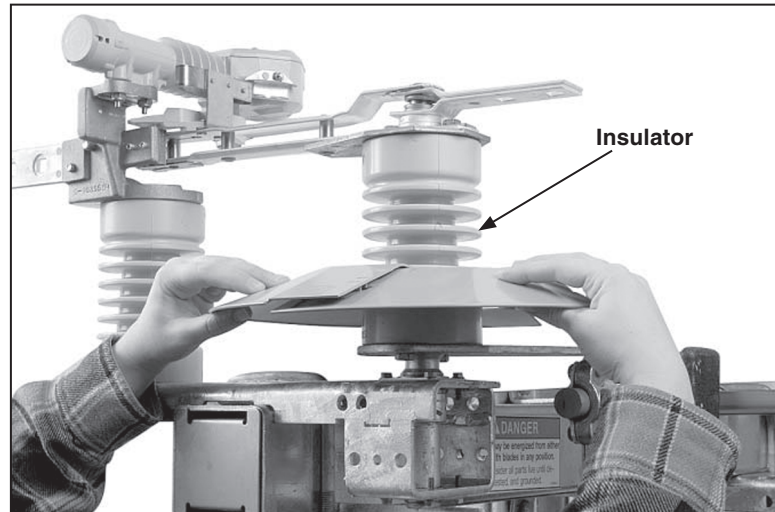

Figure 10. Fit the disk halves around the insulator.

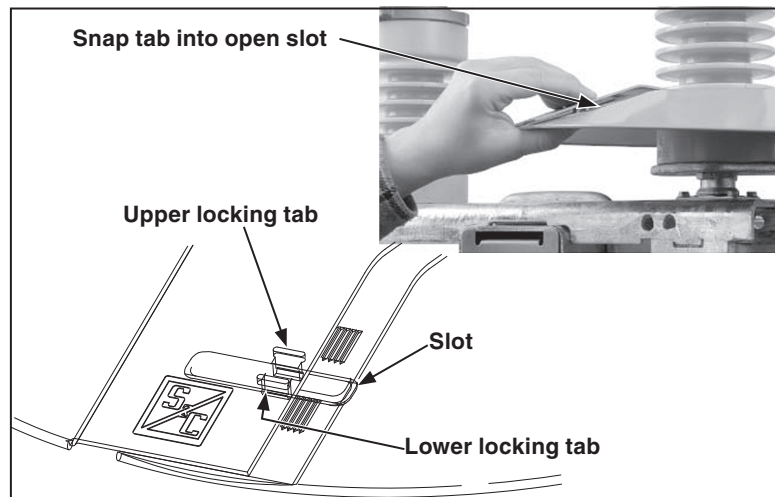

Figure 11. Snap lower tab into open slot.

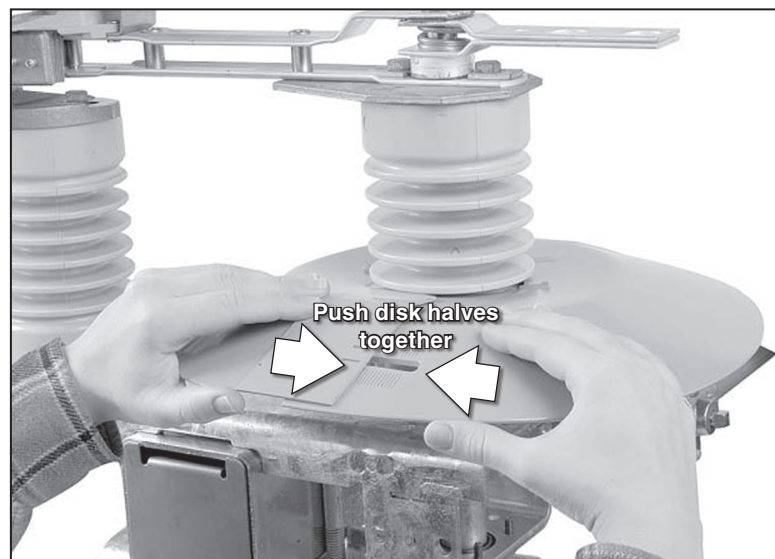

Figure 12. Push disk halves together. Snap upper tab into place. Disk halves should fit as tight against the insulator as possible.

Checking Operation

Step 10

Open and close the interrupter switch by pulling the hook stick operating mechanism slowly through its full travel. Check to be sure that the following conditions exist:

- a. With the operating handle as far as it will go in the closing direction, all main contacts of the interrupter switch are in the fully-closed position.
- b. With the operating handle as far as it will go in the opening direction, the switch blades are 90° from the closed position.

If adjustment is required, loosen the hinge-end bolts that fasten the blade assembly to its insulator and move the switch blade until it is in the fully-closed position with the blade against the bumper stop; then re-tighten the bolts making sure the blade remains in the fully-closed position. (Cypoxy Insulators—torque the $\frac{3}{8}$ -16 hardware to 22 ft-lbs; Porecelain Insulators—torque the $\frac{1}{2}$ -13 hardware 55 ft-lbs.)

If adjustment is required *beyond* that provided by moving the switch-blade assembly, loosen the two clamping bolts and set screw that fasten the coupling to the interphase rod and rotate the switch blade until it is in the fully-closed position. Re-tighten the clamping bolts and set screw, making sure the interrupter switch remains in the fully closed position.

Step 11

Open and close the switch to verify:

- In the closed position, the operating handle and linkage should be in toggle as shown in Figure 15. There should be 25-35 pounds of force required to move the handle out of toggle.
- In the open position, a lesser but still noticeable force should be required to initiate closing of switch.

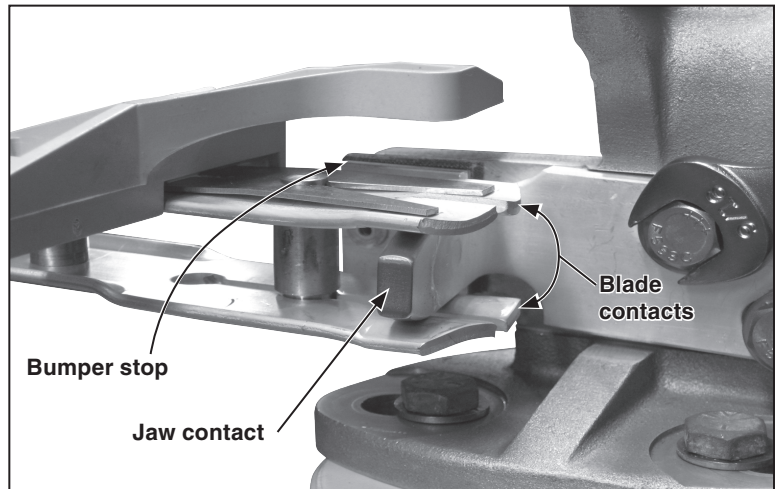

Figure 13. Make sure the jaw contact is fully-centered between the blade contacts and that the blade contacts are against the bumper stop.

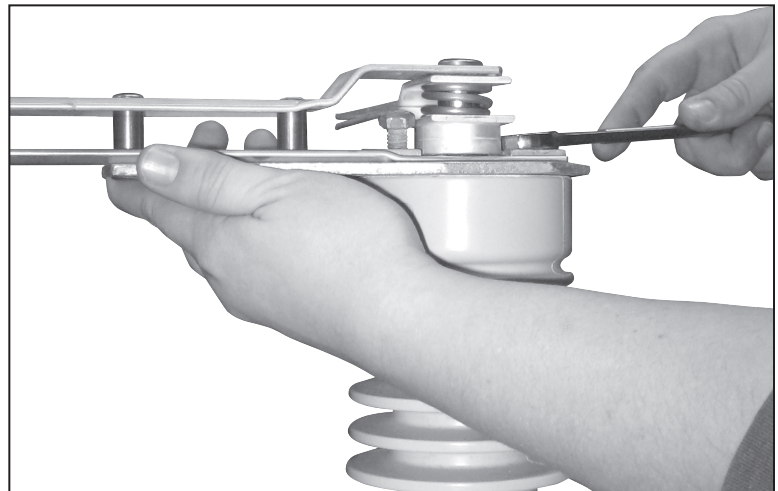

Figure 14. Loosen the blade hardware if necessary and move blade to the fully-closed position against the bumper stop.

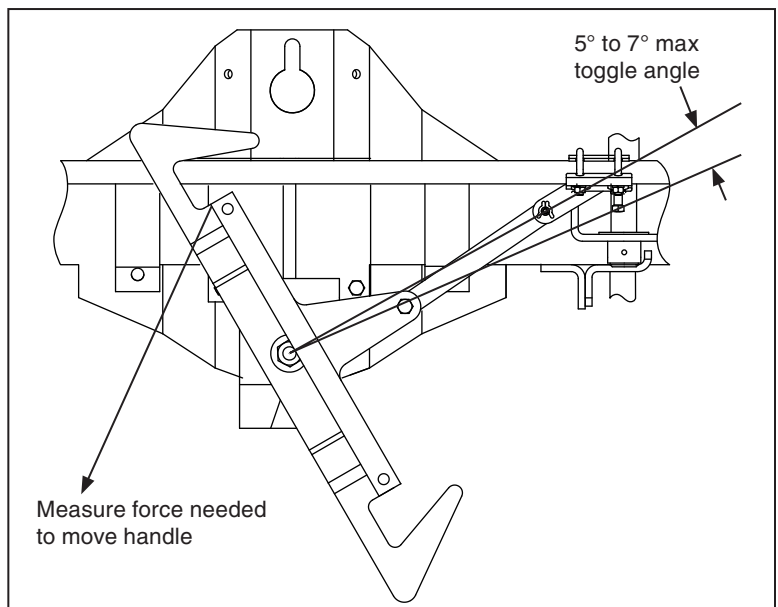

Figure 15. Handle and linkage in toggled position.

Installation

Step 12

For 14.4-kV switches. Check the following on each phase.

- a. Open and close the switch and examine the interrupter and blade alignment. The interrupter must be parallel to the sweep of the blade.
- b. Partially open the switch. The following conditions should be met:
 - A $\frac{1}{32}$ " minimum clearance between the **top** of the opening cam and the **bottom** of the closing lever, at their closest point.
 - A $\frac{1}{32}$ " minimum clearance between the **top** of the opening lever and the **bottom** of the closing cam.
- c. Open the switch and place the blade in the position shown in Figure 16, View A. The following conditions should be met:
 - A $\frac{1}{64}$ " minimum clearance between the opening cam and the opening lever.
 - A clearance between $\frac{3}{32}$ " and $\frac{7}{32}$ " between the shunt contact and the interrupter housing at the beginning of the closing sweep.
- d. Place the switch in the fully-closed position. The following conditions should be met:
 - A clearance of $\frac{1}{16}$ " – $\frac{9}{32}$ " between the closing cam and the closing lever.
 - A $\frac{1}{2}$ " minimum clearance between the blade shunt contact and the interrupter housing contact.
- e. Slowly open the switch. As the blade moves in the opening direction, the blade shunt contact must firmly engage the interrupter housing contact before the blade disengages from the jaw contact. Bend and reform the shunt contact if necessary to attain the proper contact.

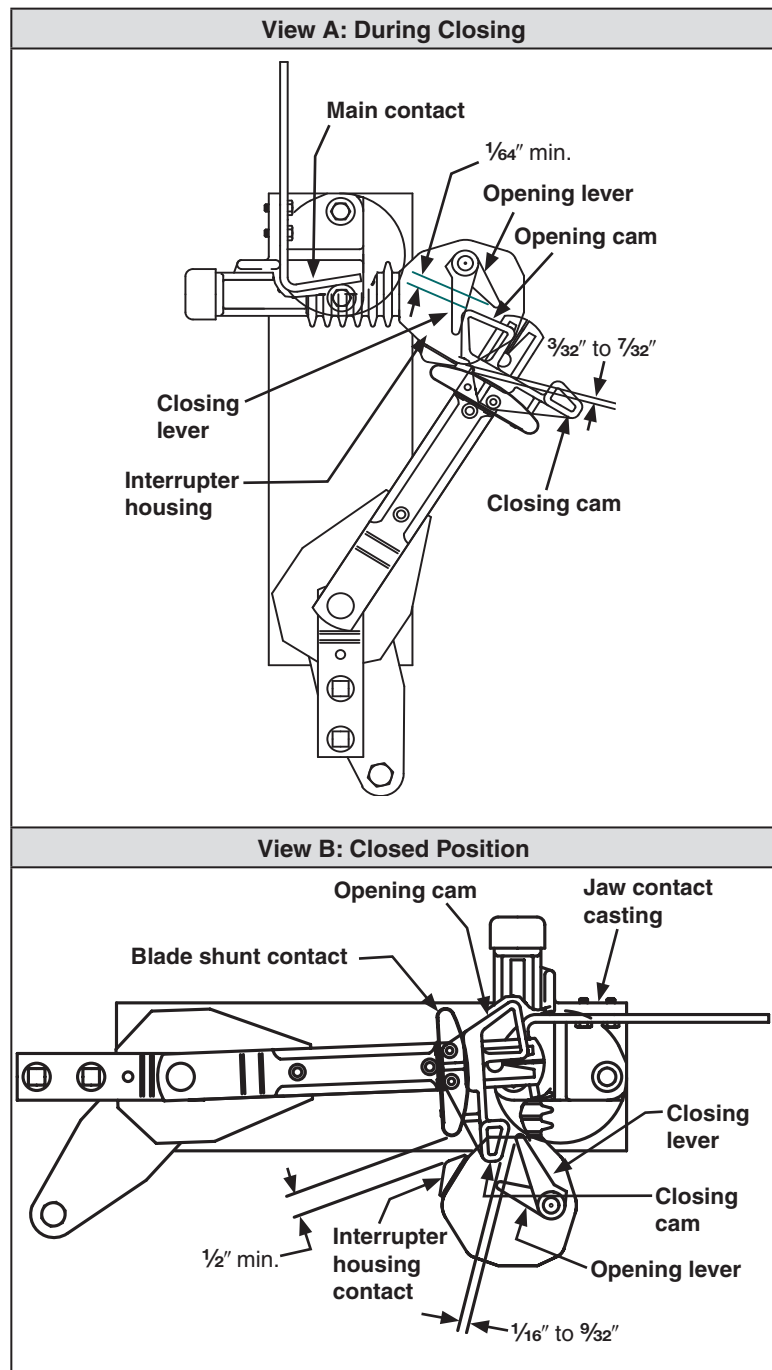

Figure 16. Operating checkpoints for switches rated 14.4 kV.

- f. Slowly close the switch. At the start of the closing stroke, the interrupter housing should be at the distance checked in Step 12c and should continue to make contact with the shunt contact during the duration of the closing stroke. This will ensure that the shunt contact and interrupter housing contact stay in the circuit long enough for the interrupter to break the circuit during the opening stroke.
- g. If adjustment is required, loosen the bolts that fasten the jaw-contact casting to its insulator and slightly rotate the casting in order to achieve the necessary clearances. Re-tighten the bolts, making sure that the blade engages the stationary contact on-center.

NOTICE

If any of the conditions described above cannot be achieved, it is likely that damage was sustained during shipping or storage. Contact the nearest S&C Sales Office for assistance.

NOTICE

Omni-Rupter switches specified with the optional harsh environment contacts (Catalog Number Suffix “-C”) have graphite impregnated blades which are greaseless and self-lubricating.

DO NOT apply grease to the blade contacts.

Installation

Step 13

For 25 kV switches. Check the following on each phase:

- Examine the interrupter and blade alignment. The interrupter must be parallel to the sweep of the blade.
- Partially open the switch. The following conditions should be met:
 - A $\frac{1}{32}$ " clearance between the **bottom** of the opening cam and the **top** of the closing lever
 - A $\frac{1}{32}$ " minimum clearance between the bottom of the closing lever and the top of the blade.
- Open the switch and place the blade in the position shown in Figure 17, View A. The following conditions should be met:
 - A $\frac{1}{64}$ " minimum clearance between the opening cam and the opening lever.
 - A clearance between $\frac{5}{32}$ " and $\frac{7}{32}$ " between the shunt contact and the interrupter housing at the beginning of the closing sweep.
- Place the switch in the fully-closed position. The following conditions should be met:
 - A clearance of $\frac{1}{8}$ " – $\frac{3}{8}$ " between the closing cam and the closing.
 - A $\frac{1}{2}$ " minimum clearance between the blade shunt contact and the interrupter housing contact.
- Slowly open the switch. As the blade moves in the opening direction, the blade shunt contact must firmly engage the interrupter housing contact before the blade disengages from the jaw contact. Bend and reform the shunt contact if necessary to attain the proper contact.

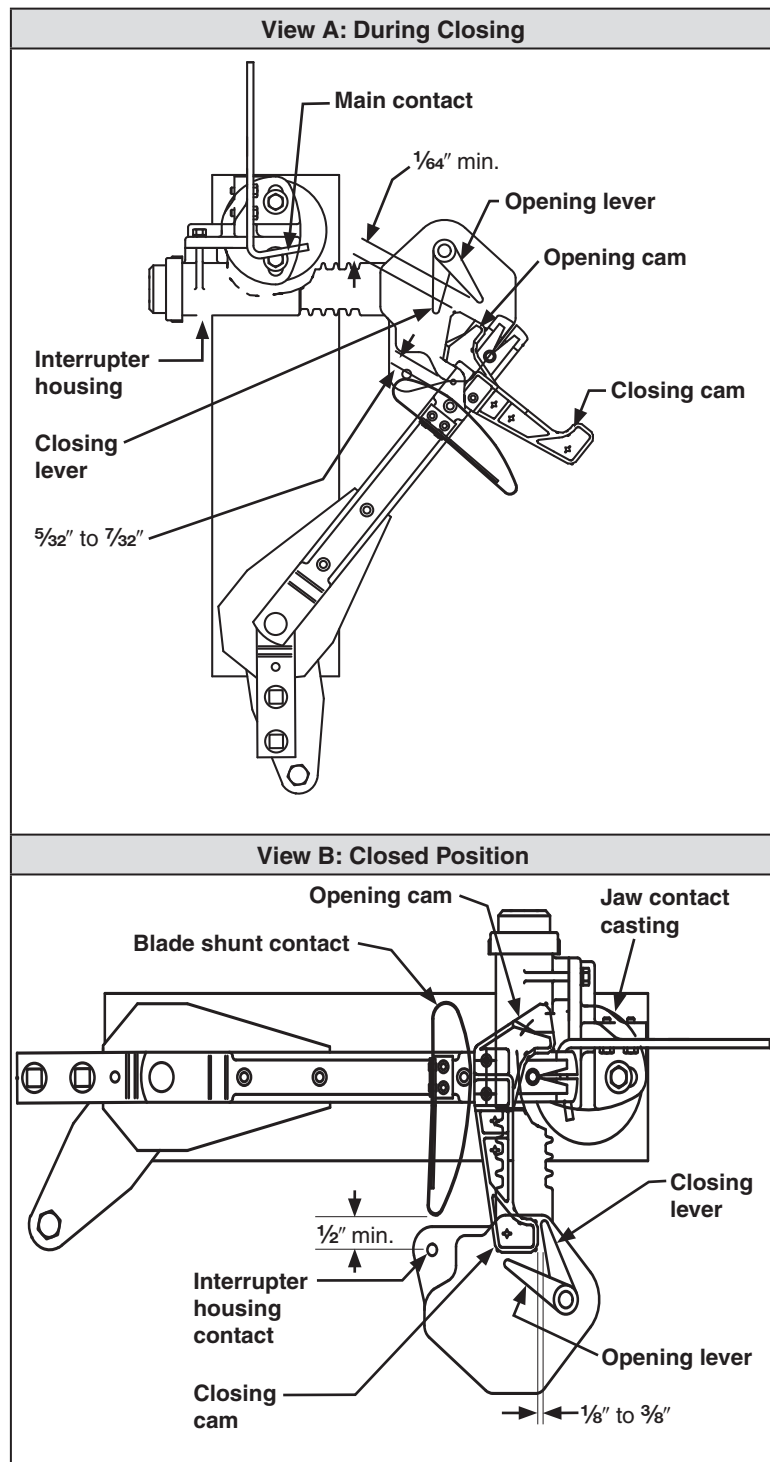

Figure 17. Operating checkpoints for switches rated 25 kV.

- f. Slowly close the switch. At the start of the closing stroke, the interrupter housing should be at the distance checked in Step 13c and should continue to make contact with the shunt contact during the duration of the closing stroke. This will ensure that the shunt contact and interrupter housing contact stay in the circuit long enough for the interrupter to break the circuit during the opening stroke.
- g. If adjustment is required, loosen the bolts that fasten the jaw-contact casting to its insulator and slightly rotate the casting in order to achieve the necessary clearances. Re-tighten the bolts, making sure that the blade engages the stationary contact on-center.

NOTICE

If any of the conditions described above cannot be achieved, it is likely that damage was sustained during shipping. Contact the nearest S&C Sales Office for assistance.

Dead-Ending Conductors

Dead-ending provisions are standard on Omni-Rupter switches that have upright, upright (extra mounting pole clearance), triangular, or tiered-outboard mounting configurations. When dead-ending to these brackets, a pole band and extension-link assemblies ♦ are required. See Figure 18.

Maximum dead-end loading for S&C dead-ending brackets on switches with *steel* bases:

- a. 2000 pounds per conductor where pull-off forces are applied to only one side of the switch.
- b. 8000 pounds per conductor where equal pull-off forces are applied to both sides of the switch.
- c. 1500 pounds per conductor for upright switches *with extra mounting pole clearance* where pull-off forces are applied to only one side of the switch.

Maximum dead-end loading for S&C dead-ending brackets on switches with *insulated* bases:

- a. 750 pounds or 500 pounds per conductor, 14.4-kV and 25-kV respectively, where pull-off forces are applied to only one side of the switch, including upright switches with extra mounting pole clearance.
- b. 8000 pounds per conductor for 14.4-kV and 25-kV switches, where equal pull-off forces are applied to both sides of the switch.

Connecting High-Voltage Conductors

⚠ DANGER

Conductors must be de-energized and grounded in accordance with standard system operating practice.

Failure to do so can result in serious injury or death.

NOTICE

To avoid overloading the terminal pads, S&C recommends making the jumper connection to the line conductor *before* securing jumper fasteners to the terminal pad.

♦ A pole band can be specified by adding suffix “-P1” to the catalog number. Extension-link assemblies can be provided by adding suffix “-D” to the catalog number of the switch, or equivalent user-furnished extension means may be used.

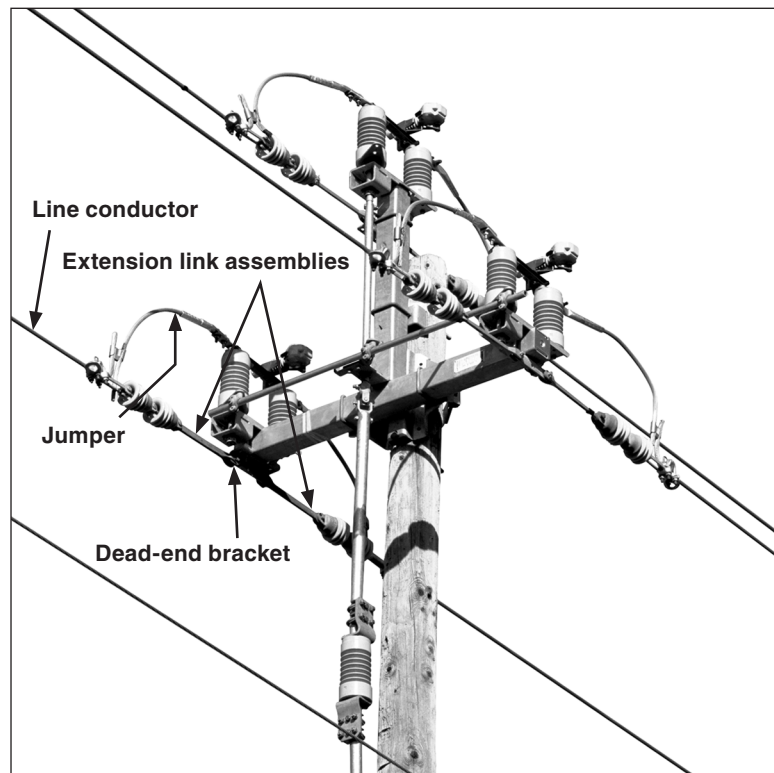

Figure 18. Dead-ending bracket (triangular mounting configuration shown).

The Omni-Rupter terminal pads are silver plated and do not require abrasive cleaning as a part of their preparation. Wipe any dirt or grease from the surface, and apply a thick coating of Penetrox® A or other appropriate conductor preparation compound. **DO NOT** wire-brush the terminal pads. Wire brushing may scratch the plating.

Step 14

CAUTION

DO NOT apply excessive load to the terminal pads.

The jumper connections should be in-line with and level to the terminal pad bolt holes before securing the jumper fasteners to the terminal pad. Large pull-off forces may misalign the blades with the stationary contacts or prevent proper closing

Misaligned contacts may overheat causing arcing and damage to the switch. Injury to operating personnel may result.

When high-voltage conductors are to be connected using aluminum-alloy connectors[■], the following procedures should be employed:

- a. Thoroughly wire-brush the current-transfer surfaces of each connector and immediately apply a liberal coating of Penetrox® A (available from Burndy Corporation) or another appropriate conductor preparation compound to the brushed surfaces.
- b. Prepare the conductors using established procedures and clamp them in their respective connectors.

For other types of connector, follow the manufacturer's recommended preparation procedure before connecting to Omni-Rupter terminal pads.

[■] "Mass anode" type connectors, such as the Catalog Number 5300 series offered by S&C, which have been designated by the connector manufacturer as being suitable for direct attachment to copper alloy terminal pads.

Installation

Step 15

Attach the jumper connectors to their respective terminal pads using flexible-conductor connections. When attaching connectors to the Omni-Rupter terminal pads, the connectors should be parallel to the terminal pad. Attach and form the conductors so that no significant loading pressure is applied to the terminal pads. See Figure 19.

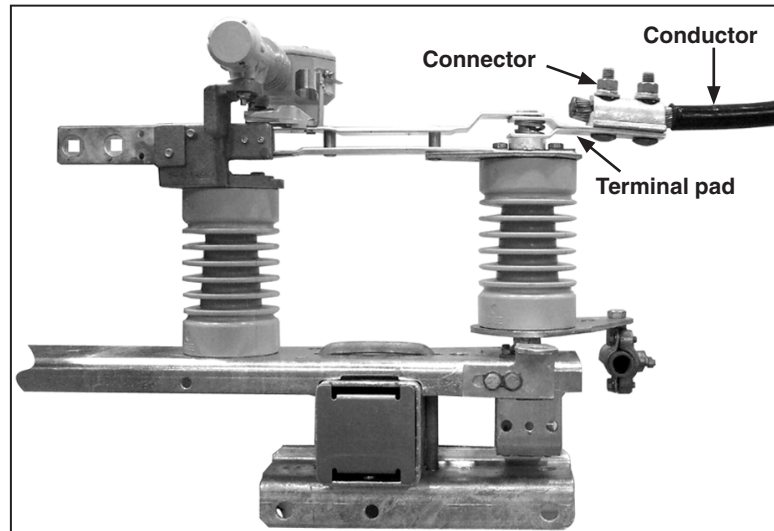

Figure 19. Connect jumper connector parallel to terminal pad.

Before Starting

To manipulate the hookstick mechanism, use a conventional insulated hookstick or S&C Universal Pole and Pole Extension (if required) fitted with a heavy-duty hook-tool such as the S&C Substation Prong or equivalent.

Step 16

Using vigorous downward force, pull the appropriate “hook” of the hookstick mechanism through the full operating stroke of the switch without hesitation at any point. Be prepared to apply additional force to maintain full speed when operating effort increases as the switch blades engage the interrupters. See Figure 20. At the end of the opening or closing stroke, tension should be felt in the hookstick mechanism as the switch moves into its over toggle position.

⚠ WARNING

DO NOT operate the Omni-Rupter switch slowly, “partway,” or use a “chopping” motion when operating the switch.

When in service, the Omni-Rupter switch should always be opened or closed vigorously through its full travel without hesitation at any point.

Partial or slowspeed opening or closing of an energized Omni-Rupter switch may cause unnecessary arcing which will damage the interrupter and blade contacts.

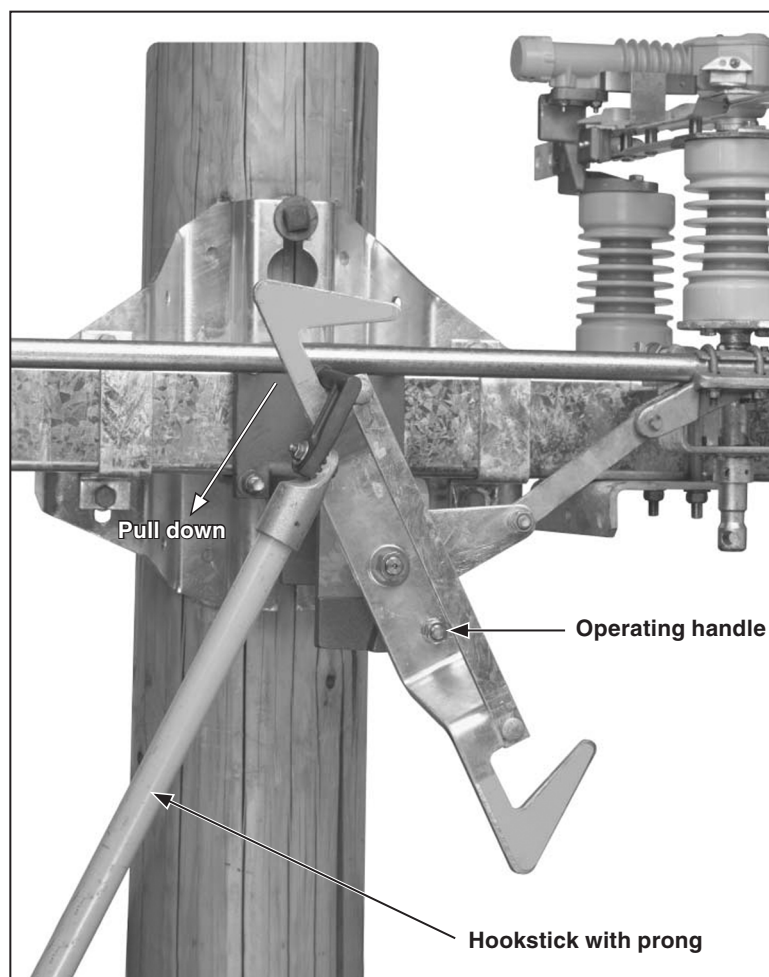

Figure 20. Firmly pull operating handle with hookstick.

