

Installation

Table of Contents

Section	Page	Section	Page
Introduction		Packing and Inspection	
Operating Considerations	2	Packing	7
Qualified Persons	2	Inspection	7
Read this Instruction Sheet	3	Installation	
Retain this Instruction Sheet.	3	Operating Pipe Preparation	8
Proper Application	3	Mounting to Wood	8
Warranty	3	Mounting the Switch Upright.	8
Safety Information		Mounting the Switch Triangular.	10
Understanding Safety-Alert Messages	4	Installing the Optional Pole Band	10
Following Safety Instructions	4	Installing the Vertical Operating Pipe	11
Replacement Instructions and Labels.	4	Installing the Operating Handle	13
Location of Safety Labels	5	Installing the Wildlife Protection Option	15
Safety Precautions.	6	Dead-Ending Conductors	19
		Connecting High-Voltage Conductors.	19
		Locking the Operating Handle	21
		Checking Operation	23

▼ For installation instructions for Omni-Rupter Switches with Catalog Number Supplement “R4,” please refer to your local S&C Sales Office. These instructions are also available on www.sandc.com.

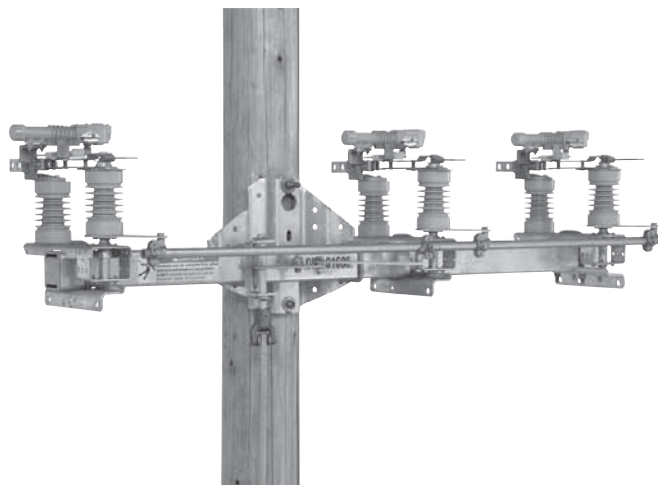

Operating Considerations

CAUTION

The equipment covered by this publication must be selected for a specific application and it must be installed, operated, and maintained by qualified persons who are thoroughly trained and who understand any hazards that may be involved. This publication is written only for such qualified persons and is not intended to be a substitute for adequate training and experience in safety procedures for this type of equipment.

In most applications, these interrupter switches are capable of switching rated continuous load currents at full voltage. Consequently, no interlocking with secondary protective equipment is required.

Circuit making and breaking is involved in the normal operation of these interrupter switches and, as a result, precautionary “partway” opening or closing is undesirable. To operate, swing the operating handle through its full stroke without hesitation. Do not assume that the operating-handle position necessarily indicates the open or closed position of the interrupter-switch blades. Upon completion of an opening or closing operation, visually check the position of the interrupter-switch blades to determine that the intended position has been attained. Then tag or padlock the operating handle in accordance with standard system operating procedures. In all cases make certain that the operating handle is locked before “walking away.” **Note:** These interrupter switches are not intended for breaking fault currents.

Qualified Persons

WARNING

The equipment covered by this publication must be installed, operated, and maintained by qualified persons who are knowledgeable in the installation, operation, and maintenance of overhead electric power distribution equipment along with associated hazards. A qualified person is one who is trained and competent in:

- The skills and techniques necessary to distinguish exposed live parts from nonlive parts of electrical equipment.
- The skills and techniques necessary to determine the proper approach distances corresponding to the voltage to which the qualified person will be exposed.
- The proper use of the special precautionary techniques, personal protective equipment, insulating and shielding materials, and insulated tools for working on or near exposed energized parts of electrical equipment.

These instructions are intended only for such qualified persons. They are *not* intended to be a substitute for adequate training and experience in safety procedures for this type of equipment.

**Read this
Instruction Sheet**

NOTICE

These instructions are for Omni-Rupter Switches with Catalog Number Supplement “R3” and earlier. For installation instructions for Omni-Rupter Switches with Catalog Number Supplement “R4,” please refer to your local S&C Sales Office. These instructions are also available on www.sandc.com.

Thoroughly and carefully read this instruction sheet before installing or operating your S&C Omni-Rupter Switch. Familiarize yourself with “SAFETY INFORMATION” on pages 4 and 5.

**Retain this
Instruction Sheet**

This instruction sheet is a permanent part of your S&C Omni-Rupter Switch. Designate a location where you can easily retrieve and refer to this publication.

Proper Application

⚠ CAUTION

The equipment in this publication must be selected for a specific application. The application must be within the ratings furnished for the equipment. Refer to S&C Specification Bulletin 765-31 for complete application information.

Warranty

The standard warranty contained in S&C’s standard conditions of sale, as set forth in Price Sheet 150, is applicable to the S&C Omni-Rupter Switch covered in this instruction sheet except when it is power operated using a switch operator of other than S&C manufacture.

Safety Information

Understanding Safety-Alert Messages

There are several types of safety-alert messages which may appear throughout this instruction sheet as well as on labels and tags attached to the Omni-Rupter Switch. Familiarize yourself with these types of messages and the importance of the various signal words, as explained below.

DANGER

“DANGER” identifies the most serious and immediate hazards which *will likely* result in serious personal injury or death if instructions, including recommended precautions, are not followed.

WARNING

“WARNING” identifies hazards or unsafe practices which *can* result in serious personal injury or death if instructions, including recommended precautions, are not followed.

CAUTION

“CAUTION” identifies hazards or unsafe practices which *can* result in minor personal injury or product or property damage if instructions, including recommended precautions, are not followed.

NOTICE

“NOTICE” identifies important procedures or requirements that, if not followed, *can* result in product or property damage if instructions are not followed.

Following Safety Instructions

If you do not understand any portion of this instruction sheet and need assistance, contact your nearest S&C Sales Office or S&C Authorized Distributor. Their telephone numbers are listed on S&C’s website www.sandc.com. Or call S&C Headquarters at (773) 338-1000; in Canada, call S&C Electric Canada Ltd. at (416) 249-9171.

NOTICE

Thoroughly and carefully read this instruction sheet before operating your S&C Omni-Rupter Switch.



Replacement Instructions and Labels

If you need additional copies of this instruction sheet, contact your nearest S&C Sales Office, S&C Authorized Distributor, S&C Headquarters, or S&C Electric Canada Ltd.

It is important that any missing, damaged, or faded labels on the equipment be replaced immediately. Replacement labels are available by contacting your nearest S&C Sales Office, S&C Authorized Distributor, S&C Headquarters, or S&C Electric Canada Ltd.

Location of Safety Labels

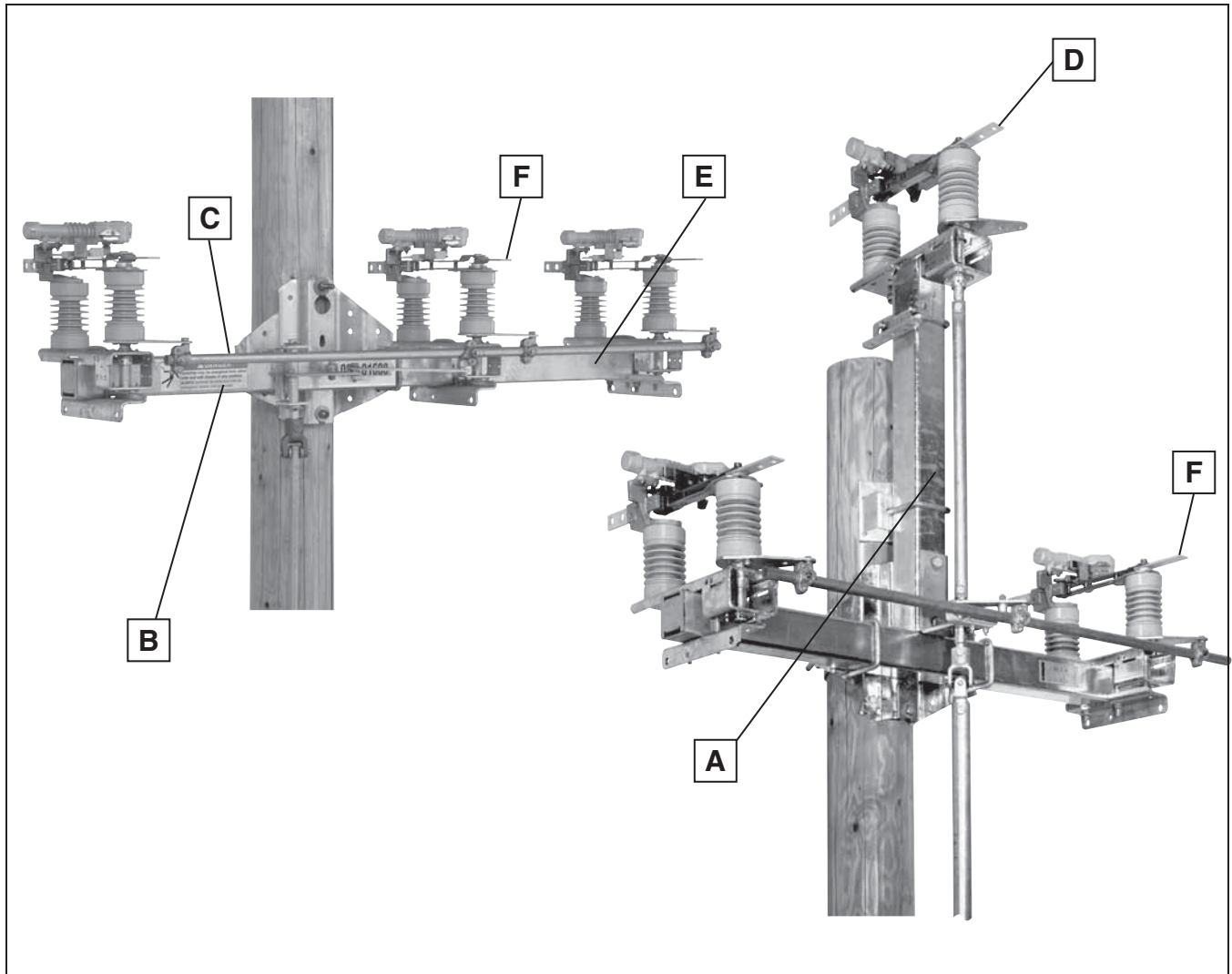

REORDER INFORMATION FOR SAFETY LABELS

Location	Safety Alert Message	Description	Number
A	⚠ DANGER	Switches may be energized from either side and with blades in any position.	G-6580-1★
B	⚠ DANGER	Switches may be energized from either side and with blades in any position.	G-6580-2★
C	⚠ WARNING	Lifting Instructions	G-5928R3▲
D	⚠ WARNING	Lifting Instructions	G-10030▲
E	NOTICE	Do not remove this lifting bracket until . . .	G-4776R1▲
F	NOTICE	To avoid overloading the terminal pads . . .	G-9094▲

★ This label is placed on both sides of switch base on opposite ends.

▲ This part is a tag which is to be removed and discarded after the switch is installed and adjusted.

⚠ DANGER



Omni-Rupter Switches operate at high voltage. Failure to observe the precautions below will result in serious personal injury or death.

Some of these precautions may differ from company operating procedures and rules. Where a discrepancy exists, users should follow their company's operating procedures and rules.

1. **QUALIFIED PERSONS.** Access to switches and controls must be restricted only to qualified persons. See "Qualified Persons" on page 2.
2. **SAFETY PROCEDURES.** Always follow safe operating procedures and rules.
3. **PERSONAL PROTECTIVE EQUIPMENT.** Always use suitable protective equipment such as rubber gloves, rubber mats, hard hats, safety glasses, and flash clothing in accordance with safe operating procedures and rules.
4. **SAFETY LABELS AND TAGS.** Do not remove or obscure any of the "DANGER," "WARNING," "CAUTION," or "NOTICE," labels and tags. Remove tags **ONLY** if instructed to do so.
5. **ENERGIZED COMPONENTS.** Always consider all parts live until de-energized, tested, and grounded.
6. **LOAD-INTERRUPTER SWITCH POSITION.** Always confirm the open/close position of load-interrupter switches by visually observing the position of the blades. Switches may be energized from either side and with the blades in any position.
7. **MAINTAINING PROPER CLEARANCE.** Always maintain proper clearance from energized components.
8. **OPERATION.** Circuit making and breaking is involved in the normal operation of this interrupter switch and, as a result, "partway" opening or closing is undesirable. To operate, swing the operating handle through its full travel vigorously and without hesitation. See "Checking Operation" on page 23.

Packing

Study the erection drawing carefully and check the bill of material to be sure that all parts are at hand. Standard Minor Modification parts are shown on the bill of material under the suffix specified: “-S1,” “-S2,” “-S6,” “-S6L,” “-V1,” “-V2,” or “-V3.”

When a Standard Mounting Arrangement is specified, the shipment will include:

1. A **three-pole interrupter switch**, complete with interphase drive, factory-assembled on a single base. (Upright-mounted or triangular-mounted.)
2. Four 6' 10" **vertical-operating pipe sections**, predrilled, where required, for attachment to the universal couplings.
3. Miscellaneous **mounting hardware** (less through-bolts) for securing the Omni-Rupter switch to the pole.
4. The appropriate set of **operating-mechanism components** for the vertical operating pipe; e.g. handle, guide bearings, and couplings—each tagged and keyed to the bill of material for ready identification.
5. If a **Standard Minor Modification** of a Standard Mounting Arrangement is specified, the appropriate parts, as identified in the bill of materials under suffix : “-S1,” “-S2,” “-S6,” or “-S6L” will be included with the operating-mechanism components. Specifically, the modifications designated by these suffixes are:
 - S1 One tubular fiberglass insulating section in vertical operating shaft.
 - S2 One Cypoxy® Insulator unit in vertical operating shaft.
 - S6 Key interlock—single lock for “locked open” application.
 - S6L Provisions only for key interlocks—mounting bracket for interlock.“-V1,” “-V2,” or “-V3”—adds (one, two, or three respectively) extra 6' 10" lengths of pipe and includes the appropriate number of extra couplings and guides.
6. A **detailed erection drawing** (ED) for the Omni-Rupter will be found in a water-resistant envelope shipped with the switch. If a Standard Mounting Arrangement is to be used, this erection drawing is a printed sheet. This same sheet is also furnished when a Standard Minor Modification of a Standard Mounting Arrangement is to be used. In the latter case, a copy of RD-3469 (Standard Minor Modifications, Rotating-Type and Reciprocating-Type Operating Mechanisms) is included.

Drawings for Standard Mounting Arrangements show only minimum or suggested locating dimensions for the vertical-operating-pipe guide bearings and the operating-handle assembly. Specific locations are to be determined either on the job or by the user's engineering department.

Inspection

Examine the shipment for external evidence of damage as soon after receipt as possible, preferably before removal from the carrier's conveyance. Check the bill of lading to make sure that shipping skids, crates, and containers listed thereon are present:

If there is visible loss and/or damage:

1. Notify the delivering carrier immediately.
2. Ask for a carrier inspection.
3. Note condition of shipment on all copies of the delivery receipt.
4. File a claim with the carrier.

If concealed damage is discovered:

1. Notify the delivering carrier within 15 days of receipt of shipment.
2. Ask for a carrier inspection.
3. File a claim with the carrier.

Also notify S&C Electric Company in all instances of loss and/or damage.

Each integer style Omni-Rupter switch is factory-assembled on a common base. All switch adjustments, including those of the interphase drive, are made at the factory to ensure proper switch operation during opening and closing. Ease of installation is assured by following these step-by-step instructions.

Installation

Operating Pipe Preparation

If desired, the vertical operating pipe can be cut to length (if not pre-cut at the factory) before proceeding to the job site. The standard lengths of pipe supplied measure 6'-10". Cutting dimensions are shown on the erection drawing.

Mounting to Wood

When mounting the switch and its operating mechanism to a wood pole, it is recommended that suitably sized square washers be placed under the nuts. The use of spring-type washers between the square washers and nuts is also recommended to compensate for wood-pole shrinkage and thus maintain fastener tightness.

Step 1

Drill two $\frac{1}{16}$ -inch diameter holes in the utility pole at the desired height for mounting the switch. Refer to the erection drawing for details.

Step 2

Insert two $\frac{5}{8}$ -inch diameter through-bolts (not furnished) in the holes drilled in Step 1 and secure loosely with the necessary square washers and nuts in such a manner that the heads of the bolts project sufficiently from the face of the pole to engage the switch-base mounting bracket.

Mounting the Switch—Upright Mounting Configuration

Step 3

WARNING

Lift the switch using the lifting brackets provided. Do not allow lifting slings to stress switch parts. Avoid allowing switch to swing while lifting.

Lifting the switch by the live parts or pole-unit bases will damage the switch. Rough handling may cause misalignment of the blades and contacts.

Failure to lift the switch properly can result in switch damage, causing improper operation, arcing or electrical shock.

NOTICE

DO NOT remove the lifting brackets until the switch has been lifted into place and bolted to the pole.

Switches in the upright mounting configuration are provided with two lifting brackets bolted to a 4"×4" wood support member which is, in turn, attached to the switch base. See Figure 1. Since the wood support member is also a part of the shipping skid, use care to avoid damage to it during unpacking.

- a. Make sure that the switch is fully closed.
- b. Attach lifting slings **ONLY** to the lifting brackets bolted to the wooden support members.
- c. Lift the switch as shown in Figure 1 until the lifting slings are just taut.
- d. Unbolt the wooden supports from the shipping skid.
- e. Slowly and carefully lift the switch to the proper mounting height.
- f. Guide the switch so that the through bolts projecting from the utility pole slip into the holes in the switch's pole-saddle. (The pole-saddle is provided with a keyhole and an open slotted-hole for ease of installation.)
- g. Lower the switch so that the pole-saddle bears down on the through bolts.
- h. Securely tighten the through-bolts.
- i. Remove wooden supports and lifting brackets.

If desired, a crossarm brace (user-furnished) may be attached to the base. Mounting brackets for crossarm braces must be specified separately. Contact your local S&C Sales Office for details

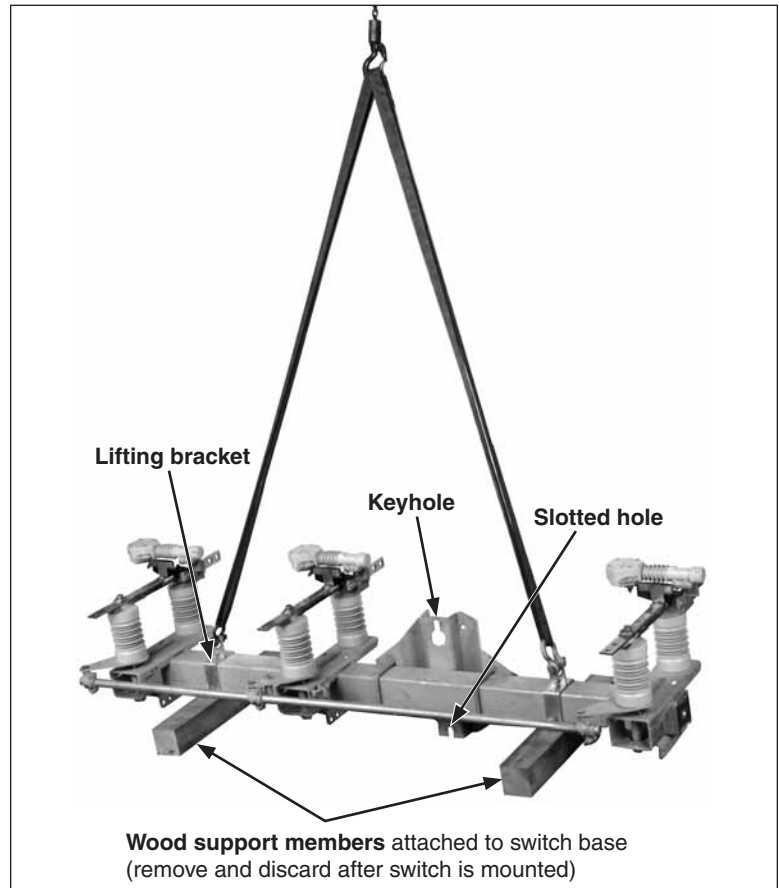

Figure 1. Hoisting upright mounting configuration Omni-Rupter switch into position.

Mounting the Switch—Triangular Mounting Configuration

⚠ WARNING

Lift the switch using the lifting brackets provided. Do not allow lifting slings to stress switch parts. Avoid allowing switch to swing while lifting.

Lifting the switch by the live parts or pole-unit bases will damage the switch. Rough handling may cause misalignment of the blades and contacts.

Failure to lift the switch properly can result in switch damage, causing improper operation, arcing or electrical shock.

- Make sure that the switch is fully closed.
- Attach lifting slings **ONLY** to the vertical switch support member by looping around the dead-ending bracket and the switch mounting weldment.
- Lift switch as shown in Figure 2 until the lifting slings are just taut.
- Unbolt the wooden supports from the shipping skid.
- Slowly and carefully lift the switch to the proper mounting height.
- Guide the switch so that the through bolts projecting from the utility pole slip into the holes in the switch's pole-saddle. (The pole-saddle is provided with a keyhole and an open slotted-hole for ease of installation.)
- Securely tighten the through-bolts.
- Remove the lifting slings from the switch.

Installing the Optional Pole Band

Step 4

Secure the pole-band (optional) to the mounting bracket on the switch, using the J-bolts provided. See Figure 3. Two ¼" × 1" × 3" stiffening blocks are furnished to be used behind the pole-band flanges, and underneath the J-bolt nuts. Lag the pole band to the back side of the pole through the hole in the center of the band, using one of the three ½-inch diameter lag screws provided. Then, lag the mounting bracket to the pole using the two remaining ½-inch lag screws as shown in Figure 3.

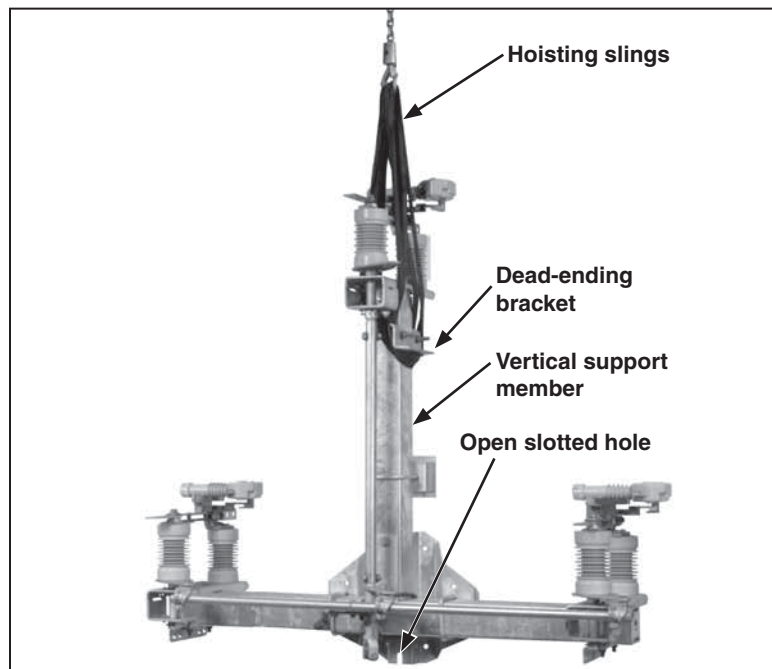

Figure 2. Hoisting Omni-Rupter switch into position for triangular mounting configuration.

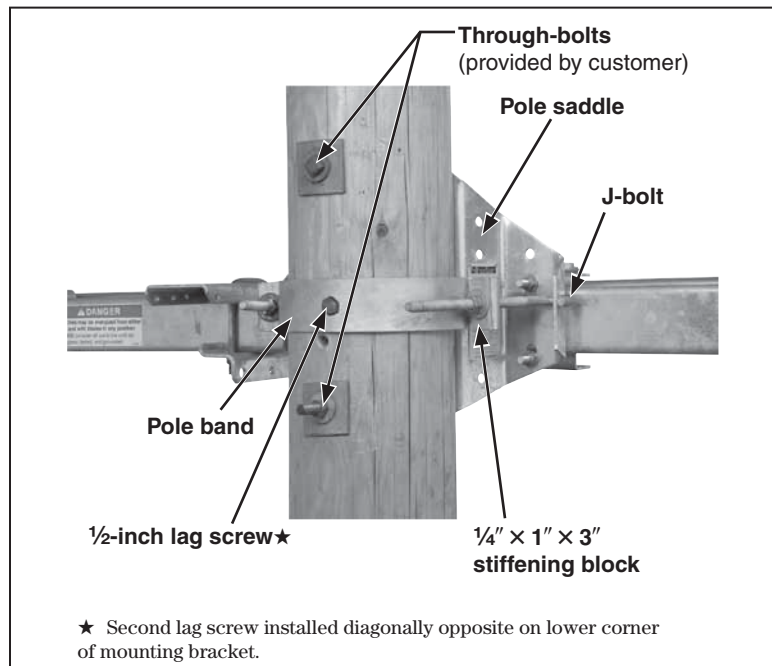

Figure 3. Typical pole-band attachment detail (upright mounting configuration illustrated).

If desired, a crossarm brace (user-furnished) may be attached to the base for switches in the upright mounting configuration. Mounting brackets for crossarm braces must be specified separately. Consult your nearest S&C Sales Office for details.

Installing the Vertical Operating Pipe

Step 5

S&C recommends making up each coupling as work progresses. When installing operating pipe in a rigid coupling, make certain that the cutting tip of the piercing set screw does not protrude through the body of the coupling. Torque the clamp bolt to final tightness. Then, tighten the piercing set screw, piercing the pipe, and continue turning until a firm resistance is felt.

NOTICE

Installing Piercing Set Screws

This equipment uses piercing set screws to couple the operating mechanism to the operating pipe, and to provide stability to couplings joining one or more lengths of pipe.

Before assembling a coupling, back the piercing set screw out of the coupling so that the tip does not protrude into the body of the coupling. This ensures that the coupling's clamp screws can be fully-tightened.

After tightening the clamp bolts to their final torque, tighten the set screws to pierce and/or crimp the pipe.

Step 6

Locate the universal coupling that is shipped in the carton of switch ED parts. Attach the universal coupling to the rotating shaft of the toggle mechanism using the 1/2-inch stainless-steel pin, flatwasher, and cotter pin provided. See Figure 4 or 5, as applicable. Install the uppermost section of predrilled vertical operating pipe on the universal coupling as shown. Then, secure the vertical operating pipe to the universal coupling using the 1/2—13 × 2 1/2 bolt, flatwasher, and nut provided. *If only one vertical pipe section is used, omit Steps 6 through 9 and proceed to Step 10.*

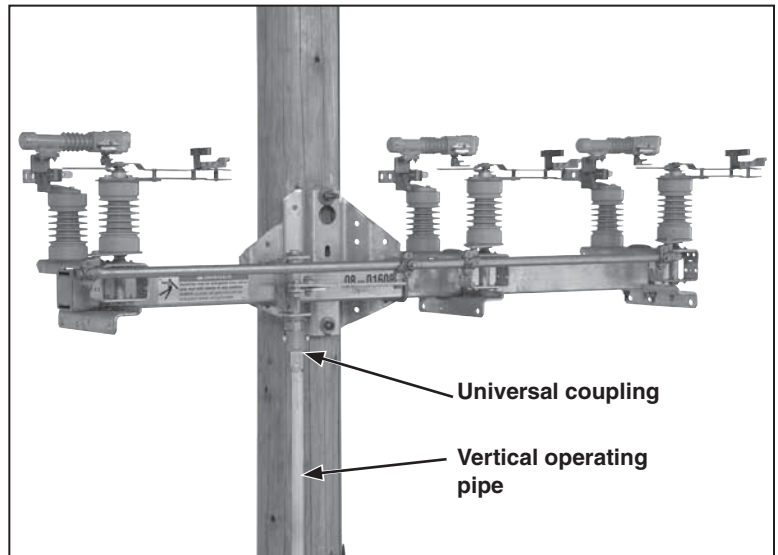

Figure 4. Attaching uppermost vertical operating pipe to switch for upright mounting configuration.

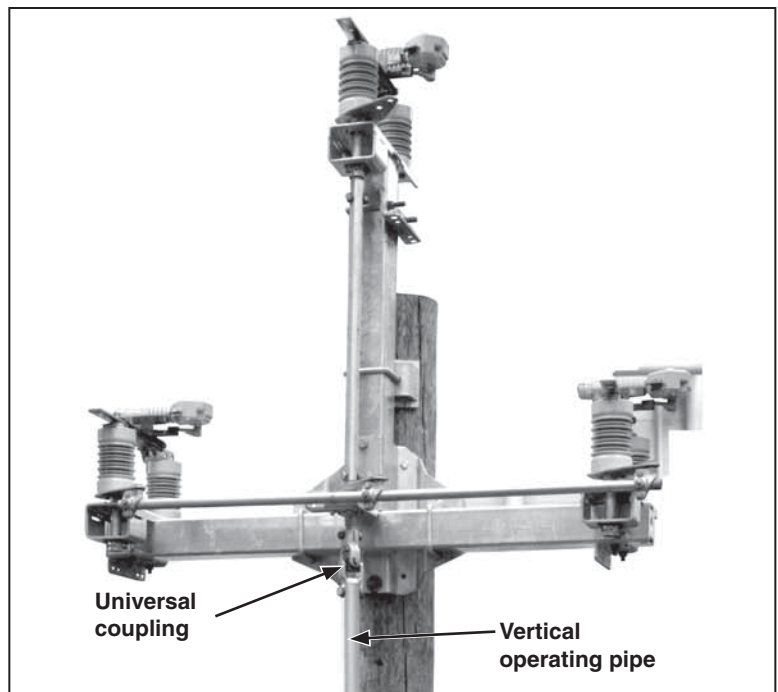

Figure 5. Attaching uppermost vertical operating pipe to switch for triangular mounting configuration.

Installation

Step 7

Install a universal coupling on the lower end of the uppermost section of vertical operating pipe in the fashion described above, using the $\frac{1}{2}$ —13 \times 2 $\frac{1}{2}$ bolt and $\frac{1}{2}$ —13 nut provided. See Figure 6.

Step 8

Position and install the guide bearing assembly on the pole in accordance with the dimension shown on the erection drawing.

Step 9

Pass the next section of vertical operating pipe up through the guide bearing and attach it to the universal coupling on the lower end of the uppermost vertical-operating-pipe section. See Figure 6.

Step 10

Repeat Steps 7 and 8 if additional sections of vertical operating pipe and guide bearing assemblies are specified. These additional sections of vertical operating pipe will be joined with rigid couplings rather than universal couplings. See Figure 7. Make certain the cutting tips of the piercing set screws in the rigid coupling do not protrude through the body of the coupling when inserting sections of vertical operating pipe into the coupling. After the pipe is in place, torque the clamp bolts to final tightness; then tighten the associated piercing set screws, piercing the pipe, and continue turning until a firm resistance is felt.

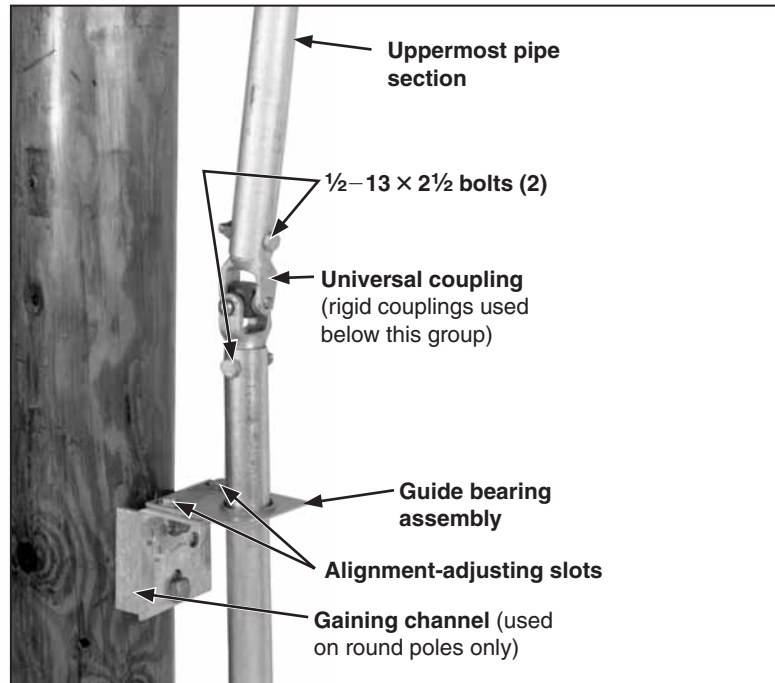

Figure 6. Guide bearing assembly and universal coupling (upper position).

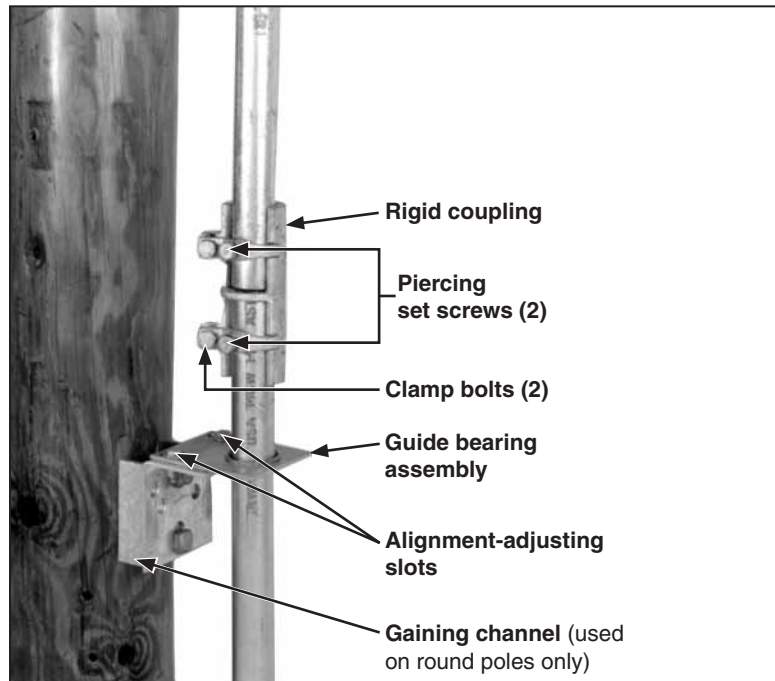

Figure 7. Guide bearing assembly and rigid coupling (intermediate positions).

Installing the Operating Handle

Step 11★

Install the operating-handle assembly on the lowest section of vertical operating pipe at the location indicated on the erection drawing. Make certain the cutting tip of the piercing set screw in the operating-handle assembly does not protrude through the clamp when installing the assembly on the vertical operating pipe. After the operating-handle assembly is in place, tighten the piercing set screw on the operating-handle assembly, piercing the pipe, and continue turning until a firm resistance is felt. See Figure 8.

Slide the foot bearing assembly onto the lowest vertical-operating-pipe section and bolt it to the pole at the position shown on the erection drawing. At the same time, use one of the mounting bolts to attach one end of the grounding strap (the end with the grounding connector attached) to the foot bearing assembly.▲

If necessary to compensate for the taper of the wood pole, and to keep the vertical operating pipe aligned and plumb, shift the guide bearings toward or away from the pole. Alignment slots are provided for this purpose. See Figures 6 and 7.

Step 12

Fasten the free end of the grounding strap to the lowest vertical-operating-pipe section a few inches above the operating-handle assembly (or key interlock) with the U-bolt connector provided for this purpose. *Then connect the lower end of the strap to a suitable earth ground, fusing the grounding connector provided at that end of the strap.*▲ See Figure 8.

Step 13

Open and close the interrupter switch slowly to see that no operating difficulties are encountered due to undetected damage in shipping. (This applies only when checking for alignment and complete closure; when in service the interrupter switch should be opened or closed vigorously through its full travel without hesitation at any point. Be prepared to apply additional force to maintain full speed when operating effort increases as the switch blades engage the interrupters.)

★ When a key interlock is furnished (Standard Minor Modification Suffix “-S6”), refer to Step 21 at this point.

▲ The grounding recommendations herein may differ from the standard operating and safety procedures of certain electric utility companies. Where a discrepancy exists, the operating procedures of the electric utility apply.

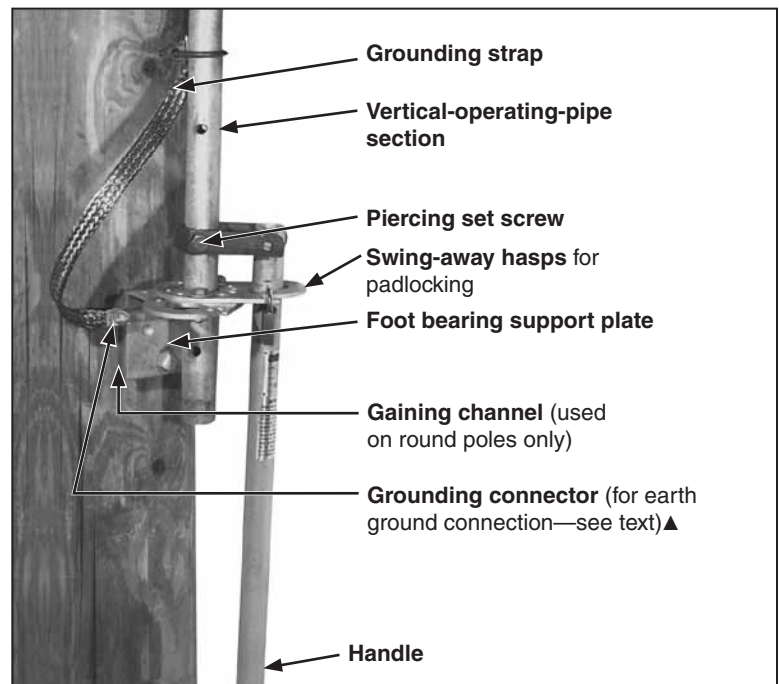

Figure 8. Foot bearing assembly and operating-handle assembly.

Step 14

⚠ CAUTION

Adjust the stop plates to remove all excess play from the operating mechanism and to attain proper “windup” tension before energizing the switch.

Slack in the operating pipe may allow the switch to creep out of the fully-closed position.

Failure to properly adjust the handle may cause contact overheating or arcing, damaging the blade contacts. Injury to operating personnel may result.

Loosen the bolts which secure the adjustable stop plates to the foot bearing support plate. See Figure 9. Place the switch in the fully-open position and adjust the open-position stop plate so that the handle, when lowered, fits into the open-position slot. Mark, on the support plate, the location of the open-position stop plate.

Fully close the switch and apply sufficient pressure to the handle in the closing direction to remove all play in the operating-pipe linkage. Now adjust the closed-position stop plate so that the handle will require even greater pressure to force it into the closed-position slot. Mark, on the support plate, the location of the closed-position stop plate.

While holding both stop plates in the previously marked positions, torque the bolts to secure the stop plates to the support plate. Move the handle to the switch-open position and verify that the handle, when lowered, fits firmly into the open-position slot.

Then move the handle to the switch-closed position. Verify that all play in the operating-pipe linkage has been taken up before the handle can be lowered into the closed-position slot and, further, that substantial pressure is required to force the handle into the closed-position slot. Attainment of this “windup” tension in the operating linkage is essential to ensure positive switch closure.

Step 15

Recheck to be sure that all clamp bolts and piercing set screws have been torqued to final tightness.

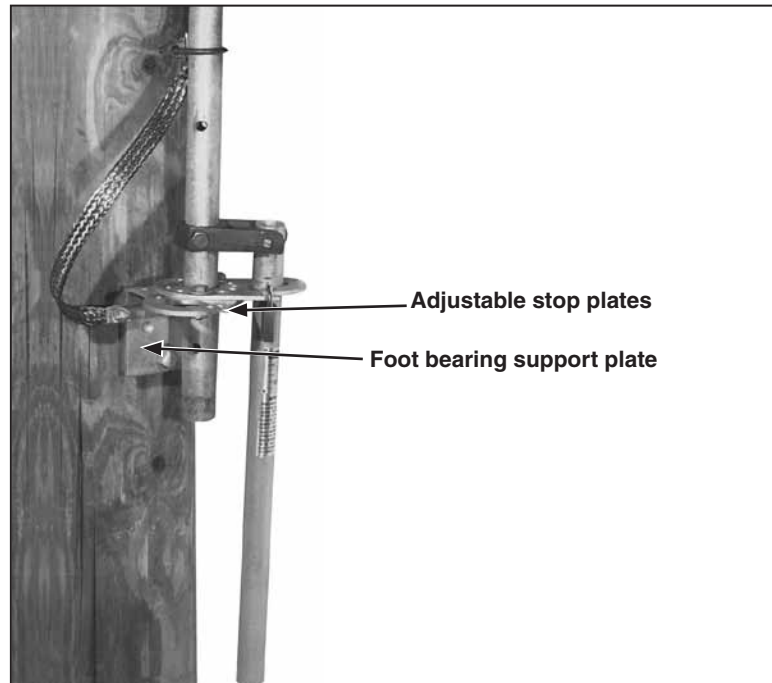

Figure 9. Foot bearing assembly and operating-handle assembly.

Installing the Wildlife Protection Option (Catalog Number Suffix “-W”)

⚠ DANGER

De-energize the switch and ground it at all six terminals before installing the wildlife protection option.

The wildlife protection option is not designed to be installed on energized equipment.

Failure to do so could lead to serious injury or death.

The wildlife protection option helps prevent climbing and perching animals from making phase-to-grounded part contact. See Figure 10. A typical wildlife protection installation includes:

- Two base covers (three base covers on switches with extra mounting-pole clearance.) (Base covers are not included on switches with insulated bases.)
- Six wildlife disks.
- One pole-saddle cover (not included when switch with extra mounting-pole clearance is specified), pre-installed.
- One fiberglass interphase operating rod, pre-installed.

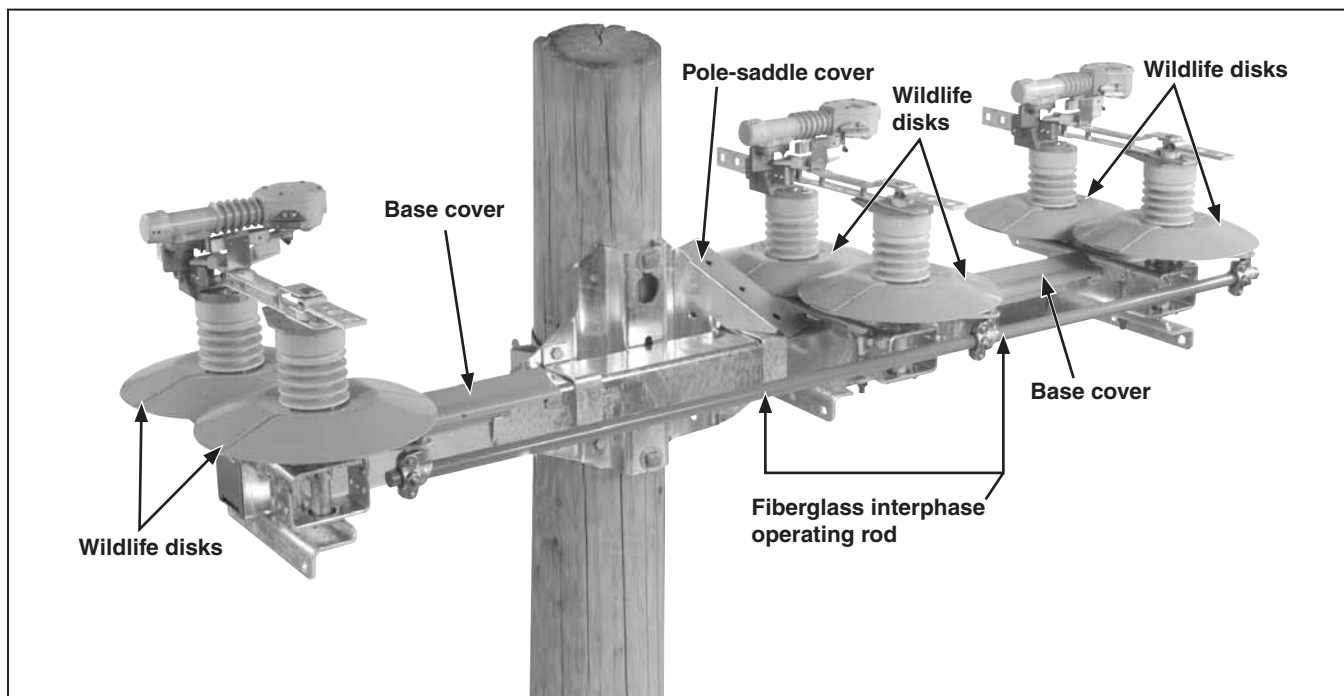

Figure 10. 14.4-kV Omni-Rupter with Optional Wildlife Protection (Catalog Number Suffix “-W”), Upright Mounting Configuration.

NOTICE

S&C recommends installing the wildlife protection option after the switch is secured to the utility pole.

Damage to the wildlife option may occur if lifting slings strain the wildlife disks during handling.

In Figure 10 on page 15, a typical installation of the wildlife protection option is illustrated. The pole-saddle cover will be pre-installed at the factory, as will the fiberglass interphase operating rod. Consult the RD drawing accompanying the switch installation instructions for details specific to your switch that may differ from the instructions below. Following are instructions for a typical field installation of the wildlife protection option.

Step 16

Installing the Base Covers:

With the switch in the closed position, place the base covers onto the steel base of the switch in the positions shown on the associated RD drawing. If optional surge arrester mounting provisions (Catalog Number Suffix “-A1” or “-A2”) have been specified for the switch, cutouts will be provided in the base covers to fit around the arrester mounting brackets.

Step 17

Hook one end of the spring clip assembly into the lip on the edge of one side of the base cover. See Figure 11. Bring the spring clip underneath the switch base and stretch it until it can be hooked into the lip on the edge of the opposite side of the base cover. Make sure the spring clip is at least one-half inch from the edge of the base cover. See Figure 12. Install the remaining spring clips on their respective base covers in accordance with the supplied RD drawing.

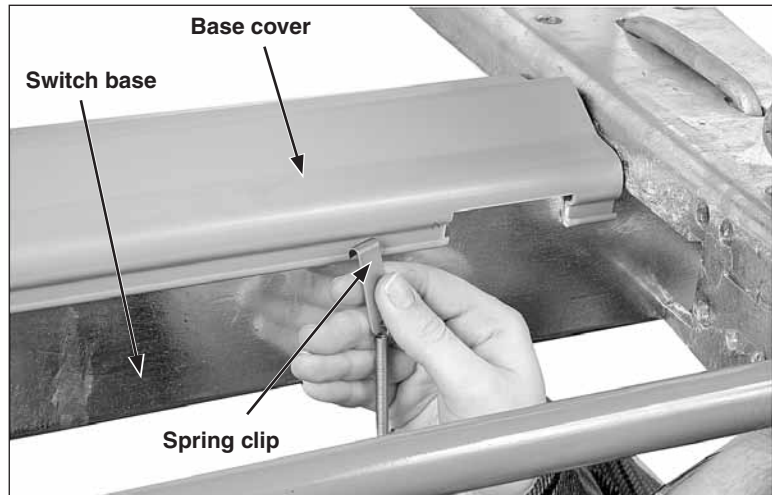

Figure 11. Hook one end of spring clip into base cover lip. Stretch underneath base and hook on opposite side.

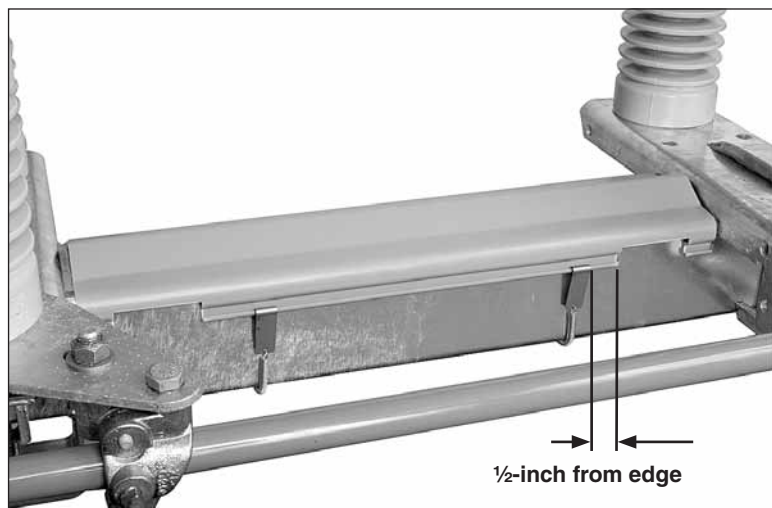

Figure 12. Make sure clips are installed 1/2-inch from edge of cover.

Installing the Wildlife Disks:

Before installing the wildlife disks, determine the proper placement of the disks on the switch blade and contact insulators.

On 14.4-kV Omni-Rupter Switches (Porcelain and Cypoxy® Insulators)

Install the wildlife disk to the bottom skirt root of the insulator on both the blade and contact ends of the switch. When the wildlife disks are properly installed, the disks will overlap slightly as shown in Figure 13.

On 25-kV Omni-Rupter Switches (Porcelain and Cypoxy® Insulators)

Blade-end of the switch: Install the wildlife disk on the bottom skirt root of the insulator.

Contact-end of the switch: Count up two skirts from the base and install the wildlife disk to the insulator on the blade-end. When the wildlife disks are installed properly, they will be at approximately the same height. See Figure 14.

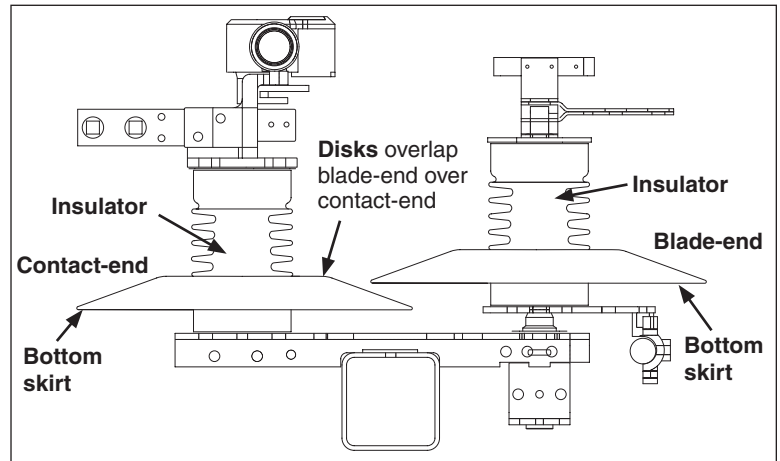

Figure 13. Wildlife disk placement on 14.4-kV Omni-Rupter Switches.

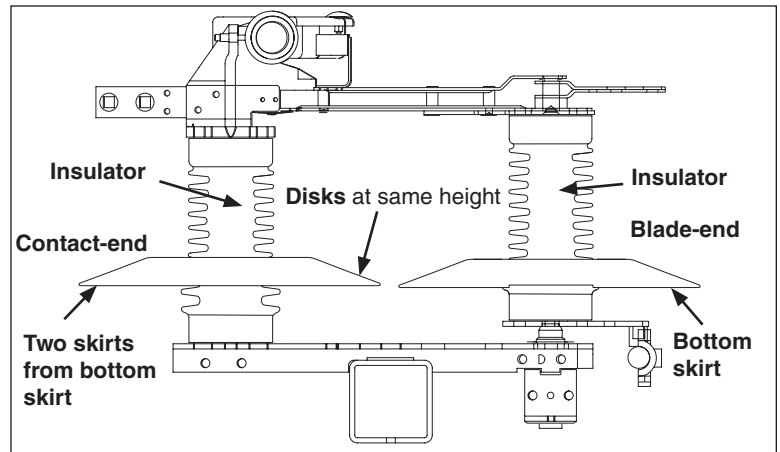

Figure 14. Wildlife disk placement on 25-kV Omni-Rupter Switches.

Step 18

- a. To assemble the disks, fit the disk around the insulator on the blade-end of the switch. See Figure 15. Then, insert the locking tabs of one-half of the disk into the open slot on the other half to create a secure overlapping fit. Repeat the procedure on the opposite side of the disk. When the halves are correctly assembled, the S&C logo will be on top of the disk on both sides. See Figure 16.
- b. Starting with the outside locking tabs first, squeeze the overlapping sides together until the tabs audibly snap into place.
- c. Push the two halves of the disk together in towards the insulator so that it fits the insulator as close as possible. See Figure 17. Snap the upper locking tab firmly into place. Both tabs should protrude through the open slot as shown in Figure 16.
- d. Repeat a. through c. above to install the wild-life disks on the insulators on the contact-end of the switch.

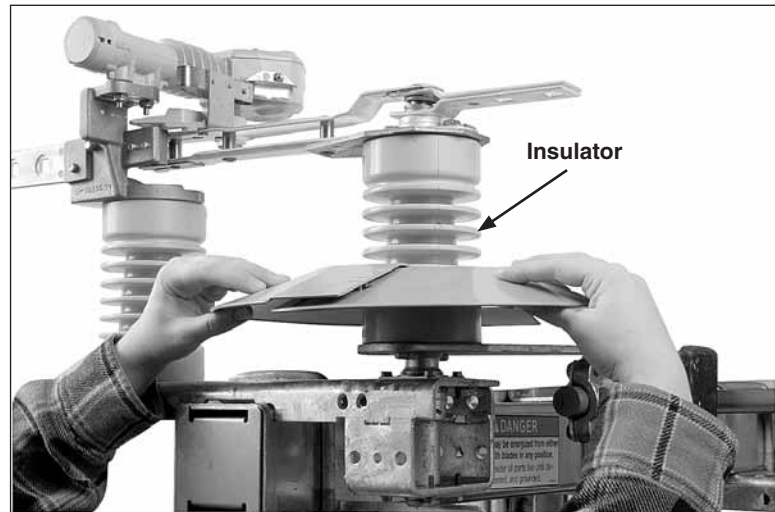

Figure 15. Fit the disk halves around the insulator.

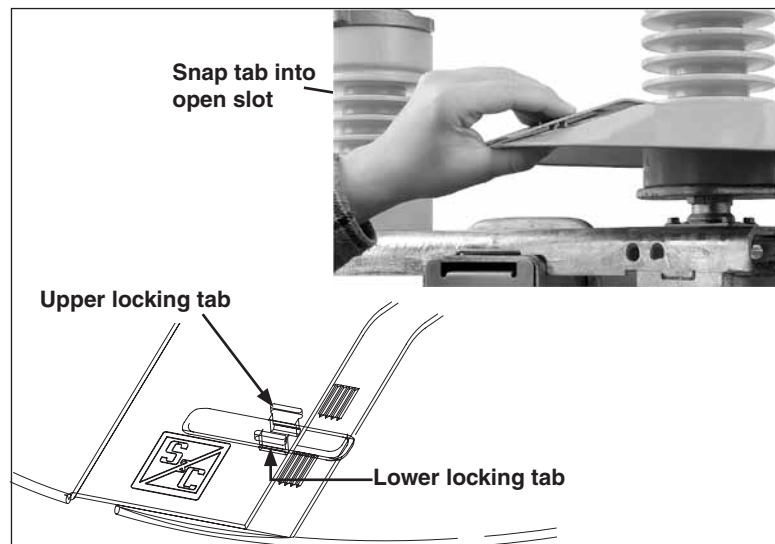

Figure 16. Snap lower tab into open slot.

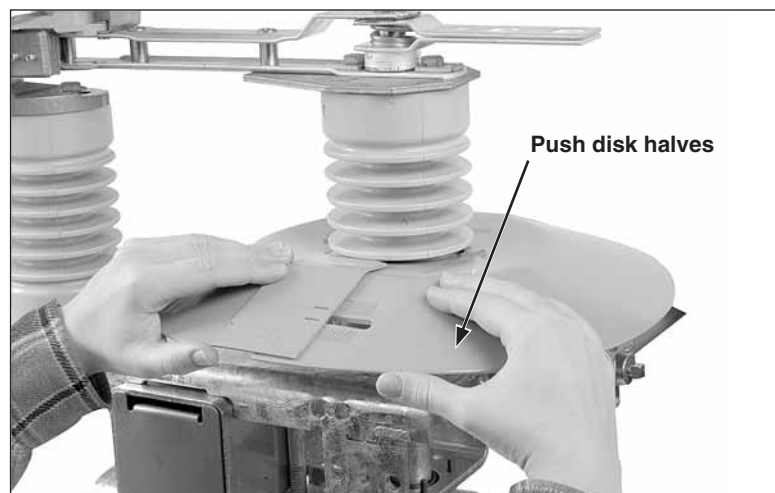

Figure 17. Push disk halves together. Snap upper tab into place. Disk halves should fit as tight against the insulator as possible.

Dead-Ending Conductors

Dead-ending provisions are standard on Omni-Rupter switches that have upright, upright (extra mounting pole clearance), or triangular, mounting configurations. When dead-ending to these brackets, a pole band and extension-link assemblies ♦ are required. See Figure 18.

Maximum dead-end loading for S&C dead-ending brackets on switches with *steel* bases:

- 2000 pounds per conductor where pull-off forces are applied to only one side of the switch.
- 8000 pounds per conductor where equal pull-off forces are applied to both sides of the switch.
- 1500 pounds per conductor for upright switches *with extra mounting pole clearance* where pull-off forces are applied to only one side of the switch.

Maximum dead-end loading for S&C dead-ending brackets on switches with *insulated* bases:

- 750 pounds or 500 pounds per conductor, 14.4-kV and 25-kV respectively, where pull-off forces are applied to only one side of the switch, including upright switches with extra mounting pole clearance.
- 8000 pounds per conductor for 14.4-kV and 25-kV switches, where equal pull-off forces are applied to both sides of the switch.

Connecting High-Voltage Conductors

⚠ DANGER

Conductors must be de-energized and grounded in accordance with standard system operating practice.

Failure to do so can result in serious injury or death.

NOTICE

To avoid overloading the terminal pads, S&C recommends making the jumper connection to the line conductor *before* securing jumper fasteners to the terminal pad.

♦ A pole band can be specified by adding suffix “-P1” to the catalog number. Extension-link assemblies can be provided by adding suffix “-D” to the catalog number of the switch, or equivalent user-furnished extension means may be used.

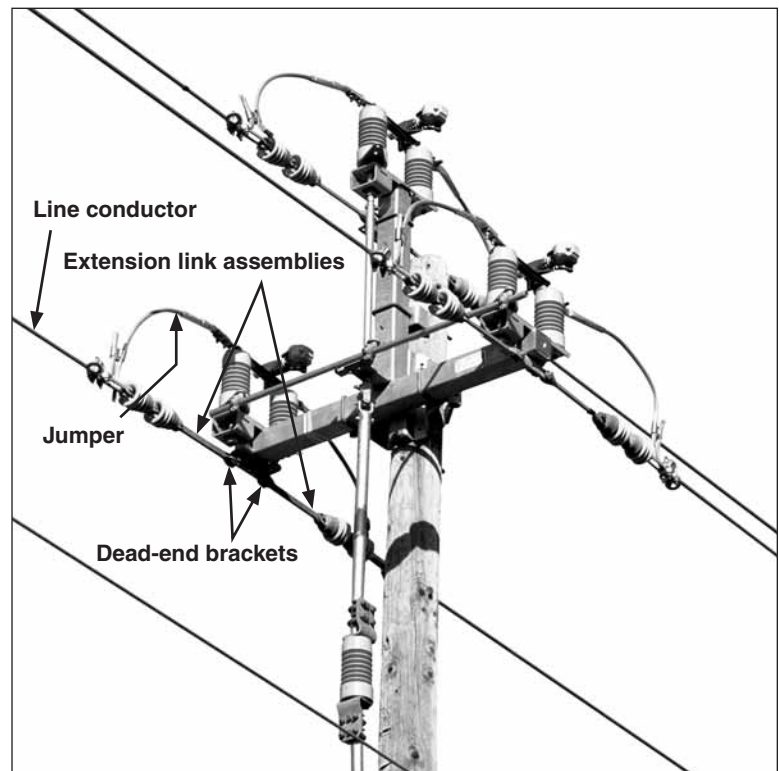

Figure 18. Dead-ending bracket (triangular mounting configuration shown).

Installation

Step 19

The Omni-Rupter terminal pads are silver plated and do not require abrasive cleaning as a part of their preparation. Wipe any dirt or grease from the surface, and apply a thick coating of Penetrox A® or other appropriate conductor preparation compound. **DO NOT** wire-brush the terminal pads. Wire brushing may scratch the plating.

Step 20

When high-voltage conductors are to be connected using aluminum-alloy connectors★, the following procedures should be employed:

- a. Thoroughly wire-brush the current-transfer surfaces of each connector and immediately apply a liberal coating of Penetrox A (available from Burndy Corporation) or another appropriate conductor preparation compound to the brushed surfaces.
- b. Prepare the conductors using established procedures and clamp them in their respective connectors.

For other types of connector, follow the manufacturer's recommended preparation procedure before connecting to Omni-Rupter terminal pads.

⚠ CAUTION

DO NOT apply excessive load to the terminal pads.

The jumper connections should be in-line with and level to the terminal pad bolt holes before securing the jumper fasteners to the terminal pad. Large pull-off forces may misalign the blades with the stationary contacts or prevent proper closing.

Misaligned contacts may overheat causing arcing and damage to the switch. Injury to operating personnel may result.

Step 21

Attach the jumper connectors to their respective terminal pads using flexible-conductor connections. When attaching connectors to the Omni-Rupter terminal pads, the connectors should be parallel to the terminal pad. Attach and form the conductors so that no significant loading pressure is applied to the terminal pads. See Figure 19.

★ "Mass anode" type connectors, such as the Catalog Number 5300 series offered by S&C, which have been designated by the connector manufacturer as being suitable for direct attachment to copper alloy terminal pads.

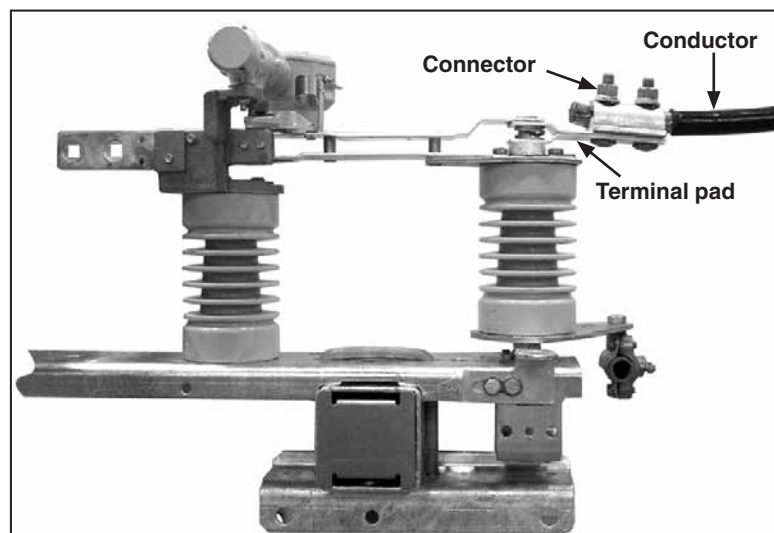

Figure 19. Connect jumper connector parallel to terminal pad.

Locking the Operating Handle

Step 21

With padlock: The operating-handle assembly includes swing-away hasps for padlocking the interrupter switch in either the open or closed position.

With key interlock: The interlock group (see Figure 20) includes a Superior key interlock, Type B6003-1 Mk II single or multiple key (or equivalent), with $\frac{3}{8}$ -inch bolt projection and $\frac{3}{4}$ -inch bolt travel, locking disc, and interlock bracket. If “provision only” for a key interlock is specified, the interlock will not be included. Assemble with the operating-handle assembly as follows:

If necessary to compensate for the taper of the wood pole, and to keep the vertical operating pipe aligned and plumb, shift the guide bearings toward or away from the pole. Alignment slots are provided for this purpose. See Figures 6 and 7 on page 12.

- a. Slide the interlock bracket, locking disc, operating-handle assembly, and foot bearing assembly onto the lowest vertical-operating-pipe section with the locking disc and the operating-handle assembly between the interlock bracket and the foot bearing assembly as illustrated in Figure 20. Bolt the foot bearing assembly to the pole at the position shown on the erection drawing. At the same time, use one of the mounting bolts to attach one end of the grounding strap (the end with the grounding connector attached) to the foot bearing assembly.▲

If necessary to compensate for the taper of the wood pole, and to keep the vertical operating pipe aligned and plumb, shift the guide bearings toward or away from the pole. Alignment slots are provided for this purpose. See Figures 6 and 7 on page 12.

▲ The grounding recommendations herein may differ from the standard operating and safety procedures of certain electric utility companies. Where a discrepancy exists, the operating procedures of the electric utility apply.

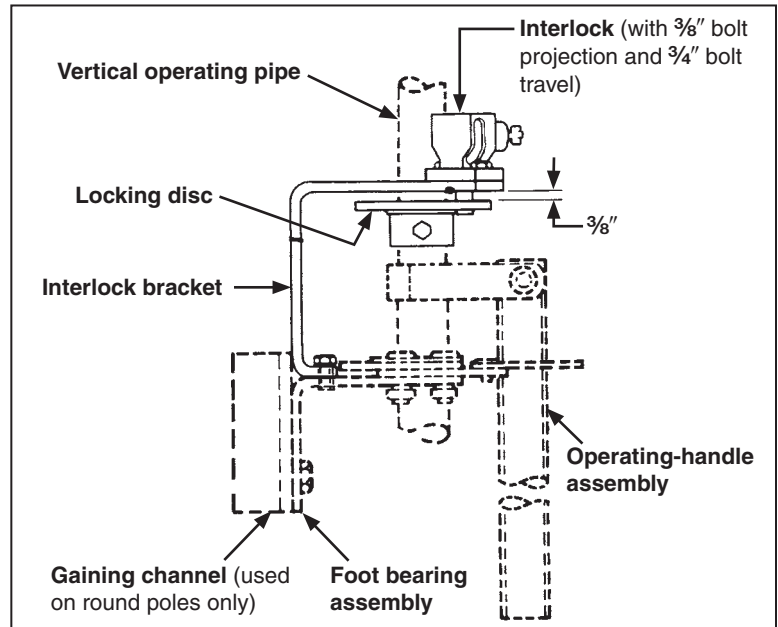

Figure 20. Key-interlock group detail.

Installation

- b. Install the operating-handle assembly on the lowest section of vertical operating pipe at the location indicated in the erection drawing. Make certain the cutting tip of the piercing set screw in the operating-handle assembly does not protrude when installing the assembly on the vertical operating pipe. After the operating handle is in place, tighten the piercing set screw on the operating-handle assembly, piercing the pipe, and continue turning until a firm resistance is felt. See Figure 21.
- c. Attach the interlock bracket to the foot bearing assembly, using the $\frac{1}{2}$ -13 \times 1 screws and lockwashers furnished.
- d. Attach the key interlock to the interlock bracket and extend the bolt.
- e. With the interrupter switch in the closed position, use the interlock bolt to position the locking disc so that the bolt enters the closed-position slot in the disc (and will enter the open-position slot when the switch is in the open position). Hold the locking disc $\frac{3}{8}$ inch below the interlock bracket (see Figure 22) and drill $\frac{7}{16}$ -inch holes through the vertical-operating-pipe section, using the holes in the locking-disc collar as pilots. Attach the locking disc to the pipe, using the $\frac{3}{8}$ -16 \times 3 bolt, nut, and lockwasher furnished.
- f. Block one of the two slots in the locking disc with the blocking screw provided. The slot to be blocked will be determined by whether a locked-open or locked-closed arrangement is required.

NOTICE

Key interlocks are intended for proper sequencing of switching operations; they are not intended to provide security. The operating-handle assembly includes swing-away hasps for padlocking the interrupter switch in either the open or closed position.

Complete the operating-handle installation as directed in Steps 10 through 14. Proceed to page 23 for instructions on checking switch operation and adjustment.

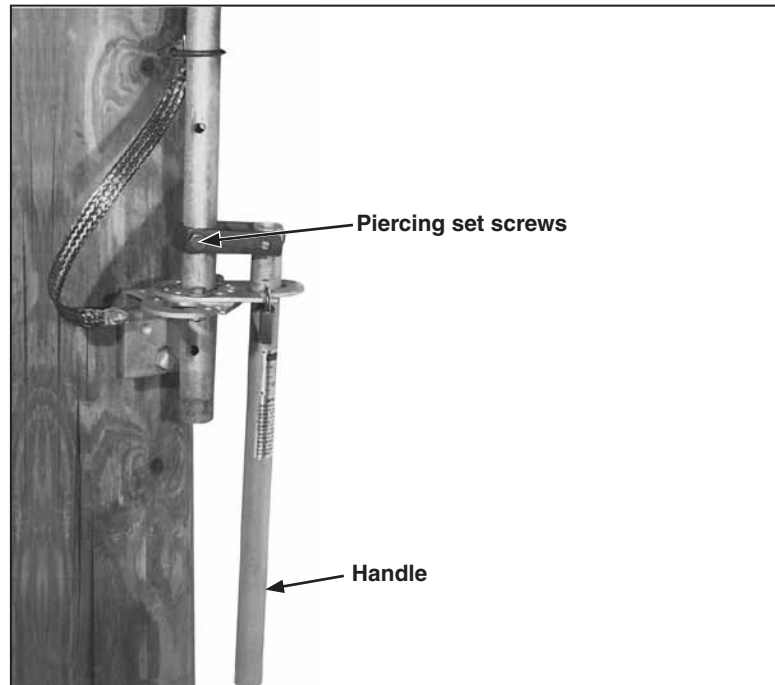

Figure 21. Foot bearing assembly and operating-handle assembly.

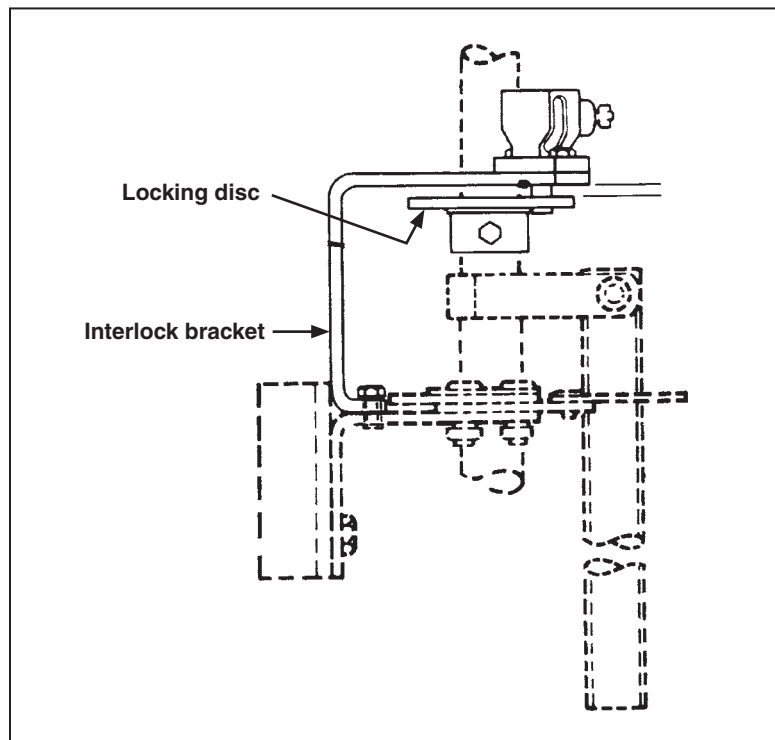

Figure 22. Key-interlock group detail.

Checking Operation

Step 23

Open and close the interrupter switch by swinging the handle slowly through its full travel. Check to be sure that the following conditions exist:

- With the operating handle as far as it will go in the closing direction, all main contacts of the interrupter switch are in the fully-closed position. See Figure 23.
- With the operating handle as far as it will go in the opening direction, the switch blades are 90° from the closed position.

If adjustment is required, loosen the hinge-end bolts that fasten the blade assembly to its insulator and move the switch blade until it is in the fully-closed position with the blade against the bumper stop; then retighten the bolts making sure the blade remains in the fully-closed position. (Cypoxy insulators—torque $\frac{3}{8}$ -16 hardware to 22 ft. lbs.; porcelain insulators—torque $\frac{1}{2}$ -13 hardware to 55 ft. lbs.) See Figure 24.

If adjustment is required *beyond* that provided by moving the switch-blade assembly, loosen the two clamping bolts and set screw that fasten the coupling to the interphase rod and rotate the switch blade until it is in the fully-closed position. Re-tighten the clamping bolts and set screw, making sure the interrupter switch remains in the fully closed position.

Step 24

For 14.4 kV switches. Check the following on each phase.

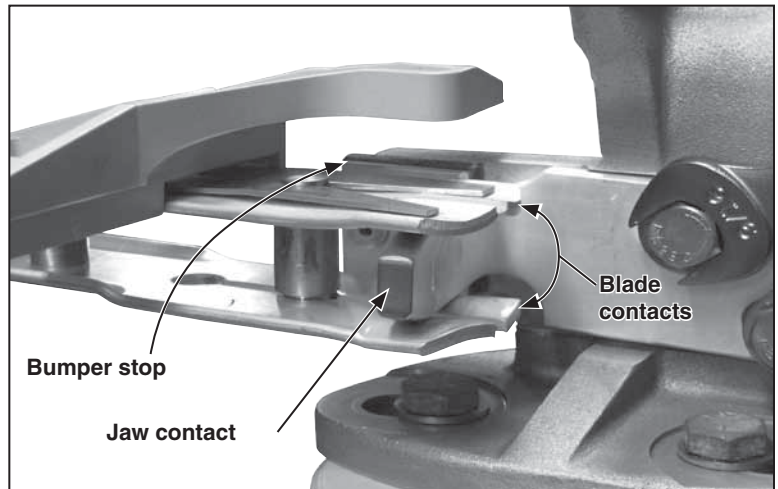

Figure 23. Make sure the jaw contact is fully-centered between the blade contacts and that the blade contacts are against the bumper stop.

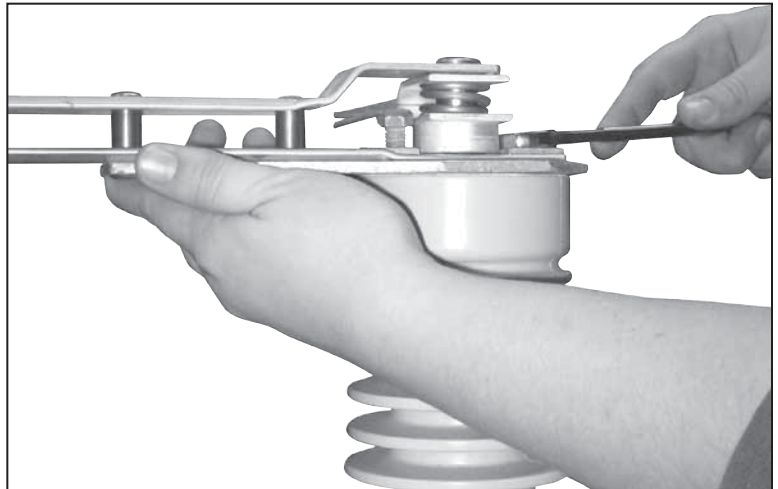

Figure 24. Loosen the blade hardware if necessary and move blade to the fully-closed position against the bumper stop.

Installation

- a. Open and close the switch and examine the interrupter and blade alignment. The interrupter must be parallel to the sweep of the blade.
- b. Partially open the switch. The following conditions should be met:
 - A $\frac{1}{32}$ " minimum clearance between the **top** of the opening cam and the **bottom** of the closing lever, at their closest point.
 - A $\frac{1}{32}$ " minimum clearance between the top of the opening lever and the bottom of the closing cam.
- c. Open the switch and place the blade in the position shown in Figure 25, View A. The following conditions should be met:
 - A $\frac{1}{64}$ " minimum clearance between the opening cam and the opening lever.
 - A clearance between $\frac{3}{32}$ " and $\frac{7}{32}$ " between the shunt contact and the interrupter housing at the beginning of the closing sweep.
- d. Place the switch in the fully-closed position. The following conditions should be met:
 - A clearance of $\frac{1}{16}$ "– $\frac{9}{32}$ " between the closing cam and the closing lever.
 - A $\frac{1}{2}$ " minimum clearance between the blade shunt contact and the interrupter housing contact.

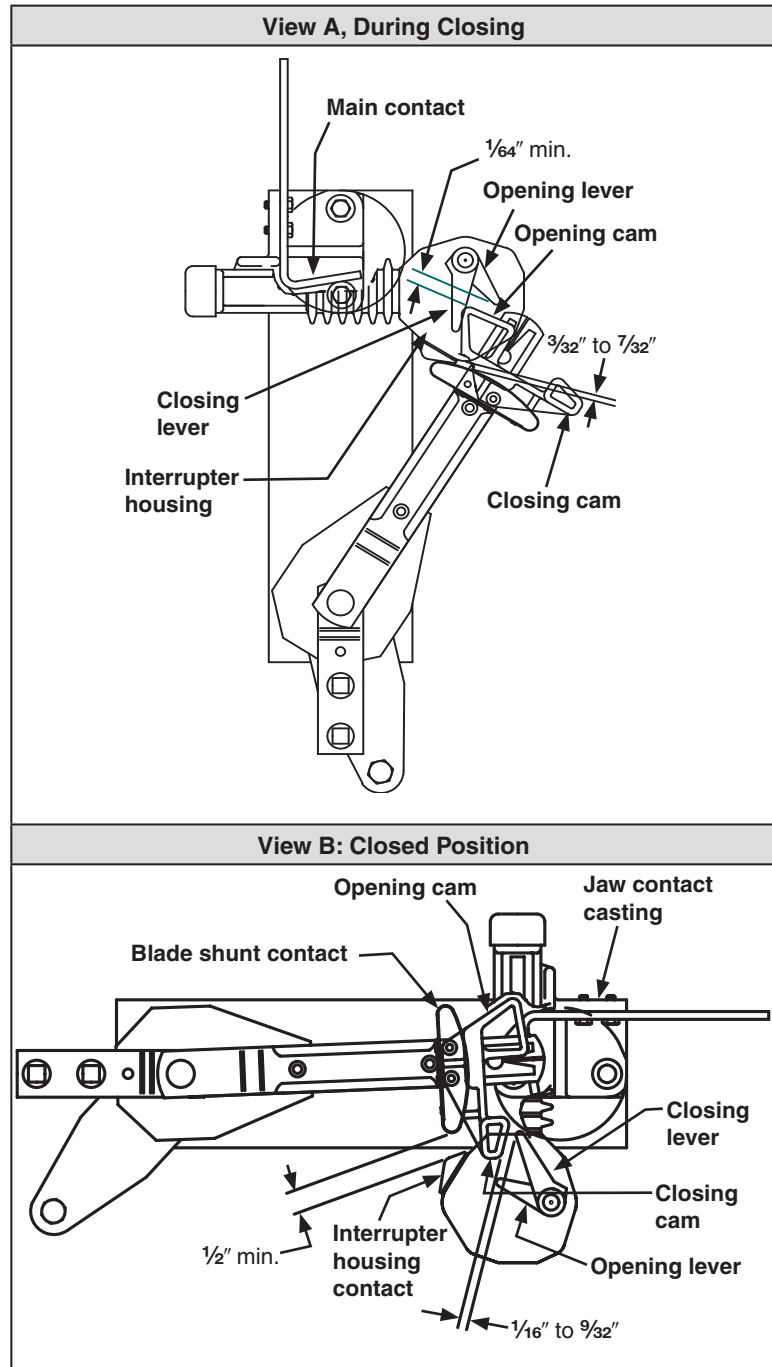

Figure 25. Operating checkpoints for switches rated 14.4 kV.

- e. Slowly open the switch. As the blade moves in the opening direction, the blade shunt contact must firmly engage the interrupter housing contact before the blade disengages from the jaw contact. Bend and reform the shunt contact if necessary to attain the proper contact.
- f. Slowly close the switch. At the start of the closing stroke, the interrupter housing should be at the distance checked in c) above and should continue to make contact with the shunt contact during the duration of the closing stroke. This will ensure that the shunt contact and interrupter housing contact stay in the circuit long enough for the interrupter to break the circuit during the opening stroke.
- g. If adjustment is required, loosen the bolts that fasten the jaw-contact casting to its insulator and slightly rotate the casting in order to achieve the necessary clearances. Retighten the bolts, making sure that the blade engages the stationary contact on-center.

NOTICE

If any of the conditions described above cannot be achieved, it is likely that damage was sustained during shipping or storage. Contact the nearest S&C Sales Office for assistance.

Installation

Step 25

For 25 kV switches. Check the following on each phase.

- a. Examine the interrupter and blade alignment. The interrupter must be parallel to the sweep of the blade.
- b. Partially open the switch. The following conditions should be met:
 - A $\frac{1}{32}$ " clearance between the bottom of the opening cam and the top of the closing lever
 - A $\frac{1}{32}$ " minimum clearance between the bottom of the closing lever and the top of the blade.
- c. Open the switch and place the blade in the position shown in Figure 26, View A. The following conditions should be met:
 - A $\frac{1}{64}$ " minimum clearance between the opening cam and the opening lever.
 - A clearance between $\frac{5}{32}$ " and $\frac{7}{32}$ " between the shunt contact and the interrupter housing at the beginning of the closing sweep.
- d. Place the switch in the fully-closed position. The following conditions should be met:
 - A clearance of $\frac{1}{8}$ " to $\frac{3}{8}$ " between the closing cam and the closing.
 - A $\frac{1}{2}$ " minimum clearance between the blade shunt contact and the interrupter housing contact

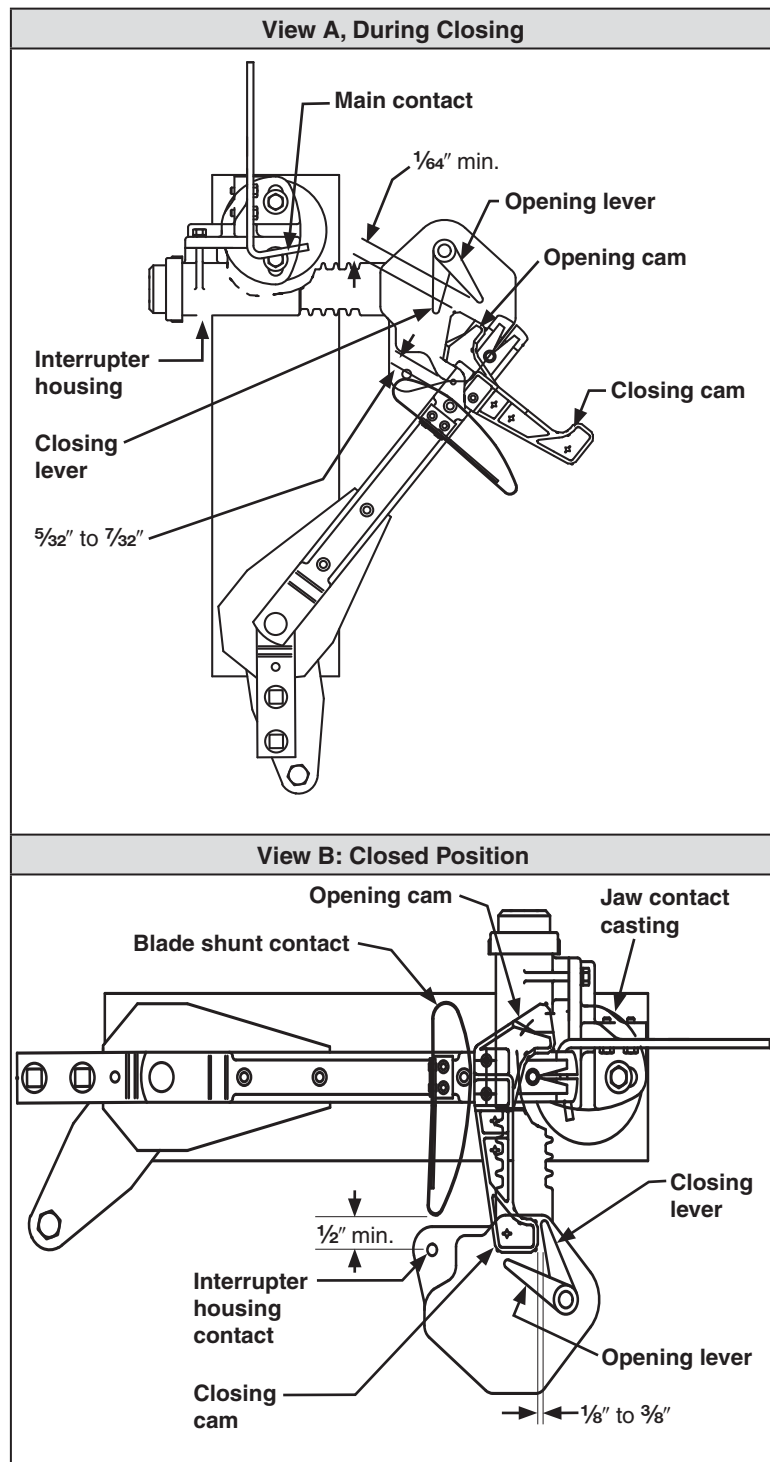

Figure 26. Operating checkpoints for switches rated 25 kV.

- e. Slowly open the switch. As the blade moves in the opening direction, the blade shunt contact must firmly engage the interrupter housing contact before the blade disengages from the jaw contact. Bend and reform the shunt contact if necessary to attain the proper contact.
- f. Slowly close the switch. At the start of the closing stroke, the interrupter housing should be at the distance checked in Step 24 c) and should continue to make contact with the shunt contact during the duration of the closing stroke. This will ensure that the shunt contact and interrupter housing contact stay in the circuit long enough for the interrupter to break the circuit during the opening stroke.
- g. If adjustment is required, loosen the bolts that fasten the jaw-contact casting to its insulator and slightly rotate the casting in order to achieve the necessary clearances. Retighten the bolts, making sure that the blade engages the stationary contact on-center.

If any of the conditions described above cannot be achieved, it is likely that damage was sustained during shipping. Contact the nearest S&C Sales Office for assistance.

NOTICE

If any of the conditions described above cannot be achieved, it is likely that damage was sustained during shipping or storage. Contact the nearest S&C Sales Office for assistance.

