

Installation and Operation

Table of Contents

Section	Page	Section	Page
Introduction		Installation	
Qualified Persons	2	Mounting to a Wood Pole	9
Read this Instruction Sheet.	2	Uncrating the Switch.	9
Retain this Instruction Sheet.	2	Lifting the Upright Mounting Configuration Switch	10
Proper Application.	2	Installing Pipe Couplings with Piercing Set Screws . . .	12
Operating Considerations.	3	Installing the Vertical Operating Pipe	13
Warranty	3	Installing the Operating Handle	16
Warranty Qualifications.	3	Installing the Operating Handle with Key Interlock. . . .	17
Safety Information		Checking Alignment and Adjusting the Stop Plates . . .	19
Understanding Safety-Alert Messages	4	Checking Operation	22
Following Safety Instructions	4	Connecting High-Voltage Conductors.	24
Replacement Instructions and Labels.	4	Operation	
Location of Safety Labels and Tags	5	Opening and Closing the Switch.	25
Safety Precautions	6		
Shipping and Handling			
Inspection	7		
Packing	7		
Handling	8		



Introduction

Qualified Persons

⚠ WARNING

The equipment covered by this publication must be installed, operated, and maintained by qualified persons who are knowledgeable in the installation, operation, and maintenance of overhead electric power distribution equipment along with the associated hazards.

A qualified person is one who is trained and competent in:

- The skills and techniques necessary to distinguish exposed live parts from nonlive parts of electrical equipment
- The skills and techniques necessary to determine the proper approach distances corresponding to the voltages to which the qualified person will be exposed
- The proper use of the special precautionary techniques, personal protective equipment, insulating and shielding materials, and insulated tools for working on or near exposed energized parts of electrical equipment

These instructions are intended only for such qualified persons. They are not intended to be a substitute for adequate training and experience in safety procedures for this type of equipment.

Read this Instruction Sheet

NOTICE

Thoroughly and carefully read this instruction sheet before installing or operating your S&C Alduti-Rupter Switch. Familiarize yourself with Safety Information and Safety Precautions on pages 4 through 6. The latest version of this publication is available online in PDF format at sandc.com/Support/Product-Literature.asp.

Retain this Instruction Sheet Proper Application

This instruction is a permanent part of your S&C Alduti-Rupter Switch. Designate a location where you can easily retrieve and refer to this publication.

⚠ WARNING

The equipment in this publication must be selected for a specific application. The application must be within the ratings furnished for the equipment. Refer to S&C Specification Bulletin 761-31 for complete application information.

In most applications, Alduti-Rupter Switches are capable of switching rated continuous load currents at full voltage. The ratings for the particular switch are listed on nameplates attached to the operating handle and the switch. See Figure 1.

These interrupter switches are not intended for breaking fault currents.

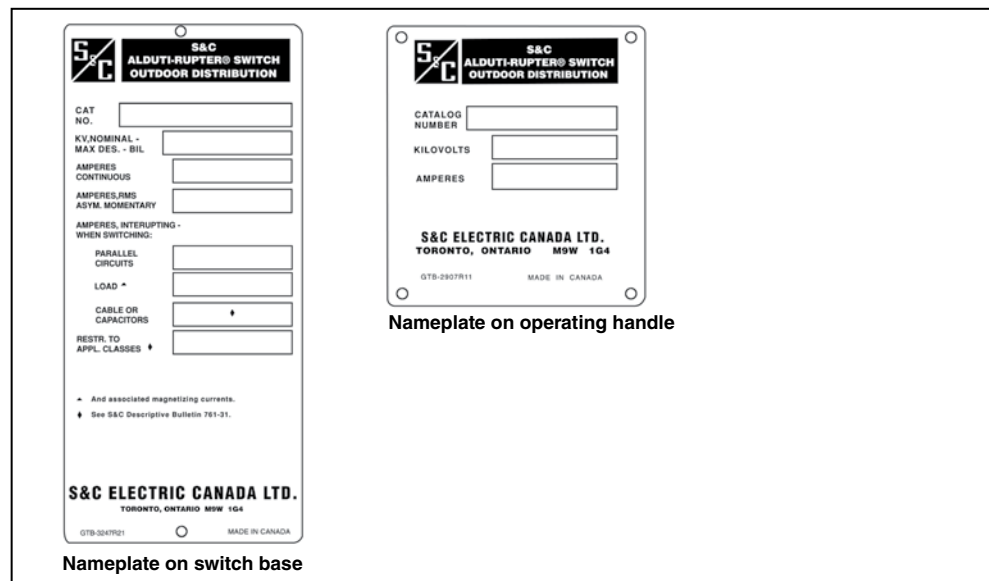

Figure 1. Switch nameplates with ratings.

Operating Considerations

Circuit making and breaking is involved in the normal operation of these interrupter switches, and partial or precautionary opening or closing of the switch should not be attempted. If the switch is covered in ice or snow, do not “chop” the switch between the **Open** and **Closed** position to dislodge the ice.

To operate the switch, swing the handle through its full stroke without hesitation. Do not assume that the operating handle position indicates the Open or Closed position of the interrupter switch blades. After opening or closing the switch, always make a visual check of the blade position to determine that the switch blades are in the intended position. Tag or padlock the operating handle in accordance with standard system operating practices. In all cases, make sure the operating handle is locked before “walking away” from the switch.

Alduti-Rupter Switches are not intended for breaking fault currents.

Warranty

The warranty and/or obligations described in Price Sheet 150, S&C’s “Standard Conditions of Sale—Immediate Purchasers in the United States” (or Price Sheet 153, Standard Conditions of Sale—Immediate Purchasers Outside the United States) plus any special warranty provisions, as set forth in the applicable product-line specification bulletin, are exclusive. The remedies provided in the former for breach of these warranties shall constitute the immediate purchaser’s or end user’s exclusive remedy and a fulfillment of the entire seller’s liability. In no event shall the seller’s liability to the immediate purchaser or end user exceed the price of the specific product that gives rise to the immediate purchaser’s or end user’s claim. All other warranties, whether express or implied or arising by operation of law, course of dealing, usage of trade or otherwise, are excluded. The only warranties are those stated in Price Sheet 150, (or Price Sheet 153) and THERE ARE NO EXPRESS OR IMPLIED WARRANTIES OF MERCHANTABILITY OR FITNESS FOR A PARTICULAR PURPOSE. ANY EXPRESS WARRANTY OR OTHER OBLIGATION PROVIDED IN PRICE SHEET 150 (OR PRICE SHEET 153) IS GRANTED ONLY TO THE IMMEDIATE PURCHASER AND END USER, AS DEFINED THEREIN. OTHER THAN AN END USER, NO REMOTE PURCHASER MAY RELY ON ANY AFFIRMATION OF FACT OR PROMISE THAT RELATES TO THE GOODS DESCRIBED HEREIN, ANY DESCRIPTION THAT RELATES TO THE GOODS, OR ANY REMEDIAL PROMISE INCLUDED IN PRICE SHEET 150 (or PRICE SHEET 153.)

Warranty Qualifications

The standard warranty is applicable to the S&C Alduti-Rupter Switch detailed in this instruction sheet except when it is power operated using a switch operator of other than S&C manufacture.

Safety Information

Understanding Safety-Alert Messages

Several types of safety-alert messages may appear throughout this instruction sheet and on labels and tags attached to the Alduti-Rupter Switch. Familiarize yourself with these types of messages and the importance of these various signal words:

DANGER

“DANGER” identifies the most serious and immediate hazards that *will likely* result in serious personal injury or death if instructions, including recommended precautions, are not followed.

WARNING

“WARNING” identifies hazards or unsafe practices that *can* result in serious personal injury or death if instructions, including recommended precautions, are not followed.

CAUTION

“CAUTION” identifies hazards or unsafe practices that *can* result in minor personal injury if instructions, including recommended precautions, are not followed.

NOTICE

“NOTICE” identifies important procedures or requirements that *can* result in product or property damage if instructions are not followed.

Following Safety Instructions

If you do not understand any portion of this instruction sheet and need assistance, contact your nearest S&C Sales Office or S&C Authorized Distributor. Their telephone numbers are listed on S&C’s website sandc.com, or call S&C Headquarters at (773) 338-1000; in Canada, call S&C Electric Canada Ltd. at (416) 249-9171.

NOTICE

Read this instruction sheet thoroughly and carefully before installing or operating your S&C Alduti-Rupter Switch.



Replacement Instructions and Labels

If you need additional copies of this instruction sheet, contact your nearest S&C Sales Office, S&C Authorized Distributor, S&C Headquarters, or S&C Electric Canada Ltd.

It is important that any missing, damaged, or faded labels on the equipment be replaced immediately. Replacement labels are available by contacting your nearest S&C Sales Office, S&C Authorized Distributor, S&C Headquarters, or S&C Electric Canada Ltd.

Location of Safety Labels and Tags

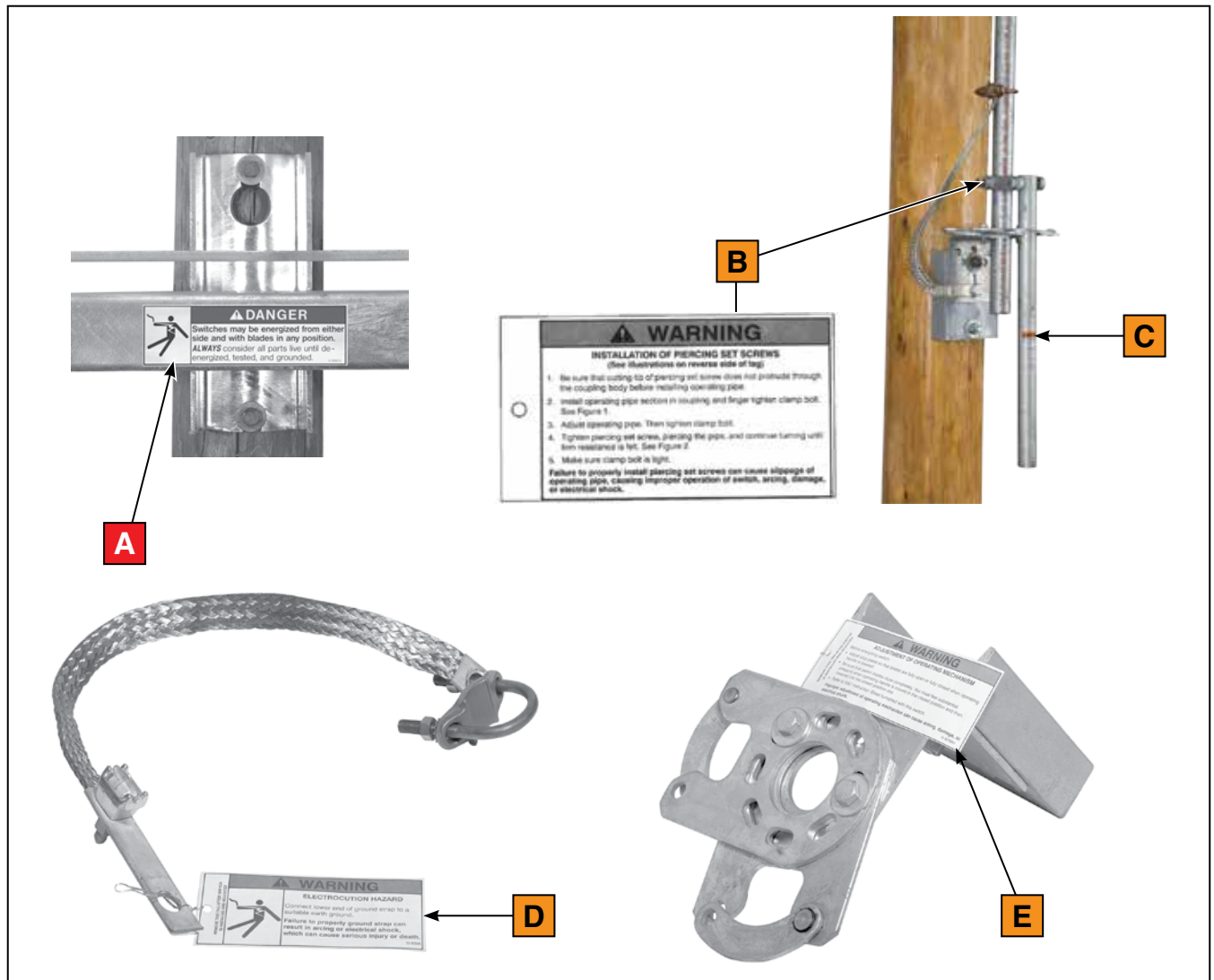

Reorder Information for Safety Labels

Location	Safety Alert Message	Description	Number
A	⚠ DANGER	Electrocution Hazard	G-6580-2
B	⚠ WARNING	Piercing Set Screws	G-10200▲
C	⚠ WARNING	Handle Operation	G-4400R5
D	⚠ WARNING	Electrocution Hazard—Grounding Strap	G-6596▲
E	⚠ WARNING	Adjustment of Operating Mechanism	G-3578R1▲

▲ This part is a tag that is to be removed and discarded after the switch is installed and adjusted.

DANGER



Alduti-Rupter Switches operate at high voltage. Failure to observe the precautions below will result in serious personal injury or death.

Some of these precautions may differ from your company's operating procedures and rules. Where a discrepancy exists, follow your company's operating procedures and rules.

- 1. QUALIFIED PERSONS.** Access to switches and controls must be restricted only to qualified persons. See "Qualified Persons" on page 2.
- 2. SAFETY PROCEDURES.** Always follow safe operating procedures and rules.
- 3. PERSONAL PROTECTIVE EQUIPMENT.** Always use suitable protective equipment such as rubber gloves, rubber mats, hard hats, safety glasses, and flash clothing, in accordance with safe operating procedures and rules.
- 4. SAFETY LABELS AND TAGS.** Do not remove or obscure any of the "DANGER," "WARNING," "CAUTION," or "NOTICE" labels.
- 5. ENERGIZED COMPONENTS.** Always consider all parts live until de-energized, tested, and grounded.
- 6. INTERRUPTER SWITCH POSITION.** Always confirm the **Open/Close** position of interrupter switches by visually observing the position of the blades. Switches may be energized from either side and with the blades in any position.
- 7. MAINTAINING PROPER CLEARANCE.** Always maintain proper clearance from energized components.
- 8. OPERATION.** Circuit making and breaking is involved in the normal operation of this interrupter switch and, as a result, "partway" opening or closing is undesirable. To operate, swing the operating handle through its full travel vigorously and without hesitation. See "Operation" on page 25.

Inspection

Examine the shipment for external evidence of damage as soon after receipt as possible, preferably before removal from the carrier's conveyance. Check the bill of lading to make sure that shipping skids, crates, and containers listed thereon are present:

If there is visible loss and/or damage:

1. Notify the delivering carrier immediately.
2. Ask for a carrier inspection.
3. Note condition of shipment on all copies of the delivery receipt.
4. File a claim with the carrier.

If concealed damage is discovered:

1. Notify the delivering carrier within 15 days of receipt of shipment.
2. Ask for a carrier inspection.
3. File a claim with the carrier.

Notify S&C Electric Company in all instances of loss and/or damage.

Packing

Standard Mounting Arrangements

When a standard mounting arrangement is specified, the shipment includes:

- A three-pole interrupter switch, complete with interphase drive, factory assembled on a single base (All switch adjustments, including that of the interphase drive, are made at the factory to ensure proper operation and simultaneity of opening and closing.)
- Three vertical operating-pipe sections ①②
- Operating-mechanism components, such as handle, guide bearings, and couplings—each tagged and keyed to the bill of material for ready identification

Besides this instruction sheet, a detailed erection drawing is included, illustrating the applicable mounting arrangement.

The erection drawing shows minimum or suggested locating dimensions for the vertical operating-pipe guide bearings and the operating handle assembly. The actual locations of these components are to be determined either by qualified persons at the site or by the user's engineering department.

Standard Minor Modifications

The erection drawing also indicates the standard minor modifications available for the standard mounting arrangement. The components included with these modifications are shown on the erection drawing bill of material under the specified "-S" suffix. They include:

- -S1: One tubular fiberglass insulating section in vertical operating shaft
- -S2: One Cypoxy™ Insulator unit in vertical operating shaft
- -S6: Key interlock—single lock for "locked-open" application
- -S8: Provision for power operation of pole-mounted switches by S&C Switch Operator—Type AS-1A
- -S16: Provision for power operation of pole-mounted switches by S&C 6801M Automatic Switch Operator

Drawing RD-10005, detailing the various modifications, is included in addition to the erection drawing.

① Not furnished with switches ordered "less operating pipe."

② If desired, the pipe can be cut to length (if not precut at the factory) before proceeding to the job site. Cutting dimensions are shown on the erection drawing.

Power Operation

If suffix “-S8” is specified, S&C Instruction Sheet 769-500, “S&C Switch Operators—Type AS-1A,” is included with the switch operator shipment. Instruction Sheet 769-500 covers installation, operation, and adjustment of the switch operator and should be used in conjunction with this instruction sheet where applicable. If suffix “-S16” is specified, associated S&C instruction sheets for the 6801M Automatic Switch Operator are included with the switch operator shipment.

Handling

The crate the switch is packed in is designed to be moved and lifted using a lift truck. Raised slots in the bottom of the crate are provided for a lift truck’s forks.

NOTICE

To minimize time-consuming final adjustments after installation, make sure the switch poles are in their fully **Closed** position and their toggle mechanisms are against their closed stops during installation of the vertical operating-pipe sections. Switch blades can be tied to their jaw-contact members, and the toggle mechanisms can be tied to their stops.

WARNING

DO NOT lift the switch by rigging on the “live parts” or subject these parts to undue stress from slings or fall lines.

Lifting the switch by the live parts will damage the switch. Rough handling may cause damage to the blades, contacts, and/or interrupters.

Failure to lift the switch properly can result in switch damage, causing improper operation, arcing, or electrical shock.

Mounting to a Wood Pole

STEP 1. Drill two $\frac{1}{16}$ -inch diameter holes through the utility pole as shown at the desired height for mounting the switch. See Figure 2. Refer to the erection drawing.

STEP 2. Insert a $\frac{5}{8}$ -inch diameter through-bolt (not furnished) into each hole. See Figure 3.

Loosely attach a square washer, Belleville washer (when mounting to a wood utility pole), and nut on each bolt. See Figure 4.

NOTICE

When mounting to a wood utility pole, a Belleville-type washer must be used between the square washer and the nut to maintain fastener tightness in the event of wood shrinkage. See Figure 4.

Uncrating the Switch

STEP 3. Remove the switch from its crate. See Figure 5. Protect the bearings from contamination by dirt, mud, oil, etc. If necessary, use blocks to keep the bearings clear of the ground.

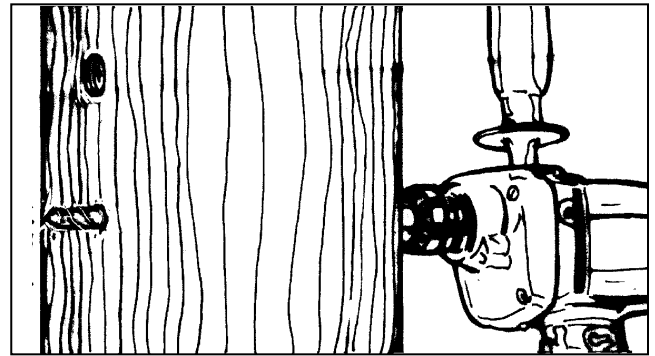

Figure 2. Drill the holes for the switch-mounting bracket.

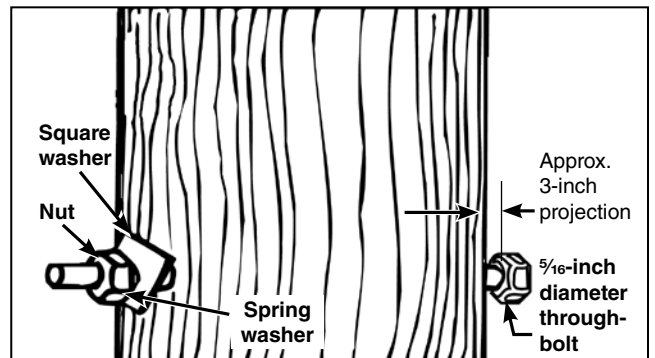

Figure 3. Install the through-bolts.

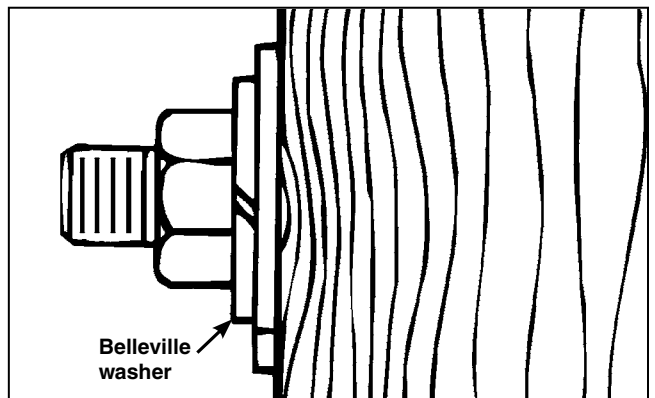

Figure 4. Install a Belleville washer.

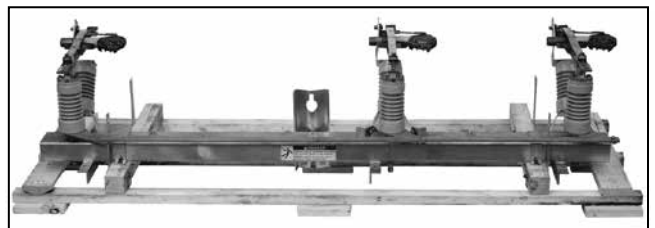

Figure 5. Uncrating the switch.

Installation

Lifting the Upright Mounting Configuration Switch

STEP 4. To minimize time-consuming final adjustments, make sure the switch is fully closed. Tie the switch blades to their stationary main contact assemblies. See Figure 6.

STEP 5.

⚠ CAUTION

DO NOT lift the switch poles by rigging to the live parts. Avoid allowing the switch poles to swing while lifting.

Lifting the switch by the live parts will damage the switch. Rough handling may cause damage to the blades and contacts.

Failure to lift the switch properly can result in switch damage, causing improper operation, arcing, or electrical shock.

Hoist the switch using the four lifting devices. Each lifting device consists of a lifting strap attached to a 4×4-inch wood support member banded to the switch base. See Figure 7.

STEP 6. Guide the switch so the through-bolt heads enter into the keyhole slot and open slotted hole in the switch base. See Figure 8.

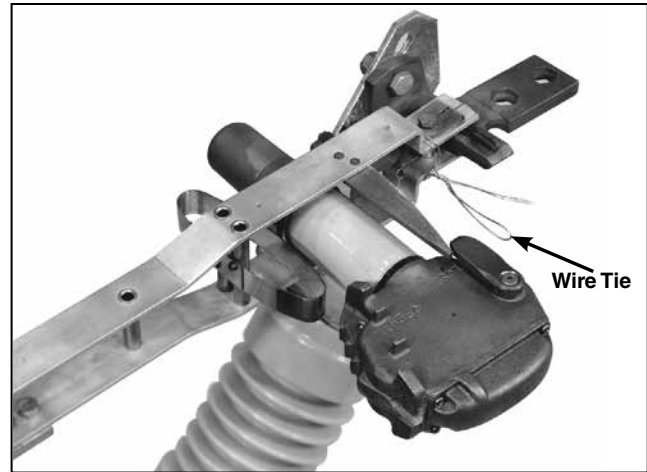

Figure 6. Tie the switch blade to the main contacts.

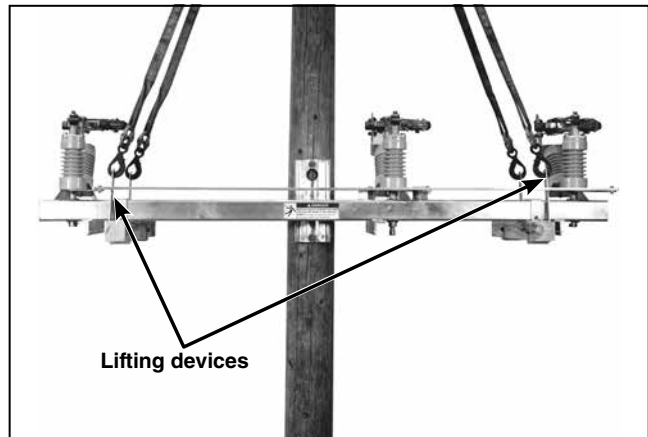

Figure 7. Hoisting the switch into position.

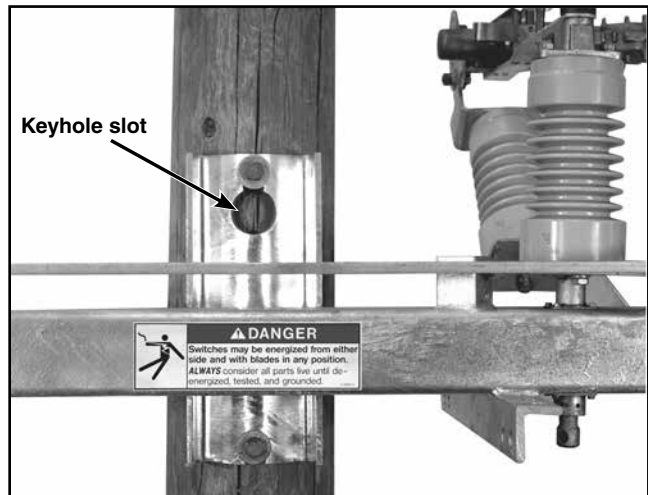

Figure 8. Guiding the switch.

- STEP 7.** Slowly lower the switch until it just bears on the through-bolts. Fully tighten the bolts. See Figure 9. Afterward, remove the lifting slings.
- STEP 8.** Attach the pole band to the switch base anchor brackets using the J-bolts furnished. Use a stiffening block under each nut. See Figure 10.
Use a 5/8-inch diameter lag bolt (not furnished) to secure the pole band to the utility pole.
- STEP 9.** Remove the wood support members, lifting straps, and banding straps provided to facilitate hoisting of the switch. See Figure 11.

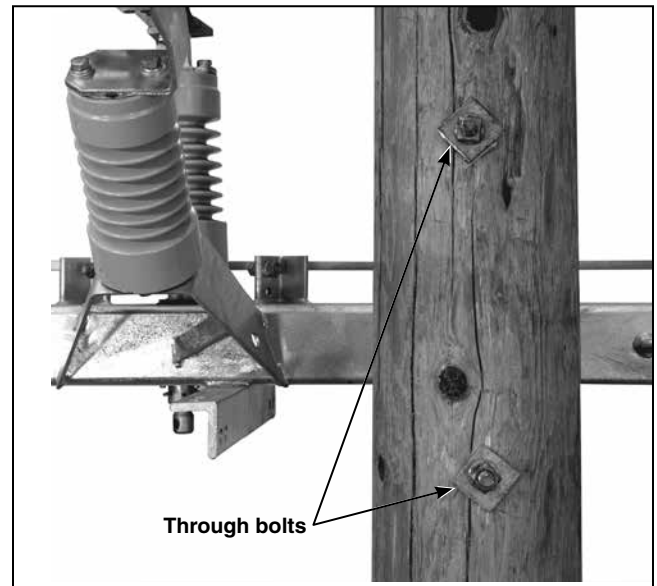

Figure 9. Bolt the switch to the wood pole.

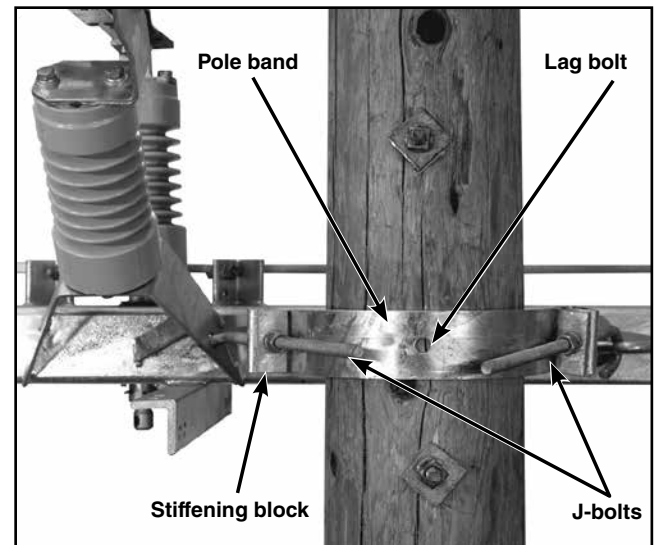

Figure 10. Attach the pole band and J-bolts.

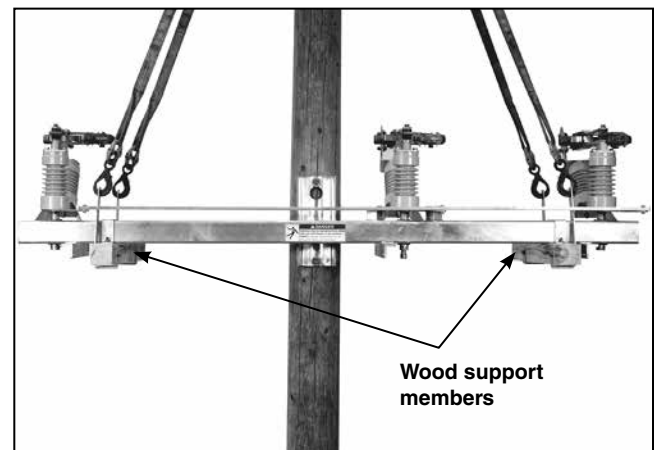

Figure 11. Remove the wood support members.

Installation

STEP 10. If desired, crossarm braces (user furnished) may be attached to the switch base. See Figure 12. Refer to the erection drawing.

NOTICE

In the case of insulated-base models, the mounting brackets for crossarm braces must be specified separately.

Installing Pipe Couplings with Piercing Set Screws

STEP 11.

WARNING

Failure to properly install pipe couplings with piercing set screws can cause the operating pipe to slip, resulting in improper operation of the switch, arcing, equipment damage, or electrical shock.

To properly install piercing set screws:

- Back the piercing set screw out of the coupling so the tip does not protrude into the body of the coupling.
- Insert the operating pipe section into the coupling, and finger-tighten the clamp bolt(s).
- Adjust the operating pipe to the correct length. Tighten the clamp bolt(s) to final tightness.
- Tighten the piercing set screw, piercing the pipe. Continue turning until a firm resistance is felt.
- Make sure the clamp bolt(s) are tight.
See Figure 13.

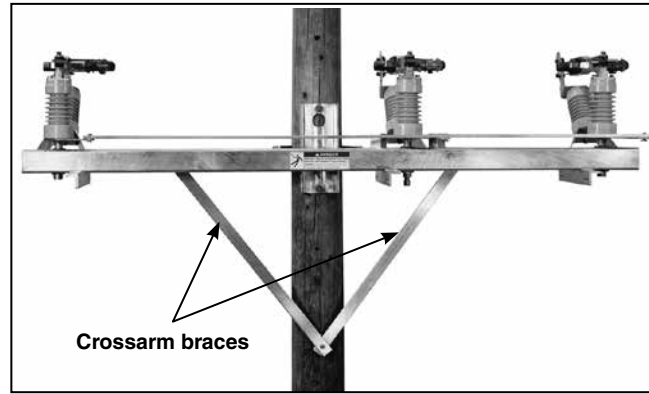

Figure 12. Attaching the crossarm braces (user-furnished) to the switch base.

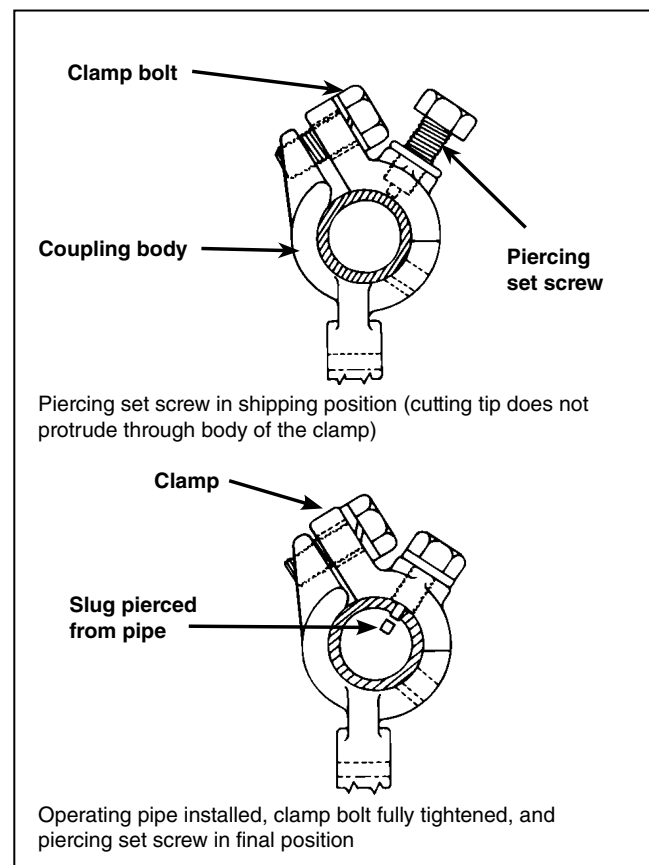

Figure 13. Install the pipe couplings.

Installing the Vertical Operating Pipe

STEP 12. Attach a pipe-to-switch bearing type universal coupling to the switch drive shaft on the underside of the switch assembly. See Figure 14.

STEP 13. Insert the uppermost section of the vertical operating pipe into the universal coupling attached to the underside of the switch assembly. See Figure 15. Make certain the cutting tip of the piercing set screw does not protrude through the body of the pipe-coupling clamp.

Torque the clamp bolts to final tightness, and then tighten the piercing set screw, piercing the pipe. Continue turning until a firm resistance is felt.

STEP 14. Attach a pipe-to-pipe type universal coupling to the lower end of the uppermost section of vertical operating pipe. See Figure 16. Back the piercing set screw out of the body of the pipe coupling before tightening the coupling clamp bolts.

Torque the clamp bolts to final tightness, and then tighten the piercing set screw, piercing the pipe. Continue turning until a firm resistance is felt.

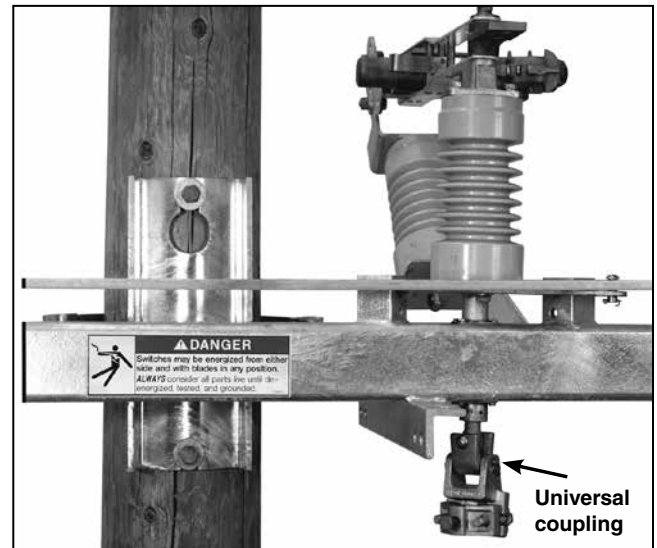

Figure 14. Attaching the universal coupling to switch the drive shaft.

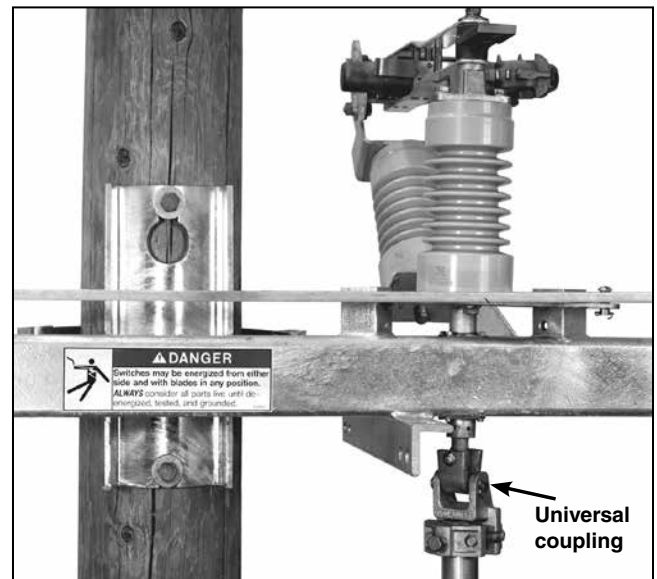

Figure 15. Install the uppermost section of the vertical operating pipe.

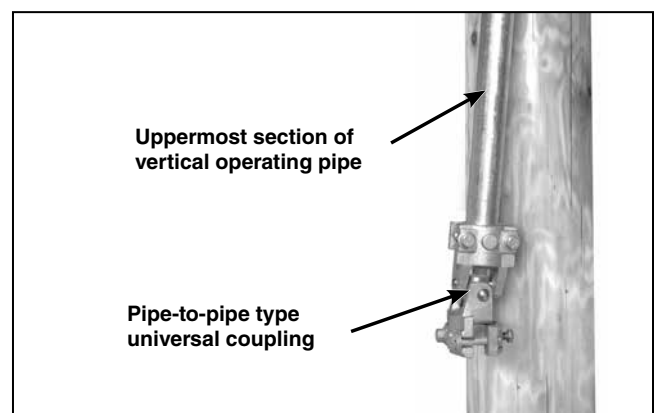

Figure 16. Attach the pipe-to-pipe type universal coupling to the lower end of the vertical operating pipe.

Installation

STEP 15. Position and install the guide bearing assembly on the pole in accordance with the dimension shown on the erection drawing. See Figure 17.

STEP 16. Pass the next section of vertical operating pipe up through the guide bearing and then through the thrust bearing. The thrust bearing will rest on the guide bearing and support the operating pipe. See Figure 18.

Insert the pipe section into the universal coupling previously attached to the lower end of the uppermost operating-pipe section. *Do not tighten the coupling clamp at this time.*

While holding the pipe in this position—and with the thrust bearing resting on the guide bearing—tighten the piercing set screw in the thrust bearing, piercing the pipe. Continue turning until a firm resistance is felt.

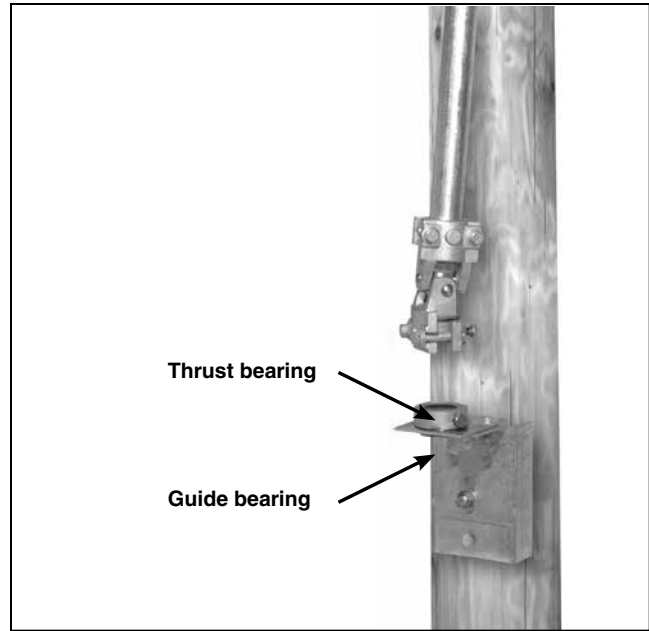

Figure 17. Install the guide bearing.

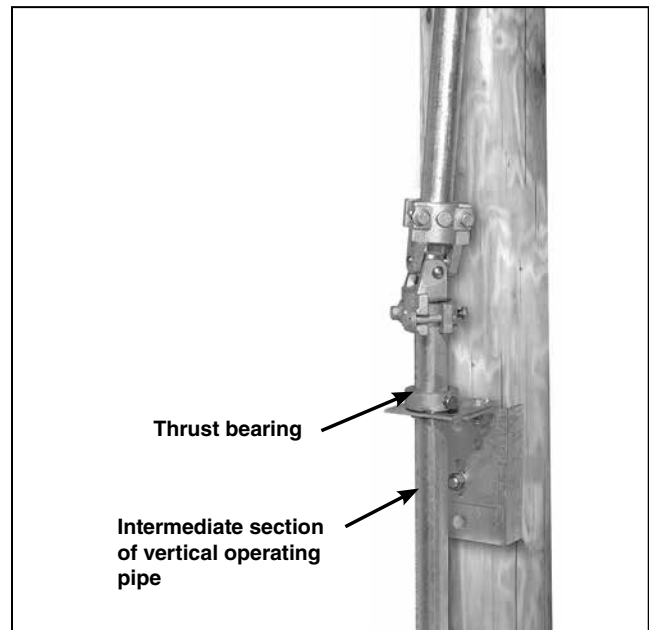

Figure 18. Install the intermediate section of the vertical operating pipe.

STEP 17. Install a guide bearing assembly with each additional vertical operating-pipe section, positioned in accordance with the dimension shown on the erection drawing. See Figure 19. Thrust bearings are only necessary on the uppermost guide bearing. Use rigid couplings to join these additional pipe sections. Before installing the coupling, back the piercing set screws out of the coupling body so they do not protrude into the coupling.

Torque the clamp bolts to final tightness, and then tighten the piercing set screws, piercing the pipe. Continue turning until a firm resistance is felt.

STEP 18. At the universal coupling immediately above the thrust bearing, torque the clamp bolts to final tightness. Tighten the piercing set screw, piercing the pipe. Continue turning until a firm resistance is felt.①

① If the shipment includes an S&C Type AS-1A Switch Operator, as signified by the addition of the standard minor modification suffix “-S8” to the erection drawing number, refer instead to S&C Instruction 769-500, “S&C Switch Operators—Type AS-1A, Instructions for Installation.”

If the shipment includes an S&C 6801M Automatic Switch Operator, as signified by the addition of standard minor modification suffix “-S16” to the erection drawing number, refer instead to S&C Instruction Sheet 1045M-510.

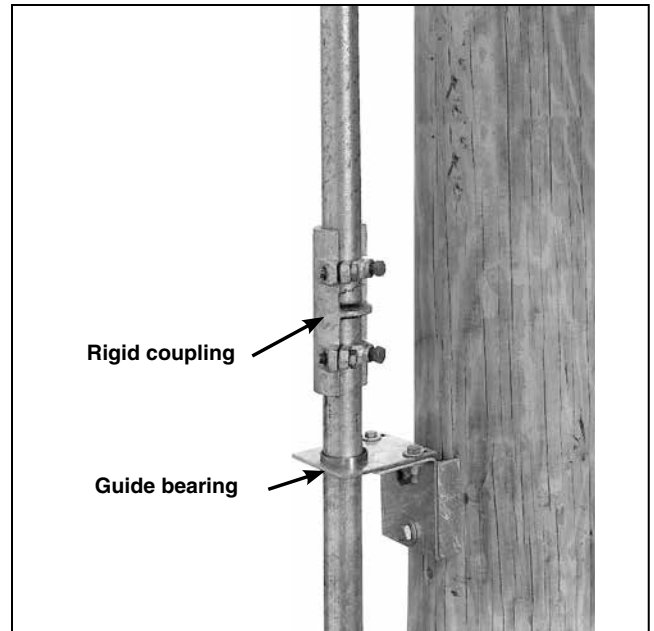

Figure 19. Installing the intermediate section of the vertical operating pipe.

Installation

Installing the Operating Handle

When a key interlock is used (standard minor modification suffix “-S6”), skip to Step 22 on page 17.

When a Type AS-1A Switch Operator is used (standard minor modification suffix “-S8”), refer instead to S&C Instruction Sheet 769-510 for installation instructions.

When an S&C 6801M Automatic Switch Operator is used (standard minor modification suffix “-S16”), refer instead to S&C Instruction Sheet 1045M-510 for installation instructions.

STEP 19. Back the piercing set screws out of the handle yoke and slide the handle assembly up the pipe until it is in the location indicated on the erection drawing. There should be 3 to 8 inches of operating pipe below the operating handle assembly. See Figures 20 and 21. Tighten the piercing set screws on the operating handle assembly enough to hold the handle in place. DO NOT pierce the vertical operating pipe.

STEP 20. Slide the foot-bearing assembly onto the lowest section of pipe at the position shown on the erection drawing. See Figure 21. Adjust the operating handle assembly until it is two to three inches above the foot-bearing assembly. Tighten the piercing set screws, piercing the pipe. Continue turning until a firm resistance is felt.

At the same time, use one of the mounting bolts to attach one end of the ground strap (the end with the grounding connector attached) to the foot-bearing assembly. The grounding recommendations may differ from the standard operating and safety procedures of certain electric utility companies. Where a discrepancy exists, the operating procedures of the electric utility apply.

If necessary to compensate for the taper of the wood pole and to keep the vertical operating pipe aligned and plumb, shift the guide bearings toward or away from the pole. Alignment slots are provided for this purpose.

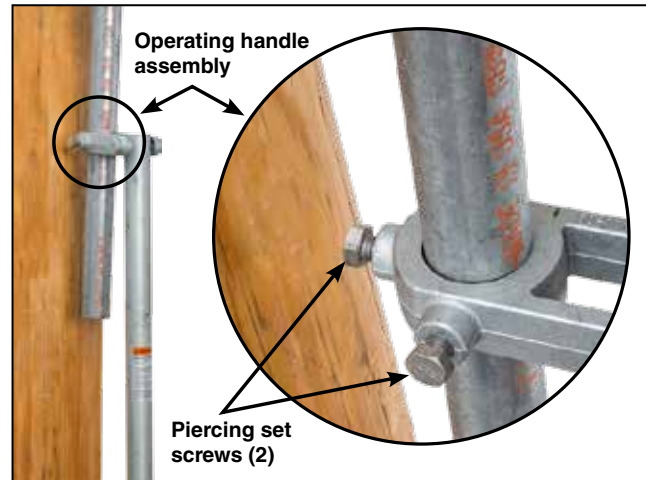

Figure 20. Fasten the operating handle assembly.

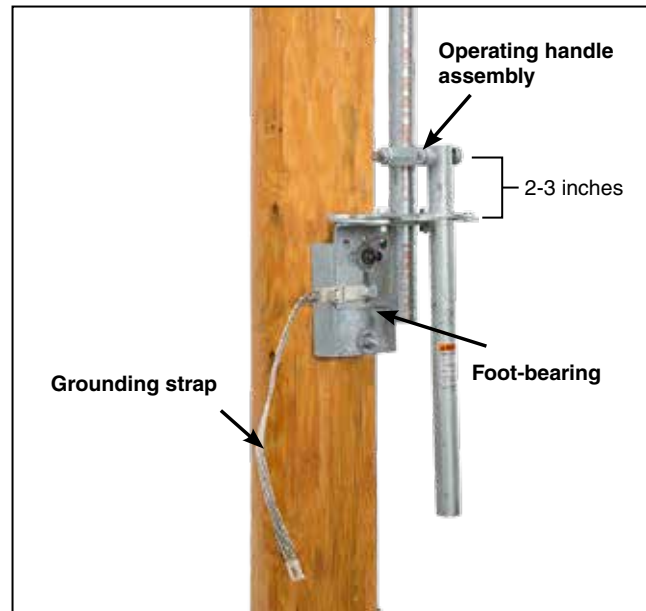

Figure 21. Install the foot-bearing assembly so the handle is two to three inches above the foot-bearing assembly.

STEP 21. Fasten the free end of the grounding strap to the lowest pipe section a few inches above the operating handle assembly (or key interlock) with the U-bolt connector provided for this purpose. See Figure 22. Connect the lower end of the strap to a suitable earth ground using the grounding connector provide at that end of the strap. The grounding recommendations in this procedure may differ from the standard operating and safety procedures of certain electric utility companies. Where a discrepancy exists, the operating procedures of the electric utility apply.

Installing the Operating Handle with Key Interlock

NOTICE

The key interlock must be installed *after* the operating handle is installed and the stop plates are fully adjusted.

STEP 22. The interlock group includes a Superior Type B6003-1 Mk II single- or multiple-key interlock (or equivalent) with a $\frac{3}{8}$ -inch bolt projection and a $\frac{3}{4}$ -inch bolt travel, locking disc, and interlock bracket. If “provision only” is specified, the interlock is not included.

Slide the interlock bracket, locking disc, operating handle assembly, and foot-bearing assembly onto the lowest vertical operating-pipe section, with the locking disc and operating handle assembly between the interlock bracket and the foot-bearing assembly. See Figure 23.

STEP 23. Bolt the foot-bearing assembly to the pole at the position shown on the erection drawing. Use one of the mounting bolts to attach one end of the grounding strap (the end with the grounding connector attached) to the foot-bearing assembly. The grounding recommendations may differ from the standard operating and safety procedures of certain electric utility companies. Where a discrepancy exists, the operating procedures of the electric utility apply. See Figure 24.

If necessary to compensate for the taper of the wood pole and to keep the vertical operating pipe aligned and plumb, shift the guide bearing toward or away from the pole. Alignment slots are provided for this purpose.

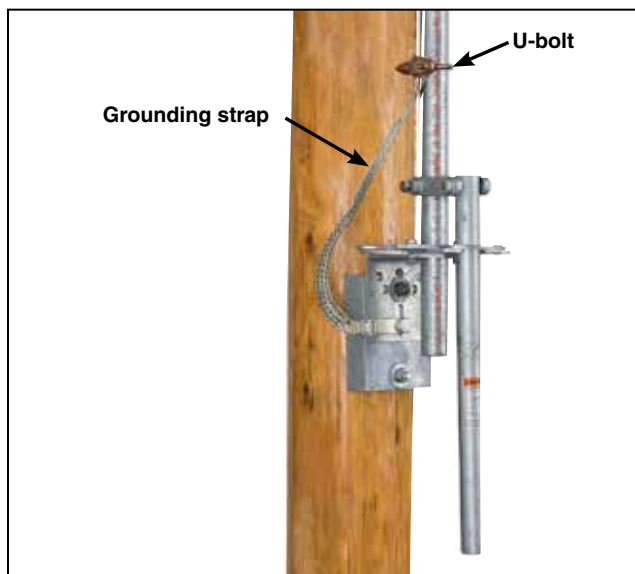

Figure 22. Install the grounding strap.



Figure 23. Position the interlock bracket, locking disc, operating handle assembly, and foot-bearing assembly onto the lowest vertical operating-pipe section

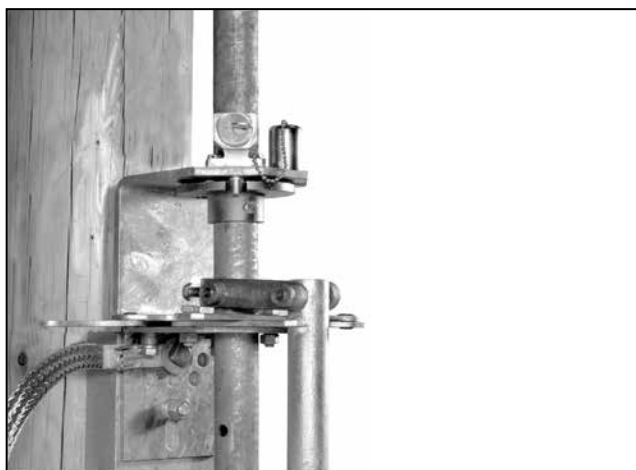

Figure 24. Attach the foot-bearing.

Installation

STEP 24. Fasten the operating handle assembly to the lowest vertical operating-pipe section using the piercing set screws furnished.

Tighten the piercing set screws on the operating handle assembly, piercing the pipe. Continue turning until a firm resistance is felt.

Attach the interlock bracket to the foot-bearing assembly, using the $\frac{1}{2}$ -13 \times 1 $\frac{1}{2}$ -inch cap screws, spacers, and lockwashers furnished.

With the switch in the **Closed** position, use the interlock bolt to position the locking disc so the bolt enters the closed-position slot in the disc (and will enter the open-position slot when the switch is in the **Open** position). See Figure 25.

STEP 25. Hold the locking disc $\frac{3}{8}$ -inch below the interlock bracket and drill $\frac{7}{16}$ -inch diameter holes through the vertical operating-pipe section using the holes in the locking disc collar as pilots. Attach the locking disc to the pipe using the $\frac{3}{8}$ -16 \times 3-inch cap screw, lockwasher, and nut furnished. See Figure 26.

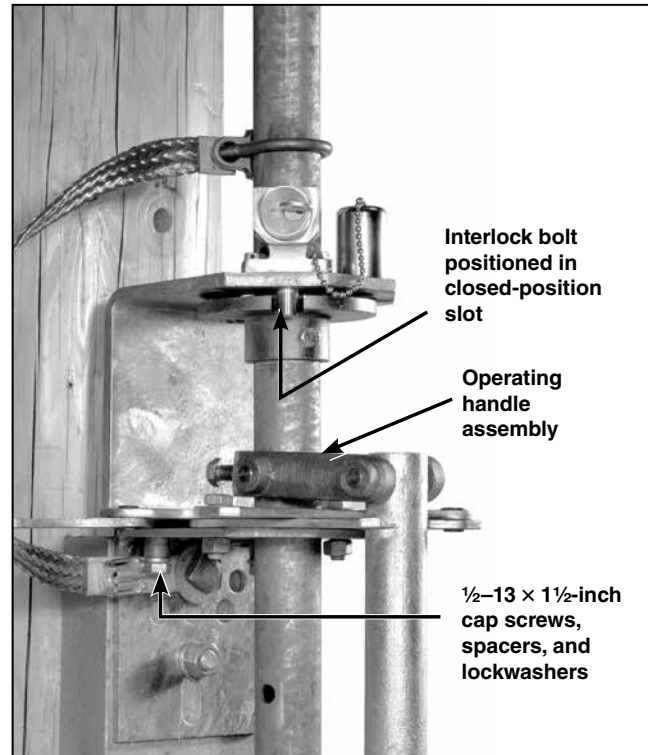

Figure 25. Fasten the operating handle assembly.

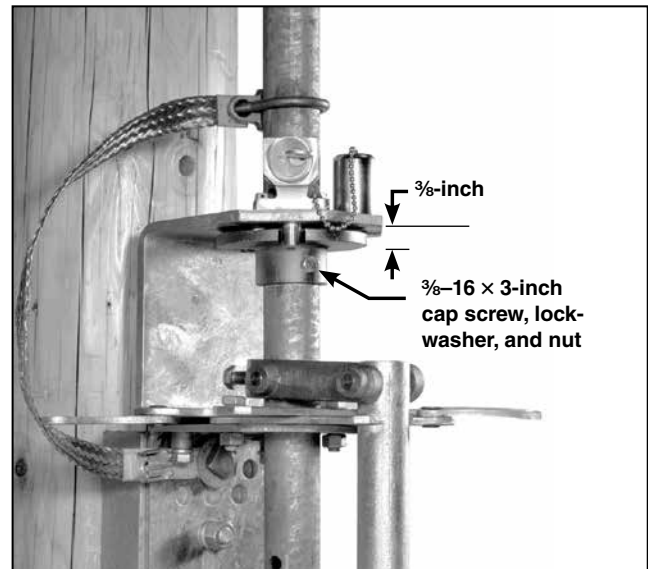

Figure 26. Attach the locking disc.

STEP 26.**NOTICE**

Key interlocks are intended for proper sequencing of switch operations; they are not intended to provide security. The operating handle assembly includes swingaway hasps for padlocking the switch in either the **Open** or **Closed** position.

Block one of the two slots in the locking disc with the blocking screw provided. (The slot to be blocked depends on whether a locked-open or locked-closed arrangement is required.) See Figure 27.

Checking Alignment and Adjusting the Stop Plates**NOTICE**

The switch should be opened and closed slowly only when checking for alignment and complete closure.

When opening or closing the switch in service, *do not* slow down or stop part way. Arcing will occur if the switch is partially open or partially closed.

STEP 27. Remove the ties holding the switch blades to their stationary main contact assemblies. See Figure 28.

Open and close the switch *slowly* to ensure no operational difficulties are encountered caused by undetected damage in shipping.

STEP 28. The stop plate holes are slotted to allow room for adjustment. Loosen the bolts that secure the adjustable stop plates to the foot-bearing support plate. See Figure 29 on page 20. Place the switch in the fully **Open** position and adjust the open-position stop plate so the handle, when lowered, fits into the open-position slot. Mark the location of the open-position stop plate on the support plate.

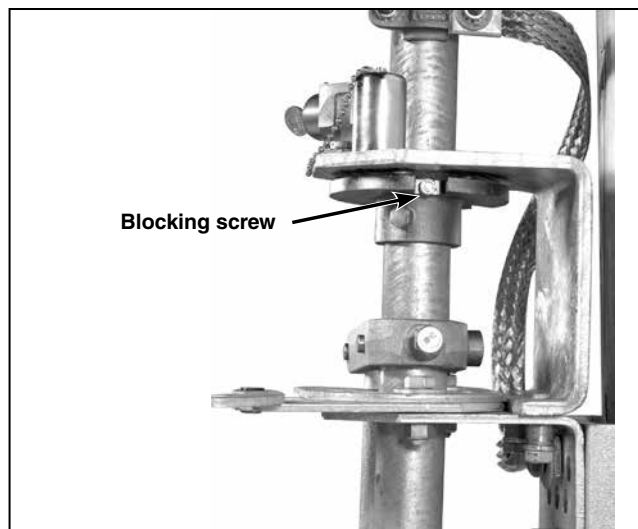

Figure 27. Blocking slot in interlock disc.

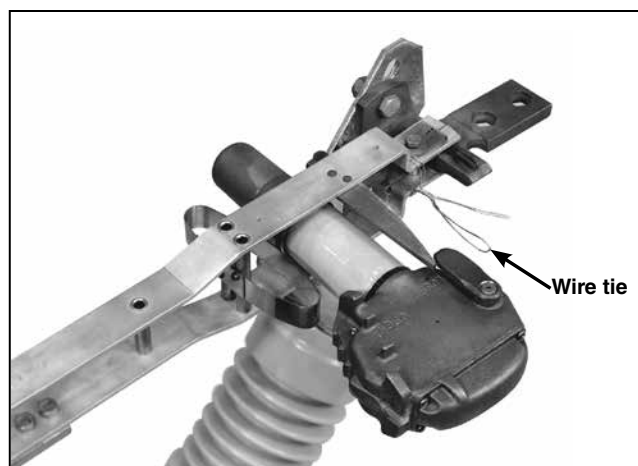

Figure 28. Removing the tie at the stationary main contact assembly.

Installation

STEP 29.

NOTICE

DO NOT skip this important step! Loose or improperly installed vertical operating pipe is the primary cause of incomplete blade and jaw contact. Over time this condition can cause heating and eventually arcing of the blade contacts.

The most common cause of contact overheating and damage is not putting enough “wind up” torque in the vertical operating pipe when the switch is in the **Closed** position. Wind up is the torque left in the pipe after the handle is secured in the closed stop plate. This windup prevents the pipe from vibrating in high winds and creates strong positive blade-to-contact pressure—ensuring the switch is securely held in the **Closed** position.

To adjust the closed stop plate:

- (a) Loosen the hardware securing the closed stop plate. See Figure 29.
- (b) The stop plate holes are slotted to allow room for adjustment. Position the operating handle in the stop plate and turn the operating handle as far as it will go in the **Closed** position. (Counterclockwise is standard on switches using the rotating operating mechanism.) The handle should be tight against the edge of the stop plate. See Figure 30. Mark the position of the closed stop plate. See Figure 31 (left) on page 21.
- (c) Lift the handle out of the way and rotate the closed stop plate an additional 15 degrees counterclockwise from the mark. See Figure 31 (right) on page 21. Make sure the open stop plate lines up with the mark made previously in Step 28 on page 19. Tighten the stop plate hardware to 40 ft-lbs.

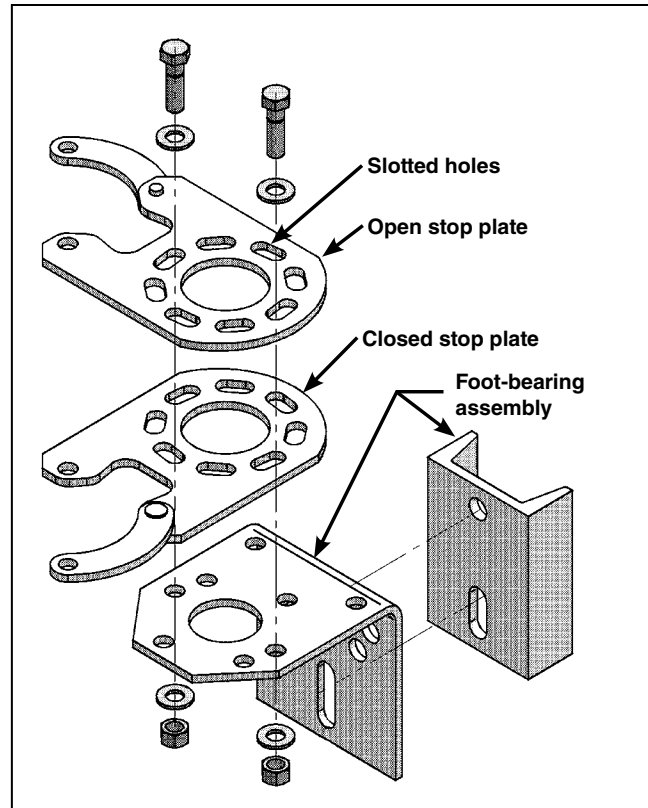

Figure 29. Exploded view of stop plates and foot-bearing assembly.

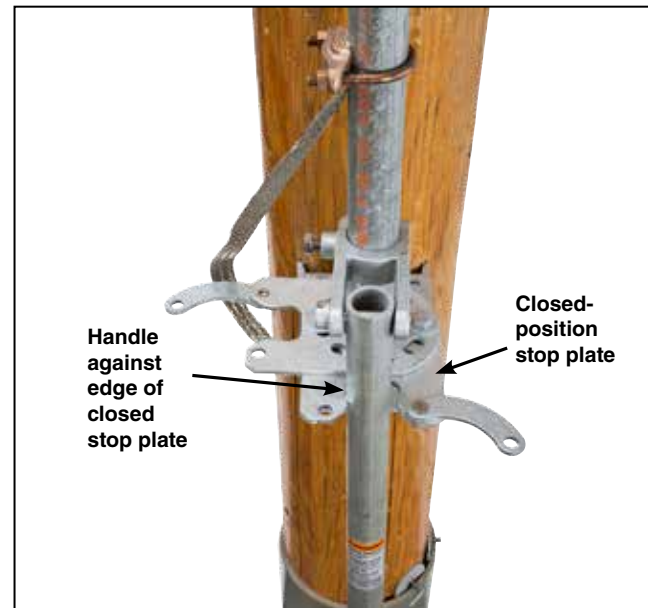

Figure 30. Adjust the closed-position stop plate.

- (d) Push the handle into the closed stop position. It should take significant force to secure the handle into the closed stop. The handle will be firmly pressed against the left side of the closed stop plate. This pressure will hold the torque in the pipe, creating the desired windup. Move the handle into the **Open** position to verify it fits into the open stop plate. See Figure 32.

STEP 30. Recheck to be sure all clamp bolts and piercing set screws have been torqued to final tightness.

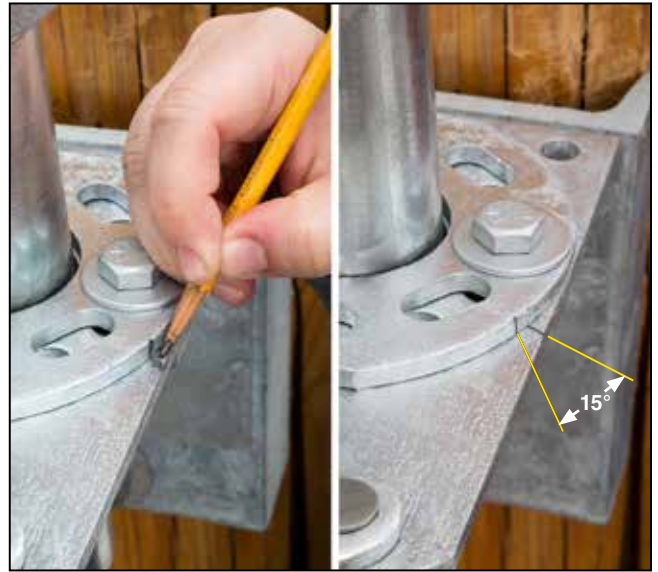

Figure 31. Torque the bolts securing stop plates to support plate.



Figure 32. Verify the wind-up.

Installation

Checking Operation

STEP 31.

NOTICE

Open and close the switch slowly **ONLY** when checking the operation or making adjustments to the de-energized switch.

When opening or closing an energized switch, swing the operating handle vigorously through its full travel without hesitation.

Arcing and damage to the switch will occur if the energized switch is operated slowly or left in the partially Open or Closed position.

Open and close the switch slowly through its full travel.

Check to be sure the following conditions exist:

- (a) With the operating handle as far as it will go in the *closing* direction, all main contacts of the interrupter switch are in the fully **Closed** position. See Figure 33.
- (b) With the operating handle as far as it will go in the *opening* direction, the switch blades are 90 degrees from the **Closed** position. See Figure 34.
- (c) If adjustment is required, loosen the hinge-end bolts that fasten the blade assembly to its insulator and move the switch blade until it is in the fully **Closed** position. Retighten the bolts, making sure the interrupter switch remains in the fully **Closed** position.

STEP 32.

NOTICE

Open and close the switch slowly **ONLY** when checking the operation or making adjustments to the de-energized switch. When opening or closing an energized switch, swing the operating handle vigorously through its full travel without hesitation. Arcing and damage to the switch will occur if the energized switch is operated slowly or left in the partially **Open** or **Closed** position.

Check the operation of each switch pole. The following conditions must be met:

- (a) The interrupter must lie in a plane parallel to the sweep of the blades, and the blades must pass over the interrupter with approximately equal clearance on both sides. See Figure 35.

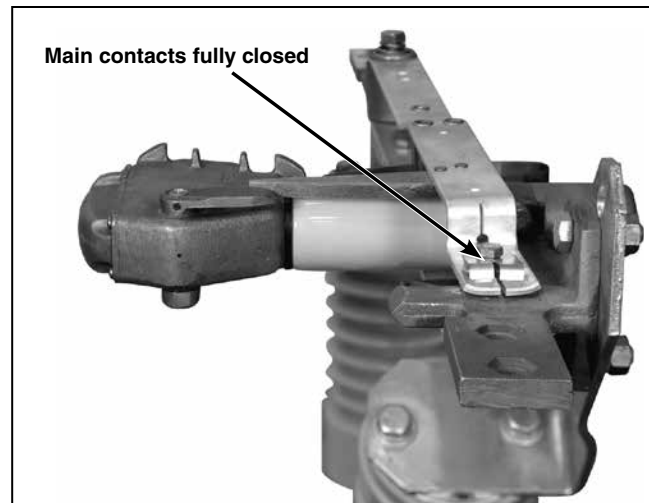

Figure 33. Check that the blade is fully closed.

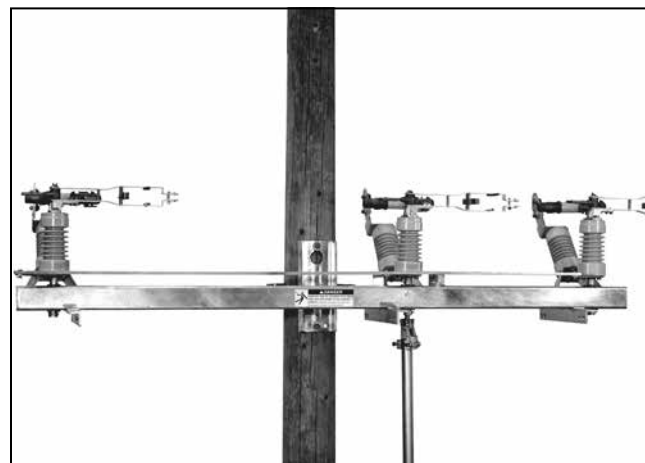

Figure 34. Checking that switch blades are 90 degrees from the Closed position.

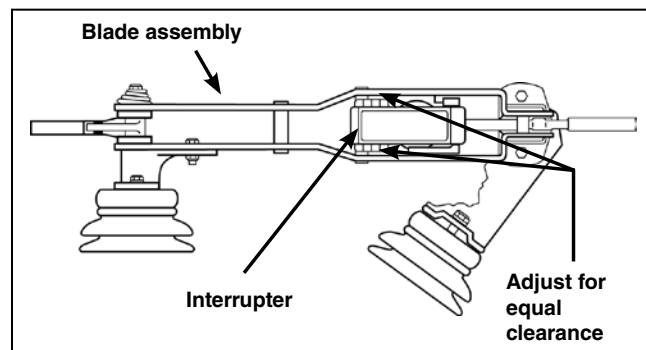

Figure 35. Interrupters lie in a plane parallel to the blade assemblies.

- (b) As the blades move in the *closing* direction, clearance between the blade-opening cams and the interrupter-opening levers must be within the limit shown. See Figure 36.
- (c) In the fully **Closed** position, clearance between the blade-closing cams and the interrupter-closing levers must be within the limit shown. See Figure 37.
- (d) Also, the clearance between the blade-shunt contact and the interrupter housing must be as shown.
- (e) Move the blades in the *opening* direction and verify that each blade-shunt contact firmly engages its respective interrupter housing before the blade contacts disengage from the stationary main contact assemblies. See Figure 38. The shunt contacts may be bent as required to conform to these conditions.

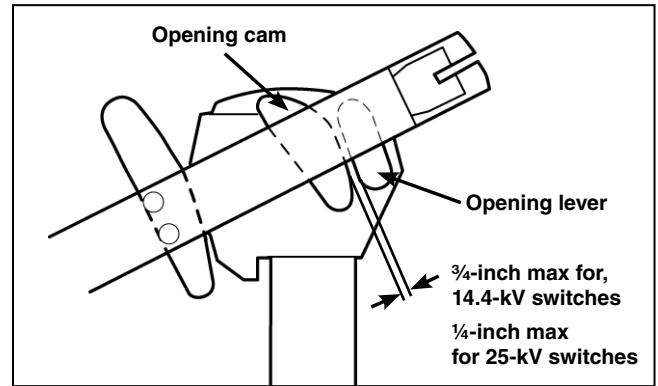

Figure 36. Blade assembly moving in the *closing* direction.

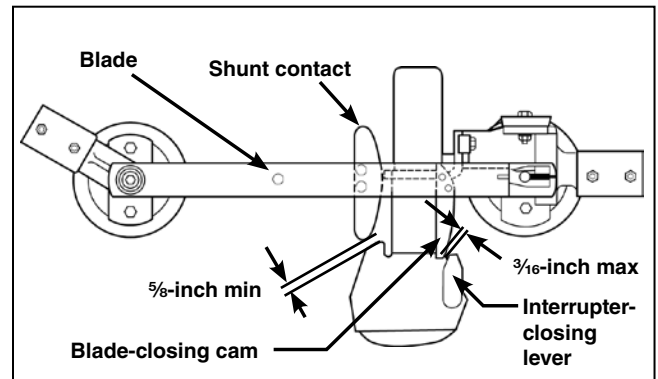

Figure 37. Blade assembly moving in the *opening* direction.

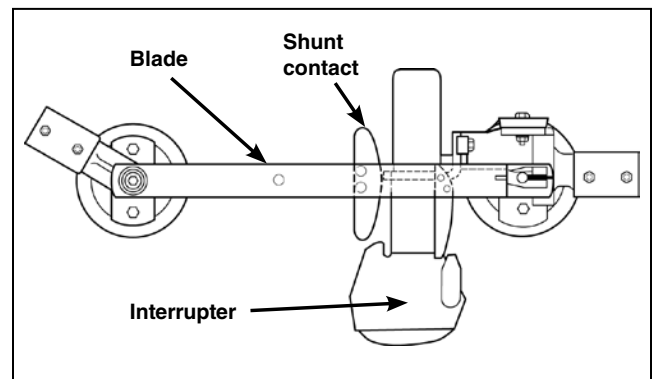

Figure 38. Blade assembly moving in the *opening* direction.

Installation

- (f) If adjustment is required, loosen the bolts that fasten the interrupter to the stationary main contact casting, and reposition the interrupter. See Figure 39.
- (g) It may be necessary to loosen the bolts that fasten the stationary main contact casting to its mounting bracket and slightly rotate the casting to achieve the necessary clearances. See Figure 40. Retighten the bolts, making sure the blade engages the stationary contact on-center.
- (h) If any of the conditions described in this step cannot be achieved, contact the nearest S&C Sales Office because damage likely occurred during shipment.

Connecting High-Voltage Conductors

When high-voltage conductors are to be connected using aluminum-alloy body connectors^①, use the following procedures:

- (a) Thoroughly wire-brush the current-transfer surfaces of each connector and immediately apply a liberal coating of Penetrox® A (available from Burndy Corporation) to the brushed surfaces.
- (b) Wire-brush each terminal pad of the switch and apply a coating of Penetrox A, and then bolt the connectors to the terminal pads.
- (c) Prepare the conductors using established procedures and clamp them in their respective connectors.

^① These are “mass-anode” type connectors, such as the Catalog Number 5300 series offered by S&C, that have been designated by the connector manufacturer as being suitable for direct attachment to copper-bearing alloy terminals pads.

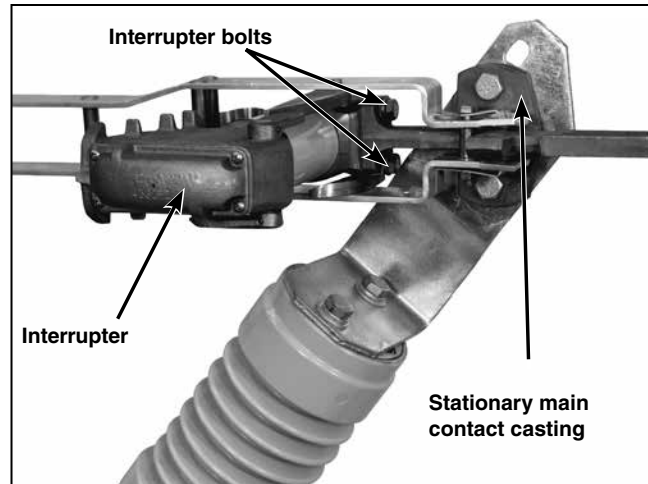

Figure 39. Adjusting the interrupter position.

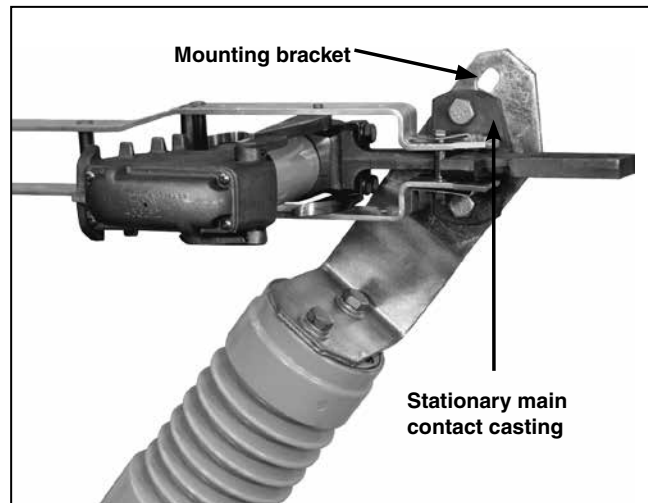

Figure 40. Adjusting the stationary main contact casting position.

Opening and Closing the Switch

⚠ DANGER

The interrupters and terminal pads of the Alduti-Rupter Switch may be energized with the interrupters in any position. Before inspecting, servicing, or repairing this switch or working on the conductors on either side of the switch, test for voltage using proper high-voltage test equipment. Install suitable grounding equipment.

Failure to observe these precautions may result in serious injury or death.

NOTICE

This interrupter switch is not intended for breaking fault currents.

STEP 33. Remove the padlock(s) from the hasps on the operating-handle assembly. See Figure 41.

STEP 34. If the operating handle assembly is furnished with a key interlock, disengage the interlock bolt. See Figure 42.

⚠ CAUTION

Swing the operating handle vigorously through its full travel without hesitation. Arcing and damage to the switch will occur if the energized switch is operated slowly or left in the partially **Open** or **Closed** position.

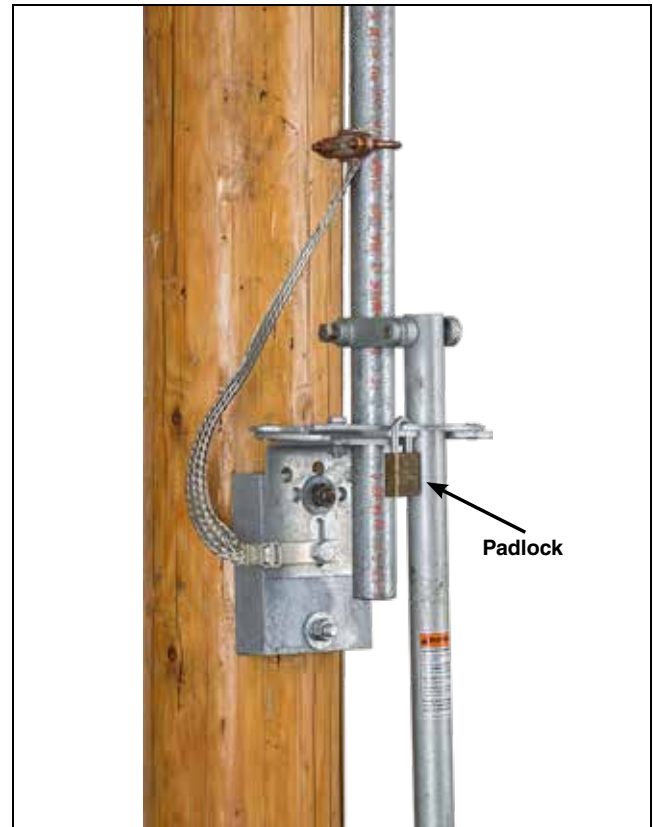

Figure 41. Remove the padlock(s).

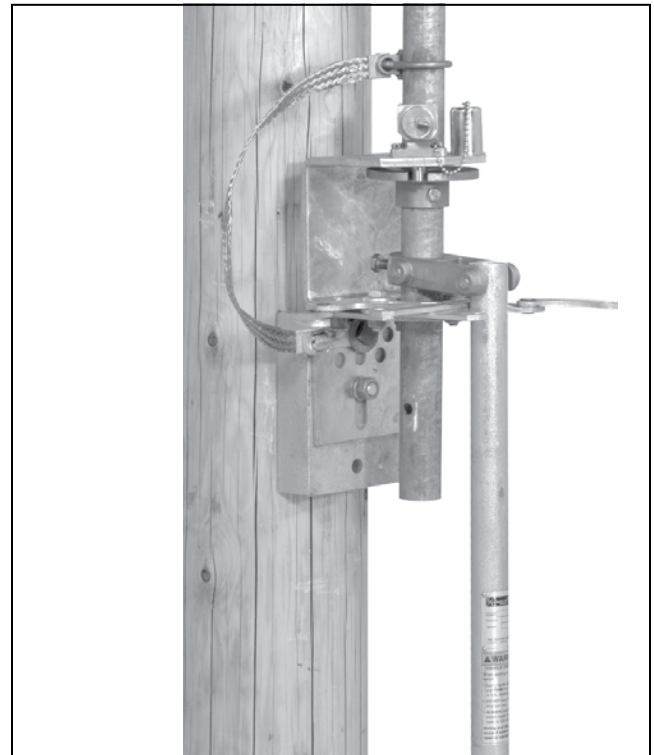

Figure 42. Disengaging the key interlock bolt.

Operation

STEP 35. Swing the handle *rapidly* to the fully **Open** or fully **Closed** position. See Figure 43.

Always check that all three poles are fully open or fully closed.

Replace the padlock(s). Engage the key interlock, if applicable.

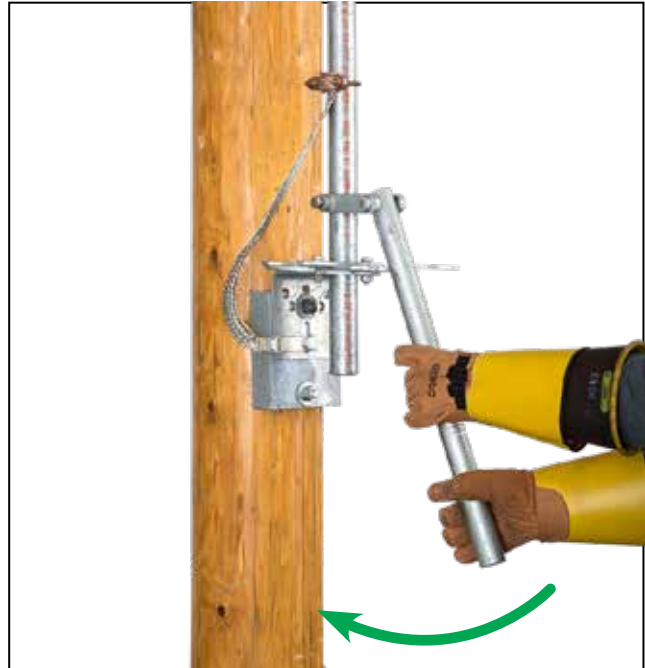

Figure 43. Swinging the operating handle.