

# Installation and Operation

## Table of Contents

<b>Section</b>	<b>Page</b>	<b>Section</b>	<b>Page</b>
<b>Introduction</b>		<b>Installation</b>	
Qualified Persons . . . . .	2	Mounting to Wood . . . . .	9
Read this Instruction Sheet . . . . .	2	Preparing the Pole . . . . .	9
Retain this Instruction Sheet. . . . .	2	Uncrating the Switch. . . . .	10
Proper Application . . . . .	3	Lifting Tiered-Outboard Mounting Configuration Switch . . . . .	10
Warranty . . . . .	4	Lifting Vertical Mounting Configuration Switch. . . . .	12
Warranty Qualifications . . . . .	4	Installing Pipe Couplings with Piercing Set Screws . . . . .	14
<b>Safety Information</b>		Installing Vertical Operating Pipe . . . . .	15
Understanding Safety-Alert Messages. . . . .	5	Installing Operating Handle . . . . .	16
Following Safety Instructions . . . . .	5	Installing Key Interlock . . . . .	18
Replacement Instructions and Labels . . . . .	5	Checking Alignment . . . . .	19
Location of Safety Labels. . . . .	6	Checking Operation . . . . .	20
<b>Safety Precautions</b> . . . . .	7	Connecting High-Voltage Conductors . . . . .	23
<b>Shipping and Handling</b>		<b>Operation</b>	
Inspection . . . . .	8	Opening and Closing the Switch . . . . .	24
Packing . . . . .	8		
Handling . . . . .	8		



## Introduction

---

### Qualified Persons

#### **WARNING**

The equipment covered by this publication must be installed, operated, and maintained by qualified persons who are knowledgeable in the installation, operation, and maintenance of overhead electric power distribution equipment along with the associated hazards. A Qualified Person is someone who is trained and competent in:

- The skills and techniques necessary to distinguish exposed live parts from nonlive parts of electrical equipment
- The skills and techniques necessary to determine the proper approach distances corresponding to the voltages to which the Qualified Person will be exposed
- The proper use of special precautionary techniques, personal protective equipment, insulated and shielding materials, and insulated tools for working on or near exposed energized parts of electrical equipment

These instructions are intended **ONLY** for such Qualified Persons. They are not intended to be a substitute for adequate training and experience in safety procedures for this type of equipment.

### Read this Instruction Sheet

#### **NOTICE**

Read this instruction sheet thoroughly and carefully before installing or operating your S&C Alduti-Rupter Switch. Familiarize yourself with the Safety Information and Safety Precautions on pages 5 through 7.

### Retain this Instruction Sheet

This instruction sheet is a permanent part of your S&C Alduti-Rupter Switch. Designate a location where you can easily retrieve and refer to this publication. The latest version of this publication is available online in PDF format at [sandc.com/en/support/product-literature/](http://sandc.com/en/support/product-literature/).

## Proper Application

**⚠ WARNING**

The equipment in this publication must be selected for a specific application. The application must be within the ratings furnished for the equipment. Refer to S&C Specification Bulletin 761-31 for complete application information.

In most applications, Alduti-Rupter Switches are capable of switching rated continuous load currents at full voltage. The ratings for the particular switch are listed on nameplates attached to the operating handle and the switch. See Figure 1.

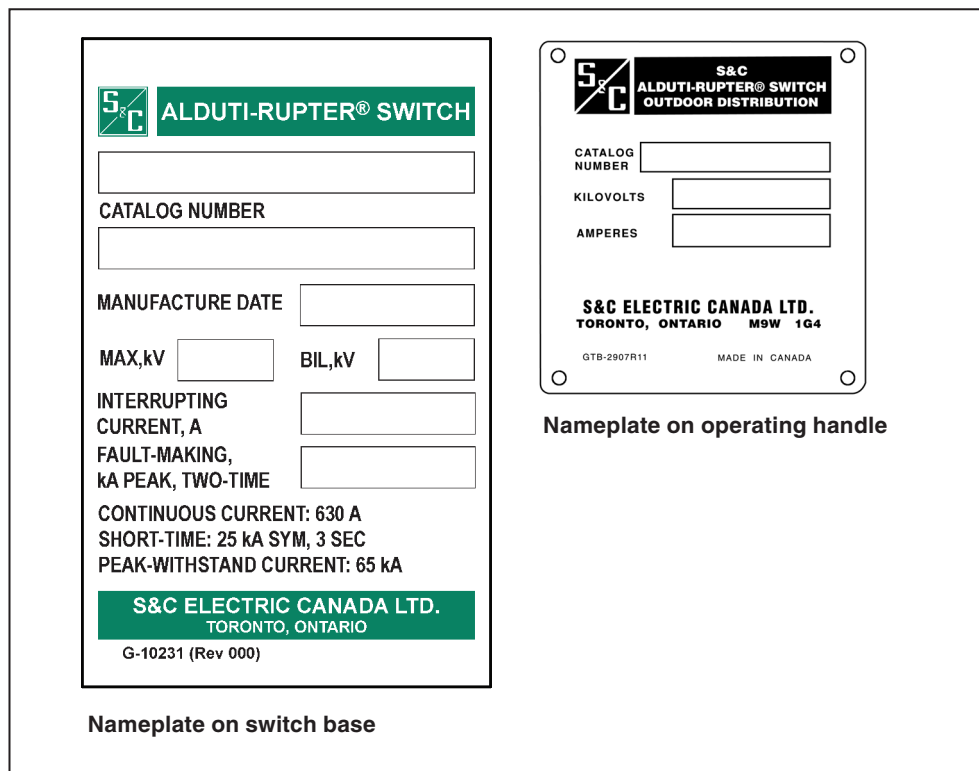

Figure 1. Switch nameplates with ratings

These interrupter switches are not intended for breaking fault currents.

### Warranty

The warranty and/or obligations described in S&C's Price Sheet 150 "Standard Conditions of Sale – Immediate Purchasers in the United States" (or Price Sheet 153, Standard Conditions of Sale – Immediate Purchasers Outside the United States) plus any special warranty provisions, as set forth in the applicable product-line specification bulletin, are exclusive. The remedies provided in the former for breach of these warranties shall constitute the immediate purchaser's or end user's exclusive remedy and a fulfillment of the seller's entire liability. In no event shall the seller's liability to the immediate purchaser or end user exceed the price of the specific product that gives rise to the immediate purchaser's or end user's claim. All other warranties, whether express or implied or arising by operation of law, course of dealing, usage of trade or otherwise, are excluded. The only warranties are those stated in Price Sheet 150 (or Price Sheet 153), and THERE ARE NO EXPRESS OR IMPLIED WARRANTIES OF MERCHANTABILITY OR FITNESS FOR A PARTICULAR PURPOSE. ANY EXPRESS WARRANTY OR OTHER OBLIGATION PROVIDED IN PRICE SHEET 150 (OR PRICE SHEET 153) IS GRANTED ONLY TO THE IMMEDIATE PURCHASER AND END USER, AS DEFINED THEREIN. OTHER THAN AN END USER, NO REMOTE PURCHASER MAY RELY ON ANY AFFIRMATION OF FACT OR PROMISE THAT RELATES TO THE GOODS DESCRIBED HEREIN, ANY DESCRIPTION THAT RELATES TO THE GOODS, OR ANY REMEDIAL PROMISE INCLUDED IN PRICE SHEET 150 (or PRICE SHEET 153.)

### Warranty Qualifications

The standard warranty is applicable to the S&C Alduti-Rupter Switch detailed in this instruction sheet except when it is power operated using a switch operator of other than S&C manufacture.

**Understanding Safety-Alert Messages**

Several types of safety-alert messages may appear throughout this instruction sheet and on labels and tags attached to your S&C Alduti-Rupter Switch. Familiarize yourself with these types of messages and the importance of these various signal words:

<b>⚠ DANGER</b>
“DANGER” identifies the most serious and immediate hazards that will likely result in serious personal injury or death if instructions, including recommended precautions, are not followed.
<b>⚠ WARNING</b>
“WARNING” identifies hazards or unsafe practices that can result in serious personal injury or death if instructions, including recommended precautions, are not followed.
<b>⚠ CAUTION</b>
“CAUTION” identifies hazards or unsafe practices that can result in minor personal injury if instructions, including recommended precautions, are not followed.
<b>NOTICE</b>
“NOTICE” identifies important procedures or requirements that can result in product or property damage if instructions are not followed.

**Following Safety Instructions**

If you do not understand any portion of this instruction sheet and need assistance, contact your nearest S&C Sales Office or S&C Authorized Distributor. Their telephone numbers are listed on S&C’s website sandc.com, or call the S&C Global Monitoring and Support Center at 1-888-762-1100.

<b>NOTICE</b>	
Read this instruction sheet thoroughly and carefully before installing your S&C Alduti-Rupter Switch.	

**Replacement Instructions and Labels**

If needing additional copies of this instruction sheet, contact the nearest S&C Sales Office, S&C Authorized Distributor, S&C Headquarters, or S&C Electric Canada Ltd.

It is important that any missing, damaged, or faded labels on the equipment be replaced immediately. Replacement labels are available by contacting your nearest S&C Sales Office, S&C Authorized Distributor, S&C Headquarters, or S&C Electric Canada Ltd.

# Safety Information

## Location of Safety Labels

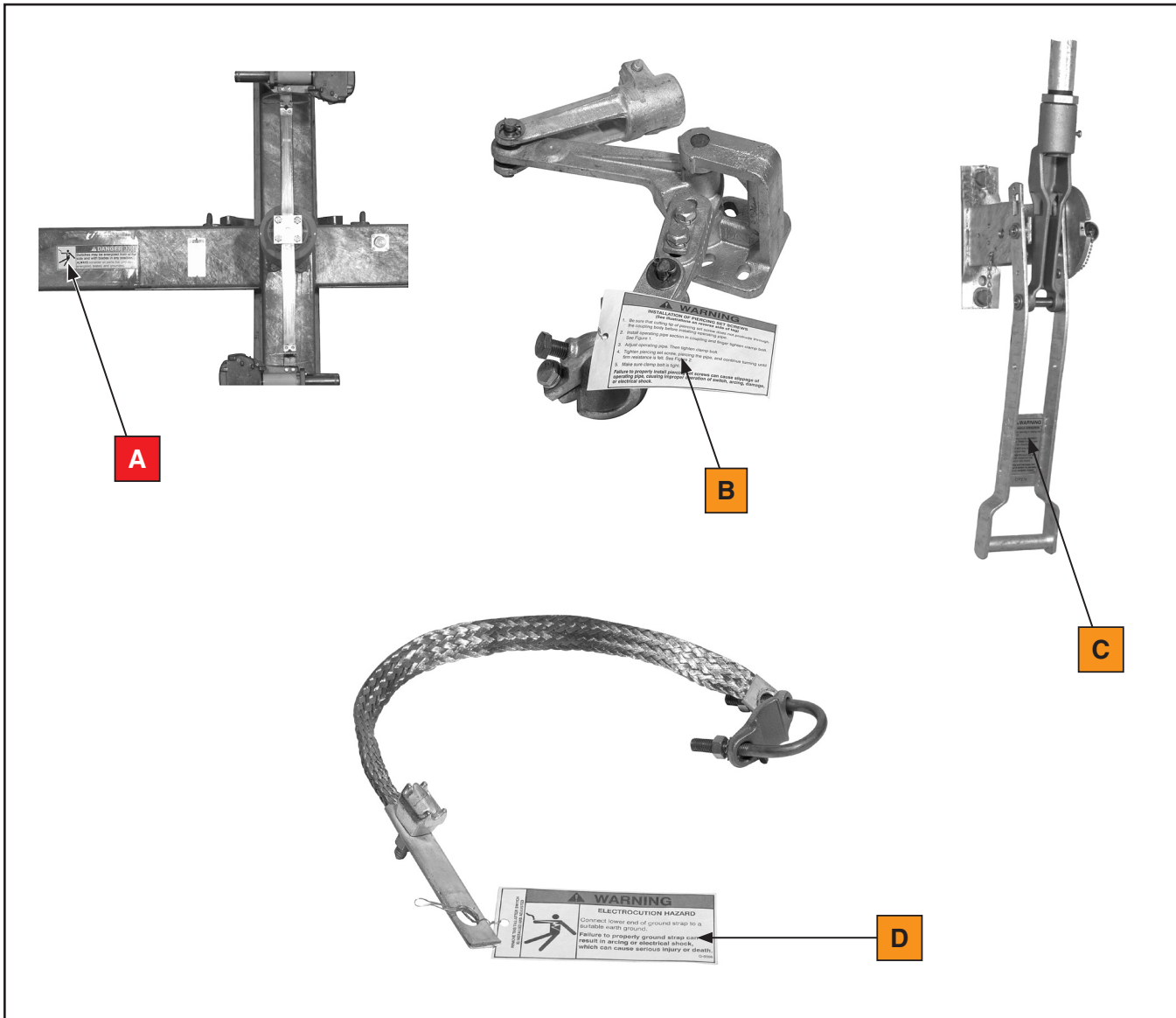

### Reorder Information for Safety Information

Location	Safety Alert Message	Description	Part Number
A	<b>⚠ DANGER</b>	Electrocution Hazard	●
B	<b>⚠ WARNING</b>	Piercing Set Screws	G-3176R1■
C	<b>⚠ WARNING</b>	Handle Operation	G-4400R5
D	<b>⚠ WARNING</b>	Electrocution Hazard – Grounding Strap	G-6596■

- G-6580-1 on tiered-outboard mounting configuration switch; G-6580-2 on vertical mounting configuration switch.
- This part is a tag which is to be removed and discarded after the switch is installed and adjusted.

**⚠ DANGER**



**Alduti-Rupter Switches operate at high voltage. Failure to observe these precautions will result in serious personal injury or death.**

Some of these precautions may differ from company operating procedures and rules. Where a discrepancy exists, users should follow their company's operating procedures and rules.

- |  |   |
|--|---|
| <ol style="list-style-type: none"> <li><b>1. QUALIFIED PERSONS.</b> Access to switches and controls must be restricted only to qualified persons. See "Qualified Persons" on page 2.</li> <li><b>2. SAFETY PROCEDURES.</b> Always follow safe operating procedures and rules.</li> <li><b>3. PERSONAL PROTECTIVE EQUIPMENT.</b> Always use suitable protective equipment such as rubber gloves, rubber mats, hard hats, safety glasses, and flash clothing in accordance with safe operating procedures and rules.</li> <li><b>4. SAFETY LABELS AND TAGS.</b> Do not remove or obscure any of the "DANGER," "WARNING," "CAUTION," or "NOTICE" labels and tags. Remove tags ONLY if instructed to do so.</li> </ol> | <ol style="list-style-type: none"> <li><b>5. ENERGIZED COMPONENTS.</b> Always consider all parts live until de-energized, tested, and grounded.</li> <li><b>6. INTERRUPTER SWITCH POSITION.</b> Always confirm the <b>Open/Close</b> position of interrupter switches by visually observing the position of the blades. Switches may be energized from either side and with the blades in any position.</li> <li><b>7. MAINTAINING PROPER CLEARANCE.</b> Always maintain proper clearance from energized components.</li> <li><b>8. OPERATION.</b> Circuit making and breaking is involved in the normal operation of this interrupter switch and, as a result, "partway" opening or closing is undesirable. To operate, swing the operating handle through its full travel vigorously and without hesitation. See "Operation" section on page 24.</li> </ol> |
|--|---|

# Shipping and Handling

## Inspection

Examine the shipment for external evidence of damage as soon after receipt as possible, preferably before removal from the carrier's conveyance. Check the bill of lading to make sure that shipping skids, crates, and containers listed thereon are present. If there is visible loss and/or damage:

- Notify the delivering carrier immediately.
  - Ask for a carrier inspection.
  - Note condition of shipment on all copies of the delivery receipt.
  - File a claim with the carrier.
- If concealed damage is discovered:
- Notify the delivering carrier within 15 days of receipt of shipment.
  - Ask for a carrier inspection.
  - File a claim with the carrier.

Also notify S&C Electric Company in all instances of loss and/or damage.

## Packing

### Standard Mounting Arrangements

Study the erection drawing carefully and check the bill of materials to make sure all of the parts are at hand. When a standard mounting arrangement is specified, the shipment includes:

- A three-pole interrupter switch, complete with interphase drive, factory assembled on a single base (All switch adjustments, including that of the interphase drive, are made at the factory to ensure proper operation and simultaneity of opening and closing.)
- Three vertical operating-pipe sections (Switch may be furnished "less operating pipe," if specified.)
- Operating mechanism components, such as handle, rod guides, and couplings—each tagged and keyed to the bill of material for ready identification

### Standard Minor Modifications

The erection drawing (ED) also indicates the standard minor modifications available for the standard mounting arrangement. The components included with these modifications are shown on the erection drawing under the specified "-SX" suffix. They include:

- S1: 2 $\frac{5}{8}$ -inch (67 mm) diameter tubular fiberglass insulating section in vertical operating shaft
- S2: Cypoxy Insulator in vertical operating shaft
- S6: Key interlock—single lock for "locked-open" application
- S6L: Provision for key interlock—allows future addition of single lock for "locked-open" application

-S7: Auxiliary contact switch with 4 N/O and 4 N/C contacts (600 Vac, 20 A)

-S8: Provision for power operation of pole-mounted switches by S&C Switch Operator—Type AS-10

-S9: Provision for power operation of steel-structure switch by S&C Switch Operator—Type AS-10

-S16: Provision for power operation of pole-mounted switches by S&C 6801M Automatic Switch Operator

"-V1," "-V2," or "-V3" adds (one, two, or three respectively) extra 6-foot-10-inch (208-cm) lengths of pipe and includes the appropriate number of extra couplings and guides.

Drawing RD-1005, detailing the various modifications, is included in addition to the erection drawing.

### Power Operation

If suffix "-S8" or "-S9" is specified, S&C Instruction Sheets 769-510 and 769-511, "S&C Switch Operators—Type AS-10," are included with the switch operator shipment. Instruction Sheets 769-510 and 769-511 cover installation, operation, and adjustment of the switch operator and should be used in conjunction with this instruction sheet where applicable. If suffix "-S16" is specified, associated S&C instruction sheets for the 6801M Automatic Switch Operator are included with the switch operator shipment and should be used in conjunction with this instruction sheet where applicable.

## Handling

The crate the switch is packed in is designed to be moved and lifted using a lift truck. Raised slots in the bottom of the crate are provided for a lift truck's forks.

### NOTICE

To minimize time-consuming final adjustments after installation, make sure the switch poles are in their fully **Closed** position and their toggle mechanisms are against their closed stops during installation of the vertical operating-pipe sections. Switch blades can be tied to their jaw-contact members, and the toggle mechanisms can be tied to their stops.

### ⚠ WARNING

**DO NOT** lift the switch by rigging on the "live parts" or subject these parts to undue stress from slings or fall lines.

Lifting the switch by the live parts will damage the switch. Rough handling may cause damage to the blades, contacts, and/or interrupters.

Failure to lift the switch properly can result in switch damage, causing improper operation, arcing, or electrical shock.

**Mounting to Wood**

**NOTICE**

When mounting to a wood utility pole, a Belleville washer must be used between the square washer and the nut, to maintain fastener tightness in the event of wood shrinkage. See Figure 2.

**Preparing the Pole**

**STEP 1.** Drill two  $\frac{1}{16}$ -inch (21-mm) diameter holes through the utility pole as shown, at the desired height for mounting the switch. See Figure 3. Refer to the erection drawing (ED).

**STEP 2.** Insert a  $\frac{3}{4}$ -inch (19-mm) diameter through-bolt (not furnished) into each hole as shown in Figure 4.

*Loosely* attach a square washer, spring washer (when mounting to a wood utility pole), and nut on each bolt.

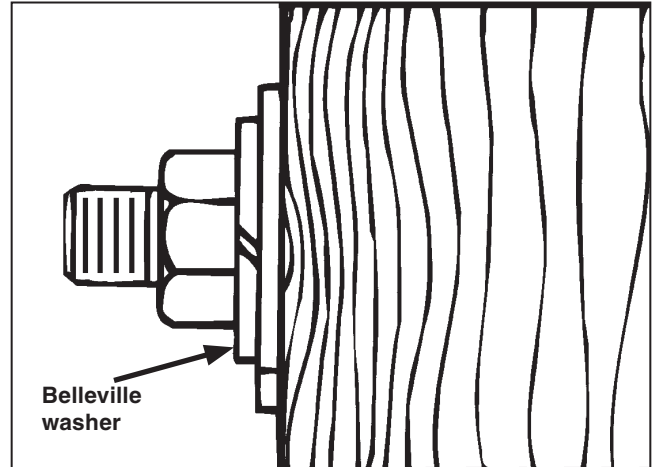

Figure 2. Applying spring washer.

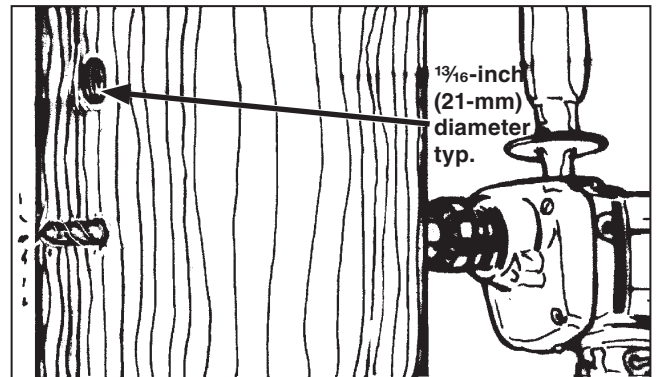

Figure 3. Drilling holes for switch-mounting bracket.

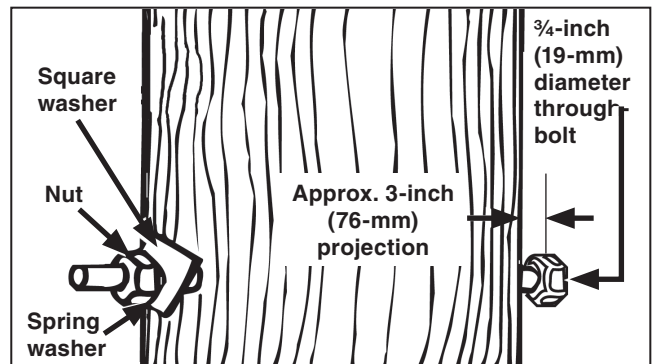

Figure 4. Installing through-bolts.

# Installation

## Uncrating the Switch

**STEP 3.** Remove the switch from its crate. See Figure 5. Protect the bearings from contamination by dirt, mud, oil, etc. If necessary, use blocks to keep the bearings clear of the ground.

For tiered-outboard mounting configuration switches proceed to Step 4 below.

For vertical mounting configuration switches proceed to Step 9 on page 12.

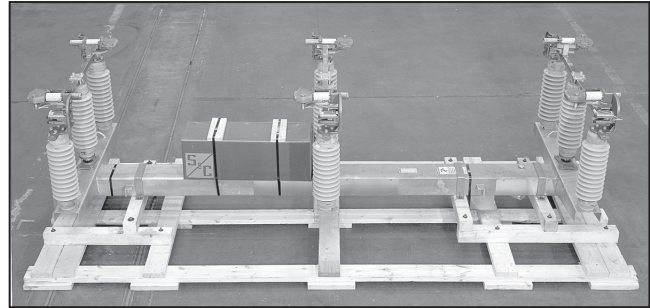

Figure 5. Uncrating the switch.

## Lifting Tiered-Outboard Mounting Configuration Switch

**STEP 4.** To minimize time-consuming final adjustments, make sure that the switch is fully closed. Tie the switch blades to their stationary main contact assemblies. See Figure 6.

**STEP 5.**

### ⚠ WARNING

DO NOT lift the switch by rigging on the “live parts” or subject these parts to undue stress from slings or fall lines.

Lifting the switch by the live parts will damage the switch. Rough handling may cause damage to the blades, contacts, and/or interrupters.

Failure to lift the switch properly can result in switch damage, causing improper operation, arcing, or electrical shock.

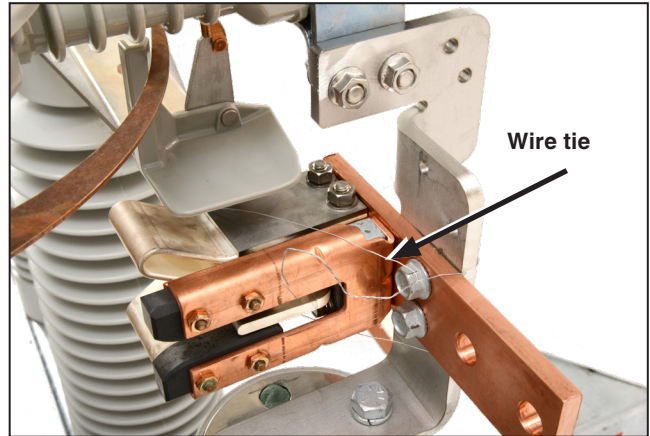

Figure 6. Tying switch blade to main contacts.

Hoist the switch using the two lifting eyes attached to the top switch pole-unit base. See Figure 7.

Unbolt the 4-inch x 4-inch (102-cm x 102-cm) wood frame skid after the switch is hoisted to the vertical position. This frame prevents damage to the live parts of the bottom switch pole, as the switch is being hoisted.

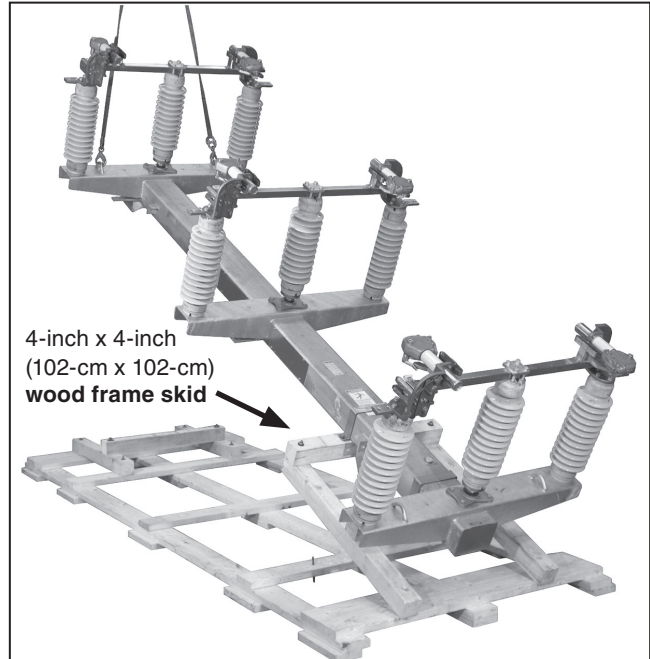

Figure 7. Hoisting switch into position.

**STEP 6.** Guide the switch so that the through-bolt heads enter into the keyhole slot and open slotted hole in the switch base. See Figure 8.

**STEP 7.** Slowly lower the switch, until it just bears on the through-bolts. Fully tighten the bolts. See Figure 9. Then remove the lifting slings.

**STEP 8.** Attach the pole bands to the switch base anchor brackets using the J-bolts furnished. Use a stiffening block under each nut. See Figure 10.

Use a 5/8-inch (16-mm) diameter lag bolt (not furnished) to secure each pole band to the utility pole.

Proceed to the “Installing Pipe Couplings with Piercing Set Screws” section on page 14.



Figure 8. Guiding switch.



Figure 9. Bolting switch.

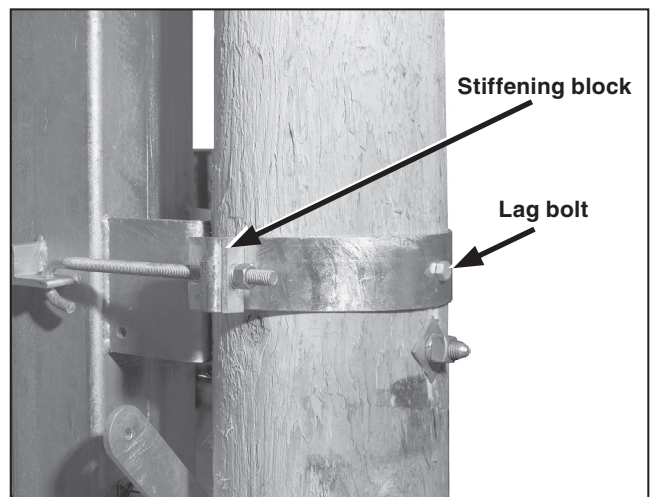

Figure 10. Attaching pole bands.

## Installation

### Lifting Vertical Mounting Configuration Switch

**STEP 9.** To minimize time-consuming final adjustments, make sure that the switch is fully closed. Tie the switch blades to their stationary main contact assemblies. See Figure 11.

**STEP 10.**

#### **⚠ WARNING**

**Do not** lift the switch by rigging to the “live parts,” nor subject these parts to undue stress from slings or fall lines. Misalignment of the contacts and the interrupters may result from improper handling.

The switch will roll somewhat more than 90-degrees as it clears the shipping skid.

Hoist the switch using the two lifting eyes attached to the outboard switch pole-unit bases. See Figure 12.

Unbolt the 4-inch x 4-inch (102-cm x 102-cm) wood blocks attached to the switch base after the switch is hoisted to the vertical position. These blocks prevent damage to the lower live parts of the switch, as the switch is being hoisted.

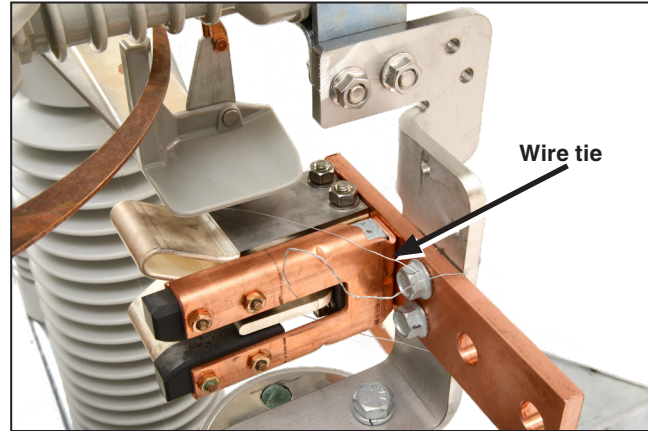

Figure 11. Tying switch blade to main contacts.

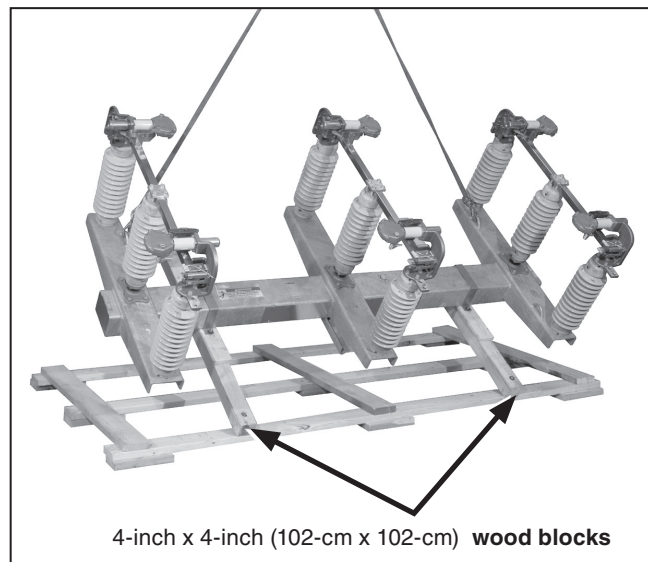

Figure 12. Hoisting switch into position.

**STEP 11.** Guide the switch so that the through-bolt heads enter into the keyhole slot and open slotted hole in the switch base. See Figure 13.

**STEP 12.** *Slowly* lower the switch, until it just bears on the through-bolts. Fully tighten the bolts. See Figure 14. Then remove the lifting slings.



Figure 13. Guiding switch.

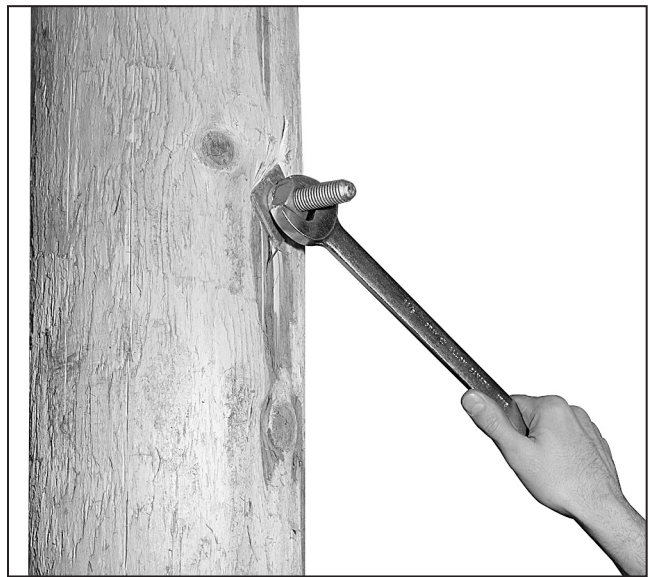

Figure 14. Bolting switch.

## Installation

**STEP 13.** Attach the pole bands to the switch base anchor brackets using the J-bolts furnished. Use a stiffening block under each nut. See Figure 15.

Use a 5/8-inch (16-mm) diameter lag bolt (not furnished) to secure each pole band to the utility pole.

### Installing Pipe Couplings with Piercing Set Screws

#### **⚠ WARNING**

Failure to properly install pipe couplings with piercing set screws can cause slippage of operating pipe, resulting in improper operation of the switch, arcing, equipment damage, or electrical shock.

To properly install piercing set screws:

1. Make sure that the cutting tip of the piercing set screw does not protrude through the body of the clamp.
2. Insert the operating pipe section into the coupling and finger-tighten the clamp bolt(s).
3. Adjust the operating pipe to the correct length. Then tighten the clamp bolt(s) to final tightness.
4. Tighten the piercing set screw, piercing the pipe, and continue turning until a firm resistance is felt. Make sure that the clamp bolt(s) are tight.

See Figure 16.

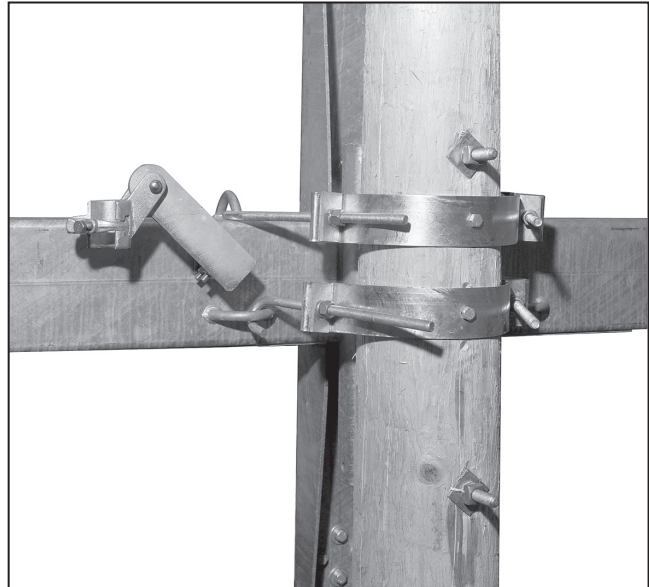

Figure 15. Attaching pole bands.

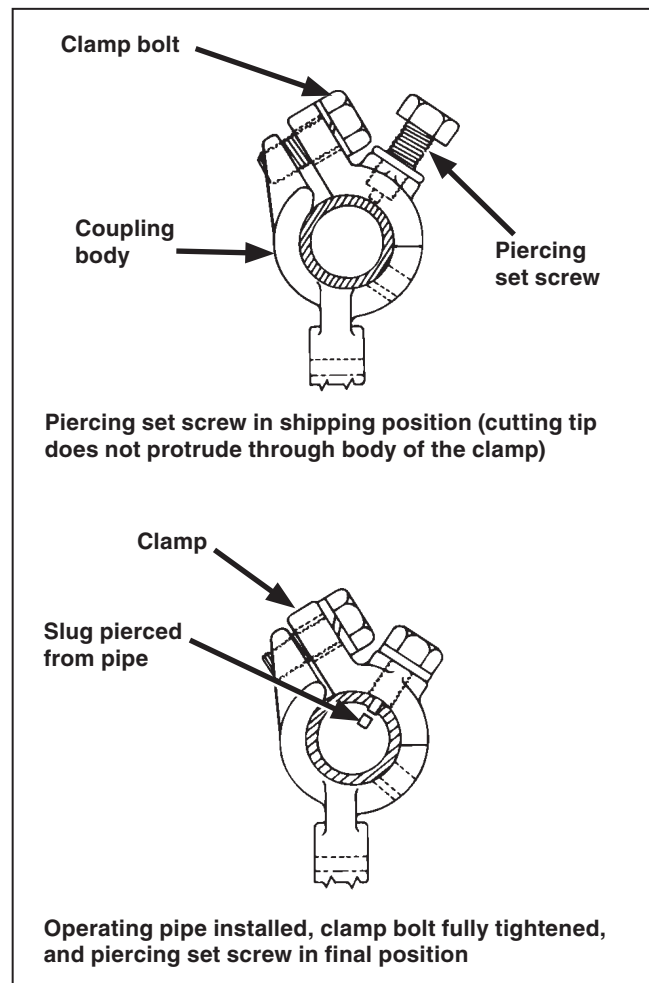

Figure 16. Installing pipe couplings.

### Installing Vertical Operating Pipe

**STEP 14.** One of the pipe sections furnished is threaded at one end to accommodate the operating handle assembly. See Figure 17. Install this section of pipe last, with the threads at the lower end.

If only one vertical operating-pipe section is required, proceed to Step 17 on page 16.

**STEP 15.** Mount the rod guide(s) with the arm pointing upward as shown in Figure 18.

When an adjustable rod guide is included mount it nearest the switch.

**STEP 16.** Install the upper section of vertical operating pipe between the switch drive lever and the uppermost rod guide, with the rod-guide arm pointing upward at a 45-degree angle. See Figure 19. (A positioning stud is furnished which holds the rod guide at 45 degrees.) Follow the directions in the “Installing Pipe Couplings with Piercing Set Screws” section on page 14.

Torque the clamp bolts to final tightness. Then tighten the piercing set screws, piercing the pipe, and continue turning until a firm resistance is felt.

If more than one rod guide is used, install vertical operating-pipe sections between the rod guides in the same manner.



Figure 17. Threaded vertical operating pipe.

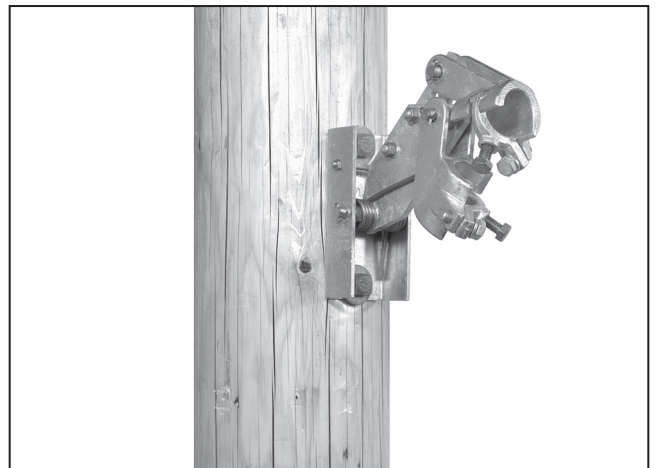

Figure 18. Attaching rod guide.

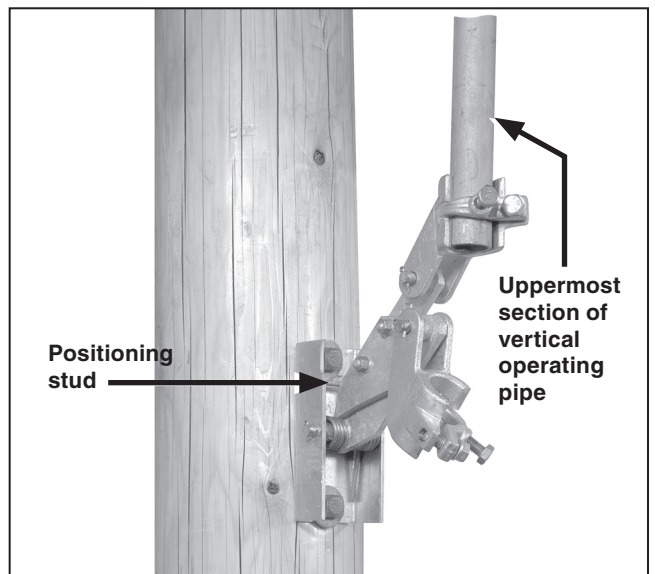

Figure 19. Installing upper operating pipe section into rod guide.

## Installing Operating Handle●

**STEP 17.** Mount the operating handle assembly as shown on the erection drawing (ED). At the same time, use one of the mounting bolts to attach one end of the ground strap (the end with the grounding connector attached) to the handle mounting plate. ■ See Figure 20.

**STEP 18.** Install the lowest vertical operating-pipe section by threading one end of the pipe into the coupling on the operating handle assembly. Approximately ¼-inch (6-mm) of thread should extend through the coupling. Tighten the locknut. See Figure 21.

● If suffix “-S8” or “-S9” is specified, refer instead to S&C Instruction Sheet 769-510, “S&C Switch Operators—Type AS-10.” If suffix “-S16” is specified, refer instead to S&C Instruction Sheet 1045M-510, “S&C 6801M Automatic Switch Operators.”

■ The grounding recommendations herein may differ from the standard operating and safety procedures of certain electric utility companies. Where a discrepancy exists, the operating procedures of the electric utility apply.

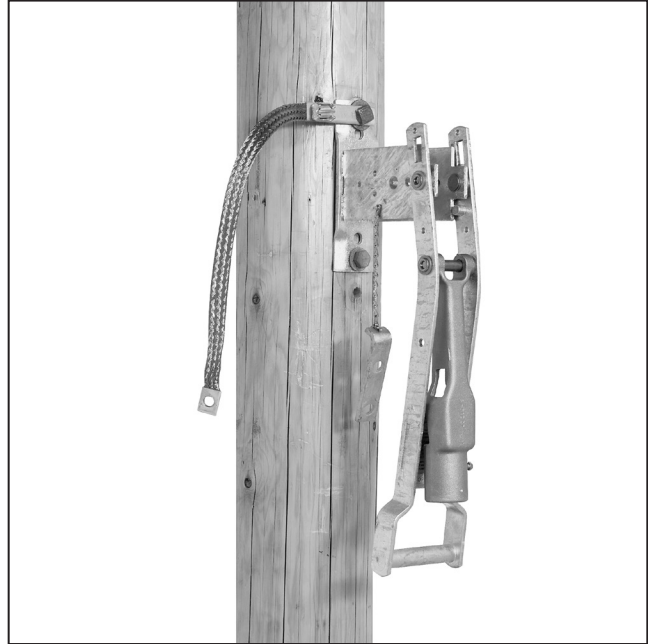

Figure 20. Mounting operating handle.

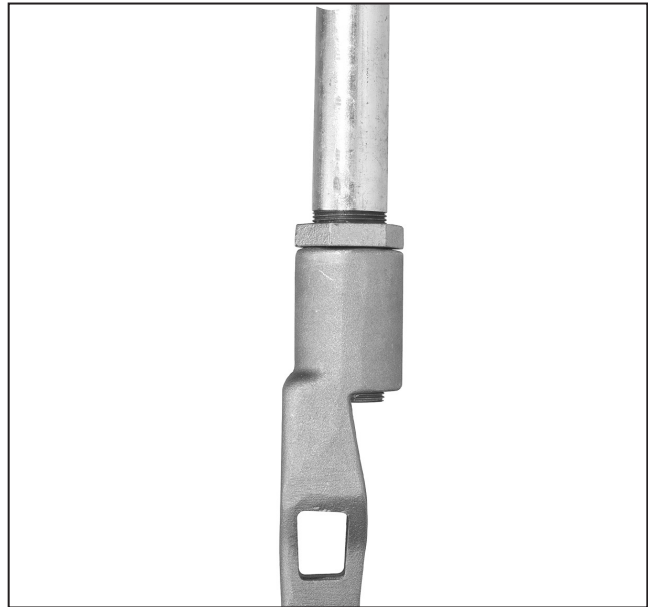

Figure 21. Installing lowest operating pipe section into operating handle assembly.

**STEP 19.** Insert the upper end of this pipe section in the lowest rod guide or—if only one vertical operating-pipe section is used—the offset coupling attached to the switch drive lever and, while holding the operating handle at a point approximately 20 degrees from the closed position, torque the rod guide (or switch drive lever) coupling clamp bolt. See Figure 22.

### NOTICE

Do not tighten the piercing set screw at the top of the lowest section of vertical operating-pipe until satisfactory operating handle adjustment is attained.

**STEP 20.** Fasten the free end of the grounding strap to the lowest vertical operating-pipe section a few inches above the operating handle assembly with the U-bolt connector provided for this purpose. See Figure 23. Then connect the lower end of the strap to a suitable earth ground, using the grounding connector provide at that end of the strap.●

Skip to Step 23 on page 19.

● The grounding recommendations herein may differ from the standard operating and safety procedures of certain electric utility companies. Where a discrepancy exists, the operating procedures of the electric utility apply.

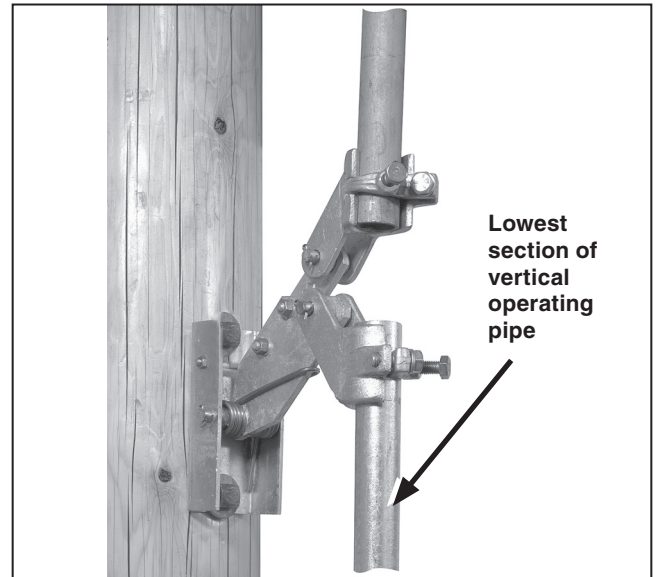

Figure 22. Installing lowest operating pipe section into rod guide

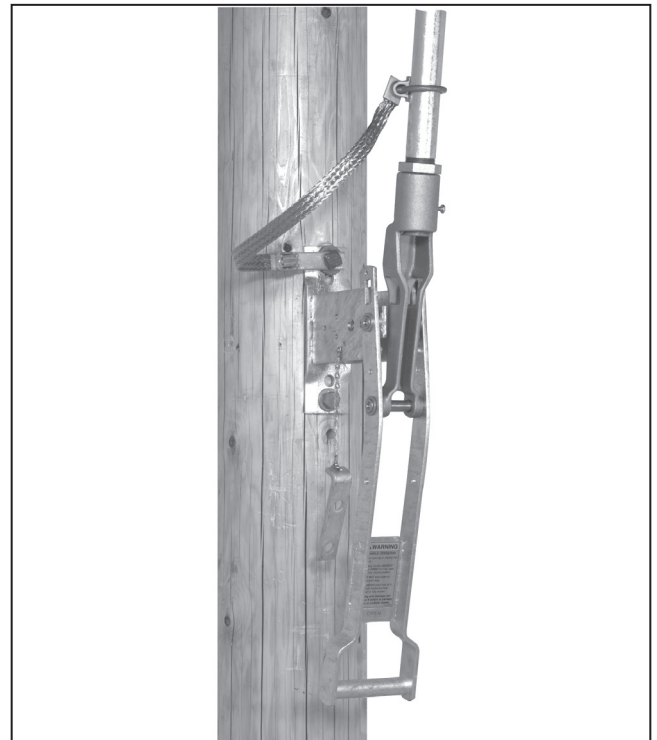

Figure 23. Attaching grounding strap.

## Installation

### Installing Key Interlock

**STEP 21.** The interlock group includes a Superior Type B4003-1 Mk II single- or multiple-key interlock (or equivalent), with zero bolt projection and 3/4-inch (19-mm) bolt travel, locking disc, and interlock bracket. If “provision only” is specified, the interlock is not included.

Attach the key interlock to the interlock bracket so that the interlock bolt, when extended, engages a slot in the locking disc on the operating handle. See Figure 24.

**STEP 22.** Block one of the two slots in the locking disc with the blocking screw provided. (The slot to be blocked depends on whether a locked-open or locked-closed arrangement is required.) See Figure 25.

#### NOTICE

Key interlocks are intended for proper sequencing of switch operations; they are not intended to provide security. The operating handle assembly includes a locking bar for padlocking the switch in either the open or closed position.

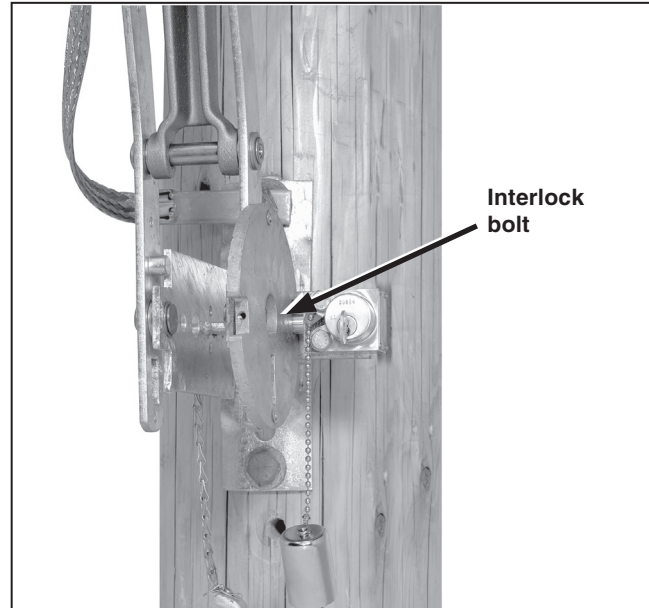

Figure 24. Attaching key interlock to interlock bracket.

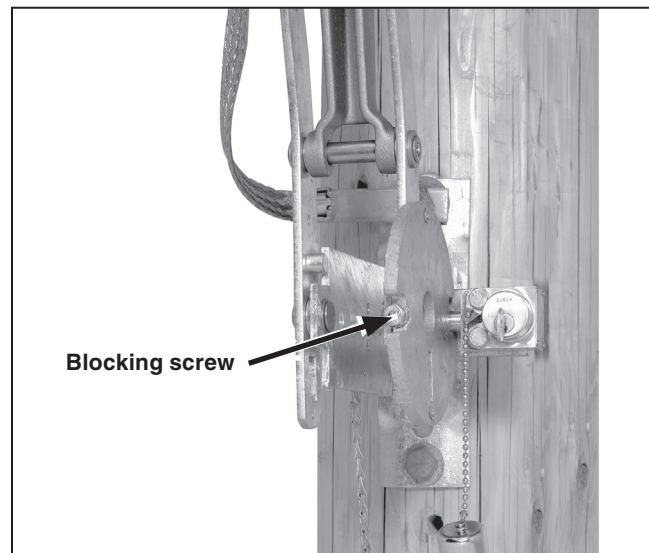

Figure 25. Blocking slot in interlock disc.

## Checking Alignment

**STEP 23.** Remove the ties holding the switch blades to their stationary main contact assemblies. See Figure 26.

Remove the 45-degree positioning stud from each rod guide. See Figure 19 on page 15.

Open and close the switch slowly to ensure that no operational difficulties are encountered due to undetected damage in shipping.

### ⚠ WARNING

Open and close the switch slowly **ONLY** when checking the operation or making adjustments to the de-energized switch.

When opening or closing an energized switch, swing the operating handle vigorously through its full travel without hesitation.

Arcing and damage to the switch will occur if the energized switch is operated slowly or left in the partially **Open** or **Closed** position.

**STEP 24.** Move the operating handle *slowly* to the closed position. See Figure 27. A definite resistance should be felt at the end of the stroke, indicating that all slack in the operating linkage has been taken up.

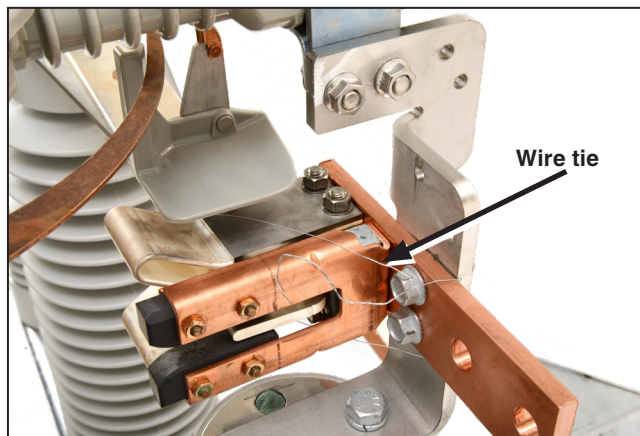

Figure 26. Removing tie at stationary main contact assembly.

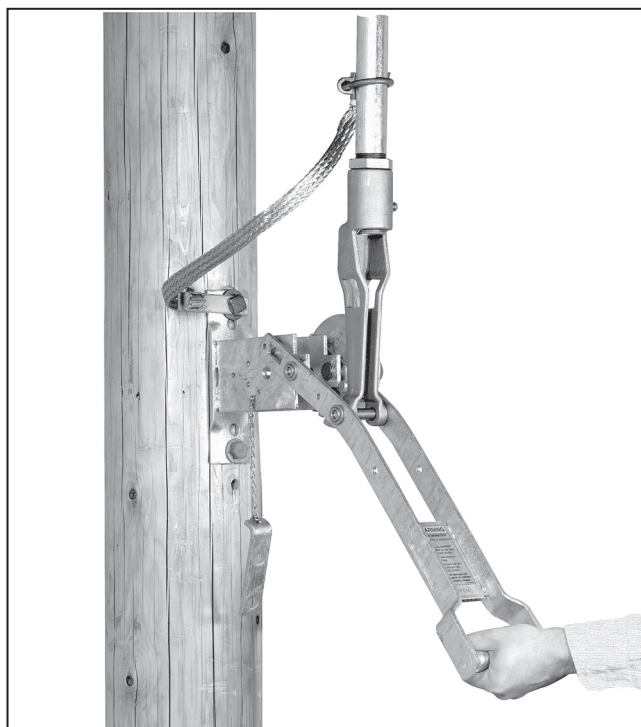

Figure 27. Verifying slack has been taken up in operating linkage.

## Installation

**STEP 25.** If there is still slack, repeat the procedure in Step 19 but move the operating handle *more* than 20 degrees in the opening direction before torquing the clamp bolt on the lowest rod guide (or switch drive lever) coupling. See Figure 28.

Conversely, if considerable force is needed to move the handle to the fully closed position, or if the handle does not swing 180 degrees to the fully open position, loosen the clamp bolt on the lowest rod guide (or switch drive lever) coupling, and move the handle to a position *less* than 20 degrees from the closed position. Then torque the clamp bolt on the lowest rod guide (or switch drive lever) coupling. Proper “resistance” in the operating linkage is essential to ensure positive switch closure.

Recheck to be sure that all clamp bolts and piercing set screws have been torqued to final tightness.

### Checking Operation

#### **⚠ WARNING**

Open and close the switch slowly **ONLY** when checking the operation or making adjustments to the de-energized switch.

When opening or closing an energized switch, swing the operating handle vigorously through its full travel without hesitation.

Arcing and damage to the switch will occur if the energized switch is operated slowly or left in the partially **Open** or **Closed** position.

**STEP 26.** Check to be sure that the following conditions exist:

- With the operating handle as far as it will go in the opening direction, the switch blades are 90 degrees from the Closed position (perpendicular to the channel base). See Figure 29.
- With the operating handle as far as it will go in the closing direction, the blade of each switch pole is fully closed and within 1/8-inch (3 mm) of the stop on both stationary contact assemblies. See Figure 30.

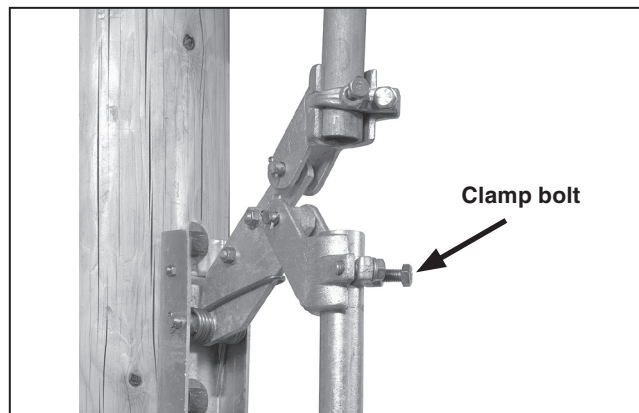

**Figure 28.** Torquing clamp bolt at lowest rod guide (or switch operating lever) coupling.

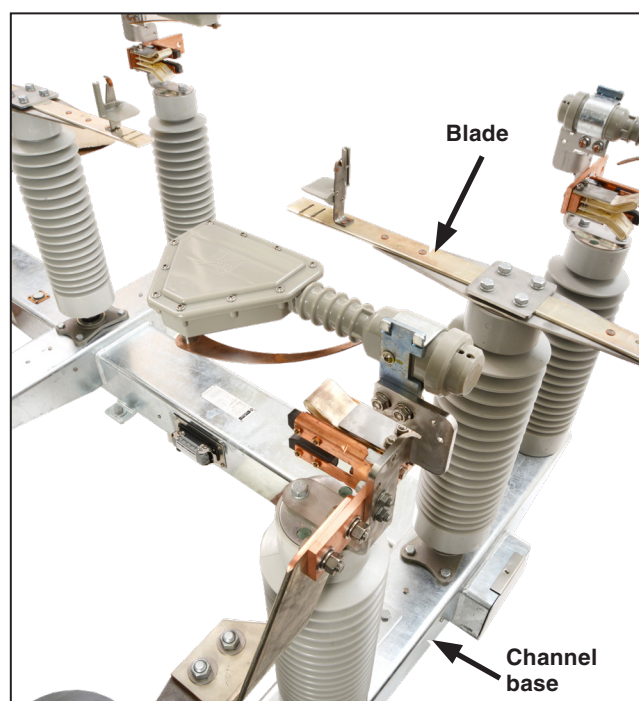

**Figure 29.** The blade at 90 degrees from the channel-base position.

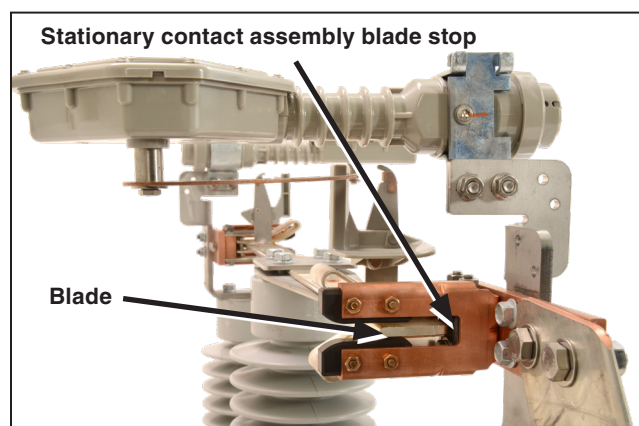

**Figure 30.** Check that the blade is fully closed and within 1/8-inch (3 mm) of the stop on the stationary contact assembly.

In the unlikely event the above-described conditions are not met, more switch blade travel is required. Move the operating handle to its mid-position to take the strain off the operating-pipe linkage and loosen the two bolts that clamp the driven arm of the adjustable rod guide. See Figure 31.

Lengthen the driven arm of the adjustable rod guide one step ( $\frac{1}{32}$  inch) and retighten the bolts. Lengthening the driven arm increases switch-blade travel. Then readjust for full operating handle travel as described on pages 18 and 19.

Repeat this procedure—lengthening the driven arm of the adjustable rod guide in one-step increments and readjusting for full operating handle travel—until full switch-blade travel is attained.

When satisfactory travel adjustment of the operating handle and switch have been attained, torque the bolts on the driven arm of the adjustable rod guide, and the clamp bolt on the rod guide (or switch drive lever) coupling to final tightness. Then tighten the associated piercing set screw, piercing the pipe, and continue turning until a firm resistance is felt.

**STEP 27.** Check the following on each phase:

<b>⚠ WARNING</b>
Open and close the switch slowly <b>ONLY</b> when checking the operation or making adjustments to the de-energized switch.
When opening or closing an energized switch, swing the operating handle vigorously through its full travel without hesitation.
Arcing and damage to the switch will occur if the energized switch is operated slowly or left in the partially <b>Open</b> or <b>Closed</b> position.

- (a) Open and close the switch and examine the interrupter and blade alignment. The interrupter and interrupter shunt arm must be parallel to the sweep of the blade. See Figure 32.
- (b) Slowly open the switch. The following conditions should be met:
  - As the blade moves toward the open position, the operating cam shunt contacts should engage the interrupter shunt arms on the copper-bronze contact surfaces of each shunt contact. See Figure 33.
  - As the blades move in the opening direction the interrupters on each switch pole should actuate within  $\frac{1}{4}$ -inch (6-mm) blade travel.
  - As the blade reaches its full travel the interrupter shunt arms will be released and will quickly snap back to their closed positions and reset for the next operation. See Figure 32.

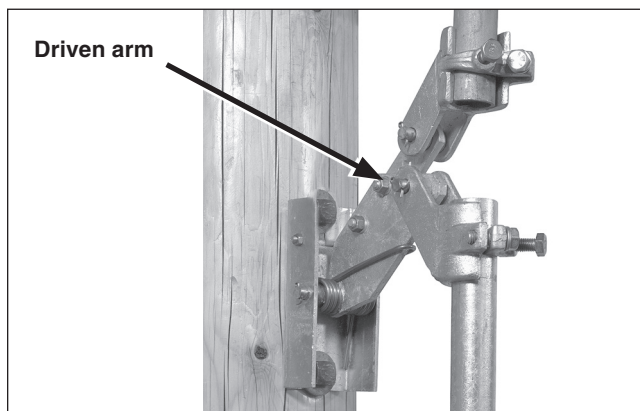

Figure 31. Lengthening driven arm of adjustable rod guide.

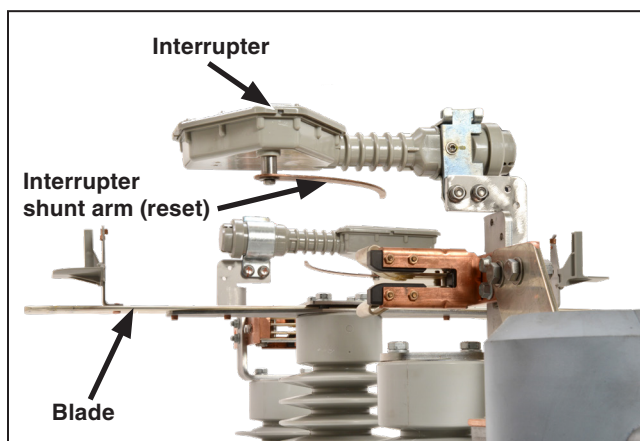

Figure 32. Make sure the interrupter and interrupter shunt arm is parallel to the sweep of the blade.

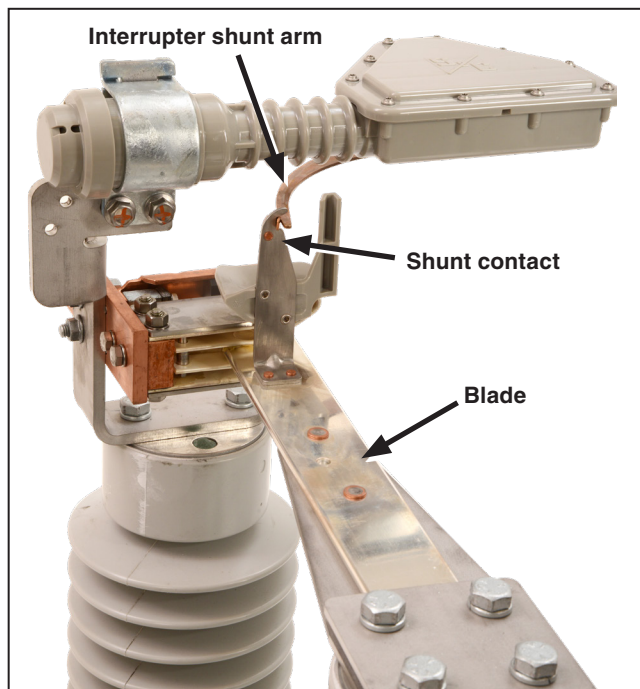

Figure 33. The shunt contacts should engage each interrupter shunt arm on the copper-bronze contact surface of each shunt contact.

## Installation

- (c) Slowly close the switch. The following conditions should be met:
- The interrupter shunt arms should be guided into position by the curved backs of the shunt contacts. See Figure 34.
  - The blades should move into each stationary contact assembly on center. See Figure 35.
  - When the switch is fully closed, the interrupter shunt arms are resting against or are no more than  $\frac{1}{8}$ -inch (3 mm) away from the auxiliary return arm of the multipurpose operating cam. See Figure 36.

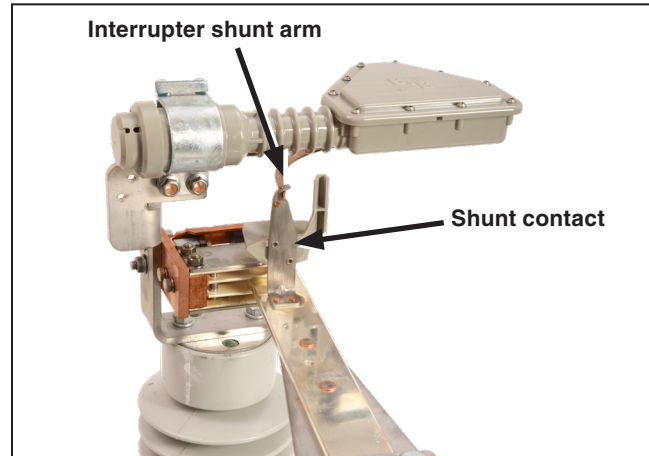

Figure 34. The shunt contacts guide each interrupter shunt arm into position.

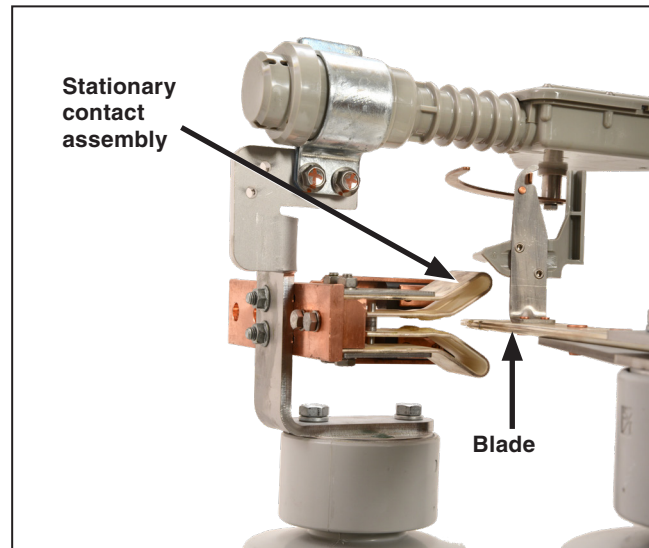

Figure 35. During closing, make sure the blade enters the stationary contact assembly on center.

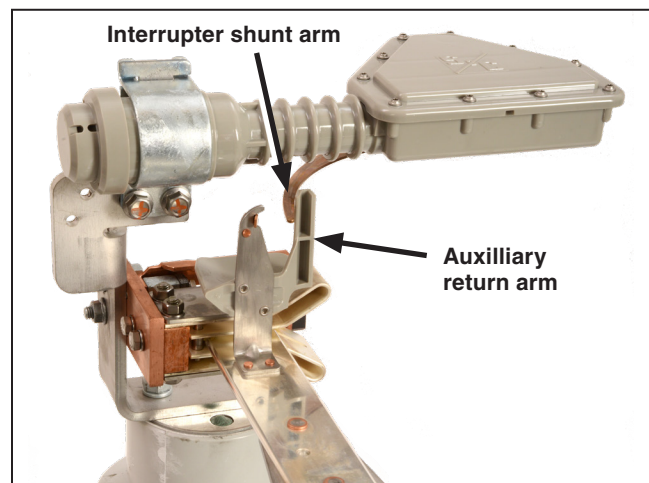

Figure 36. The interrupter shunt arm should be resting against or no more than  $\frac{1}{8}$ -inch (3.2 mm) away from the auxiliary return arm.

## Connecting High-Voltage Conductors

**STEP 28.** When high-voltage conductors are to be connected using aluminum-alloy body connectors●, the following procedures should be used:

- (a) Thoroughly wire-brush the current-transfer surfaces of each connector and immediately apply a liberal coating of Penetrox® A (available from Burndy Corporation) to the brushed surfaces.
- (b) Wire-brush each terminal pad of the switch and apply a coating of Penetrox A. Then, bolt the connectors to the terminal pads.
- (c) Prepare the conductors using established procedures and clamp them in their respective connectors.

● “Mass anode” type connectors, such as the Catalog Number 5300 series offered by S&C, which have been designated by the connector manufacturer as being suitable for direct attachment to copper-bearing alloy terminal pads.

## Opening and Closing the Switch

### **⚠ DANGER**

The interrupters and terminal pads of the Alduti-Rupter Switch may be energized with the interrupters in any position. Before inspecting, servicing, or repairing this switch or working on the conductors on either side of the switch, test for voltage using proper high-voltage test equipment. Then install suitable grounding equipment. Failure to observe these precautions may result in serious injury or death.

### **NOTICE**

This interrupter switch is not intended for breaking fault currents.

**STEP 29.** Remove the padlock from the locking bar on the operating handle assembly. Withdraw the locking bar. See Figure 37.

**STEP 30.** If the operating handle assembly is furnished with a key interlock, disengage the interlock bolt.

**STEP 31.** Swing the handle rapidly to the fully open or fully **Closed** position. See Figure 38. Always check that all three poles are fully open or fully closed.

**STEP 32.** Replace the locking bar and the padlock. Engage the key interlock, if applicable.

### **⚠ WARNING**

Open and close the switch slowly **ONLY** when checking the operation or making adjustments to the de-energized switch.

When opening or closing an energized switch, swing the operating handle vigorously through its full travel without hesitation.

Arcing and damage to the switch will occur if the energized switch is operated slowly or left in the partially **Open** or **Closed** position.

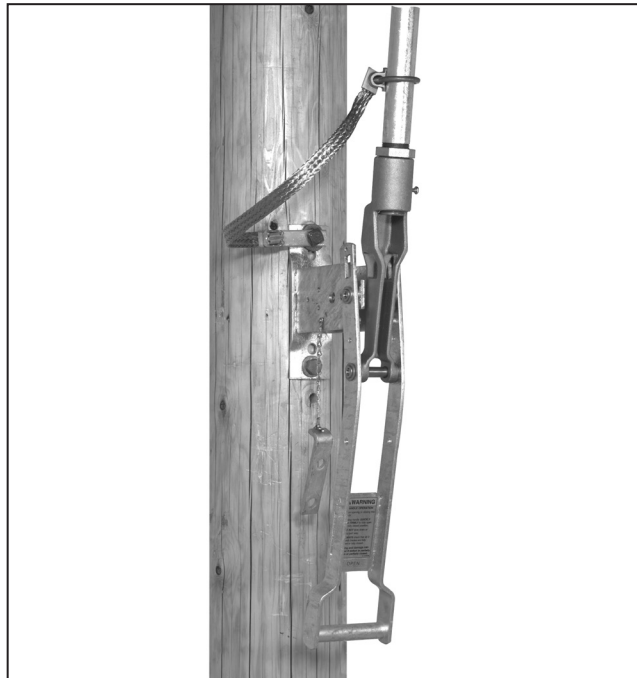

Figure 37. Withdrawing locking bar and disengaging key interlock bolt.

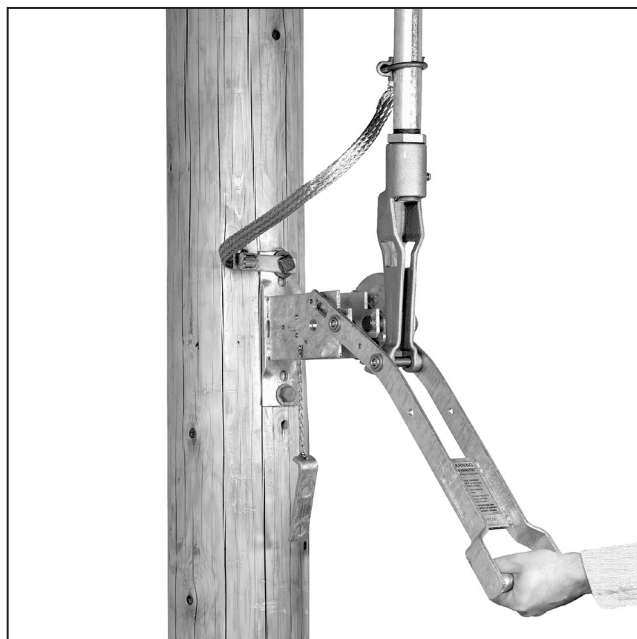

Figure 38. Swing the operating handle rapidly.