

# Installation and Operation

## Table of Contents

Section	Page	Section	Page
<b>Introduction</b>		<b>Preparing the Wood Pole</b>	
Qualified Persons . . . . .	2	Pole-Top Mounting Configuration Switch . . . . .	8
Read this Instruction Sheet . . . . .	2	Upright Mounting Configuration Switch . . . . .	9
Retain this Instruction Sheet. . . . .	2	<b>Installation</b>	
Proper Application . . . . .	2	Uncrating the Switch. . . . .	10
Operating Considerations. . . . .	3	Lifting Pole-Top Mounting Configuration Switch. . . . .	10
Warranty . . . . .	3	Lifting Upright Mounting Configuration Switch. . . . .	13
Warranty Qualifications . . . . .	3	Lifting Pedestal Mounting Configuration Switch. . . . .	15
<b>Safety Information</b>		Installing Pipe Couplings with Piercing Set Screws . . . . .	16
Understanding Safety-Alert Messages. . . . .	4	Installing the Vertical Operating Pipe . . . . .	17
Following Safety Instructions . . . . .	4	Installing Operating Handle . . . . .	20
Replacement Instructions and Labels . . . . .	4	Installing Operating Handle with Key Interlock. . . . .	22
Location of Safety Labels. . . . .	5	Checking Alignment and Adjusting the Stop Plates . . . . .	25
<b>Safety Precautions</b> . . . . .	6	Checking Operation . . . . .	27
<b>Shipping and Handling</b>		Connecting High-Voltage Conductors . . . . .	30
Inspection . . . . .	6	<b>Operation</b>	
Packing . . . . .	7	Opening and Closing the Switch . . . . .	31
Handling . . . . .	7		



# Introduction

## Qualified Persons

**⚠ WARNING**

The equipment covered by this publication must be installed, operated, and maintained by qualified persons who are knowledgeable in the installation, operation, and maintenance of overhead electric power distribution equipment along with the associated hazards. A qualified person is one who is trained and competent in:

- The skills and techniques necessary to distinguish exposed live parts from nonlive parts of electrical equipment
- The skills and techniques necessary to determine the proper approach distances corresponding to the voltages to which the qualified person will be exposed
- The proper use of the special precautionary techniques, personal protective equipment, insulating and shielding materials, and insulated tools for working on or near exposed energized parts of electrical equipment

These instructions are intended only for such qualified persons. They are *not* intended to be a substitute for adequate training and experience in safety procedures for this type of equipment.

## Read this Instruction Sheet

**NOTICE**

Read this instruction sheet thoroughly and carefully before installing or operating your S&C Alduti-Rupter Switch. Familiarize yourself with the Safety Information and Safety Precautions on pages 4 through 6. The latest version of this publication is available online in PDF format at [sandc.com/Support/Product-Literature.asp](http://sandc.com/Support/Product-Literature.asp).

## Retain this Instruction Sheet

This instruction is a permanent part of your Alduti-Rupter Switch. Designate a location where you can easily retrieve and refer to this publication.

## Proper Application

**⚠ WARNING**

The equipment in this publication must be selected for a specific application. The application must be within the ratings furnished for the equipment. Ratings and other application information can be found in Specification Bulletin 761-31.

These interrupter switches are capable of switching rated continuous load currents at full voltage. No interlocking with secondary protective equipment is required. The ratings for the switch are listed on the nameplate. See Figure 1.

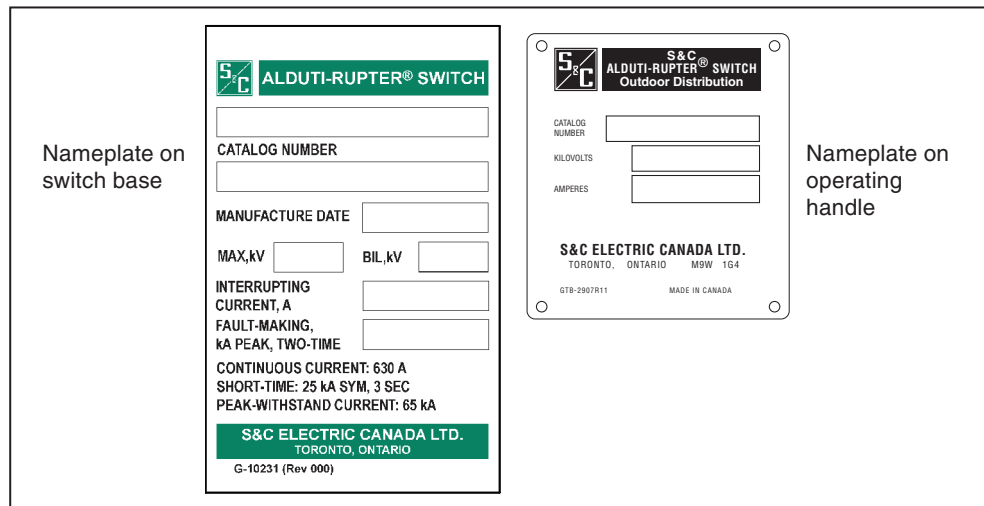

Figure 1. Switch nameplates with ratings.

### Operating Considerations

Circuit making and breaking are involved in the normal operation of these interrupter switches, and partial or precautionary opening or closing of the switch should not be attempted. If the switch is covered in ice or snow, do not “chop” the switch between the **Open** and **Closed** position to dislodge the ice.

To operate the switch, swing the handle through its full stroke without hesitation. Do not assume the operating handle position indicates the **Open** or **Closed** position of the interrupter switch blades. After opening or closing the switch, always make a visual check of the blade position to determine that the switch blades are in the intended position, and then tag or padlock the operating handle in accordance with standard system operating practices. In all cases, make sure that the operating handle is locked before “walking away” from the switch.

### Warranty

The warranty and/or obligations described in Price Sheet 150, S&C’s “Standard Conditions of Sale–Immediate Purchasers in the United States” (or Price Sheet 153, “Standard Conditions of Sale–Immediate Purchasers Outside the United States”) plus any special warranty provisions, as set forth in the applicable product-line specification bulletin, are exclusive. The remedies provided in the former for breach of these warranties shall constitute the immediate purchaser’s or end user’s exclusive remedy and a fulfillment of the entire seller’s liability. In no event shall the seller’s liability to the immediate purchaser or end user exceed the price of the specific product that gives rise to the immediate purchaser’s or end user’s claim. All other warranties, whether express or implied or arising by operation of law, course of dealing, usage of trade or otherwise, are excluded. The only warranties are those stated in Price Sheet 150, (or Price Sheet 153) and THERE ARE NO EXPRESS OR IMPLIED WARRANTIES OF MERCHANTABILITY OR FITNESS FOR A PARTICULAR PURPOSE. ANY EXPRESS WARRANTY OR OTHER OBLIGATION PROVIDED IN PRICE SHEET 150 (OR PRICE SHEET 153) IS GRANTED ONLY TO THE IMMEDIATE PURCHASER AND END USER, AS DEFINED THEREIN. OTHER THAN AN END USER, NO REMOTE PURCHASER MAY RELY ON ANY AFFIRMATION OF FACT OR PROMISE THAT RELATES TO THE GOODS DESCRIBED HEREIN, ANY DESCRIPTION THAT RELATES TO THE GOODS, OR ANY REMEDIAL PROMISE INCLUDED IN PRICE SHEET 150 (OR PRICE SHEET 153.)

### Warranty Qualifications

The standard warranty is applicable to the S&C Alduti-Rupter Switch detailed in this instruction sheet except when it is power operated using a switch operator of other than S&C manufacture.

## Safety Precautions

---

### Understanding Safety-Alert Messages

Several types of safety-alert messages may appear throughout this instruction sheet and on labels and tags attached to the Alduti-Rupter Switch. Familiarize yourself with these types of messages and the importance of these various signal words:

#### **DANGER**

“DANGER” identifies the most serious and immediate hazards that will result in serious personal injury or death if instructions, including recommended precautions, are not followed.

#### **WARNING**

“WARNING” identifies hazards or unsafe practices that can result in serious personal injury or death if instructions, including recommended precautions, are not followed.

#### **CAUTION**

“CAUTION” identifies hazards or unsafe practices that can result in minor personal injury if instructions, including recommended precautions, are not followed.

#### **NOTICE**

“NOTICE” identifies important procedures or requirements that can result in product or property damage if instructions are not followed.

### Following Safety Instructions

If you do not understand any portion of this instruction sheet and need assistance, contact your nearest S&C Sales Office or S&C Authorized Distributor. Their telephone numbers are listed on S&C’s website [sandc.com](http://sandc.com), or call S&C Headquarters at (773) 338-1000; in Canada, call S&C Electric Canada Ltd. at (416) 249-9171.

#### **NOTICE**

Read this instruction sheet thoroughly and carefully before installing or operating your S&C Alduti-Rupter Switch.



### Replacement Instructions and Labels

If you need additional copies of this instruction sheet, contact your nearest S&C Sales Office, S&C Authorized Distributor, S&C Headquarters, or S&C Electric Canada Ltd.

It is important that any missing, damaged, or faded labels on the equipment be replaced immediately. Replacement labels are available by contacting your nearest S&C Sales Office, S&C Authorized Distributor, S&C Headquarters, or S&C Electric Canada Ltd.

Location of Safety Labels

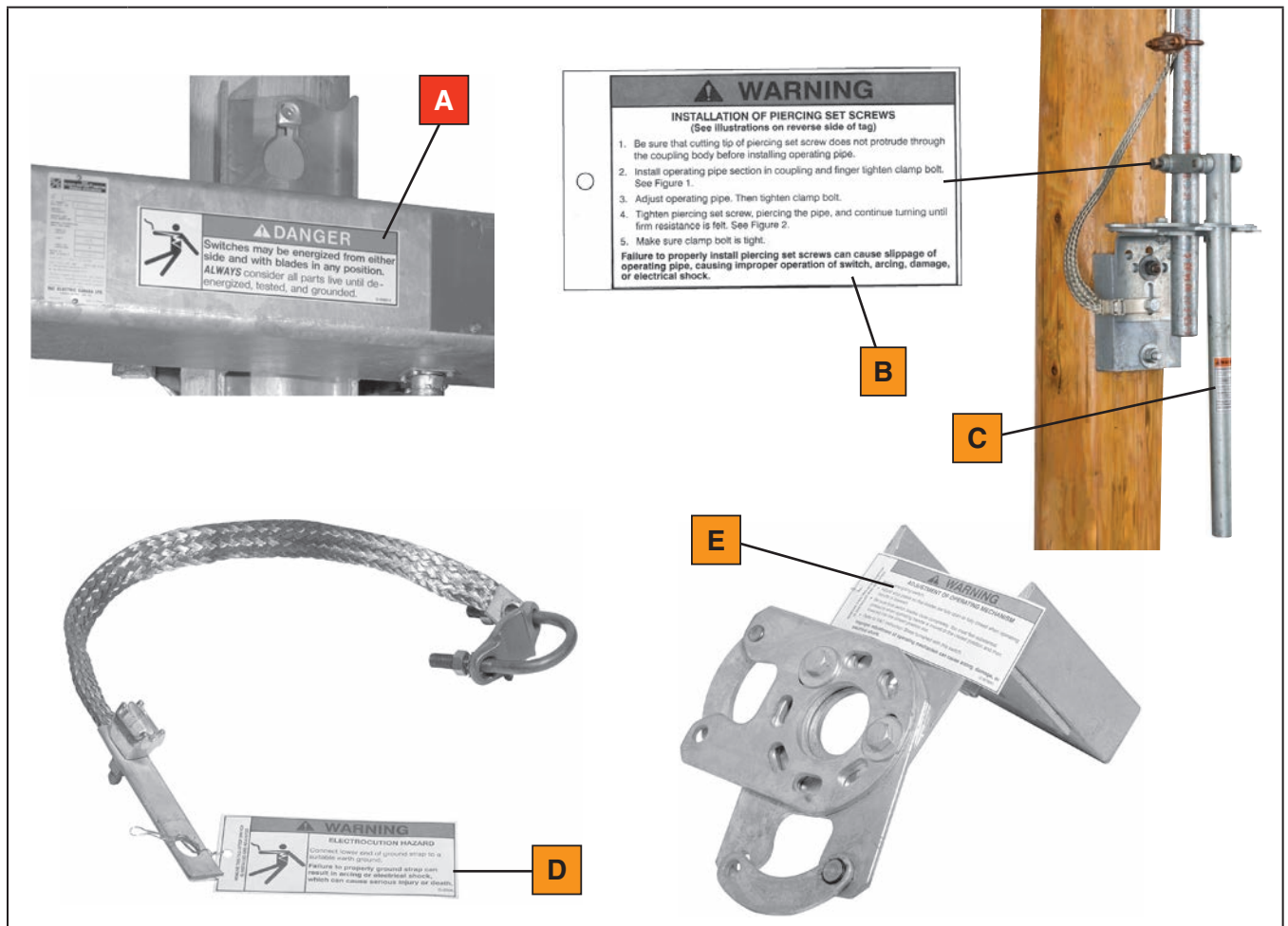

Reorder Information for Safety Labels

Location	Safety Alert Message	Description	Number
A	<b>⚠ DANGER</b>	Electrocution Hazard	G-6580-1
B	<b>⚠ WARNING</b>	Piercing Set Screws	G-10200▲
C	<b>⚠ WARNING</b>	Handle Operation	G-4400R5
D	<b>⚠ WARNING</b>	Electrocution Hazard—Grounding Strap	G-6596▲
E	<b>⚠ WARNING</b>	Adjustment of Operating Mechanism	G-3578R1▲

▲ This part is a tag that is to be removed and discarded after the switch is installed and adjusted.

## Safety Precautions

---

### DANGER



**Alduti-Rupter Switches operate at high voltage. Failure to observe these precautions will result in serious personal injury or death.**

Some of these precautions may differ from company operating procedures and rules. Where a discrepancy exists, users should follow their company's operating procedures and rules.

- 1. QUALIFIED PERSONS.** Access to switches and controls must be restricted only to qualified persons. See the "Qualified Persons" section on page 2.
- 2. SAFETY PROCEDURES.** Always follow safe operating procedures and rules.
- 3. PERSONAL PROTECTIVE EQUIPMENT.** Always use suitable protective equipment, such as rubber gloves, rubber mats, hard hats, safety glasses, and flash clothing, in accordance with safe operating procedures and rules.
- 4. SAFETY LABELS AND TAGS.** Do not remove or obscure any of the "DANGER," "WARNING," "CAUTION," or "NOTICE" labels and tags. Remove tags ONLY if instructed to do so.
- 5. ENERGIZED COMPONENTS.** Always consider all parts live until de-energized, tested, and grounded.
- 6. INTERRUPTER SWITCH POSITION.** Always confirm the **Open/Close** position of interrupter switches by visually observing the position of the blades. Switches may be energized from either side and with the blades in any position.
- 7. MAINTAINING PROPER CLEARANCE.** Always maintain proper clearance from energized components.
- 8. OPERATION.** Circuit making and breaking is involved in the normal operation of this interrupter switch and, as a result, "partway" opening or closing is undesirable. To operate, swing the operating handle through its full travel vigorously and without hesitation. See the "Operation" section on page 31.

## Shipping and Handling

---

### Inspection

Examine the shipment for external evidence of damage as soon after receipt as possible, preferably before removal from the carrier's conveyance. Check the bill of lading to make sure that shipping skids, crates, and containers listed thereon are present. If there is visible loss and/or damage:

- Notify the delivering carrier immediately.
  - Ask for a carrier inspection.
  - Note condition of shipment on all copies of the delivery receipt.
  - File a claim with the carrier.
- If concealed damage is discovered:
- Notify the delivering carrier within 15 days of receipt of shipment.
  - Ask for a carrier inspection.
  - File a claim with the carrier.
  - Also notify S&C Electric Company in all instances of loss and/or damage.

## Packing

### Standard Mounting Arrangements

Study the erection drawing carefully and check the bill of materials to make sure all of the parts are at hand. When a standard mounting arrangement is specified, the shipment includes:

- A three-pole interrupter switch, complete with interphase drive, factory assembled on a single base (All switch adjustments, including that of the interphase drive, are made at the factory to ensure proper operation and simultaneity of opening and closing.)
- Three vertical operating-pipe sections—one pipe section for pedestal mounting configuration switches (Switch may be furnished “less operating pipe,” if specified.)
- Operating mechanism components, such as handle, guide bearings, and couplings—each tagged and keyed to the bill of materials for ready identification

### Standard Minor Modifications

The erection drawing (ED) also indicates the standard minor modifications available for the standard mounting arrangement. The components included with these modifications are shown on the erection drawing bill of material under the specified “-SX” suffix. They include:

-S2: Cypoxy™ Insulator unit in a vertical operating shaft

-S6: Key interlock—single lock for “locked-open” application

-S6L: Provision for key interlock—allows future addition of single lock for “locked-open” application

-S7 Auxiliary contact switch with 4 N/O and 4 N/C contacts (600 Vac, 20 A)

-S8: Provision for power operation of pole-mounted switches by S&C Switch Operator—Type AS-1A

-S9: Provision for power operation of pedestal-mounted switches by S&C Switch Operator—Type AS-1A

-S16: Provision for power operation of pole-mounted switches by S&C 6801M Automatic Switch Operator

Drawing RD-10002, detailing the various modifications, is included in addition to the erection drawing.

### Power Operation

If suffix “-S8” or “-S9” is specified, S&C Instruction Sheets 769-500 and 769-501, “S&C Switch Operators—Type AS-1A,” are included with the switch operator shipment. Instruction Sheets 769-500 and 769-501 cover installation, operation, and adjustment of the switch operator and should be used in conjunction with this instruction sheet where applicable. If suffix “-S16” is specified, associated

S&C instruction sheets for the 6801M Automatic Switch Operator are included with the switch operator shipment and should be used in conjunction with this instruction sheet where applicable.

### Handling

The crate the switch is packed in is designed to be moved and lifted using a lift truck. Raised slots in the bottom of the crate are provided for a lift truck’s forks.

#### NOTICE

To minimize time-consuming final adjustments after installation, make sure the switch poles are in their fully **Closed** position and their toggle mechanisms are against their closed stops during installation of the vertical operating-pipe sections. Switch blades can be tied to their jaw-contact members, and the toggle mechanisms can be tied to their stops.

#### ⚠ WARNING

DO NOT lift the switch by rigging on the “live parts” or subject these parts to undue stress from slings or fall lines.

Lifting the switch by the live parts will damage the switch. Rough handling may cause damage to the blades, contacts, and/or interrupters.

Failure to lift the switch properly can result in switch damage, causing improper operation, arcing, or electrical shock.

## Preparing the Wood Pole

### Pole-Top Mounting Configuration Switch

**STEP 1.** Drill two  $\frac{13}{16}$ -inch diameter holes through the utility pole for attachment of the pole-top switch-mounting bracket. See Figure 2. Refer to the erection drawing.

For optimum support, the bracket should be positioned so it is in contact with the top surface of the utility pole.

**STEP 2.** Insert a  $\frac{3}{4}$ -inch diameter through-bolt (not furnished) into each hole as shown in Figure 3.

*Loosely* attach a square washer behind the spring (when mounting to a wood utility pole—see the *Notice* on this page), and nut on each bolt.

#### NOTICE

When mounting to a wood utility pole, a Belleville washer must be used between the square washer and the nut to maintain fastener tightness in the event of wood shrinkage. See Figure 4.

Proceed to Step 5 on page 10.

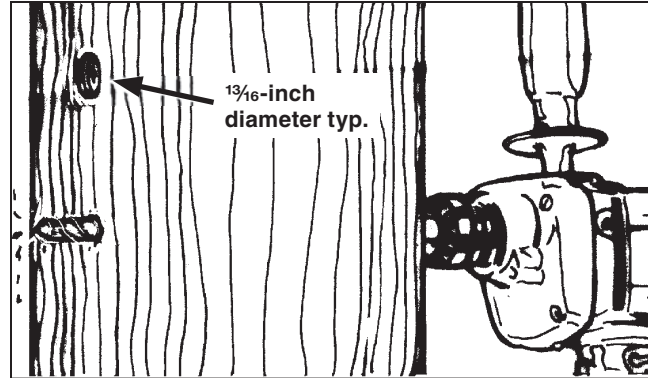

Figure 2. Drill holes for switch-mounting bracket.

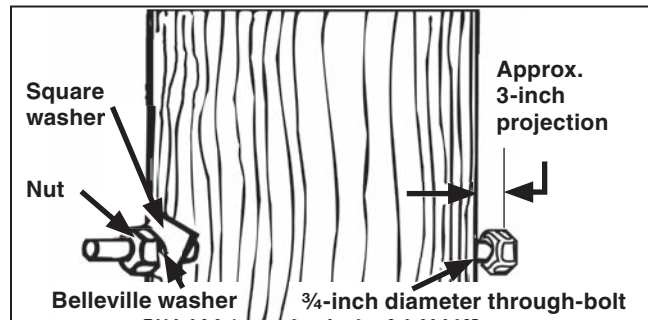

Figure 3. Install the through-bolts. Use a square washer against the wood pole and a Belleville washer between the square washer and the nut.

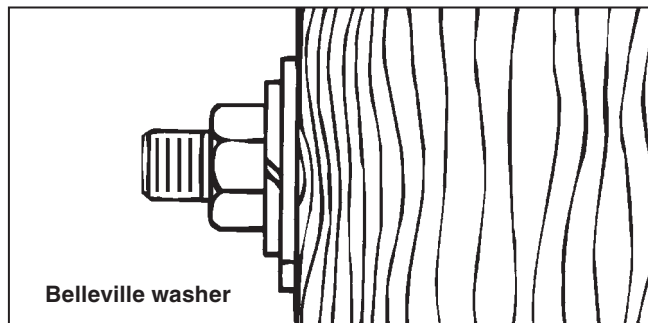

Figure 4. Use a Belleville washer between the nut and the square washer.

### Upright Mounting Configuration Switch

**STEP 3.** Drill two  $\frac{13}{16}$ -inch diameter holes through the utility pole as shown and at the desired height for mounting the switch. See Figure 5. Refer to the erection drawing.

**STEP 4.** Insert a  $\frac{3}{4}$ -inch diameter through-bolt (not furnished) into each hole as shown in Figure 6.

*Loosely* attach a square washer behind the spring (when mounting to a wood utility pole—see the *Notice* on this page) and nut on each bolt.

#### NOTICE

When mounting to a wood utility pole, a Belleville washer must be used between the square washer and the nut to maintain fastener tightness in the event of wood shrinkage. See Figure 7.

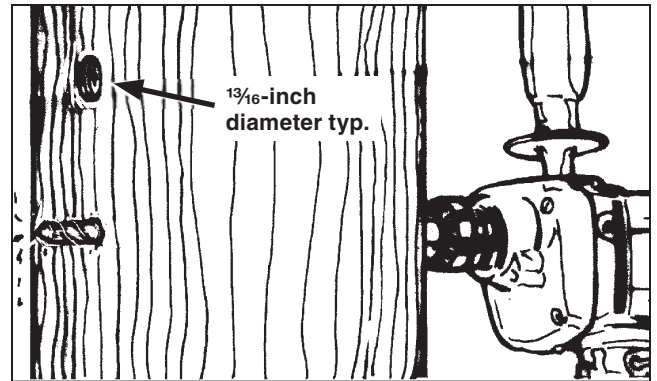

Figure 5. Drill holes for switch-mounting bracket.

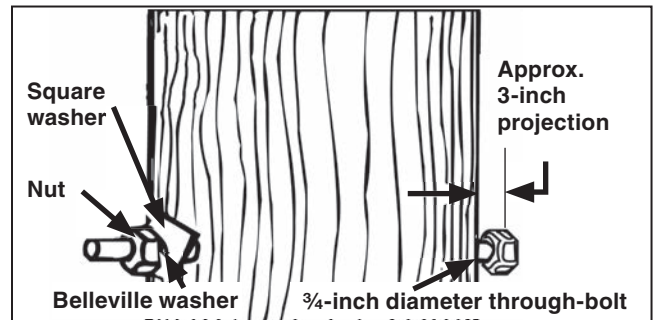

Figure 6. Install the through bolts. Use a square washer against the wood pole and a Belleville washer between the square washer and nut.

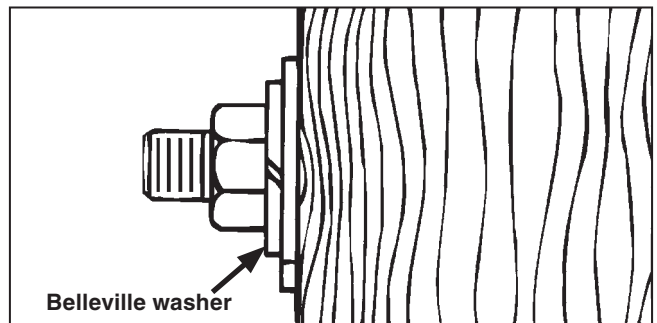

Figure 7. Install a Belleville washer between the nut and square washer.

# Installation

## Uncrating the Switch

**STEP 5.** Remove the switch from its crate. See Figure 8. Protect the bearings at the base of each pole unit from contamination by dirt, mud, oil, etc. If necessary, use blocks to keep the bottom of the switch clear of the ground.

For pole-top mounting configuration switches, proceed to Step 6.

For upright mounting configuration switches, proceed to Step 12 on page 13.

For pedestal mounting configuration switches, proceed to Step 19 on page 15.

## Lifting Pole-Top Mounting Configuration Switch

**STEP 6.** To minimize time-consuming final adjustments, make sure the switch is fully closed. Tie the switch blades to their stationary main contact assemblies using a wire tie. See Figure 9.

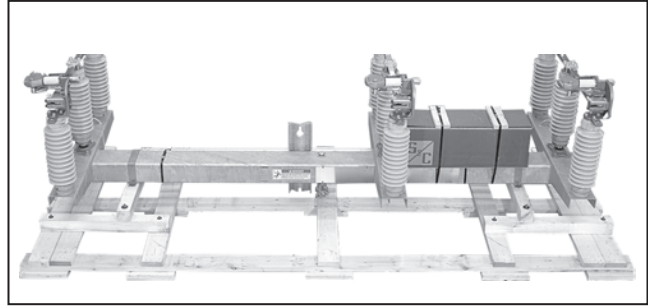

Figure 8. Remove the switch from its crate.

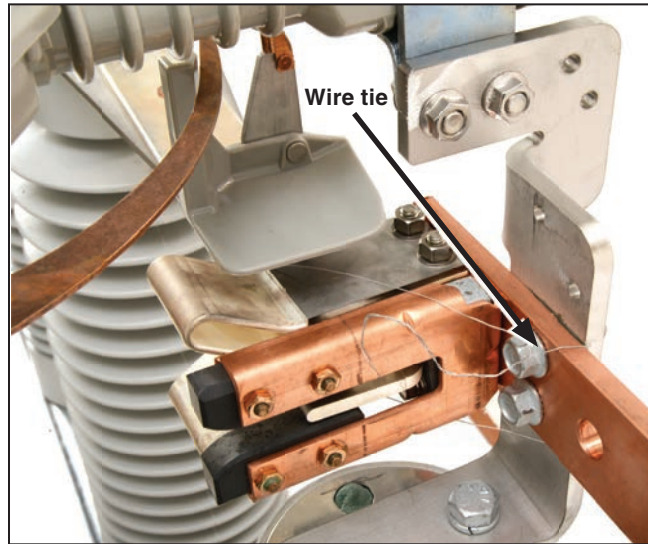

Figure 9. Tie the switch blade to the main contacts.

**STEP 7.** Hoist and guide the switch-mounting bracket so the through-bolt heads enter into the keyhole and open slotted hole in the bracket. See Figure 10.

**STEP 8.** Fully tighten the bolts. See Figure 11. Afterward, remove the lifting slings.

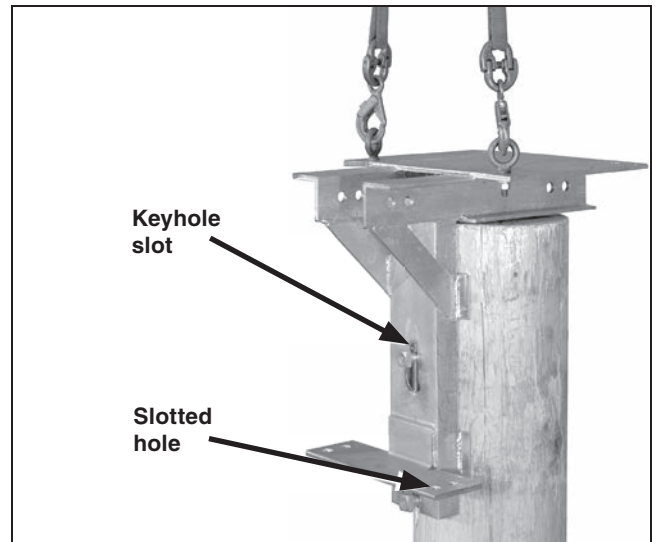

Figure 10. Hoist switch-mounting bracket.

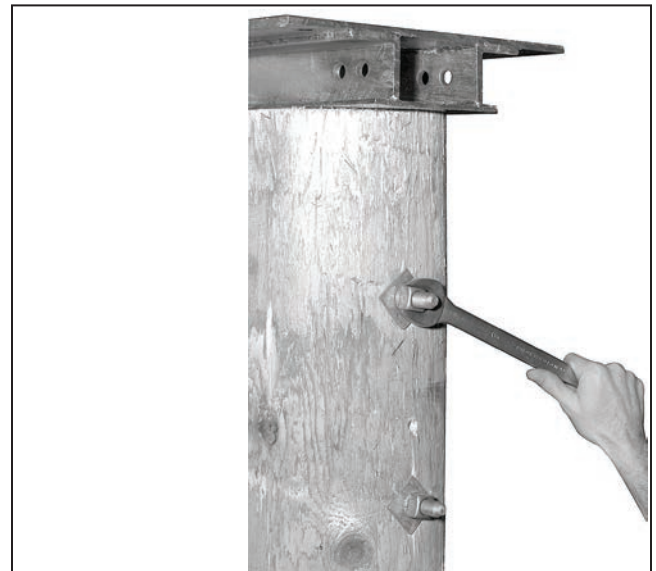

Figure 11. Tighten through-bolts.

## Installation

**STEP 9.** Attach the pole band to the switch-mounting bracket using the J-bolts furnished. Use a stiffening block under each nut. See Figure 12.

Use a  $\frac{5}{8}$ -inch diameter lag bolt (not furnished) to secure the pole band to the utility pole.

**STEP 10.**

### NOTICE

**Do not** lift the switch by rigging to the “live parts” or subject these parts to undue stress from slings or fall lines. Misalignment of the contacts and the interrupters may result from improper handling.

Hoist the switch using the four lifting eyes attached to the outboard switch pole-unit bases. See Figure 13.

**STEP 11.** Bolt the switch to the switch-mounting bracket using four  $\frac{5}{8}$ -11 $\times$ 1 $\frac{3}{4}$ -inch galvanized steel cap screws, flat washers, lockwashers, and nuts furnished. See Figure 14.

Securely tighten the hardware.

Proceed to the “Installing Pipe Couplings with Piercing Set Screws” section on page 16.

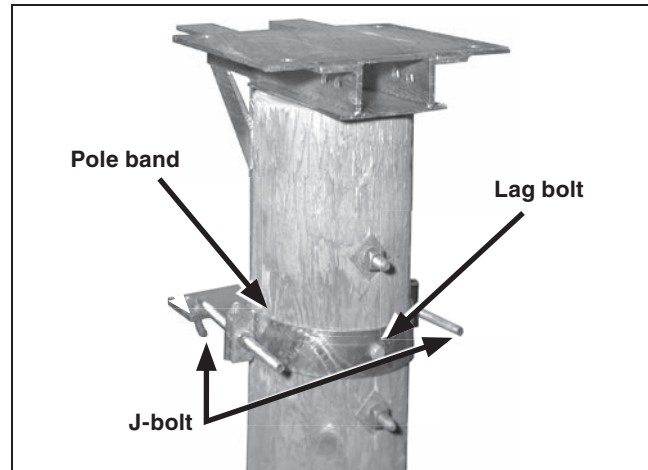

Figure 12. Attach pole band.

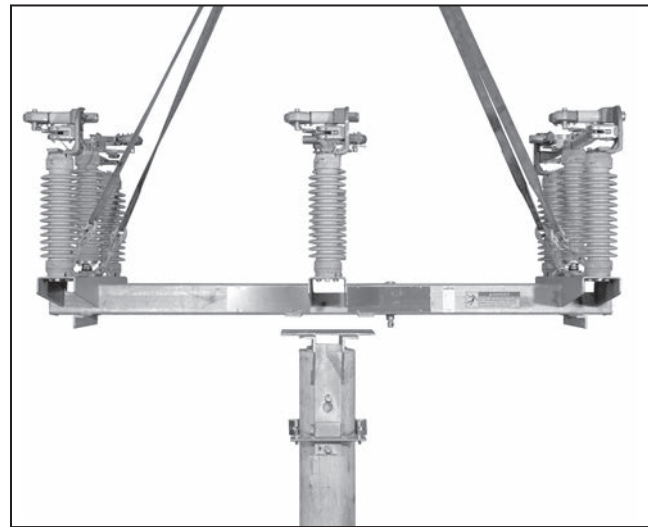

Figure 13. Hoist switch into position.

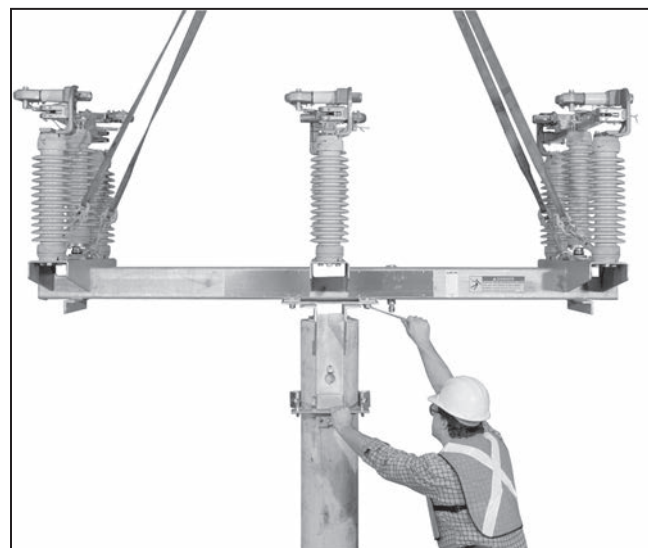

Figure 14. Bolt switch to switch-mounting bracket.

### Lifting Upright Mounting Configuration Switch

**STEP 12.** To minimize time-consuming final adjustments, make sure the switch is fully closed. Tie the switch blades to their stationary main contact assemblies using a wire tie. See Figure 15.

**STEP 13.**

**⚠ WARNING**

DO NOT lift the switch by rigging on the “live parts” or subject these parts to undue stress from slings or fall lines.

Lifting the switch by the live parts will damage the switch. Rough handling may cause damage to the blades, contacts, and/or interrupters.

Failure to lift the switch properly can result in switch damage, causing improper operation, arcing, or electrical shock.

Hoist the switch using the four lifting eyes attached to the outboard switch pole-unit bases. See Figure 16.

**STEP 14.** Guide the switch so the through-bolt heads enter into the keyhole slot and open slotted hole in the switch base. See Figure 17.

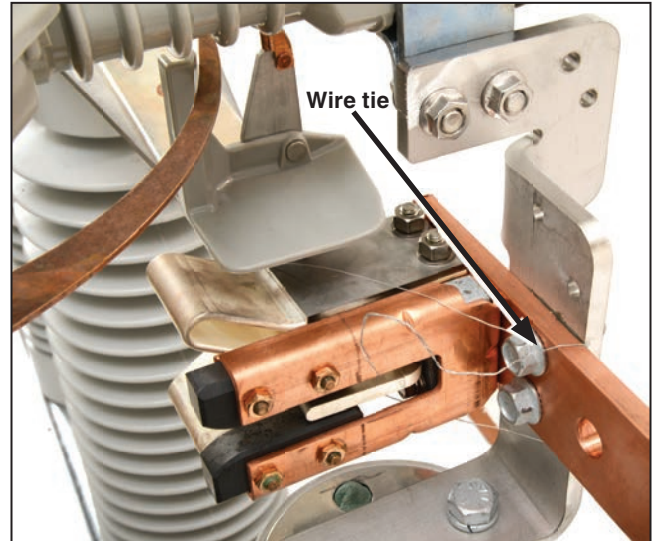

Figure 15. Tie the switch blade to the main contacts.

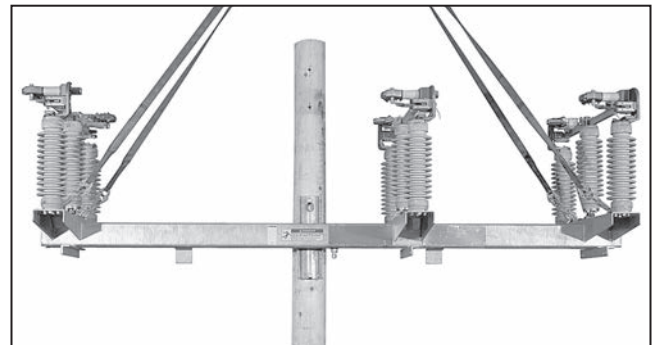

Figure 16. Hoist the switch into position.

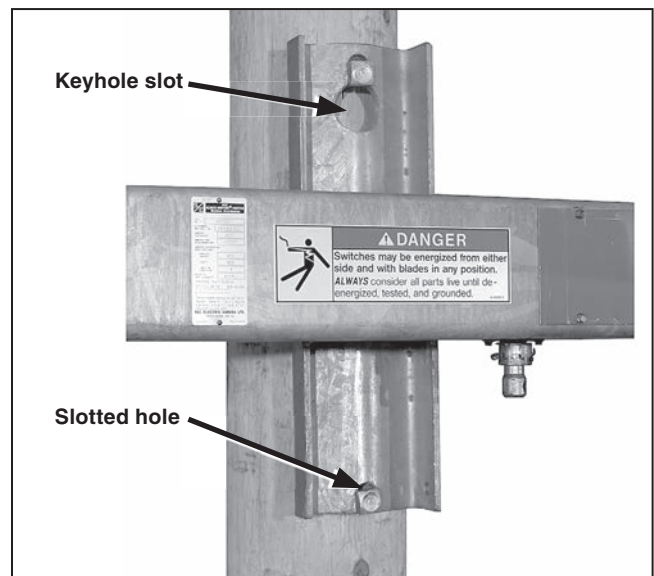

Figure 17. Guide the switch.

## Installation

**STEP 15.** *Slowly* lower the switch until it just bears on the through-bolts. Fully tighten the bolts. See Figure 18. Afterward, remove the lifting slings.

**STEP 16.** Attach the pole bands to the switch base anchor brackets using the J-bolts furnished. Use a stiffening block under each nut. See Figure 19.

Use  $\frac{5}{8}$ -inch diameter lag bolts (not furnished) to secure the pole bands to the utility pole.

**STEP 17.** Attach the crossarm braces to the switch base using the  $\frac{1}{2}$ -13 $\times$ 2-inch galvanized steel cap screws, flat washers, lockwashers, and nuts furnished. See Figure 20.



Figure 18. Tighten the bolts.

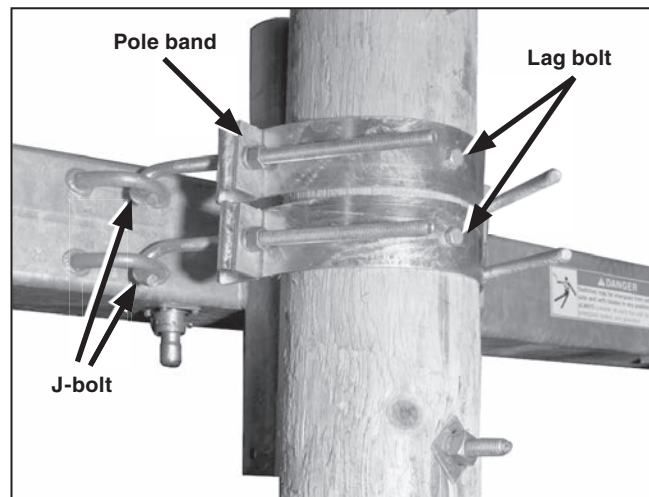

Figure 19. Attach the pole bands.

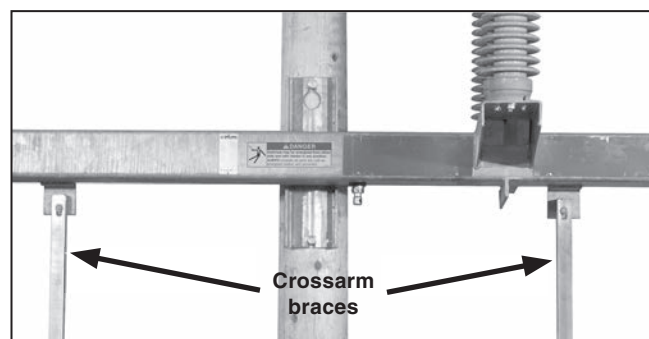

Figure 20. Attach the crossarm braces to the switch base.

**STEP 18.** Drill one  $\frac{1}{16}$ -inch diameter hole through the utility pole for attachment of the crossarm braces.

Insert a  $\frac{5}{8}$ -inch diameter through-bolt (not furnished) through the crossarm braces and hole in the utility pole. Install a square washer behind the spring (when mounting to a wood utility pole) and a nut on the bolt. Fully tighten the bolt. See Figure 21.

Proceed to the “Installing Pipe Couplings with Piercing Set Screws” section on page 16.

### Lifting Pedestal Mounting Configuration Switch

**STEP 19.** Install the mounting pedestal as indicated on the erection drawing.

To minimize time-consuming final adjustments, make sure the switch is fully closed. Tie the switch blades to their stationary main contact assemblies using a wire tie. See Figure 22.

**STEP 20.**

<b>⚠ WARNING</b>
<b>Do not</b> lift the switch by rigging to the “live parts” or subject these parts to undue stress from slings or fall lines. Misalignment of the contacts and the interrupters may result from improper handling.

Hoist the switch using the four lifting eyes attached to the outboard switch pole-unit bases. See Figure 23.

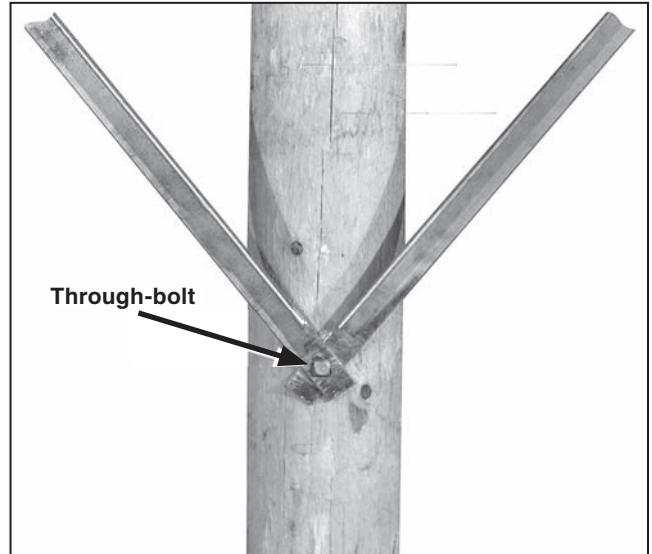

Figure 21. Bolt the crossarm braces to the utility pole.

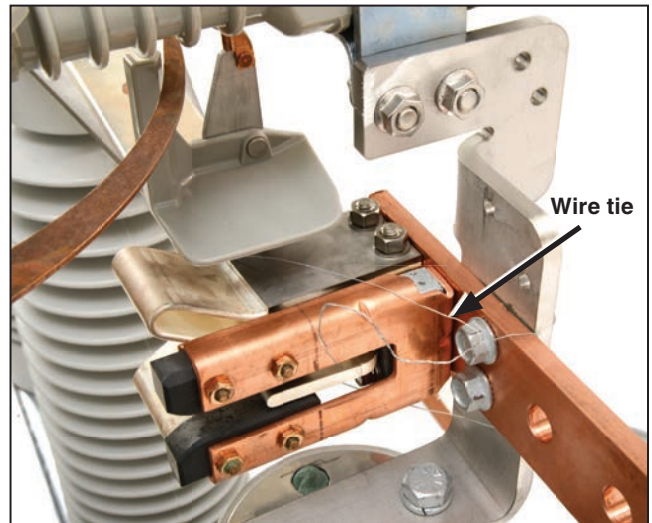

Figure 22. Tie the switch blade to the main contacts.

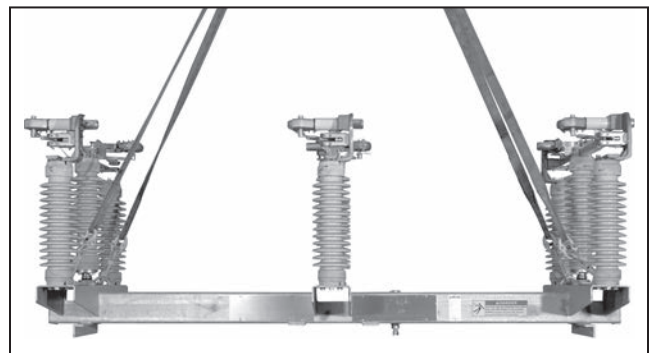

Figure 23. Hoist the switch into position.

## Installation

**STEP 21.** Bolt the switch to the mounting pedestal using four  $\frac{5}{8}$ -11 $\times$ 2 $\frac{1}{2}$ -inch galvanized steel cap screws, flat washers, lockwashers, and nuts furnished. See Figure 24.

Securely tighten the hardware.

### Installing Pipe Couplings with Piercing Set Screws

**STEP 22.**

#### **⚠ WARNING**

Failure to properly install pipe couplings with piercing set screws can cause slippage of operating pipe, resulting in improper operation of the switch, arcing, equipment damage, or electrical shock.

To properly install piercing set screws:

- Make sure the cutting tip of the piercing set screw does not protrude through the body of the clamp.
- Insert the operating pipe section into the coupling and finger-tighten the clamp bolt(s).
- Adjust the operating pipe to the correct length, and then tighten the clamp bolt(s) to final tightness.
- Tighten the piercing set screw, piercing the pipe, and continue turning until a firm resistance is felt.
- Make sure the clamp bolt(s) are tight.

See Figure 25.

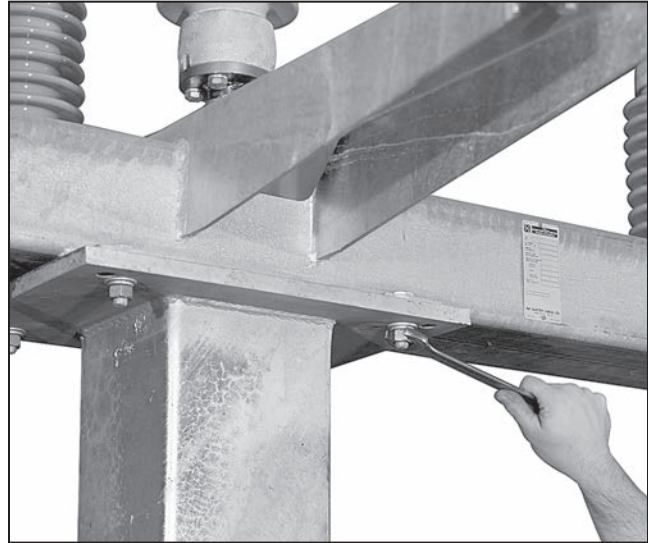

Figure 24. Bolt the switch to the mounting pedestal.

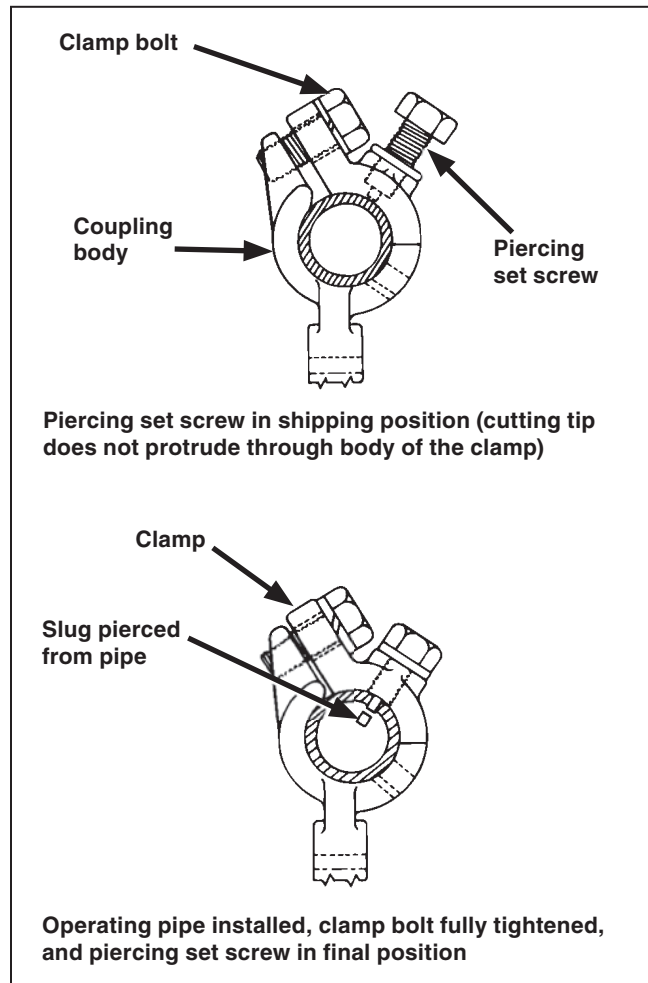

Figure 25. Install the pipe couplings. Back the piercing set screws out of the body of the coupling before installation.

## Installing the Vertical Operating Pipe

**STEP 23.** S&C recommends making each coupling connection as work progresses from the top down. Start with the universal coupling connecting the switch to the upper section of vertical operating pipe, and continue with the coupling between the upper section of vertical operating pipe and the first lower section. Continue down to the last section of pipe, and end with the rotating operating handle. This makes it easier to adjust for variations in the surface and height of the wood pole.

Attach a pipe-to-switch bearing type universal coupling to the switch drive shaft on the underside of the switch assembly with the pin and cotter pin furnished. Bend the cotter pin. See Figure 26.

**STEP 24.** Insert the uppermost section of the vertical operating pipe into the universal coupling attached to the underside of the switch assembly. See Figure 27. Back the piercing set screw out of the body of the pipe coupling clamp before tightening the bolts.

Torque the clamp bolts to final tightness, and then tighten the piercing set screw, piercing the pipe. Continue turning until a firm resistance is felt.

*For pedestal mounting configuration switches, proceed to Step 30 on page 20.*

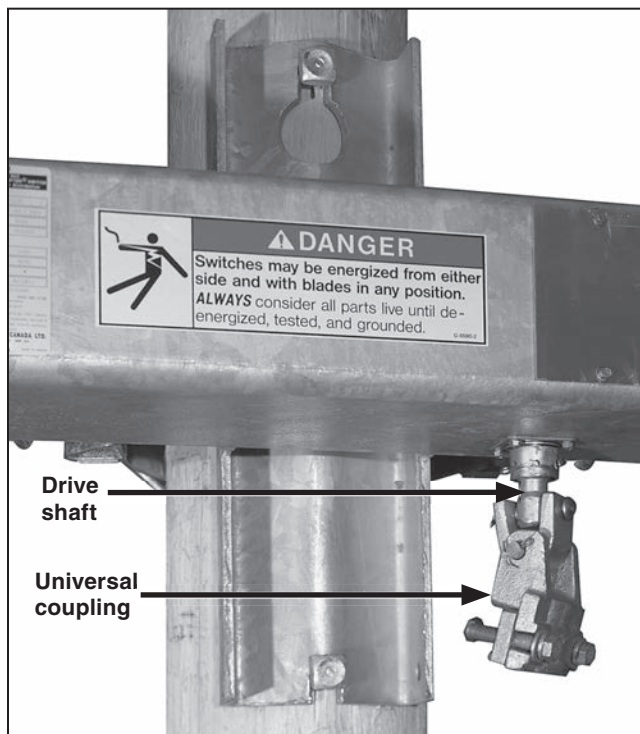

Figure 26. Attach the universal coupling to the switch drive shaft.



Figure 27. Attach the universal coupling to the switch drive shaft.

## Installation

**STEP 25.** Attach a pipe-to-pipe type universal coupling to the lower end of the uppermost section of vertical operating pipe. See Figure 28. Back the piercing set screw out of the body of the pipe coupling before tightening the coupling clamp bolts.

Torque the clamp bolts to final tightness, and then tighten the piercing set screw, piercing the pipe. Continue turning until a firm resistance is felt.

**STEP 26.** Position and install the guide bearing assembly on the pole in accordance with the dimension shown on the erection drawing. See Figure 29.

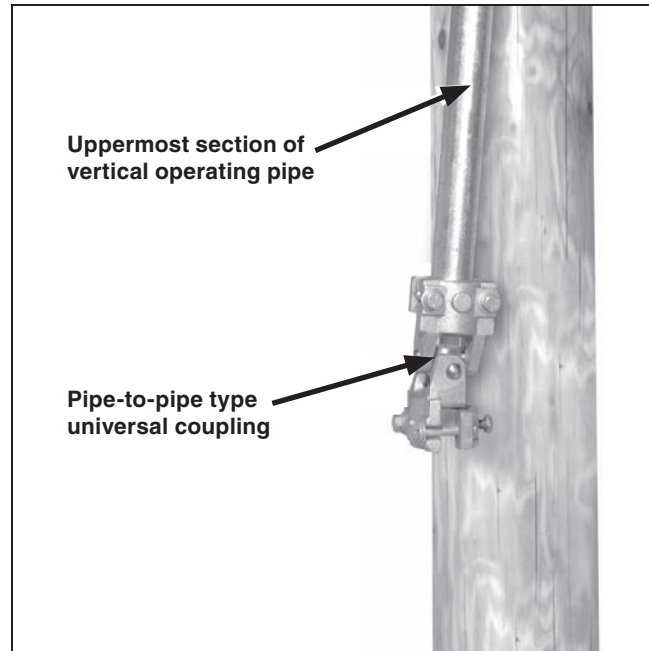

Figure 28. Attach the pipe-to-pipe type universal coupling to the lower end of the vertical operating pipe.

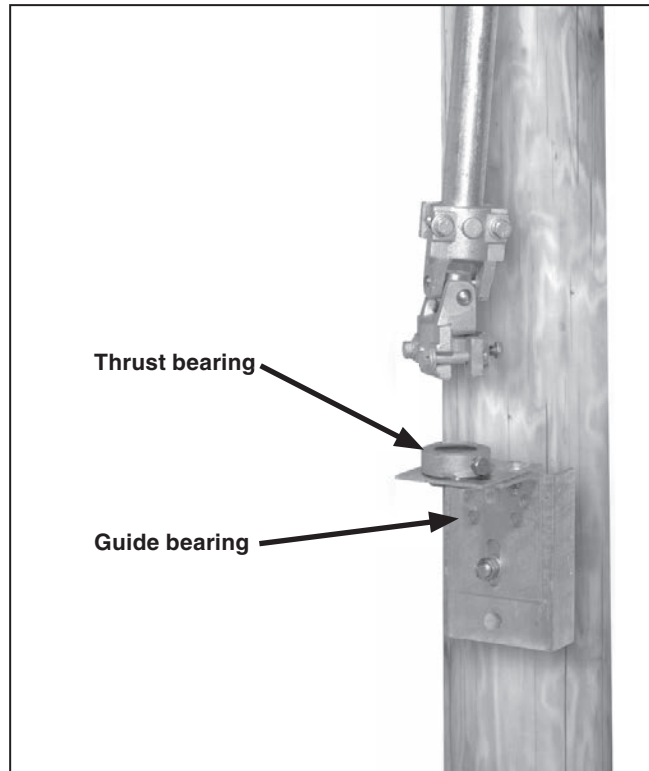

Figure 29. Install the guide bearing.

**STEP 27.** Pass the next section of the vertical operating pipe up through the guide bearing and then through the thrust bearing. The thrust bearing will rest on the guide bearing and support the operating pipe. See Figure 30.

Insert the pipe section into the universal coupling previously attached to the lower end of the uppermost operating-pipe section. *Do not tighten the coupling clamp at this time.*

While holding the pipe in this position—and with the thrust bearing resting on the guide bearing—tighten the piercing set screw in the thrust bearing, piercing the pipe. Continue turning until a firm resistance is felt.

**STEP 28.** Install a guide-bearing assembly with each additional vertical operating-pipe section, positioned in accordance with the dimension shown on the erection drawing. See Figure 31. Thrust bearings are only necessary on the uppermost guide bearing. Use rigid couplings to join these additional pipe sections. Before installing the coupling, back the piercing set screws out of the coupling body so they do not protrude into the coupling.

Torque the clamp bolts to final tightness, and then tighten the piercing set screws, piercing the pipe. Continue turning until a firm resistance is felt.

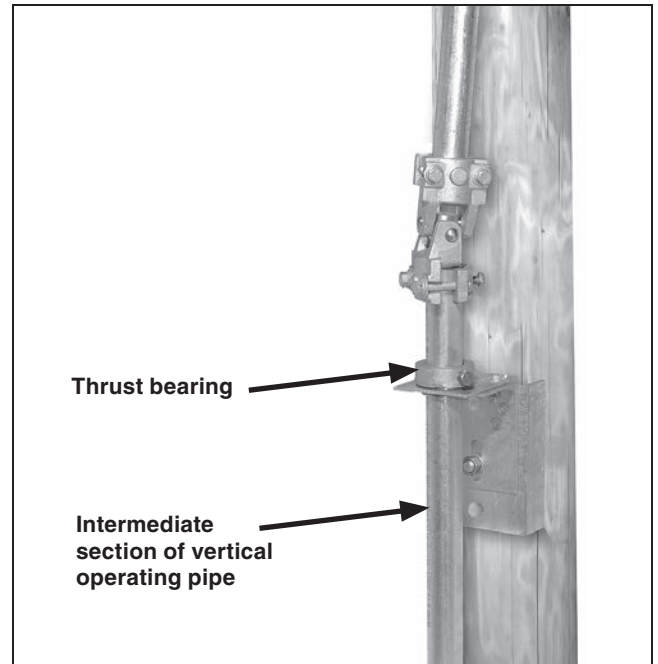

**Figure 30.** Install the intermediate section of the vertical operating pipe. Make sure the thrust bearing is resting on the guide bearing.

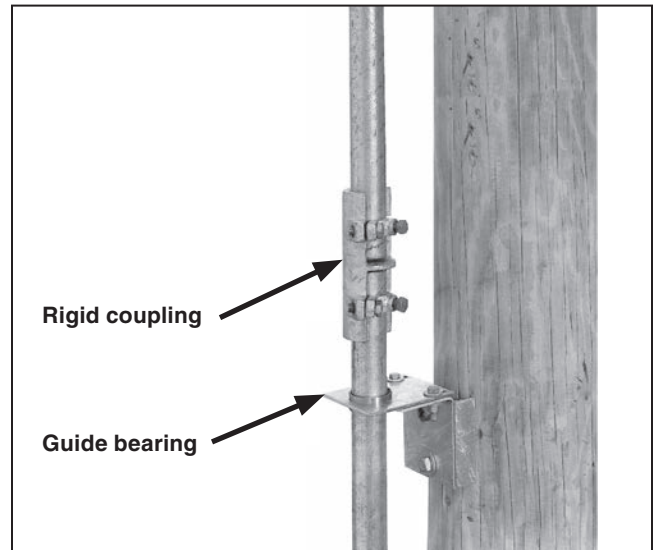

**Figure 31.** Install the guide-bearing assembly for additional pipe section.

## Installation

**STEP 29.** Tighten the piercing set screw of the rigid coupling immediately above the last section of pipe to final tightness, piercing the pipe. Continue tightening until a firm resistance is felt. ● See Figure 31.

● If the shipment includes an S&C Type AS-1A Switch Operator, as signified by the addition of the Standard Minor Modification Suffix “-S8” or “-S9” to the erection drawing number, refer instead to S&C Instruction 769-500, “S&C Switch Operators—Type AS-1A, “Instructions for Installation.” If the shipment includes an S&C 6801M Automatic Switch Operator, as signified by the addition of Standard Minor Modification suffix “-S16” to the erection drawing number, refer instead to S&C Instruction Sheet 1045M-510.

### Installing Operating Handle

**STEP 30.** When a key interlock is used (standard minor modification suffix “-S6”), skip to Step 33 on page 22.

Back the piercing set screws out of the handle yoke and slide the handle assembly up the pipe until it is in the location indicated on the erection drawing. There should be 6 to 8 inches (15 to 20 cm) of operating pipe below the operating handle assembly. See Figure 32.

Tighten one piercing set screw on the operating handle assembly enough to hold the handle in place, but DO NOT pierce the vertical operating pipe.

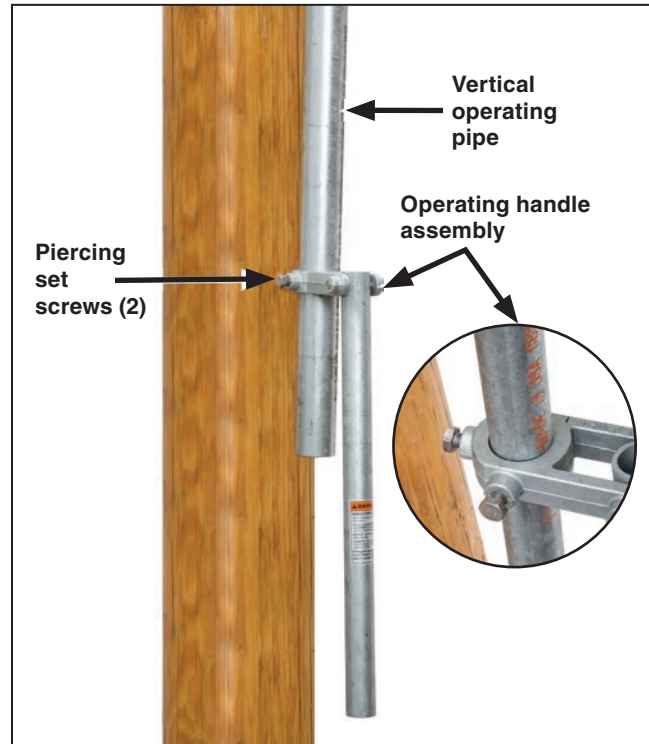

**Figure 32.** Install the operating handle assembly.

**STEP 31.** Slide the foot-bearing assembly onto the lowest section of pipe at the position shown on the erection drawing. See Figure 33. Adjust the operating handle assembly until it is 2 to 3 inches (5 to 8 cm) above the foot-bearing assembly. Tighten the piercing set screws, piercing the pipe. Continue turning until a firm resistance is felt, and then use one of the mounting bolts to attach one end of the ground strap (the end with the grounding connector attached) to the foot-bearing assembly. The grounding recommendations in this document may differ from the standard operating and safety procedures of certain electric utility companies. Where a discrepancy exists, the operating procedures of the electric utility apply.

If necessary to compensate for the taper of the wood pole and to keep the vertical operating pipe aligned and plumb, shift the guide bearings toward or away from the pole. Alignment slots are provided for this purpose.

**STEP 32.** Fasten the free end of the grounding strap to the lowest pipe section a few inches above the operating handle assembly (or key interlock) with the U-bolt connector provided for this purpose. See Figure 34. Afterward, connect the lower end of the strap to a suitable earth ground using the grounding connector provided at that end of the strap. The grounding recommendations in this document may differ from the standard operating and safety procedures of certain electric utility companies. Where a discrepancy exists, the operating procedures of the electric utility apply.

Skip to Step 38 on page 25.

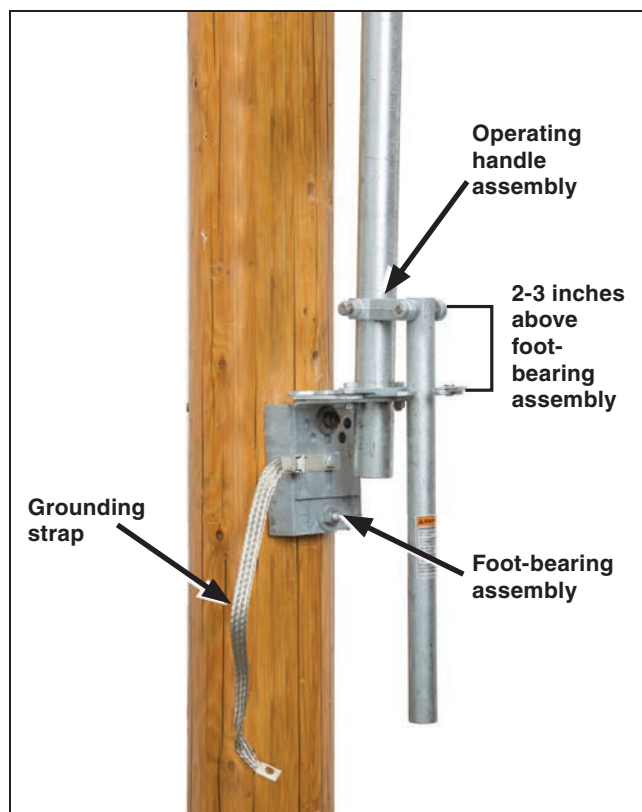

Figure 33. Attach the foot-bearing assembly.

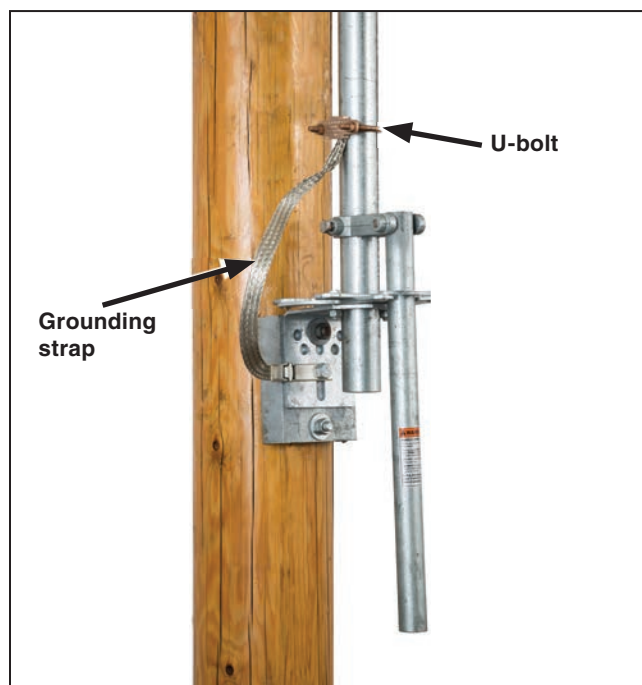

Figure 34. Attach the grounding strap.

## Installation

### Installing Operating Handle with Key Interlock

#### NOTICE

The key interlock must be installed after the operating handle is installed and the stop plates are fully adjusted.

**STEP 33.** The interlock group includes a Superior Type B6003-1 Mk II single- or multiple-key interlock (or equivalent), with  $\frac{3}{8}$ -inch bolt projection and  $\frac{3}{4}$ -inch bolt travel, locking disc, and interlock bracket. If “provision only” is specified, the interlock is not included.

Slide the interlock bracket, locking disc, operating handle assembly, and foot-bearing assembly onto the lowest vertical operating-pipe section, with the locking disc and operating handle assembly between the interlock bracket and the foot-bearing assembly. See Figure 35.

**STEP 34.** Bolt the foot-bearing assembly to the pole at the position shown on the erection drawing. Use one of the mounting bolts to attach one end of the grounding strap (the end with the grounding connector attached) to the foot-bearing assembly.

The grounding recommendations described in the document may differ from the standard operating and safety procedures of certain electric utility companies. Where a discrepancy exists, the operating procedures of the electric utility apply. See Figure 36.

If necessary to compensate for the taper of the wood pole and to keep the vertical operating pipe aligned and plumb, shift the guide bearing toward or away from the pole. Alignment slots are provided for this purpose.

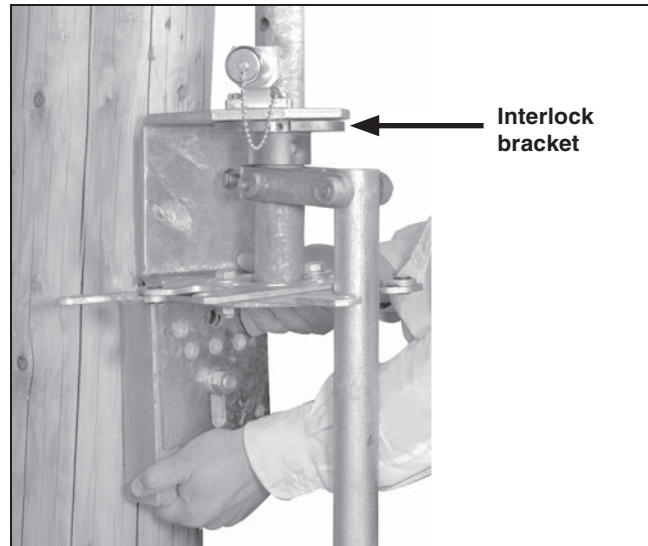

**Figure 35.** Position the interlock bracket, locking disc, operating handle assembly, and foot-bearing assembly onto lowest vertical operating-pipe section.

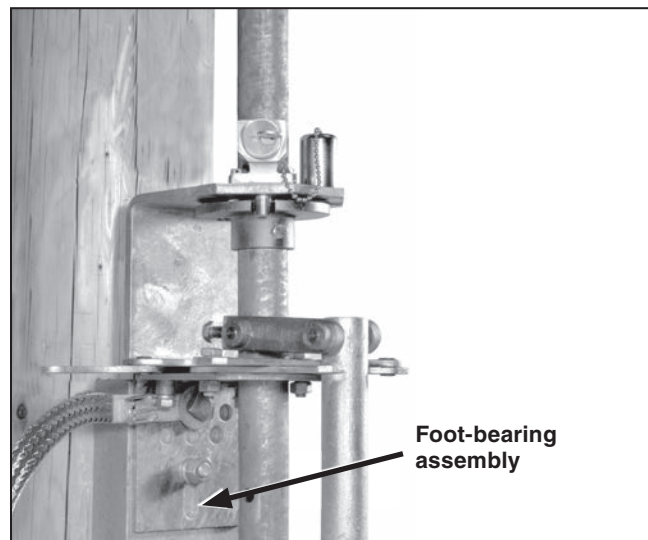

**Figure 36.** Attaching foot-bearing assembly.

**NOTICE**

Key interlocks are intended for proper sequencing of switch operations; they are not intended to provide security. The operating handle assembly includes swing-away hasps for padlocking the switch in either the Open or Closed position.

**STEP 35.** Block one of the two slots in the locking disc with the blocking screw provided. (The slot to be blocked depends on whether a locked-open or locked-closed arrangement is required.) See Figure 37.

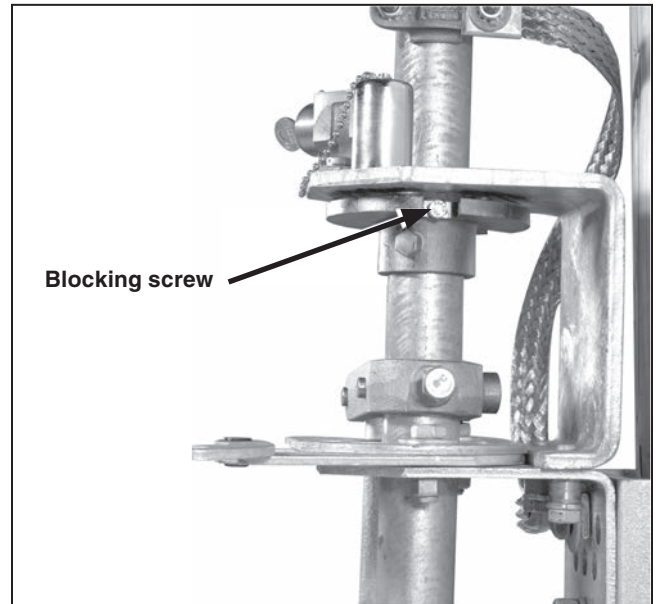

Figure 37. Blocking screw installed in the locking disc.

## Installation

**STEP 36.** Fasten the operating handle assembly to the lowest vertical operating-pipe section using the piercing set screws to secure the operating handle assembly. See Figure 38.

Tighten the piercing set screw on the operating handle assembly, piercing the pipe. Continue turning until a firm resistance is felt.

Attach the interlock bracket to the foot-bearing assembly, using the  $\frac{1}{2}$ -13  $\times$   $\frac{1}{2}$ -inch cap screws, spacers, and lockwashers furnished.

With the switch in the **Closed** position, use the interlock bolt to position the locking disc so the bolt enters the **Closed** position slot in the disc (and will enter the **Open** position slot when the switch is in the **Open** position.)

**STEP 37.** Hold the locking disc  $\frac{3}{8}$ -inch below the interlock bracket and drill  $\frac{7}{16}$ -inch diameter holes through the vertical operating-pipe section, using the holes in the locking disc collar as pilots. Attach the locking disc to the pipe using the  $\frac{3}{8}$ -16  $\times$  3-inch cap screw, lockwasher, and nut furnished. See Figure 39.

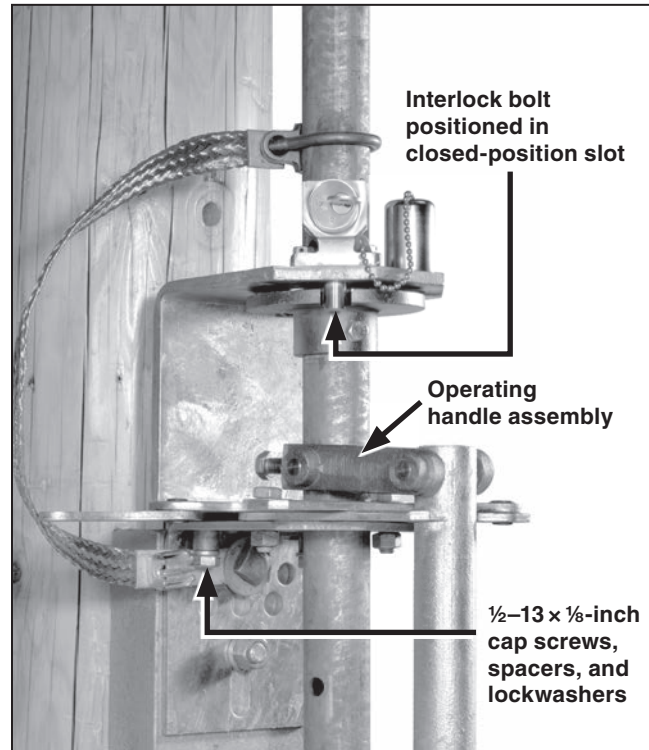

Figure 38. Fasten the operating-handle assembly.

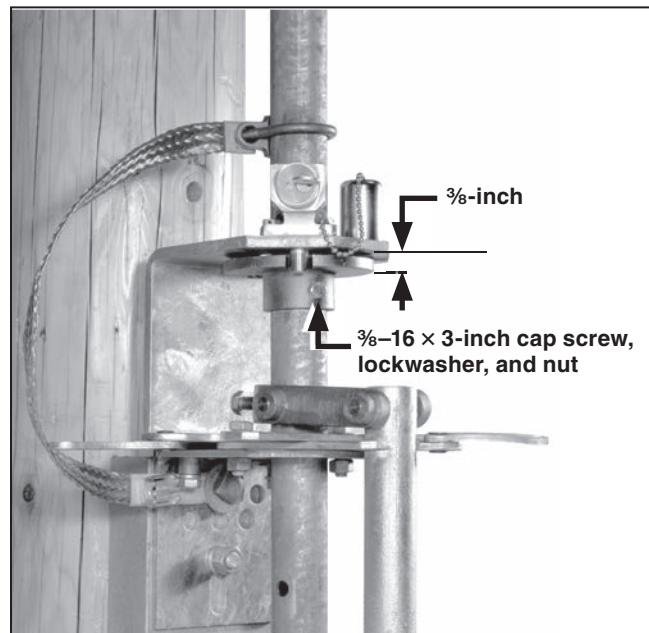

Figure 39. Attaching the locking disc.

## Checking Alignment and Adjusting the Stop Plates

**STEP 38.** Remove the ties holding the switch blades to their stationary main contact assemblies. See Figure 40.

Open and close the switch *slowly* to ensure no operational difficulties are encountered caused by undetected damage in shipping.

### ⚠ WARNING

Open and close the switch slowly **ONLY** when checking the operation or making adjustments to the de-energized switch.

When opening or closing an energized switch, swing the operating handle vigorously through its full travel without hesitation.

Arcing and damage to the switch will occur if the energized switch is operated slowly or left in the partially **Open** or **Closed** position.

**STEP 39.** The stop plate holes are slotted to allow room for adjustment. Loosen the bolts that secure the adjustable stop plates to the foot-bearing support plate. See Figure 41. Place the switch in the fully open position. Adjust the open-position stop plate so the handle, when lowered, fits into the open-position slot. Mark on the support plate the location of the open-position stop plate.

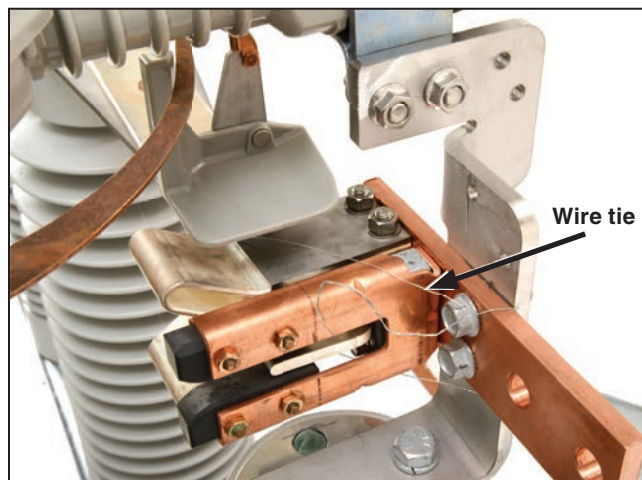

Figure 40. Remove the tie at the stationary main contact assembly.

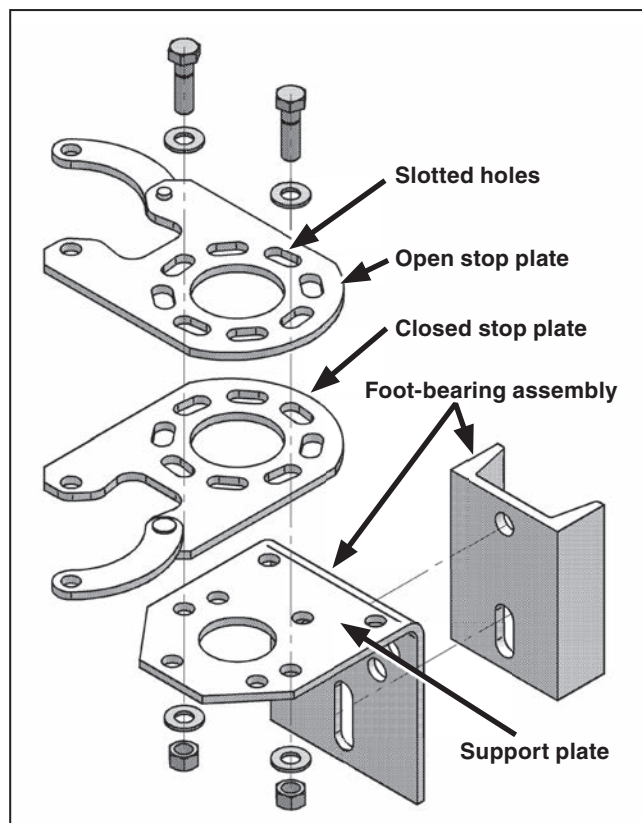

Figure 41. Stop plates and foot-bearing assembly—exploded view.

## Installation

**STEP 40.** The most common cause of contact overheating and damage is not putting enough “wind up” torque in the vertical operating pipe when the switch is in the **Closed** position. Wind up is the torque left in the pipe after the handle is secured in the closed stop plate. This windup prevents the pipe from vibrating in high winds and creates strong positive blade-to-contact pressure, ensuring the switch is securely held in the **Closed** position.

### NOTICE

**DO NOT skip this important step!** Loose or improperly installed vertical operating pipe is the primary cause of incomplete blade contact. Over time this condition can cause heating and eventually arcing of the blade contacts.

To adjust the closed stop plate:

- Loosen the hardware securing the closed stop plate. See Figure 41 on page 25.
- The stop-plate holes are slotted to allow room for adjustment. Position the operating handle in the stop plate and turn the operating handle as far as it will go in the **Closed** position. (Counterclockwise is standard on switches using the rotating operating mechanism.) The handle should be tight against the edge of the stop plate as shown in Figure 42. Mark the position of the closed stop plate. See Figure 43 (Left).
- Lift the handle out of the way and rotate the stop plate an additional 15 degrees counterclockwise from the mark. Make sure the open stop plate lines up with the open stop plate mark made in Step 39. Tighten the stop plate hardware to 40 ft-lbs. See Figure 41 on page 25.
- Push the handle into the **Closed** stop position. It should take significant force to secure the handle into the closed stop. The handle will be firmly pressed against the left side of the closed stop plate. This pressure will hold the torque in the pipe, creating the desired windup. Move the handle into the **Open** position to verify it fits into the open stop plate. See Figure 44.

**STEP 41.** Recheck to make sure all clamp bolts and piercing set screws have been torqued to final tightness.

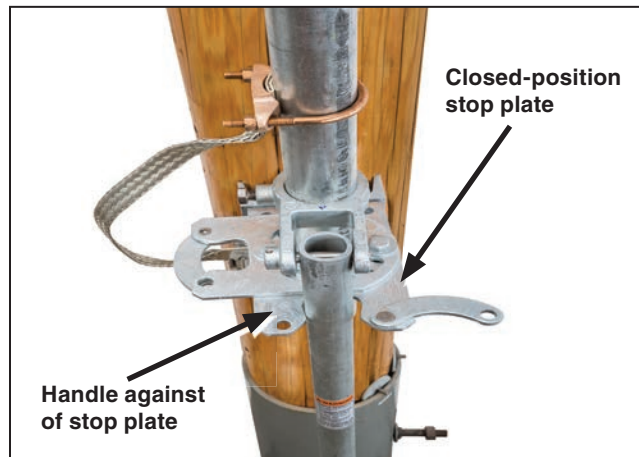

Figure 42. Adjust the closed-position stop plate.



Figure 43. Torque bolts securing the stop plates to the support plate.



Figure 44. Verify the handle fits into the open stop plate.

## Checking Operation

### ⚠ WARNING

Open and close the switch slowly **ONLY** when checking the operation or making adjustments to the de-energized switch.

When opening or closing an energized switch, swing the operating handle vigorously through its full travel without hesitation.

Arcing and damage to the switch will occur if the energized switch is operated slowly or left in the partially **Open** or **Closed** position.

**STEP 42.** Open and close the switch *slowly* through its full travel. Check to make sure the following conditions exist:

- (a) With the operating handle as far as it will go in the opening direction, the switch blades are 90 degrees from the **Closed** position (perpendicular to the channel base). See Figure 45.
- (b) With the operating handle as far as it will go in the closing direction, the blade of each switch pole is fully closed and is within  $\frac{1}{8}$ -inch of the stop on both stationary contact assemblies. See Figure 46.

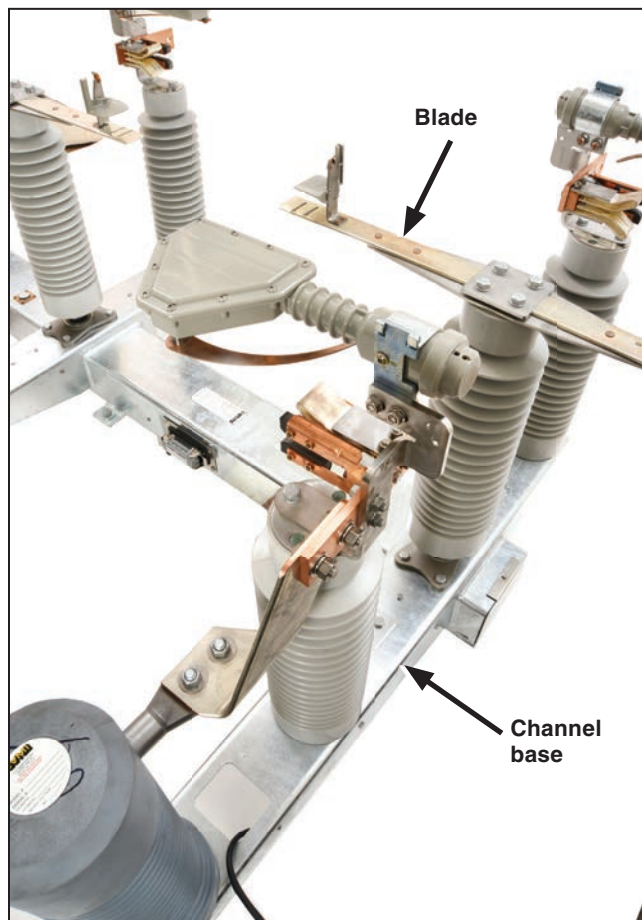

Figure 45. The blade at 90 degrees from the channel-base position.

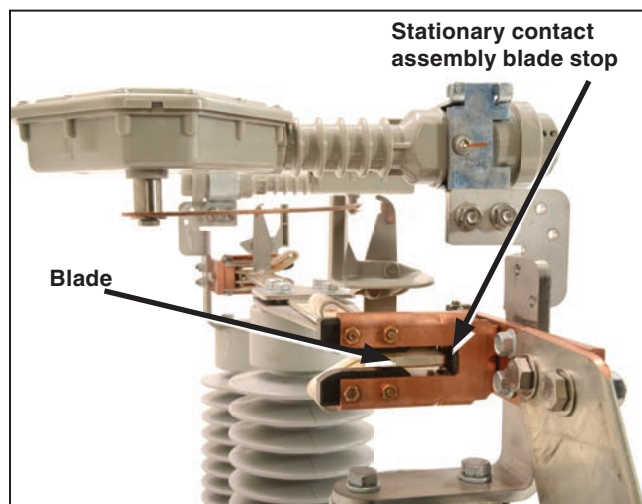

Figure 46. Check that the blade is fully closed and within  $\frac{1}{8}$ -inch of the stop on the stationary contact assembly.

## Installation

**STEP 43.** Check the following on each phase:

### NOTICE

Open and close the switch slowly **ONLY** when checking the operation or making adjustments to the de-energized switch.

When opening or closing an energized switch, swing the operating handle vigorously through its full travel without hesitation.

Arcing and damage to the switch will occur if the energized switch is operated slowly or left in the partially **Open** or **Closed** position.

- (a) Open and close the switch and examine the interrupter and blade alignment. The interrupter and interrupter shunt arm must be parallel to the sweep of the blade. See Figure 47.
- (b) Slowly open the switch. The following conditions should be met:

As the blade moves toward the open position, the operating cam shunt contacts should engage the interrupter shunt arms on the copper-bronze contact surfaces of each shunt contact. See Figure 48.

As the blades move in the opening direction the interrupters on each switch pole should actuate within  $\frac{1}{4}$ -inch blade travel.

As the blade reaches its full travel the interrupter shunt arms will be released and will quickly snap back to their closed positions and reset for the next operation. See Figure 47.

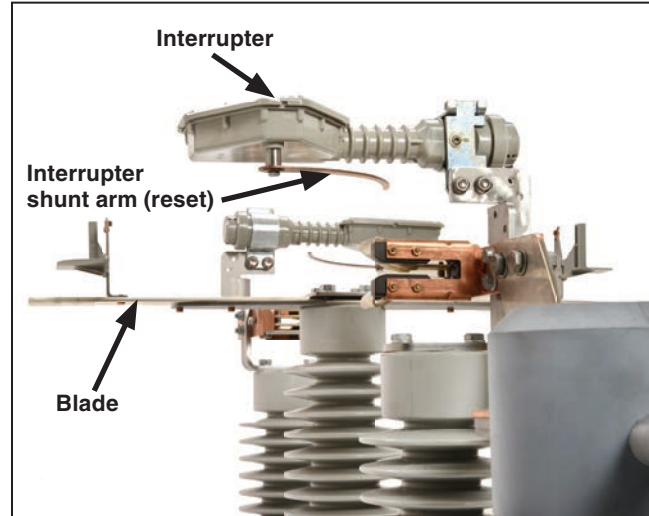

Figure 47. Make sure the interrupter and interrupter shunt arm is parallel to the sweep of the blade.

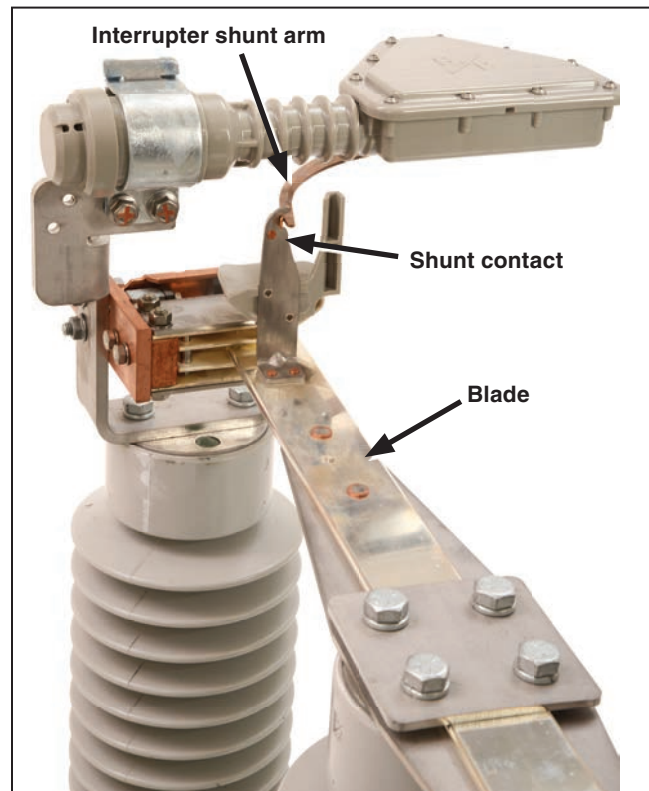

Figure 48. The shunt contacts should engage each interrupter shunt arm on the copper-bronze contact surface of each shunt contact.

- (c) Slowly close the switch. The following conditions should be met:

The interrupter shunt arms should be guided into position by the curved backs of the shunt contacts. See Figure 49.

The blades should move into each stationary contact assembly on center. See Figure 50.

When the switch is fully closed, the interrupter shunt arms are resting against or are no more than  $\frac{1}{8}$ -inch away from the auxiliary return arm of the multipurpose operating cam. See Figure 51.

If any of the conditions described in this step cannot be achieved, contact the nearest S&C Sales Office because it is likely damage was sustained during shipment.

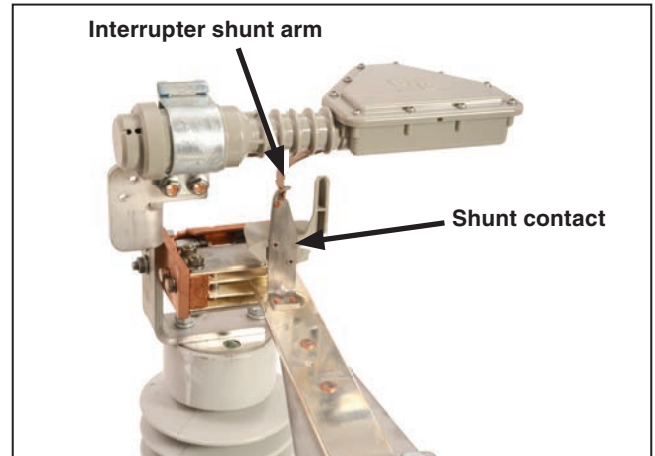

Figure 49. The shunt contacts guide each interrupter shunt arm into position.

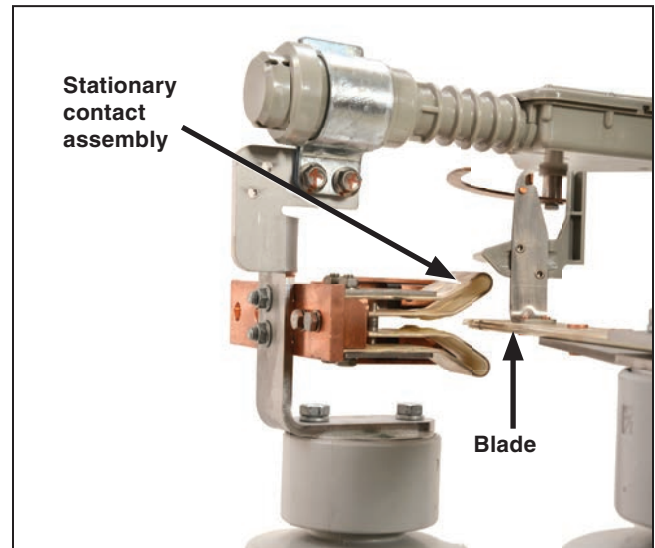

Figure 50. During closing, make sure the blade enters the stationary contact assembly on center.

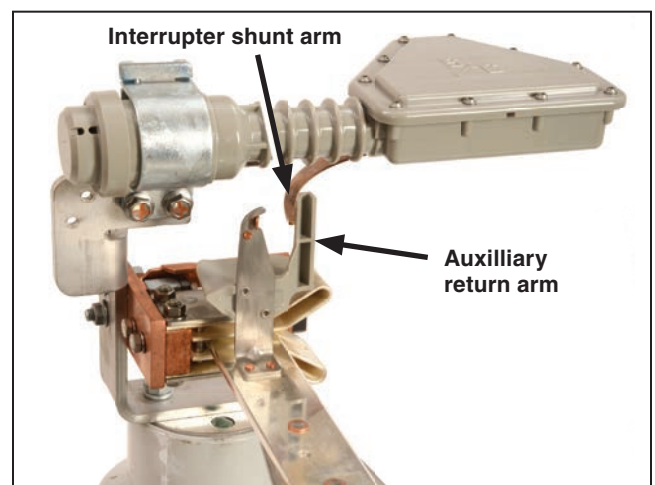

Figure 51. The interrupter shunt arm should be resting against or no more than  $\frac{1}{8}$ -inch (3.2 mm) away from the auxilliary return arm.

### Connecting High-Voltage Conductors

When high-voltage conductors are to be connected using aluminum-alloy body connectors●, use the following procedure:

#### STEP 44.

- (a) Thoroughly wire-brush the current-transfer surfaces of each connector and immediately apply a liberal coating of Penetrox® A (available from Burndy Corporation) to the brushed surfaces.
- (b) Wire-brush each terminal pad of the switch and apply a coating of Penetrox A. Afterward, bolt the connectors to the terminal pads.
- (c) Prepare the conductors using established procedures, and clamp them in their respective connectors.

● “Mass anode”-type connectors, such as the Catalog Number 5300 series offered by S&C, that have been designated by the connector manufacturer as being suitable for direct attachment to copper-bearing alloy terminals pads.

## Opening and Closing the Switch

### **⚠ DANGER**

The interrupters and terminal pads of the Alduti-Rupter Switch may be energized from either side with the interrupters in any position. Before inspecting, servicing, or repairing this switch or working on the conductors on either side of the switch, test for voltage using proper high-voltage test equipment. Afterward, install suitable grounding equipment at all six terminals.

Failure to observe these precautions may result in serious injury or death.

### **NOTICE**

This interrupter switch is not intended for breaking fault currents.

**STEP 45.** To operate the Alduti-Rupter Switch: Remove the padlock(s) from the hasps on the operating-handle assembly. See Figure 52.

- (a) If the operating handle assembly is furnished with a key interlock, disengage the interlock bolt. See Figure 53.
- (b) Swing the handle *rapidly* to the fully **Open** or fully **Closed** position. See Figure 54.
- (c) Check that all three poles are fully open or fully closed.
- (d) Replace the padlock(s). Engage the key interlock, if applicable.

### **NOTICE**

Swing the operating handle vigorously through its full travel without hesitation. Arcing and damage to the switch will occur if the energized switch is operated slowly or left in the partially **Open** or **Closed** position.

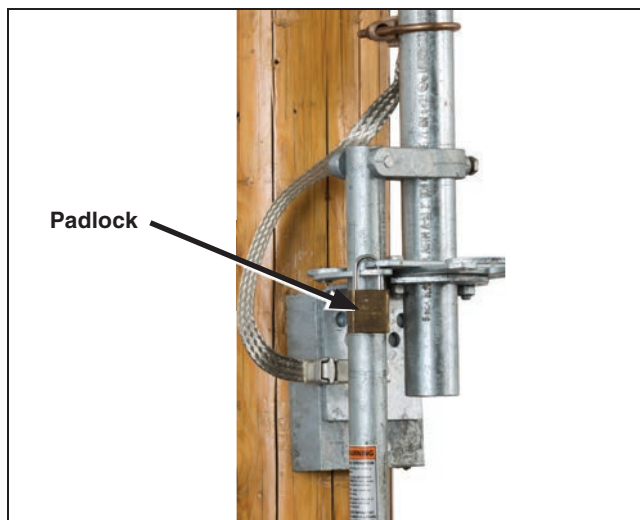

Figure 52. Remove the padlock(s).

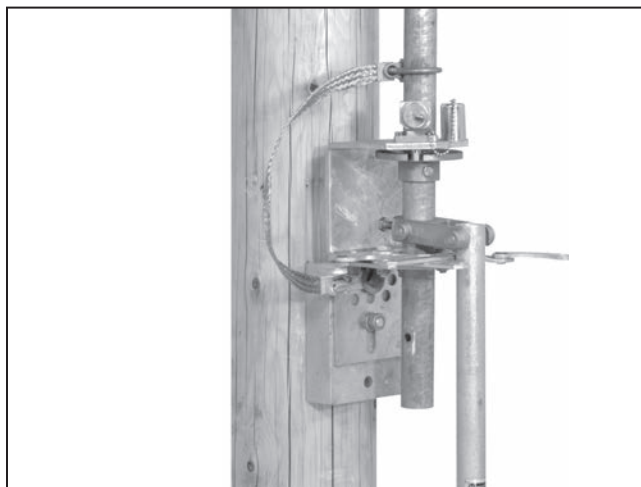

Figure 53. Disengaging the key interlock bolt.

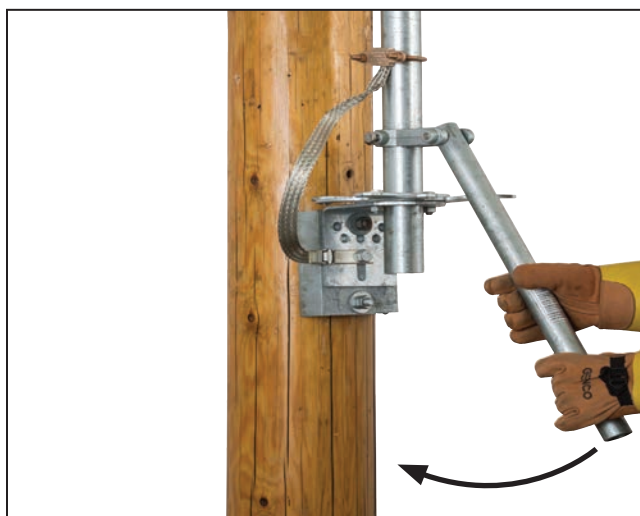

Figure 54. Swing the operating handle rapidly.

