

To ensure a Line-Rupter Switch's continued proper performance, it should be inspected in accordance with the recommended schedule and procedures contained in this publication. Table 1 indicates the inspection frequency for each major Line-Rupter component. Table 2 on page 2 lists a summary of inspection procedures appropriate for each component. Table 3 (optional) on page 3 lists the resistance values for use by customers who take resistance measurements as a part of their standard inspection and maintenance procedure.

If unseen damage to the Line-Rupter Switch's live parts is suspected, resistance values can be measured across specified points on the switch to confirm and isolate damaged portions of the switch. (A standard dc resistance bridge should be used with the measuring points and values specified.)

**Table 1—Recommended Inspection Schedule**

A mechanical-operations test value is indicated in Table 1 for those Line-Rupter components affected by the number of mechanical operations performed. It is a guideline to the number of open-close operations expected for the component before replacement is required.

Electrical-operations limits are also listed for the interrupter and disconnect live parts because these components are affected by the number of electrical operations performed. These limits are dependent upon the Line-Rupter application and magnitude of current switched. For the interrupter and disconnect live parts, the electrical-operations limit provides an overriding guideline to the number of open-close operations expected before replacement is required.

**Table 1. Recommended Inspection Schedule For S&C Line-Rupter Components**

Component	Mechanical-Operations Test Value, ① Number of Open-Close Operations	Electrical-Operations Limit			Inspection Frequency ②										
		Application	Maximum Current, Amperes	Number of Open-Close Operations	Number of Open-Close Operations								Number of Years		
					25	50	75	100	250	500	1 000	2 500			
Switch operator	5 000	—	—	—									●	●	
Power train	2 000	—	—	—									●	●	
Brain	5 000	—	—	—									●	●	
Interrupter	5 000	Load dropping	250	5 000										●◆	●◆
			550	2 000									●◆		
			1 000	1 000									●◆		
			1 200	750									●◆		
			1 600	500									●◆		
Disconnect live parts	5 000	Load splitting (parallel or loop switching)	250	1 000▲											●
			550	500▲											
			1 000	200▲											
			1 200	150▲											
			1 600	100▲											
		2 000	50▲												
		Line switching (charging current)	★	500▲											
Cable switching (charging current)	500	500▲													

① Based on mechanical-operations tests performed by S&C using new Line-Rupter Switches with no intervening maintenance performed.

② Frequently operated Line-Rupter Switches (typically 200 or more open-close operations a year) should be inspected after the first 250 operations; thereafter, they should be inspected at the frequency indicated. Frequently operated Line-Rupter Switches also require annual lubrication of the disconnect live parts. See Table 2 on page 2.

● Recommend inspection frequency.

▲ For Line-Rupter Switches manufactured before 1983, the electrical-operations limit of the disconnect live parts is approximately one half of the value indicated because the closing contacts on these switches apply lower contact pressure. Consequently, the recommended inspection frequency for the disconnect live parts of these switches, in number of open-close operations, is one-half of the value indicated. Present-design closing contacts are available for field retrofit; refer to the nearest S&C Sales Office.

◆ Interrupters should be checked for low gas pressure (red targets) during the user's normal day-to-day operating procedures.

★ Maximum length of line: 300 miles.



# S&C Line-Rupter™ Switches

The actual number of open-close operations for a component will depend upon the nature of the application, the environment (e.g., whether subject to temperature or humidity extremes or highly corrosive or dusty atmospheres), and the observance of the recommended inspection schedule.

An inspection frequency is shown for each component listed. To maximize the operating life of the component, S&C recommends that the user perform the inspection procedures described in Table 2 at the frequency indicated by a “●”—either in number of open-close operations or years, whichever occurs more often. If the inspection results

indicate or if dictated by the mechanical-operations test value or electrical-operations limit guideline, the component should be replaced.

Each user’s own experience will determine whether more frequent inspections are required.

## Table 2—Recommended Inspection Procedures

The Line-Rupter inspection procedures to be followed are summarized in Table 2. The applicable S&C instruction sheets for Line-Rupter Switches should be referenced for further details.

**Table 2. Recommended Inspection Procedures for S&C Line-Rupter Components**

Component	Inspection Procedures
General	<ol style="list-style-type: none"> <li>1. Check with your local S&amp;C Sales Office to see whether there are any outstanding field notifications for inspection, retrofit, or maintenance of your model switch.</li> <li>2. Check the switch for overall cleanliness of the insulators, live parts, and operator. If there is severe contamination, power washing with water or a non-abrasive cleaning method should be performed.</li> </ol>
Switch operator	<ol style="list-style-type: none"> <li>1. Check for evidence of damage, excessive corrosion, or wear.</li> <li>2. Check ease of operation during slow, manual cranking using the switch-operator manual operating handle. Listen for simultaneity of tripping of the interrupters: from the point at which one interrupter trips, no more than 60° of rotation should be required before the other two interrupters trip. If excessive rotation is required, contact the nearest S&amp;C Sales Office.</li> <li>3. Check electrical operation, coupled and decoupled.</li> <li>4. Check for loose wiring inside enclosure and proper functioning of position-indicating lamps, operation counter, convenience lamp, etc.</li> <li>5. Check operation of brake and readjust, if necessary.</li> <li>6. Check key interlocks, if furnished, mechanically and electrically.</li> </ol>
Power train	<ol style="list-style-type: none"> <li>1. Check for evidence of damage, excessive corrosion, or wear.</li> <li>2. Check tightness of fasteners.</li> <li>3. Observe operation during slow, manual cranking using the switch-operator manual operating handle. Check for complete stroking of the various drive levers against their stops and for attainment of over-toggle positions, as required.</li> <li>4. Check condition of seals.</li> </ol>
Brain	<ol style="list-style-type: none"> <li>1. Remove brain cover and check for evidence of water ingress, damage, excessive corrosion, or wear.</li> <li>2. Check tightness of shunt-cable fasteners and for evidence of excessive fraying of the shunt cable.</li> <li>3. Check condition of seals.</li> <li>4. Replace brain cover. Observe operation during slow, manual cranking using the switch-operator manual operating handle. Listen for the tripping action of the interrupter on opening and observe operation of the interrupter targets.</li> <li>5. Check for proper clearances at the brain adjustment-holding device and at the blade crank-arm stop.</li> </ol>
Interrupter	<ol style="list-style-type: none"> <li>1. Check for low gas pressure (red indicator).</li> <li>2. Check tightness of fasteners on current-carrying parts.</li> <li>3. (Optional) Check resistance using the resistance values in Table 3 on page 3.</li> </ol>
Disconnect live parts	<ol style="list-style-type: none"> <li>1. Check for evidence of damage, excessive corrosion, or wear—especially at the closing contacts and current-carrying contacts. Replace current-carrying jaw contacts if the silver-alloy inserts on two or more contact fingers are worn to the extent that the blade tongue contact engages the full width of the contact finger.</li> <li>2. Check tightness of fasteners on current-carrying parts.</li> <li>3. Observe operation during slow, manual cranking using the switch-operator manual operating handle. Check for proper contact alignment.</li> <li>4. Lubricate the contact surfaces with an appropriate lubricant.①</li> </ol>
Bypass accessory	<ol style="list-style-type: none"> <li>1. Check for evidence of damage, excessive corrosion, or wear.</li> <li>2. Check tightness of fasteners on current-carrying parts.</li> <li>3. Observe operation using the stick-operated ratchet mechanism. Check for proper contact alignment.</li> <li>4. Lubricate the contact surfaces with an appropriate lubricant.①</li> </ol>
Grounding switch	<ol style="list-style-type: none"> <li>1. Check for evidence of damage, excessive corrosion, or wear—especially at the jaw-contact alignment.</li> <li>2. Check tightness of fasteners on current-carrying parts.</li> <li>3. Observe operation using manual operating handle. Check for proper contact alignment.</li> <li>4. Lubricate the contact surfaces with an appropriate lubricant.①</li> </ol>

① Shell Gadus® S2 U1000 2 Lubricant Catalog Number 9999-043 is available in 1 oz. tubes from S&C. Shell Darina SD2, Dow 33, or equivalent can be substituted.

**Table 3—Allowable Resistance Values: Line-Rupter Switches, Vertical-Break**

The allowable resistance values indicated in Table 3 are provided for the convenience of users whose practices include measuring and recording the resistance over current-carrying and current-interrupting components of a line switch. Such measurements *are not* required to fulfill the terms of S&C’s

Line-Rupter warranty and should only be made by qualified personnel who are fully trained in the measuring equipment and the techniques for making resistance measurements on high-voltage equipment. The measurements can be used to identify areas of high resistance, to be remedied by cleaning and maintenance, or component replacement.

**Table 3. Allowable Resistance Values for S&C Line-Rupter Switches, Vertical-Break**

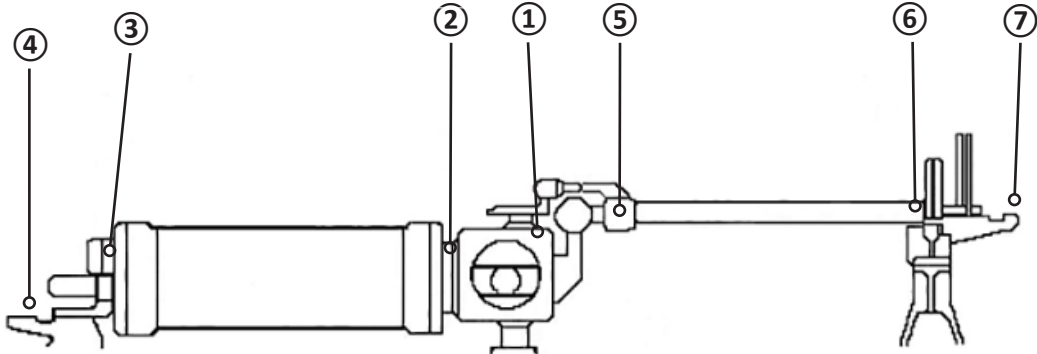

kV	Gaps	Cont., Amperes	1-4■ Microhms	2-3, Interrupter Closed, Microhms	2-3, Interrupter Open, Megohms	1-2★ Microhms	3-4★ Microhms	4-7◆ Microhms	1-5★ Microhms	6-7★ Microhms
115	2	1 200	30	150	208–312	15	15	220	40	40
	2	2 000						180		
138	2	1 200	30	150	208–312	15	15	230	40	40
	2	2 000						190		
161	2	1 200	30	150	208–312	15	15	240	40	40
	2	2 000						200		
230	3	1 600	30	200	312–468	15	15	230	40	40
	3	2 000						210		

- Resistance between points 1 and 4 minus the *actual* resistance of interrupter (closed) (points 2 and 3).
- ◆ Resistance between points 4 and 7 minus the *actual* resistance of interrupter (closed) (points 2 and 3).

★ Use these measurements to locate specific points of high resistance.

**⚠ DANGER**

De-energize and ground the Line-Rupter Switch at all six terminals before making resistance measurements. Follow all applicable safety procedures.

**Failure to de-energize and ground the Line-Rupter Switch before making resistance measurements can result in serious injury or death.**

**Interrupter**

Perform the measurements between points 2 and 3 and points 1 and 4. If one or more of these measurements is over the stated resistance values, use the starred “★” measurements to locate the point(s) of resistance. If the resistance is high between the brain housing and the interrupter (points 1

and 2) or the interrupter and the terminal pad (points 3 and 4), the bolted connections should be disassembled and the hardware re-prepared (surfaces cleaned and a high-voltage grease reapplied) and reassembled. If the location of high resistance is across the interrupter (points 2 and 3), the interrupter should be replaced.

**Blade**

Perform the measurement between points 4 and 7. Subtract the resistance of the interrupter taken when the interrupter points 2 and 3 (closed) were measured. The difference should be lower than number listed in the “4-7” column. If the resistance is higher than listed, use the starred “★” measurements to locate the point(s) of high resistance. Contact your local S&C Sales Office for assistance.