

To ensure a Series 2000 Circuit-Switcher's continued proper performance, it should be inspected in accordance with the recommended schedule and procedures contained in the tables of this publication. Table 1 on page 2 indicates the frequency with which each major component should be inspected on a Series 2000 Circuit-Switcher rated 69 kV through 138 kV; 25 kA fault interrupting. Table 2 on page 2 similarly indicates the frequency with which each major component should be inspected on a Series 2000 Circuit-Switcher rated 69 kV through 138 kV; 40 kA fault interrupting. Table 3 on page 3 lists the frequency for circuit-switchers rated 161 kV or 230 kV. Table 4 on page 4 lists a summary of inspection procedures appropriate for each component.

Tables 1, 2, and 3—Recommended Inspection Schedules

A mechanical-operations test value is indicated in Tables 1 and 2 for those 69-kV through 138-kV Series 2000 Circuit-Switcher components affected by the number of mechanical operations performed. A mechanical-operations test value is also indicated in Table 3 for those 161-kV and 230-kV Series 2000 Circuit-Switcher components affected by the number of mechanical operations performed. Each mechanical-operations test value is offered as a guideline to the number of open-close operations that might reasonably be expected for the component before replacement is required.

Electrical-operations limits are also listed in each table for the interrupter because this component is affected by the number of electrical operations performed. These limits are dependent upon the circuit-switcher application and magnitude of current switched. For the interrupter, the electrical-operations limit thus provides the overriding guideline to the number of **Open/Close** operations that might be expected before replacement is required.

The actual number of **Open/Close** operations that may be obtained for a component in service will depend upon the nature of the application, the installation environment (e.g., whether subject to temperature or humidity extremes, or highly corrosive or dusty atmospheres), and the observance of the recommended inspection schedule.

An inspection frequency is shown for each component listed. To maximize the operating life of the component, it is recommended that the user perform the inspection procedures described in Table 4 at the frequency indicated—either in number of **Open/Close** operations or years, whichever occurs more often. If the inspection results so indicate—or if dictated by the mechanical-operations test value or electrical-operations limit guideline—the component should be replaced.

Each user's own experience will determine whether more frequent inspections are required. Note that for most transformer-protection applications, the first circuit-switcher inspection is recommended at 10 years from the time of delivery and then once every 5 years for units between 10 and 20 years old and once every three years for circuit-switchers more than 20 years old.

Table 4—Recommended Inspection Procedures

The Series 2000 Circuit-Switcher inspection procedures to be followed are summarized in Table 4 on page 4. The applicable S&C instruction sheets for the circuit-switcher, grounding switch, etc., should be referenced for further details.

Table 5—Doble Test Values for Insulating Support Columns

The allowable power-dissipation factors listed in Table 5 on page 6 are indicative of the dielectric integrity of the operating rod and interior of a Series 2000 Circuit-Switcher insulating support column.

Measurement of power dissipation factors on the user's Series 2000 Circuit-Switcher insulating support columns is not required to fulfill the terms of S&C's circuit-switcher warranty and should only be made by qualified personnel who are fully trained in high-voltage measuring equipment and the techniques for taking measurements on high-voltage equipment.

Tables 6, 7, and 8—Resistance Values for Live-Parts

The allowable resistance values listed in Tables 6, 7, and 8 on pages 6 through 8 are provided for the convenience of users whose practices include measuring and recording the resistance over current-carrying and current-interrupting components of a circuit-switcher.

If unseen damage to the Series 2000 Circuit-Switcher's live parts is suspected, resistance values can be measured across specified points on the device to confirm and isolate the damaged portions. A standard dc resistance bridge should be used with the measuring points and values specified. Such measurements are not required to fulfill the terms of S&C's circuit-switcher warranty and should only be made by qualified personnel who are fully trained in the measuring equipment and the techniques for taking resistance measurements on high-voltage equipment. The measurements can be used to identify areas of high resistance, to be remedied by cleaning and maintenance or component replacement. Contact your local S&C Sales Office if more information on taking resistance measurements is required.



Table 1—Recommended Inspection Schedule for 69-kV Through 138-kV; 25 kA Fault Interrupting Series 2000 Circuit-Switcher Components

Component	Mechanical-Operations Test Value, ^① Number of Open-Close Operations	Electrical-Operations Limit			Inspection Frequency ^②	
		Application	Maximum Current, Amperes	Number of Open-Close Operations	Number of Open-Close Operations	Number of Years
Operator, interrupter power train, insulating support column, and disconnect power train	5 000	—	—	—	1 500	★
Interrupter	5 000	Capacitor, reactor, or load switching	200	5 000	1 500◆	★◆
			600	3 000		
		Load switching	1 200	1 500	Not applicable	
		Primary-fault Interrupting	25 000	10		
		Secondary-fault Interrupting	4 000	25		
		Fault closing	25 000	5		
40 000	1					
Disconnect live parts	5 000	—	—	—	Not applicable	★
Bypass accessory	—	—	—	—	Not applicable	★
Grounding switch	—	—	—	—	Not applicable	★
Remote gas-density monitor	—	—	—	—	Not applicable	8

① Based on mechanical-operations tests performed by S&C using new circuit-switchers with no intervening maintenance performed.

② Frequently operated circuit-switchers (typically 200 or more **Open/Close** operations per year) should be inspected after the first 250 operations; thereafter, they should be inspected at the frequency indicated. Frequently operated circuit-switchers also require annual lubrication of the disconnect live parts. See Table 4 on pages 4 and 5.

◆ On circuit-switchers not equipped with a remote gas-density monitor, interrupters should be checked for low gas pressure (red targets) during the user's normal day-to-day operating routine.

★ First inspection at 10 years from delivery, 5 years for circuit-switchers between 10 and 20 years old, and 3 years for circuit-switchers more than 20 years old.

Table 2—Recommended Inspection Schedule for 69-kV Through 138-kV; 40 kA Fault Interrupting Series 2000 Circuit-Switcher Components

Component	Mechanical-Operations Test Value, ^① Number of Open-Close Operations	Electrical-Operations Limit			Inspection Frequency ^②	
		Application	Maximum Current, Amperes	Number of Open-Close Operations	Number of Open-Close Operations	Number of Years
Operator, interrupter power train, insulating support column, and disconnect power train	2 000	—	—	—	1 000	★
Interrupter	2 000	Load switching	1 200	1 500	1 500◆	★◆
		Primary-fault Interrupting	40 000	5		
		Secondary-fault Interrupting	4 000	25	Not applicable	
		Fault closing	40 000	5		
Disconnect live parts	2 000	—	—	—	1 000	★
Bypass accessory	—	—	—	—	Not applicable	★
Grounding switch	—	—	—	—	Not applicable	★
Remote gas-density monitor	—	—	—	—	Not applicable	8

① Based on mechanical-operations tests performed by S&C using new circuit-switchers with no intervening maintenance performed.

② Frequently operated circuit-switchers (typically 200 or more **Open/Close** operations per year) should be inspected after the first 250 operations; thereafter, they should be inspected at the frequency indicated. Frequently operated circuit-switchers also require annual lubrication of the disconnect live parts. See Table 4 on pages 4 and 5.

◆ On circuit-switchers not equipped with a remote gas-density monitor, interrupters should be checked for low gas pressure (red targets) during the user's normal day-to-day operating routine.

★ First inspection at 10 years from delivery, 5 years for circuit-switchers between 10 and 20 years old, and 3 years for circuit-switchers more than 20 years old.

Table 3—Recommended Inspection Schedule for 161-kV and 230-kV Series 2000 Circuit-Switcher Components

Component	Mechanical-Operations Test Value, ^① Number of Open-Close Operations	Electrical-Operations Limit			Inspection Frequency ^②	
		Application	Maximum Current, Amperes	Number of Open-Close Operations	Number of Open-Close Operations	Number of Years
Operator, interrupter power train, insulating support column, and disconnect power train	1 500	—	—	—	750	★
Interrupter	1 500	Load switching	1 200	1 500	750◆	★◆
		Primary-fault Interrupting	20 000	10	Not applicable	
		Secondary-fault Interrupting	4 000	25		
		Fault closing	20 000	5		
40 000	1					
Disconnect live parts	1 500	—	—	—	750	★
Bypass accessory	—	—	—	—	Not applicable	★
Grounding switch	—	—	—	—	Not applicable	★
Remote gas-density monitor	—	—	—	—	Not applicable	8

① Based on mechanical-operations tests performed by S&C using new circuit-switchers with no intervening maintenance performed.

② Frequently operated circuit-switchers (typically 200 or more **Open/Close** operations per year) should be inspected after the first 250 operations; thereafter, they should be inspected at the frequency indicated. Frequently operated circuit-switchers also require annual lubrication of the disconnect live parts. See Table 4 on pages 4 and 5.

◆ On circuit-switchers not equipped with a remote gas-density monitor, interrupters should be checked for low gas pressure (red targets) during the user's normal day-to-day operating routine.

★ First inspection at 10 years from delivery, 5 years for circuit-switchers between 10 and 20 years old, and 3 years for circuit-switchers more than 20 years old.

⚠ DANGER

De-energize and ground the circuit-switcher at all six terminals before performing the inspection procedures described on the following pages. Follow all applicable safety procedures. **Failure to de-energize and ground the circuit-switcher before performing inspection procedures can result in serious injury or death.**

Table 4—Recommended Inspection Procedures for Series 2000 Circuit-Switcher Components

Component	Inspection Procedures
General	1. Check with your local S&C Sales Office to determine whether there are any outstanding field notifications for inspection, retrofit, or maintenance of your model switch. 2. Check overall cleanliness of the insulators, live parts, and operator. If severe contamination is present, power wash with water or use non-abrasive cleaner. Reapply lubricant to live parts after washing.①
Operator	1. Check for evidence of water ingress, wildlife intrusion, damage, excessive corrosion, or wear. 2. Check for loose wiring inside enclosure and proper functioning of position-indicating lamps, operation counter, convenience lamp, etc. 3. On circuit-switchers manufactured between 1998 and July 2007, verify that Solenoid Latch Assembly with Trip Assist Mechanism, Catalog Number SXA-4612-1-A (48 vdc) or SXA-4612-2-A (125 vdc), has been installed. The Trip Assist Mechanism is visible at the top of the latch assembly, as shown in Figure 1. If it has not been installed on a unit supplied between 1998 and July 2007, plan to retrofit the latch assembly. 4. Perform several test operations. Check electrical operation using TRIP and CLOSE pushbuttons. Also check the operation using the manual trip lever. Replace components that don't work properly or exhibit excessive corrosion. 5. Simulate a fault by activating protective-relay circuit. Check electrical operation. 6. Check key interlocks, if furnished, mechanically and electrically.

① Shell Gadus® S2 U1000 2 Lubricant Catalog Number 9999-043 is available in 1 oz. tubes from S&C. Shell Darina SD2, Dow 33, or equivalent can be substituted.

Table continued ►

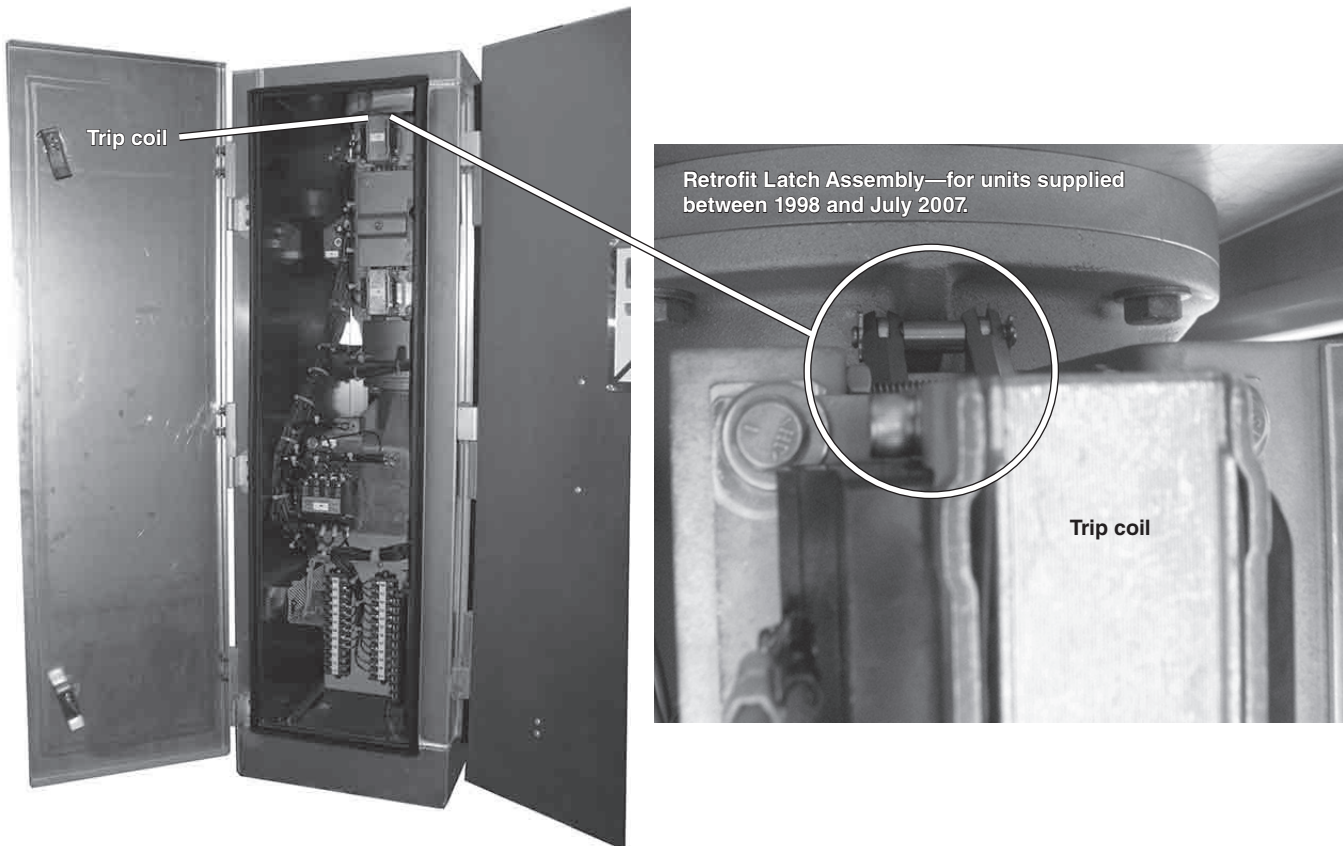

Figure 1. Operator—side door

Table 4—Recommended Inspection Procedures for Series 2000 Circuit-Switcher Components—Continued

Component	Inspection Procedures
Insulating support column	<p><i>A set of spare support columns should be in stock for use in the event replacement is necessary.</i></p> <ol style="list-style-type: none"> 1. Check the bottom seal for evidence of leaking lubricated dielectric filler: stains on base, stains on gravel beneath column, and/ or dirt on underside of lower porcelain skirts. Circuit-Switchers supplied through August 1998 are at greater risk of this condition. On 161-kV or 230-kV circuit-switchers with two-piece insulating support columns, also check the seal at the middle joint of column for evidence of leaking lubricated dielectric filler. Leaking columns on a 161- or 230-kV circuit-switchers should be replaced as soon as possible. Consider changing all three insulating support columns manufactured between 1986 and August 1998 while the unit is out of service. The serial number will be stamped into the metal base of the column. The column serial numbers are between BB-223-01 (August 1986) and PP-163-06 (May 1998) for these units. A leaking column on a 69-, 115-, or 138-kV circuit-switchers does not need to be replaced unless there is evidence of water ingress inside the transition box or Doble readings are above the levels shown in Table 5 on page 6. 2. Remove the transition box cover at the top of the column and check that pinned the connections are secure. Also check for evidence of water ingress, damage, excessive corrosion, or wear. If there is evidence of water ingress and the column is also leaking dielectric fluid, replace the leaking insulator support column and contact S&C for assistance in determining how the moisture entered the column. 3. On models with integral disconnect, close the disconnect. Check that the rotating-spindle closed-stop bolt on the insulating support column is within 1/16 inch of the bumper at the bottom of the transition box. <p>Note: Many utilities have started using Doble testing to verify the integrity of different types of insulation. Although S&C does not recommend performing this type of test, it has provided Table 5 on page 6 to show the maximum acceptable test values for insulating support columns.</p>
Interrupter power train	<ol style="list-style-type: none"> 1. Remove bottom covers from base and check power train and bumpers for evidence of damage, excessive corrosion, or wear, and replace components as needed. 2. Check that bolted connections are tight and pinned connections are secure.
Disconnect power train	<ol style="list-style-type: none"> 1. Check for evidence of damage, excessive corrosion, or wear. 2. Check that bolted connections are tight and pinned connections are secure. 3. Check condition of seals.
Interrupter	<ol style="list-style-type: none"> 1. Check for low gas pressure (red indicator). 2. For circuit-switchers manufactured from 1986 to 1995, inspect the red target assembly of each interrupter to verify proper function of the red target. To perform this inspection, obtain the inspection tool kit SXA-4578 and follow the instructions per RD-6933. If the inspection determines that the red target is not functioning properly, plan to install a retrofit red target assembly. Contact your local S&C Sales Office for more information. Note: If updated red target assembly (kit number SXA-4268R1 for Model 2010, 2030, and 2040, and kit number SXA-4587 for Model 2020) has been installed, this inspection step is not needed. If you would like to obtain this assembly for retrofit, please contact your local S&C Sales Office. 3. Check that bolted connections are tight on current-carrying parts. 4. If desired, check resistance as indicated in Table 6, Table 7, or Table 8 on pages 6 through 8.
Bypass accessory	<ol style="list-style-type: none"> 1. Check for evidence of damage, excessive corrosion, or wear. 2. Check that bolted connections are tight on current-carrying parts. 3. Observe operation using stick-operated ratchet mechanism. Check for proper contact alignment. 4. Lubricate contact surfaces with an appropriate lubricant. ①
Grounding switch	<ol style="list-style-type: none"> 1. Check for evidence of water ingress, damage, excessive corrosion, or wear—especially at the jaw-contact members. 2. Check that bolted connections are tight on current-carrying parts. 3. Observe operation using manual operating handle. Check for proper contact alignment. 4. Lubricate the contact surfaces with an appropriate lubricant. ①
Remote gas-density monitor	<ol style="list-style-type: none"> 1. Replace transmitter batteries at least once every eight years.

① Shell Gadus® S2 U1000 2 Lubricant Catalog Number 9999-043 is available in 1-oz. tubes from S&C. Shell Darina SD2, Dow 33, or equivalent can be substituted.

⚠ DANGER

De-energize and ground the circuit-switcher at all six terminals before making Doble test measurements on the insulating support columns. Follow all applicable safety procedures. **Failure to de-energize and ground the circuit-switcher before making Doble test measurements can result in serious injury or death.**

Table 5—Doble Test Values for Series 2000 Circuit-Switcher Insulating Support Columns—Watts Loss

Voltage, kV	Maximum Power Dissipation Factor, Watts
69	0.16
115	0.13
138	0.13
161	0.10
230	0.10

Note: Many utilities have started using Doble testing to verify the integrity of different types of insulation. Although S&C does not recommend performing

this type of test, it has provided Table V to show the maximum acceptable test values for insulating support columns.

Table 6—Allowable Resistance Values: Series 2000 Circuit-Switcher Model 2010

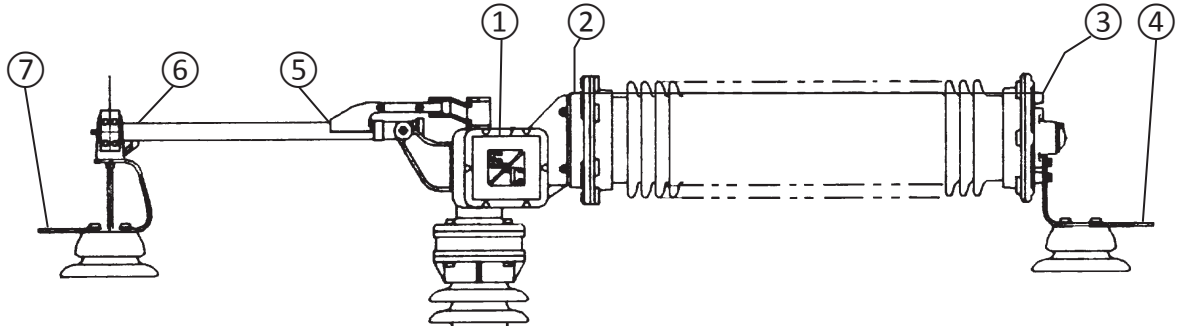

Voltage, kV	Continuous Current, Amperes	Measurement Points, Microhms						
		2-3	1-4	1-2★	3-4★	4-7▲	1-5★	6-7★
69	1 200	200	260	30	30	220	50	75
115						265		
138						285		
161		265						
230		285						
60	2 000	180	240	30	30	175	50	40
115						205		
138						225		

▲ Resistance between points 4 and 7 minus actual resistance of interrupter (between points 2 and 3).

⚠ DANGER

De-energize and ground the circuit-switcher at all six terminals before making resistance measurements. Follow all applicable safety procedures. **Failure to de-energize and ground the circuit-switcher before making resistance measurements can result in serious injury or death.**

Interrupter

Perform the measurements between points 2 and 3 and points 1 and 4. If one or more of these measurements is over the stated resistance values, use the starred “★” measurements to locate the point(s) of resistance. If the resistance is high between the transition box housing and the terminal pads (points 1

and 4), the bolted connections should be disassembled and the hardware should be re-prepared (surfaces cleaned and a high-voltage grease reapplied) and replaced. If the location of high resistance is across the interrupter (points 2 and 3), the interrupter should be replaced.

Blade

Perform the measurement between points 4 and 7. Subtract the resistance of the interrupter taken when the interrupter points 2 and 3 were measured. The difference should be lower than number listed in the “4-7” column. If the resistance is higher than listed, use the starred “★” measurements to locate the point(s) of high resistance. Contact your local S&C Sales Office for assistance.

Table 7—Allowable Resistance Values: Series 2000 Circuit-Switcher Model 2020

Voltage, kV	Continuous Current, Amperes	Measurement Points, Microhms							
		2-3	1-4	1-2★	3-4★	4-8▲	1-5★	6-7★	7-8★
69	1 200	200	300	30	70	220	30	50	40
115						265			
138						285			

▲ Resistance between points 4 and 8 minus actual resistance of interrupter (between points 2 and 3).

⚠ DANGER

De-energize and ground the circuit-switcher at all six terminals before making resistance measurements. Follow all applicable safety procedures. **Failure to de-energize and ground the circuit-switcher before making resistance measurements can result in serious injury or death.**

Interrupter

Perform the measurements between points 2 and 3 and points 1 and 4. If one or more of these measurements is over the stated resistance values, use the starred “★” measurements to locate the point(s) of resistance. If the resistance is high between the transition box housing and the terminal pads, (points 1

and 4) the bolted connections should be disassembled and the hardware should be re-prepared (surfaces cleaned and a high-voltage grease reapplied) and replaced. If the location of high resistance is across the interrupter (points 2 and 3) the interrupter should be replaced.

Blade

Perform the measurement between points 4 and 8. Subtract the resistance of the interrupter taken when the interrupter points 2 and 3 were measured. The difference should be lower than number listed in the “4-8” column. If the resistance is higher than listed, use the starred “★” measurements to locate the point(s) of high resistance. Contact your local S&C Sales Office for assistance.

Table 8—Allowable Resistance Values: Series 2000 Circuit-Switcher Models 2030 and 2040

Voltage, kV	Continuous Current, Amperes	Measurement Points, Microhms			
		2-3	1-4	1-2★	3-4★
69	1 200	250	310	30	30
115					
138					
161					
230	300	360			
69	2 000	180	240		
115					
138					

⚠ DANGER

De-energize and ground the circuit-switcher at all six terminals before making resistance measurements. Follow all applicable safety procedures. **Failure to de-energize and ground the circuit-switcher before making resistance measurements can result in serious injury or death.**

Interrupter

Perform the measurements between points 2 and 3 and between points 1 and 4. If one or more of these measurements is over the stated resistance values, use the starred “★” measurements to locate the point(s) of resistance. If the resistance is high between the transition box housing and the terminal pads, (points 1 and 4), the bolted connections should be disassembled and the hardware should be reprepared (surfaces cleaned and a high-voltage grease reapplied) and replaced. If the location of high resistance is across the interrupter (points 2 and 3), the interrupter should be replaced.