

Installation

Table of Contents

Introduction	2	Wiring and Adjusting the Switch Operator	32
Qualified Persons	2	Before Starting	32
Read This Instruction Sheet	2	Connecting Control Power and User-Furnished	
Retain This Instruction Sheet	2	Control Circuits	33
Proper Application	2	Using the Manual Operating Handle.....	35
Safety Information	3	Using the Selector Handle (Coupling and	
Understanding Safety-Alert Messages	3	Decoupling)	36
Following Safety Instructions.....	3	Adjusting the Switch Operator	38
Replacement Instructions and Labels	3	Terminal Pads and Conductor Connections ..	50
Location of Safety Labels	4	Installing the Terminal Pad	50
Safety Precautions	5	Connecting Conductors	51
Shipping and Handling	6	Circuit-Switcher Startup and Checkout	52
Inspection	6	Startup	52
Packaging	6	Checkout	55
Storage	6	Indicators	57
Installation	7	Understanding the Interrupter Indicators.....	57
Before Starting	7	Understanding the Gas-Pressure Gauge	58
Installing the Mounting Pedestals and		Understanding the Optional Remote	
Support Structure	8	Gas-Density Indicator	60
Installing the Gearbox.....	11		
Installing the Disconnect Pole-Units	12		
Installing the Interrupters, Motor Brackets,			
and Buswork	13		
Checking Operation of Disconnect	19		
Installing the Drive Train.....	21		
Installing the Mark VI CS-1A Switch Operator.....	23		
Installing the Interrupter Charging Motors	26		
Installing the Conduit Assembly.....	28		
Wiring the Interrupters and Charging Motors	29		



Introduction

Qualified Persons

WARNING

Only qualified persons knowledgeable in the installation, operation, and maintenance of overhead and underground electric distribution and transmission equipment, along with all associated hazards, may install, operate, and maintain the equipment covered by this publication. A qualified person is someone trained and competent in:

- The skills and techniques necessary to distinguish exposed live parts from nonlive parts of electrical equipment
- The skills and techniques necessary to determine the proper approach distances corresponding to the voltages to which the qualified person will be exposed
- The proper use of special precautionary techniques, personal protective equipment, insulated and shielding materials, and insulated tools for working on or near exposed energized parts of electrical equipment

These instructions are intended only for such qualified persons. They are not intended to be a substitute for adequate training and experience in safety procedures for this type of equipment.

Read This Instruction Sheet

NOTICE

Thoroughly and carefully read this instruction sheet and all materials included in the product's instruction handbook before installing or operating the S&C Mark VI Circuit Switcher. Become familiar with the Safety Information on pages 3 through 4 and Safety Precautions on page 5. The latest version of this publication is available online in PDF format at [sandc.com/en/contact us/product literature/](http://sandc.com/en/contact-us/product-literature/).

Retain This Instruction Sheet

This instruction sheet is a permanent part of the Mark VI Circuit Switcher. Designate a location where users can easily retrieve and refer to this publication.

Proper Application

WARNING

The equipment in this publication is only intended for use in the switching and protection of capacitor banks and substation transformers. The applications must be within the ratings furnished for the equipment. The ratings for this Mark VI Circuit-Switcher are listed on the nameplate on the side of the Mark VI CS-1A Switch Operator. They can also be found in S&C Specification Bulletin 712-31.

Understanding Safety Alert Messages

Several types of safety alert messages may appear throughout this instruction sheet and on labels and tags attached to the product. Become familiar with these types of messages and the importance of these signal words:

⚠ DANGER
“DANGER” identifies the most serious and immediate hazards that will likely result in serious personal injury or death if instructions, including recommended precautions, are not followed.

⚠ WARNING
“WARNING” identifies hazards or unsafe practices that can result in serious personal injury or death if instructions, including recommended precautions, are not followed.

⚠ CAUTION
“CAUTION” identifies hazards or unsafe practices that can result in minor personal injury if instructions, including recommended precautions, are not followed.

NOTICE
“NOTICE” identifies important procedures or requirements that can result in product or property damage if instructions are not followed.

Following Safety Instructions

If any portion of this instruction sheet is unclear and assistance is needed, contact the nearest S&C Sales Office or S&C Authorized Distributor. Their telephone numbers are listed on S&C’s website sandc.com, or call the S&C Global Support and Monitoring Center at 1 888 762 1100.

NOTICE	
Read this instruction sheet thoroughly and carefully before installing the S&C Mark VI Circuit Switcher.	

Replacement Instructions and Labels

If additional copies of this instruction sheet are required, contact the nearest S&C Sales Office, S&C Authorized Distributor, S&C Headquarters, or S&C Electric Canada Ltd.

It is important any missing, damaged, or faded labels on the equipment be replaced immediately. Replacement labels are available by contacting the nearest S&C Sales Office, S&C Authorized Distributor, S&C Headquarters, or S&C Electric Canada Ltd.

Location of Safety Labels

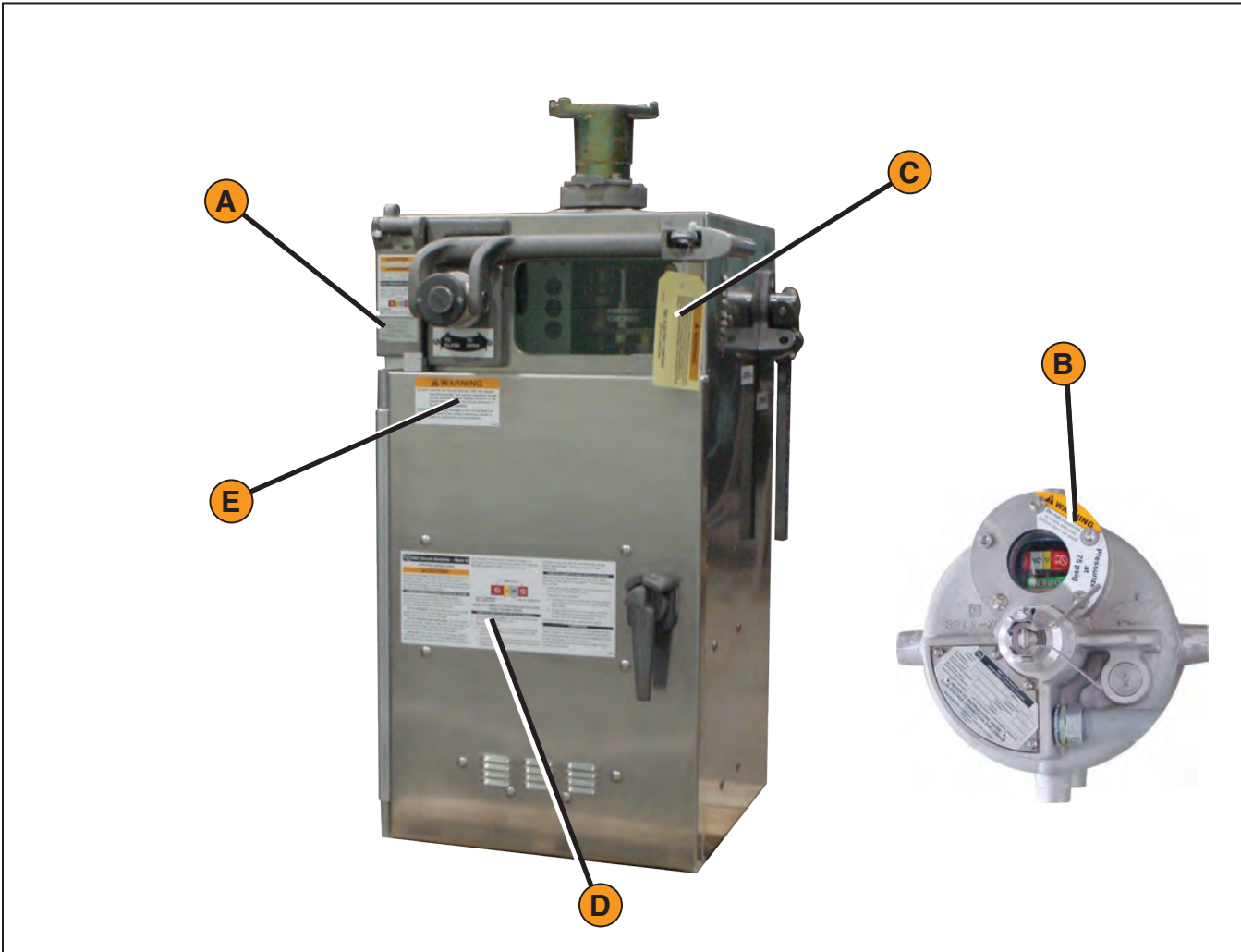

Reorder Information for Safety Labels

Location	Safety Alert Message	Description	Part Number
A	⚠ WARNING	Use push button control to open or close ...	G 9025
B	⚠ WARNING	Do not disassemble or modify ...	G 7015 5
C	⚠ WARNING	Do not operate the Circuit Switcher with ...	G 9024
D	⚠ WARNING	Unauthorized changes should not be made ...	G 9027
E	⚠ WARNING	Do not operate the Circuit Switcher with ...	G 9026
F	NOTICE	This contactor or relay has been blocked...	G 3684R4●■
G	NOTICE	The S&C Instruction Sheet is a permanent part...	G 3733R2■
H	NOTICE	Auxiliary switch cams are individually adjustable.	G 4746R2■

- Label should be removed before placing the circuit switcher in service.
- Label is inside the operator and not visible in photo.

⚠ DANGER



Mark VI Circuit-Switchers operate at high voltage. Failure to observe the precautions below will result in serious personal injury or death.

Some of these precautions may differ from your company's operating procedures and rules. Where a discrepancy exists, follow your company's operating procedures and rules.

- | | |
|--|--|
| <ol style="list-style-type: none"> 1. QUALIFIED PERSONS. Access to substation switching equipment must be restricted only to qualified persons. See "Qualified Persons" on page 2. 2. SAFETY PROCEDURES. Always follow safe operating procedures and rules. 3. PERSONAL PROTECTIVE EQUIPMENT. Always use suitable protective equipment such as rubber gloves, rubber mats, hard hats, safety glasses, and flash clothing in accordance with safe operating procedures and rules. 4. SAFETY LABELS. Do not remove or obscure any of the "DANGER," "WARNING," "CAUTION," or "NOTICE" labels. 5. ENERGIZED COMPONENTS. Always consider all parts live until de-energized, tested, and grounded. Voltage levels can be as high as the peak line-to-ground voltage last applied to the unit. Units that have been energized or installed near energized lines should be considered live until tested and grounded. 6. GROUNDING. The Mark VI Circuit-Switcher must be connected to a suitable earth ground at the | <p>base of the utility pole, or to a suitable building ground for testing, before energizing the switch and at all times when energized.</p> <p>The ground wire(s) must be bonded to the system neutral, if present. If the system neutral is not present, proper precautions must be taken to ensure the local earth ground, or building ground, cannot be severed or removed.</p> <ol style="list-style-type: none"> 7. CIRCUIT-SWITCHER POSITION. Always confirm the Open/Close position of circuit-switchers by visually observing the position of the blades. Switches may be energized from either side and with the blades in either position. 8. MAINTAINING PROPER CLEARANCE. Always maintain proper clearance from energized components. 9. OPERATION. Circuit making and breaking is involved in the normal operation of this interrupter switch and, as a result, "partway" opening or closing is undesirable. To operate, follow the operating procedure as outlined in S&C Instruction Sheet 712-501. |
|--|--|

Shipping and Handling

Inspection

Examine the shipment for external evidence of damage as soon after receipt as possible, preferably before removal from the carrier's conveyance. Check the bill of lading to make sure all listed shipping skids, crates, and containers are present.

If there is visible loss and/or damage:

1. Notify the delivering carrier immediately.
2. Ask for a carrier inspection.
3. Note condition of shipment on all copies of the delivery receipt.
4. File a claim with the carrier.

If concealed damage is discovered:

1. Notify the delivering carrier within 15 days of receipt of shipment.
2. Ask for a carrier inspection.
3. File a claim with the carrier.

Also, notify S&C Electric Company in all instances of loss and/or damage.

Packaging

An S&C reference drawing (RD) is in a water-resistant envelope attached to the interrupter container on one of the three circuit-switcher pole-unit disconnects. A packing list is included. Use the packing list to confirm all parts have been received before beginning assembly. Keep the packing list for future reference.

The Mark VI Circuit-Switcher shipment includes all three phases of the integral disconnect mounted on a single skid. Each phase is factory-assembled and adjusted. Drive-train operating shafts, interphase couplings, mounting hardware, and a temporary hand adapter for checking the operation of the integral disconnects—all individually identified—are also packed with the disconnect pole-units. The shafts are cut to length.

Three interrupters are packed in a separate crate along with associated mounting hardware. Three interrupter charging motors and their associated mounting hardware are packed in a separate crate. The Mark VI CS-1A Switch Operator is shipped on a separate skid.

S&C Mounting Pedestals consist of a set of two pedestals of square steel tube construction complete with circuit-switcher support frame. Mounting pedestals are shipped on separate skids. If furnished, options such as a grounding switch or pre-insertion inductors are shipped in their own crates.



WARNING

DO NOT disassemble or modify the interrupters. The interrupters are pressurized at 75 PSIG. **Serious injury can result.**

Storage

NOTICE

The Mark VI CS-1A Switch Operator is equipped with a space heater that must be energized during storage to prevent condensation and corrosion within the operator enclosure.

If the circuit-switcher must be stored before installation, keep it in a clean, dry, corrosion-free area to protect it from damage. Make sure each skid rests firmly on the ground and is reasonably level. Shoring under the skids may be necessary if the ground is uneven.

If storing outdoors, connect control power to the space heater inside the Mark VI CS-1A Switch Operator per the wiring diagram furnished. Inspect the circuit-switcher regularly when storing for prolonged periods.

Before Starting**⚠ WARNING**

The foundations for S&C Mounting Pedestals must be designed to meet the loading limits specified in S&C Information Bulletin 712-60. **Failure to meet these loading requirements can result in equipment damage and personal injury.**

NOTICE

A crane or other suitable lifting device is required to install the Mark VI Circuit-Switcher. Make sure an appropriate lifting device is available at the installation site before beginning the circuit-switcher installation.

- STEP 1.** Cut the steel straps binding the mounting pedestals, cross base, and support structure. Unbolt the cross base from the pedestals, if necessary, and unbolt the mounting pedestals from the skids.
- STEP 2.** Before removing the disconnect pole-units from the skid, arrange the skid on a level surface, in the position and order in which they will be raised onto the cross base, as shown on the associated reference drawing (RD).
- STEP 3.** Unbolt the wooden cross braces securing the disconnect pole-units to each other. Do not unbolt the disconnect pole-units from the base of the shipping skid at this time. See Figure 1.

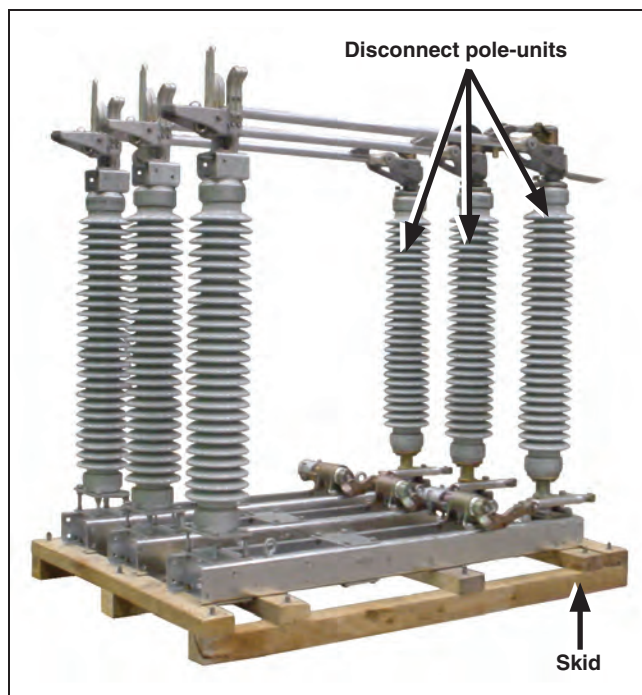

Figure 1. Remove all packing materials from the disconnect pole-units. Do not unbolt the disconnects from the skid until lifting slings are attached.

Installation

Installing the Mounting Pedestals and Support Structure

Complete the following steps to install and mount the pedestals and support structure:

STEP 1. Install each pedestal as follows:

- (a) Before lifting, make sure the grounding pad is positioned properly for the installation and the support arms are positioned in the correct direction. Refer to the accompanying reference drawing (RD) for details. See Figure 2.
- (b) Install the support arms to the nut plates inside the pedestal using four $\frac{5}{8}$ -11 \times 2 $\frac{1}{4}$ -inch hex-head cap screws and flat washers furnished. (Pedestals less than 12 feet (366 cm) in height will have their support arms pre-installed.)
- (c) Attach lifting slings to the eyebolts provided, and lift into place onto the pre-installed anchor bolts, nuts, and flat washers. After positioning the pedestal, loosely secure a flat washer and nut to each anchor bolt. Remove lifting slings.
- (d) Adjust the lower set of anchor-bolt nuts to plumb and level the pedestal. The upper set of anchor-bolt nuts should remain loosely attached. See Figure 3. Repeat this step for the remaining pedestal.

STEP 2. Place a pedestal cover on top of each pedestal and align it with the holes on the pedestal. See Figure 2.

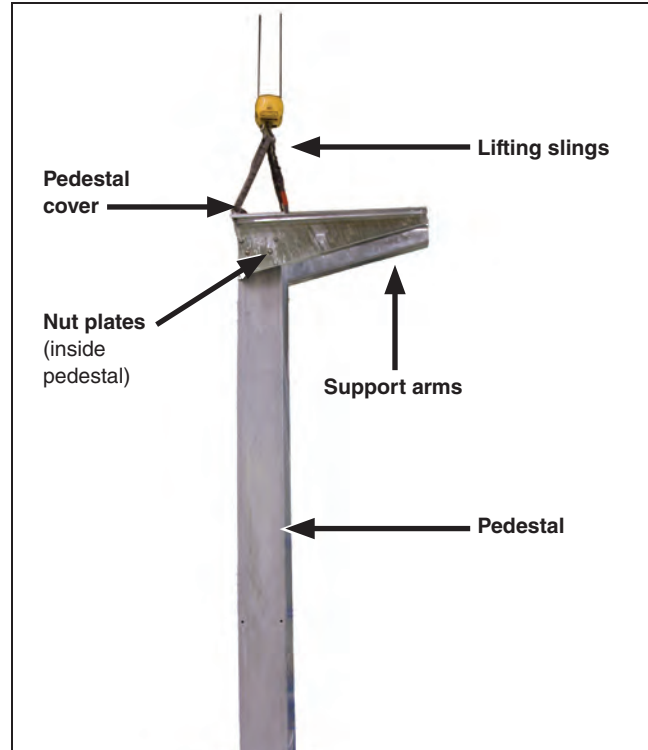

Figure 2. Attach lifting slings to the eyebolts provided and lift into place on the user-furnished pre-installed foundation.

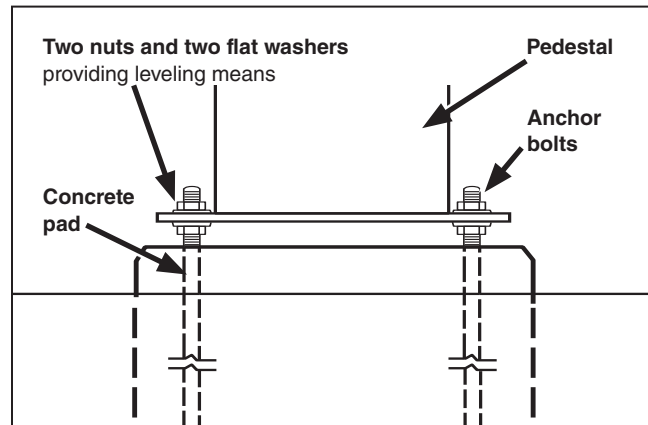

Figure 3. Adjust the anchor-bolt nuts to plumb and level the pedestals.

- STEP 3.** Lift the switch base as follows:
- (a) Attach suitable lifting slings to the switch base using the eyebolts provided. See Figure 4.
 - (b) Lift the switch base and place it on top of the support arms.
 - (c) Align the switch base with the holes in the support arms and the pedestals. Take care not to damage the pedestal covers. (Refer to the associated reference drawing if the position of the mounting holes is unclear.)

- STEP 4.** Using the eight $\frac{5}{8}$ -11 \times 2 $\frac{1}{4}$ -inch hex-head cap screws, flat washers, and self-locking hex nuts furnished, secure the switch base to the support arms and pedestals.

Move the switch base stiffening plates on top of either end of the switch base to the mounting holes underneath the switch base, as shown in Figure 5. The stiffening plates are installed on the top of the base for shipping purposes.

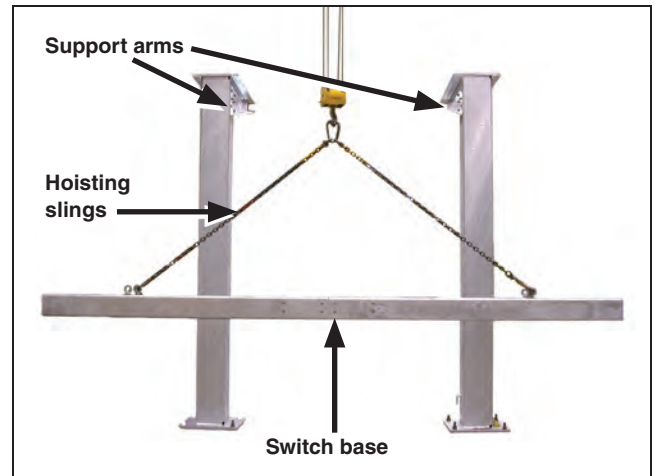

Figure 4. Hoist the switch base into position on top of the pedestals and support arms.

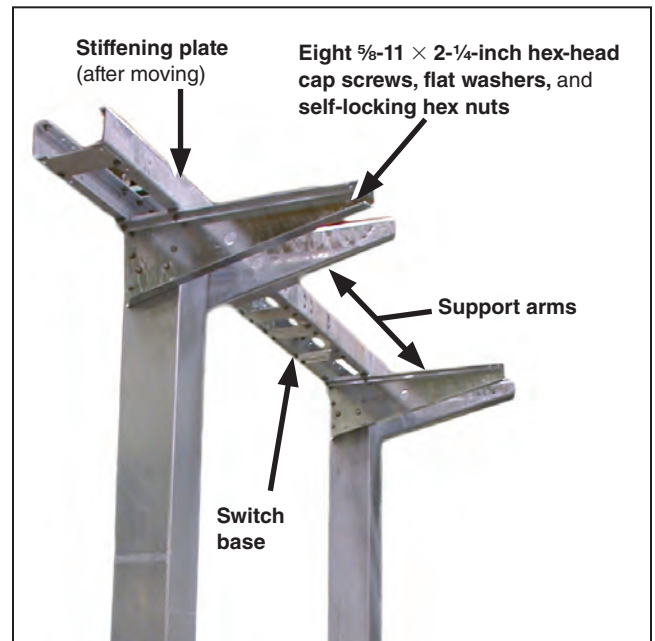

Figure 5. Secure the switch base to the pedestals and support arms. Move the end stiffening plates to the underside of the switch base.

Installation

STEP 5. Lift and install the channel assembly as follows:

- (a) Attach four suitable lifting slings to the channel assembly using the eyebolts provided. See Figure 6.
- (b) Lift the channel assembly and place it on top of the support arms. Using the provided spacers to attain the correct mounting height, align the channel assembly with the holes in the support arms. (Refer to the associated reference drawing if the position of the mounting holes is unclear.)
- (c) Secure the spacers to the support arms using four $\frac{5}{8}$ -11 \times $2\frac{1}{4}$ -inch hex-head cap screws, flat washers, and self-locking hex nuts furnished. Align the channel assembly with the empty set of holes in the spacer and support arms, and secure with the remaining four $\frac{5}{8}$ -11 \times $2\frac{1}{4}$ -inch hex-head cap screws, flat washers, and self-locking hex nuts furnished. See Figure 6 and Figure 7.
- (d) Remove the lifting slings.

STEP 6. Make sure the channel assembly and switch base are level, and remove any remaining eyebolts from the switch base and channel assembly.

Check the lower set of anchor-bolt nuts at each mounting pedestal to verify each is in contact with the bottom of the plate. Hand-tighten these anchor-bolt nuts as needed. See Figure 8.

STEP 7. Securely tighten the upper set of anchor-bolt nuts. See Figure 8.

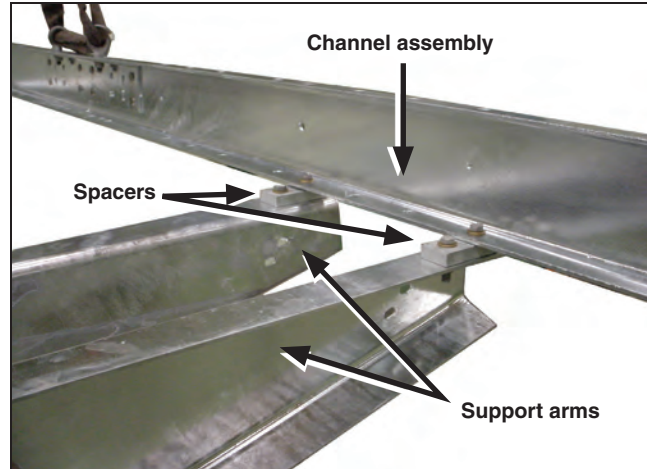

Figure 6. Lift the channel assembly and secure to support arms. Use spacers to achieve the correct mounting height.

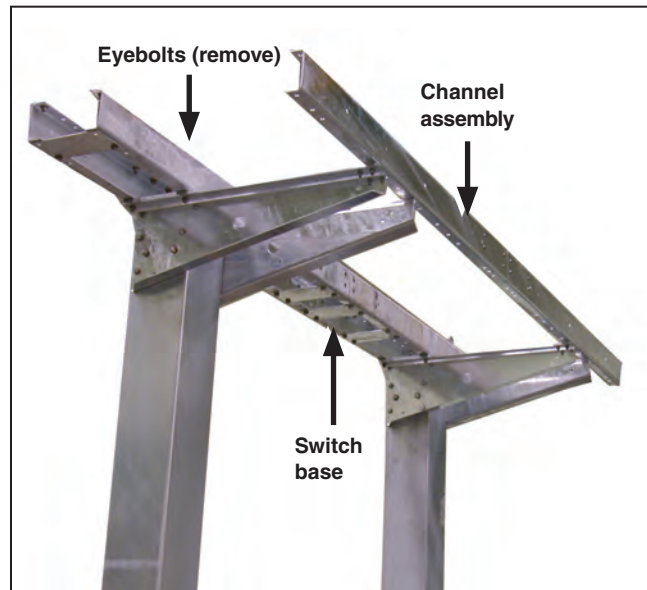

Figure 7. Check the switch base and channel assembly to make sure they are level. Remove the eyebolts.

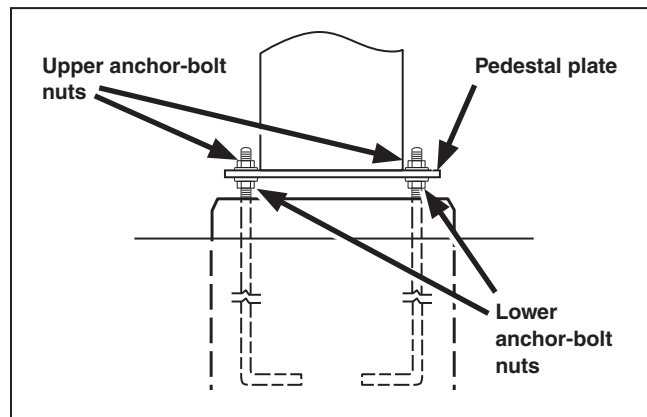

Figure 8. Hand-tighten the lower nuts and securely tighten the upper set of anchor-bolt nuts at each mounting pedestal.

STEP 8. Attach the cross braces to the underside of the switch base and channel assembly as shown on the appropriate reference drawing (RD). Secure the cross braces to the switch base and channel assembly using the four $\frac{5}{8}$ -11 \times 2 $\frac{1}{4}$ -inch hex-head cap screws, flat washers, and self-locking hex nuts furnished. See Figure 9.

Installing the Gearbox

Install the gearbox as follows:

STEP 1. Wrap appropriate lifting slings around the gearbox, between the rigid couplings and the main body of the gearbox, and lift it into place on the switch base. The lower coupling should be centered between the support arms over the pedestal to which the Mark VI CS-1A Switch Operator will also be mounted.

STEP 2. Secure the gearbox to the switch base with four $\frac{5}{8}$ -11 \times 2 $\frac{1}{4}$ -inch hex-head cap screws, eight flat washers (two per joint), and self-locking hex nuts furnished. See Figure 10.

NOTICE

When properly installed, the arrow on the gearbox should face the direction indicated on the reference drawing.

NOTICE

Installing the gearbox before installing the disconnect pole-units minimizes the chance of insulator damage.

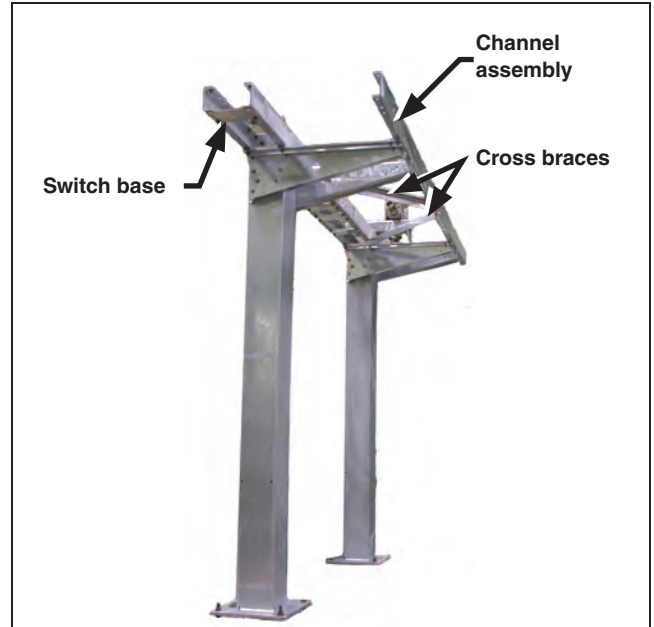

Figure 9. Install the cross braces to complete the structure assembly.

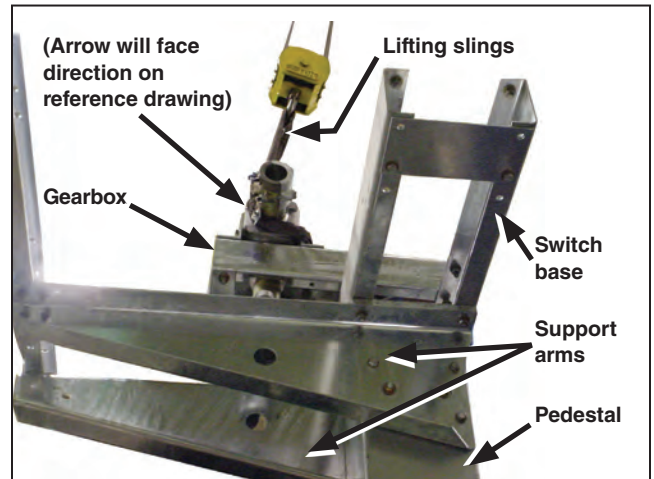

Figure 10. Install the gearbox.

Installation

Installing the Disconnect Pole-Units

Repeat Step 1 through Step 3 for each disconnect pole-unit.

STEP 1. Attach lifting slings to the eyebolts furnished on the disconnect pole-unit base. With the blade in the fully **Closed** position, unbolt the first pole-unit to be installed from the skid. Refer to the reference drawing (RD) for the correct sequence of pole-unit installation.

WARNING

Do not lift the disconnect pole-unit by the disconnect blade, contacts, or other live parts. Keep the blade in the **Closed** position during handling. Avoid sudden stops and starts. **Misalignment and damage to the disconnect and personal injury can occur if not lifted properly.**

STEP 2. Make sure the rigging does not stress the blade or blade contacts. Raise the disconnect to the appropriate elevation and position it over the correct set of mounting holes in the switch base and channel assembly. Avoid sudden starts and stops, and avoid contact with other objects. Refer to the associated reference drawing (RD) for details. See Figure 11.

STEP 3. Bolt the hinge end of the disconnect pole-unit to the switch base using four $\frac{5}{8}$ -11 \times $2\frac{1}{4}$ -inch hex-head cap screws, flat washers, and hex nuts furnished. Bolt the jaw end of the disconnect pole unit to the channel assembly using two $\frac{5}{8}$ -11 \times $2\frac{1}{4}$ -inch hex-head cap screws, flat washers, and self-locking hex nuts furnished. See Figure 12.

Remove the lifting slings and remove the eyebolts and discard.

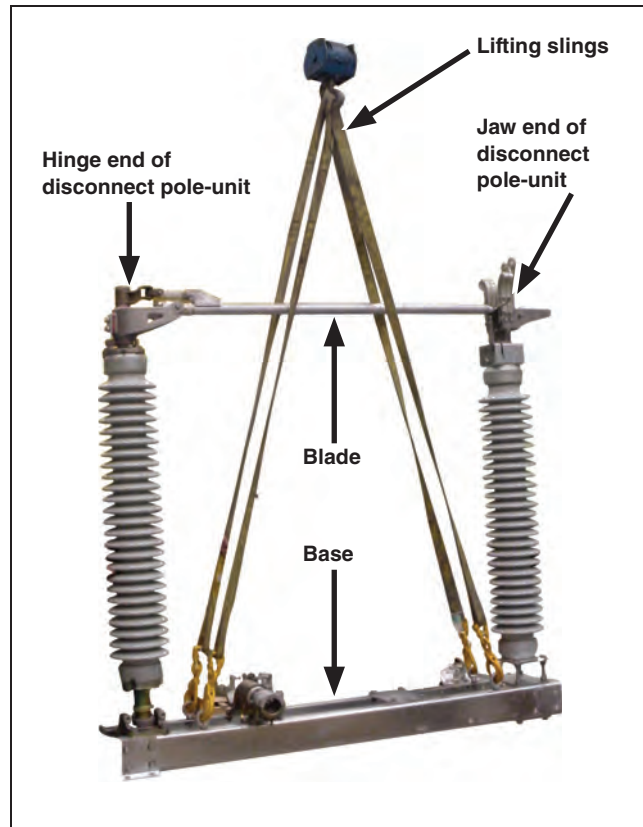

Figure 11. Attach lifting slings to the disconnect pole-unit and raise into place on the structure.

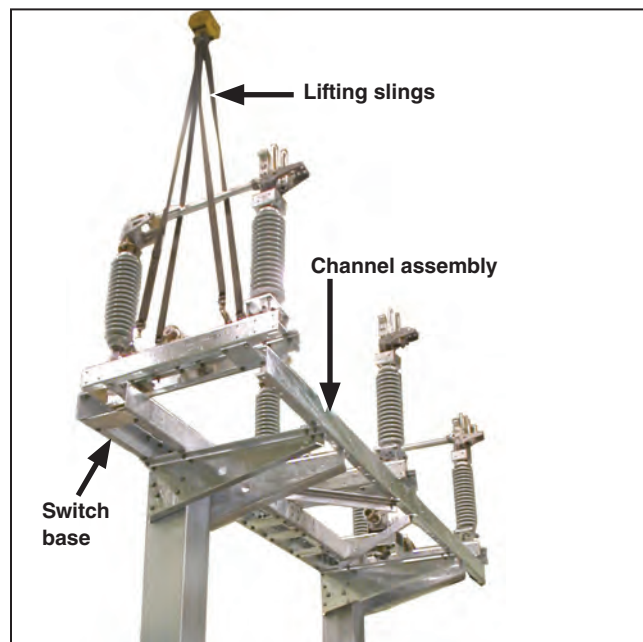

Figure 12. Secure the disconnect pole-unit to the switch base and channel assembly.

Installing the Interrupters, Motor Brackets, and Buswork

Repeat Step 1 through Step 10 for each disconnect pole-unit.

STEP 1. Remove the interrupter from its shipping crate and lift it using the following procedure:

NOTICE

Lift the interrupter **ONLY** by its lifting bracket. **Lifting it by any other means can damage the interrupter.**

- (a) Wrap a lifting sling around the lifting bracket at the top of the interrupter.
- (b) Carefully raise the interrupter upward. The foam wrappings around the top, mid-section, and base should have come off as the interrupter is being lifted. Remove these wrappings if they do not come off by themselves. Do not remove the shipping brace at this time. See Figure 13, Figure 14, and Figure 15.

NOTICE

Do not remove the shipping brace around the base of the interrupter at this time. **Damage to the operating shaft can occur.**

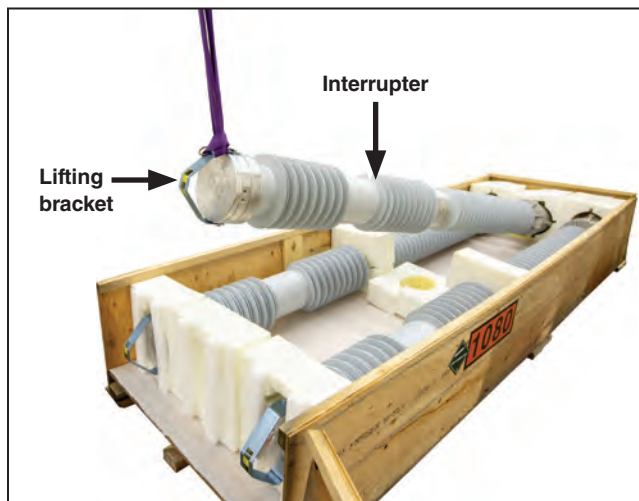

Figure 13. Lift the interrupter only by the lifting bracket.

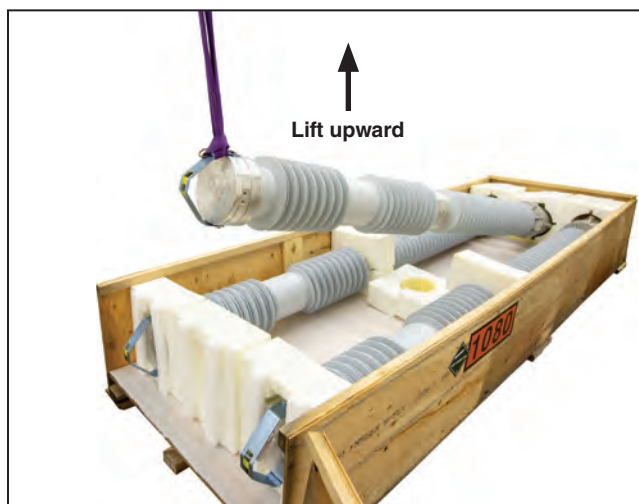

Figure 14. Lift the interrupter carefully upward.

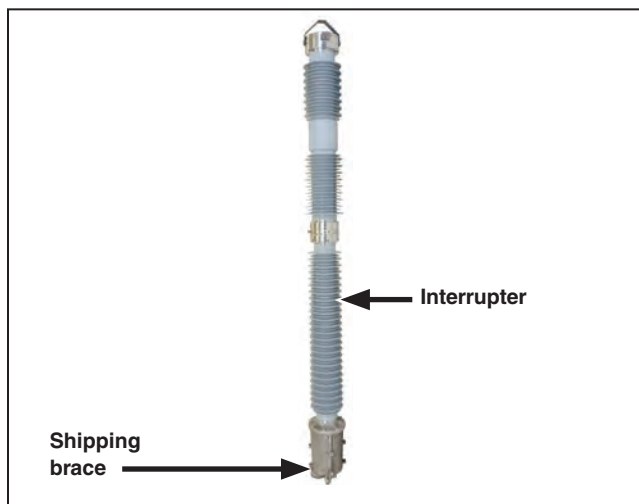

Figure 15. The interrupter with wrappings removed.

Installation

STEP 2. With the interrupter lifted off the ground, make sure the gas-pressure gauge on the underside of the interrupter is in the OK to Operate zone. See Figure 16 and Figure 17.

NOTICE

If the gas pressure gauge needle is not in the OK to Operate zone, stop the installation and notify S&C Electric Company.

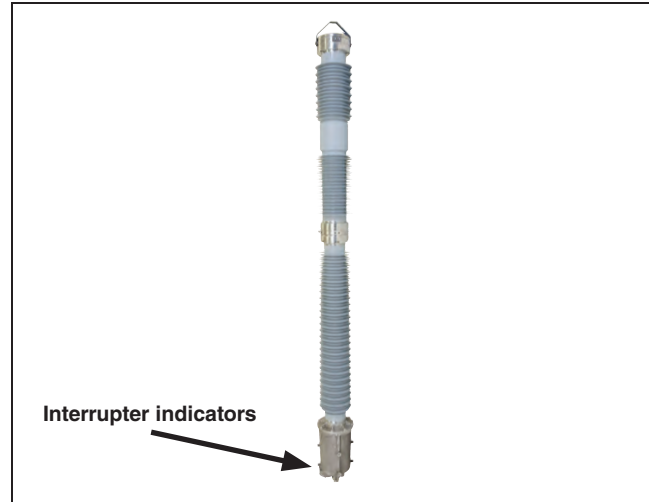

Figure 16. With the interrupter lifted off the ground, check the gas-pressure gauge on the underside of each interrupter.

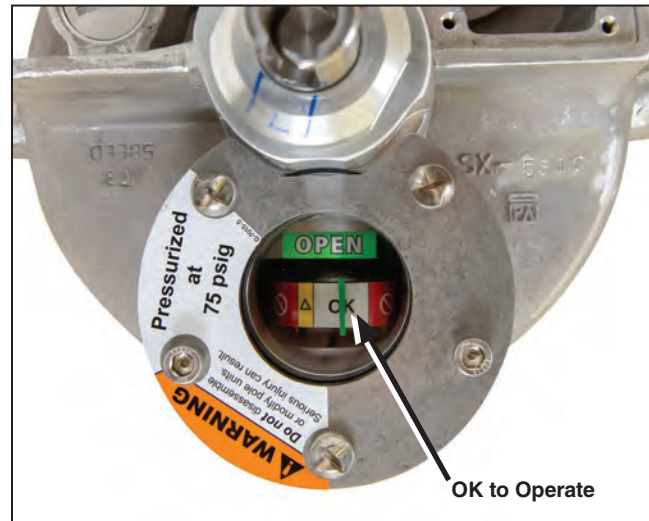

Figure 17. Make sure the gas-pressure gauge on each interrupter is in the OK to Operate zone.

STEP 3. Remove the shipping brace from the interrupter base. See Figure 18.

NOTICE
Do not rest the interrupter on its base after the shipping brace has been removed. Damage to the operating shaft can occur.

STEP 4. With the interrupter still hoisted off the ground, loosely assemble the two interrupter support brackets, the cross-support bracket, and the motor brackets to the interrupter base as shown in Figure 19, using eight stainless steel $\frac{3}{8}$ -11 \times 2-inch studs, flat washers, and self-locking hex nuts furnished. The motor bracket should be mounted between the cross-support bracket and the interrupter mounting bosses, with the L-shaped portion of the bracket facing away from the indicator window. See Figure 20.

NOTICE
The interrupter mounting brackets for 69-, 115-, and 138-kV switches differ slightly in shape and mounting configuration. Take care not to intermix parts from different switch installations. Refer to the associated reference drawing for details.

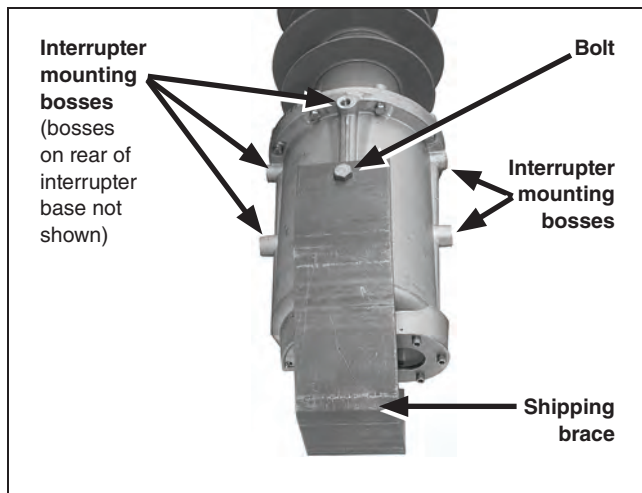

Figure 18. Remove shipping brace.

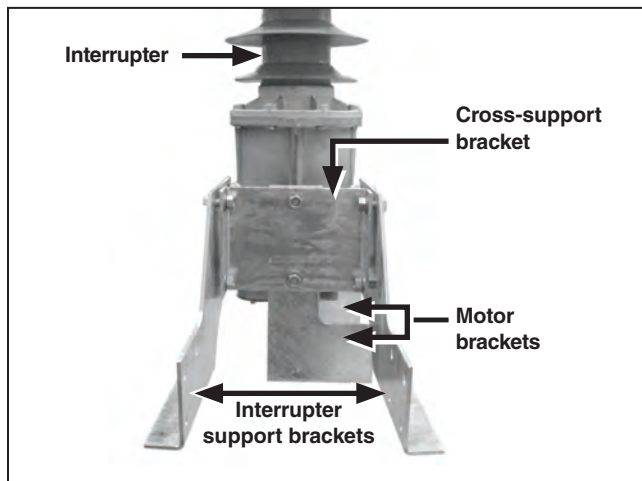

Figure 19. Assemble mounting brackets to interrupter. (69-kV support brackets shown.)

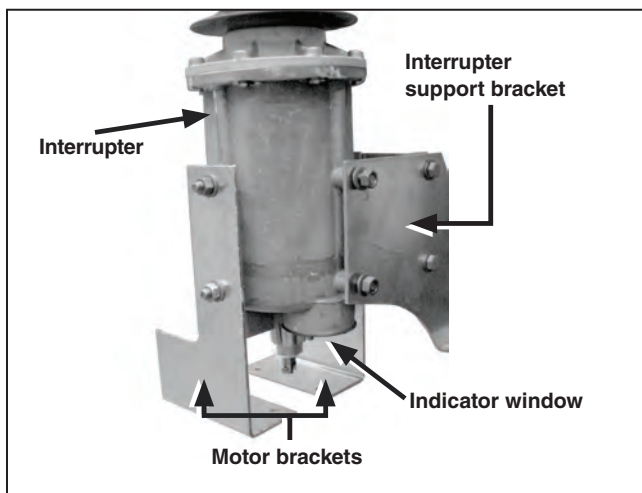

Figure 20. Make sure “L” shaped motor brackets are facing away from the indicator window.

Installation

STEP 5. Position the interrupter mounting brackets so the holes in the brackets align with the holes in the disconnect pole-unit base. See Figure 21. Attach the interrupter mounting brackets to the disconnect pole-unit base using eight $\frac{5}{8}$ -11 \times 2 $\frac{1}{4}$ -inch hex-head cap screws, flat washers, and self-locking hex nuts furnished.

STEP 6. Tighten all $\frac{5}{8}$ -inch stud nuts to a torque of 70 to 80 ft.-lbs. Tighten all $\frac{1}{2}$ -inch hex-head bolt nuts to a torque of 40 to 50 ft.-lbs.

WARNING

Never exceed the recommended torque limit. The interrupter base is pressurized to 75 PSI. **Damage to the interrupter and personal injury can occur.**

STEP 7. Remove the lifting sling from the interrupter.

STEP 8. The interrupter-to-disconnect buswork assemblies are pre-assembled to ensure correct hardware placement. Unfasten all hardware before installation. Prepare the electrical bus connection to the interrupter as follows:

- (a) Thoroughly clean the interrupter bus with a soft cloth. Wire-brush the interrupter casting.
- (b) Immediately apply a liberal coating of Burndy Penetrox® A or other suitable aluminum connector compound to the clean surfaces.
- (c) Apply a coating of Penetrox A to the threads of two $\frac{1}{2}$ -13 \times 1-inch hex-head stainless steel cap screws furnished.
- (d) Attach the interrupter bus to the set of tapped holes in the interrupter using the coated cap screws and two stainless steel lock washers furnished. See Figure 22. Tighten the screws to a torque of 40 to 50 ft.-lbs.

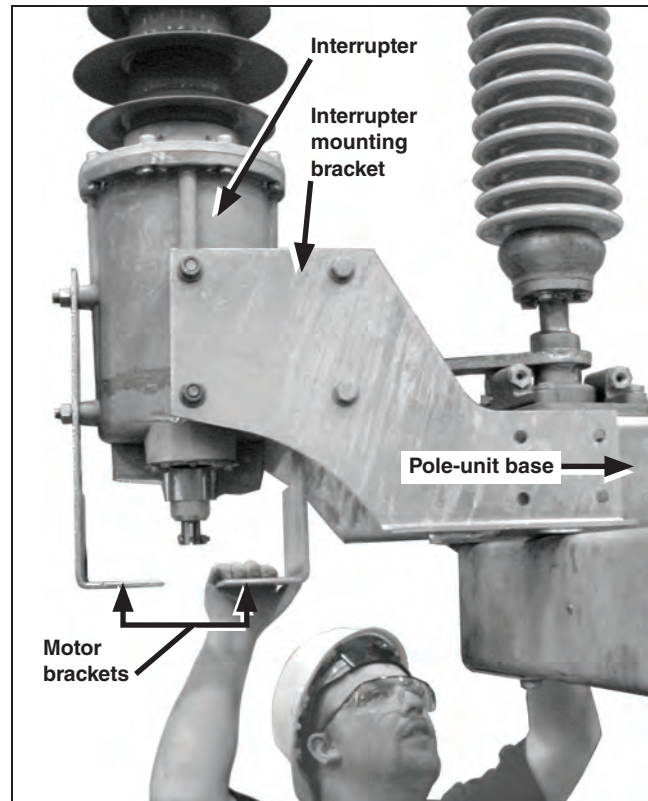

Figure 21. Attach interrupter mounting bracket to pole-unit base. Tighten hardware.

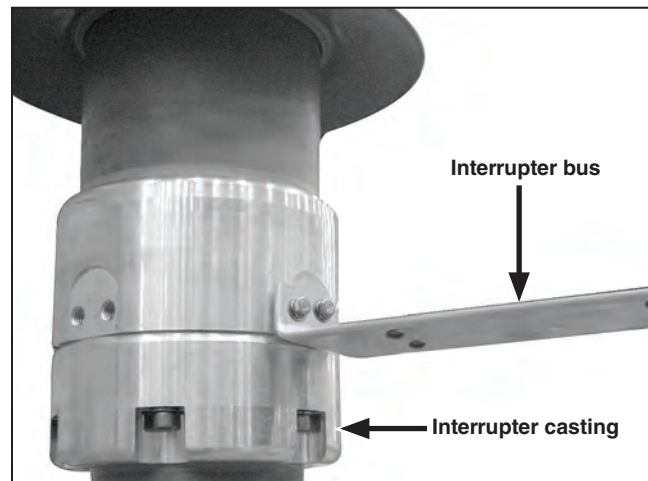

Figure 22. Attach the interrupter bus to the tapped holes on the interrupter casting.

NOTICE

DO NOT wire-brush the buswork. The buswork pieces are plated and do not require abrasive cleaning as a part of their preparation. Wipe any dirt or grease from the surface and apply a thick coating of Penetrox A or other appropriate conductor preparation compound. Wire-brushing can damage the plating and cause corrosion.

STEP 9. Prepare the electrical connection to the disconnect bus as follows:

- (a) Thoroughly clean the disconnect bus with a soft cloth. Wire-brush the disconnect casting.
- (b) Immediately apply a liberal coating of Burndy Penetrox® A or other suitable aluminum connector compound to the clean surfaces.
- (c) Apply a coating of Penetrox A to the threads of four $\frac{1}{2}$ -13 \times $1\frac{1}{4}$ -inch hex-head stainless steel cap screws furnished.
- (d) Attach the disconnect bus to the set of tapped holes in the disconnect casting using the coated cap screws and four $\frac{1}{2}$ -inch stainless steel Belleville washers furnished. See Figure 23. Tighten the screws to a torque of 40 to 50 ft.-lbs.

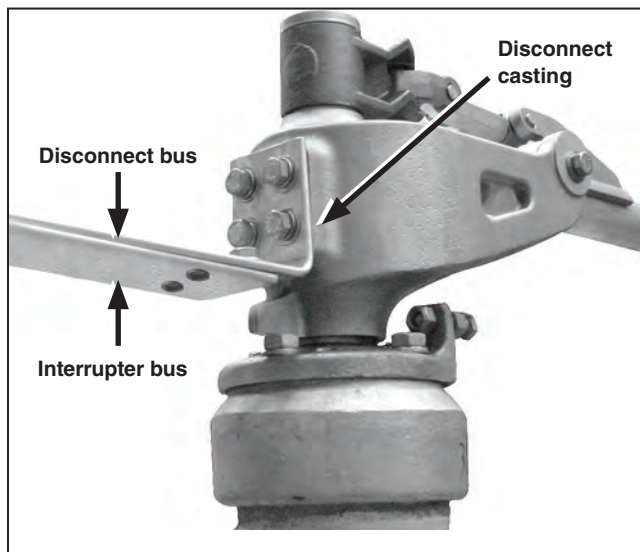

Figure 23. Attach the disconnect bus to the tapped holes in the disconnect casting. Overlap the interrupter bus.

Installation

STEP 10. Attach the interrupter bus to the disconnect bus using four $\frac{1}{2}$ -13 \times $1\frac{1}{2}$ -inch hex-head stainless steel cap screws, Belleville washers, and hex nuts furnished. See Figure 24.

Avoid excess tension or torque between the interrupter bus and the disconnect bus. If the holes between the two sections of buswork do not line up properly, loosen the hardware securing the interrupter mounting brackets to the disconnect base, and shift the interrupter until the holes are aligned. Retighten the interrupter hardware to a torque of 40 to 50 ft.-lbs. if necessary.

⚠ WARNING

Never exceed the recommended torque limit. The interrupter base is pressurized to 75 PSI. **Damage to the interrupter and personal injury can occur.**

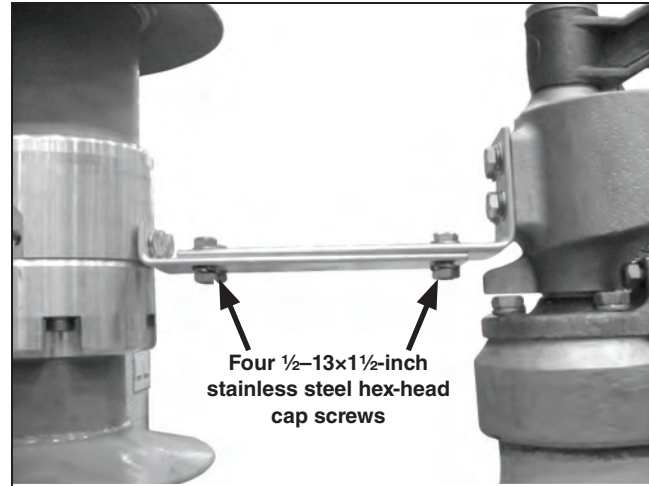

Figure 24. Attach the interrupter bus to the disconnect bus.

Checking Operation of Disconnect

Repeat Step 1 through Step 3 for each disconnect pole-unit.

- STEP 1.** Check operation of the blade using the following procedure:
- Bolt the TEMPORARY MANUAL OPERATING handle to the disconnect drive-shaft crank. See Figure 25. Firmly crank the disconnect to its fully **Open** position. Visually check the disconnect blade opens to an angle of 90° to 96° from horizontal. See Figure 26.
 - If the blade does not open 90° to 96° , shim underneath the disconnect base as required to make up for any irregularities or distortion in the mounting surface and/or readjust the pedestal to level the disconnect bases.
 - Make sure the disconnect pole-unit base is level and the interrupter is vertically aligned with the disconnect pole-unit insulators.

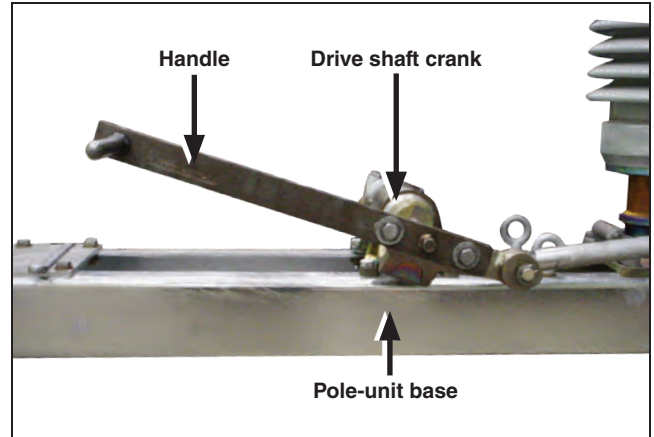

Figure 25. Attach the TEMPORARY MANUAL OPERATING handle to the drive-shaft crank.

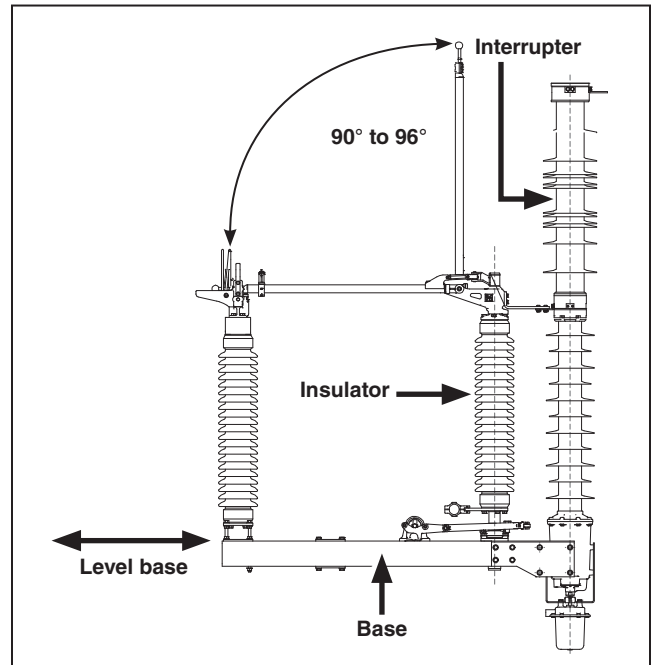

Figure 26. Check the angle of the disconnect blade.

Installation

STEP 2. Check the operation of the blade for proper alignment of the blade with the jaw-contact assembly. As the blade is closed, the fault-closing tongue contact should engage each of the fault-closing jaw contacts with equal pressure, and the current-carrying tongue contact should enter the current-carrying jaw contacts with equal clearance on each side.

The silver-surfaced area of the current-carrying tongue contacts should center laterally with the silver-surfaced current-carrying jaw contacts, and the blade should rotate with slight pressure against the blade bumper stop and come to rest either on the stop or slightly above it. See Figure 27.

STEP 3. Close the disconnect and remove the TEMPORARY MANUAL OPERATING handle.

NOTICE

If the blade angle is not attained or the contacts are not properly aligned after leveling the disconnect base, stop the installation and contact S&C Electric Company.

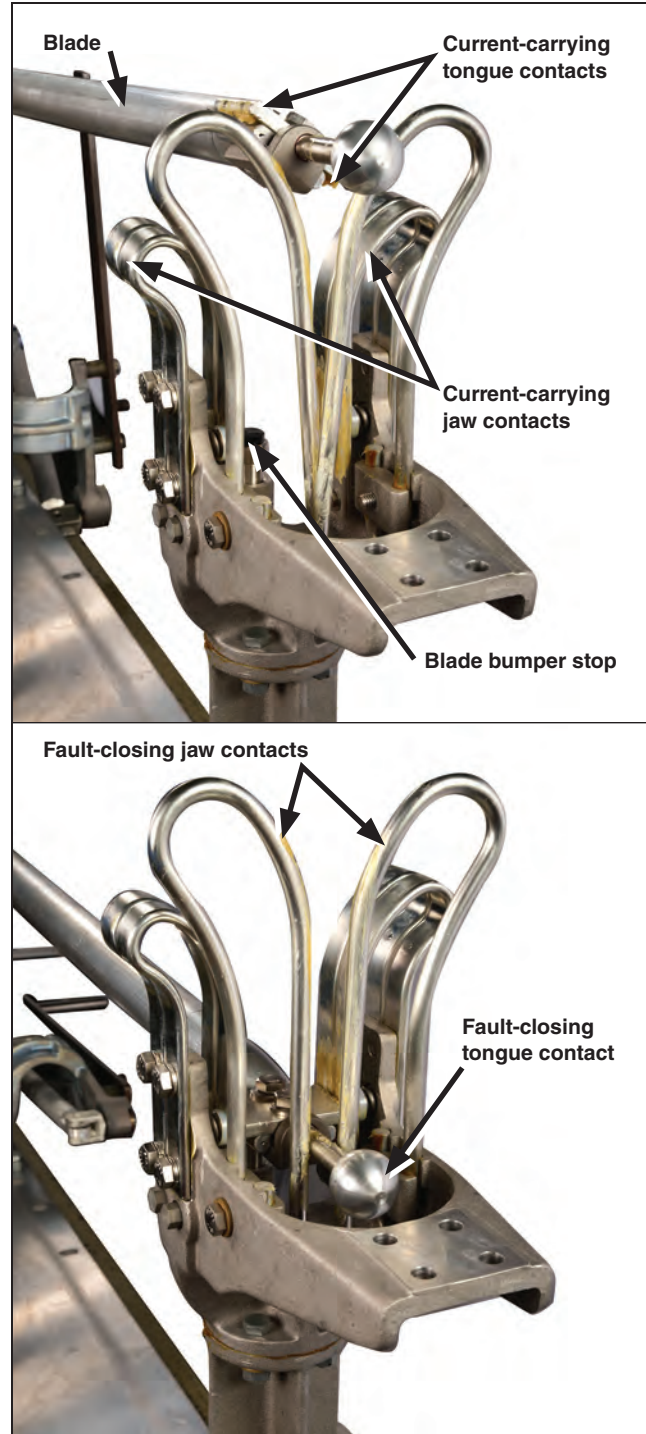

Figure 27. Check penetration of the blade into the jaw contact during closing.

Installing the Drive Train

The drive train is comprised of several sections of interphase shaft connecting the three pole-units to each other, a section of vertical operating shaft directly driven by the Mark VI CS-1A Switch Operator, and a gearbox connecting the vertical operating shaft to the interphase shaft. See Figure 28.

STEP 1. Before installing the interphase shaft sections, attach all flexible coupling assemblies to the disconnect drive shafts where indicated on the reference drawing.

Note: The rigid couplings to and from the gearbox are factory-installed to the gearbox. For some phase spacings, a short flanged section of interphase shaft is provided to make the connections between the gearbox and the surrounding pole-units. Refer to the reference drawing for specific details on the interphase shaft arrangement. See Figure 28 for a typical drive train arrangement.

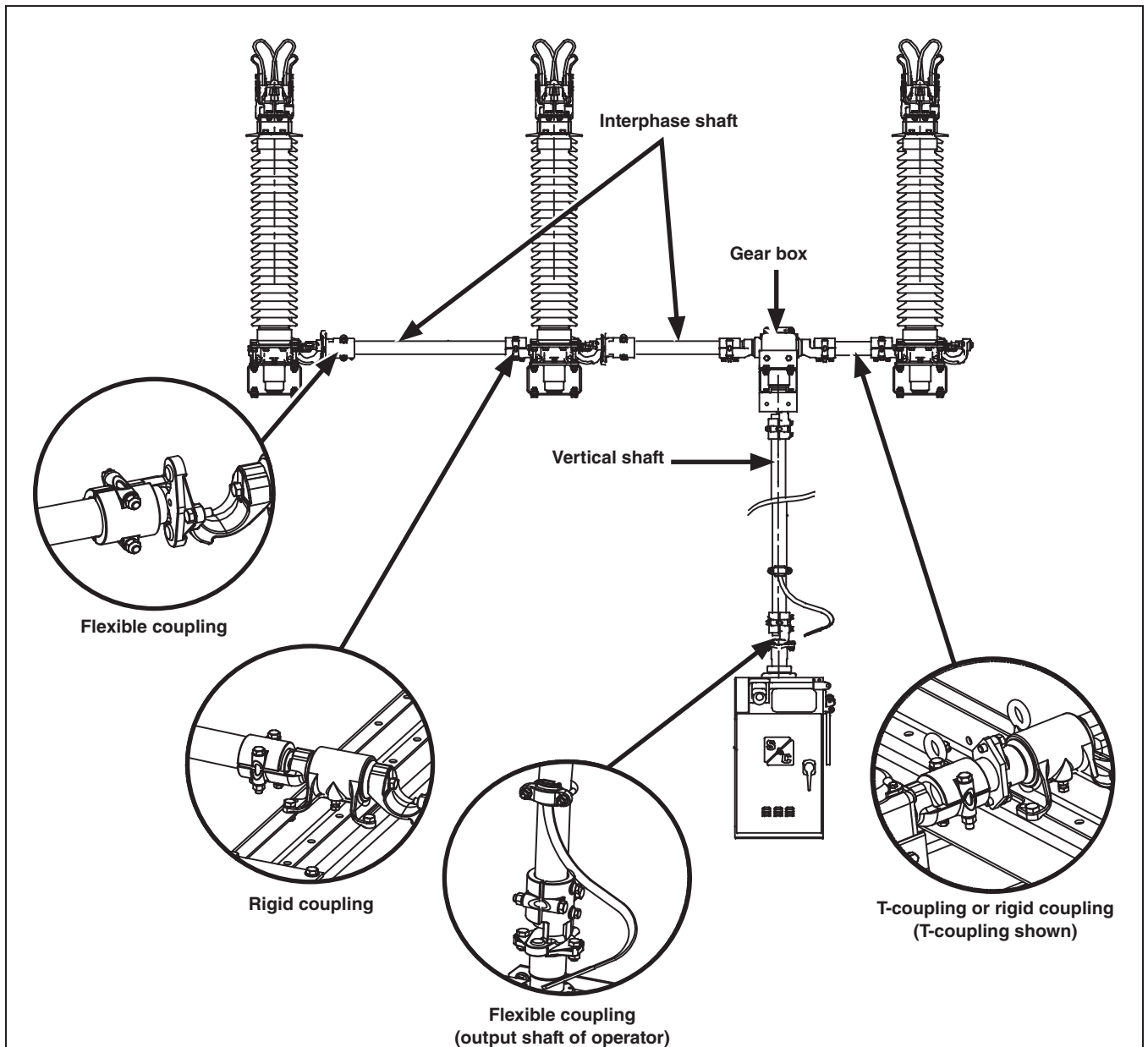

Figure 28. Drive train with coupling detail views.

Installation

- STEP 2.** Attach the flexible coupling plate to the coupling flange on the disconnect using the following procedure:
- Thread the flexible coupling attachment bolts through the flexible coupling plate and through the coupling flange.
 - Tighten the bolts to draw the flexible plate flush against the flange; this will deform the threads in the flexible plate, resulting in a binding, nonslip connection.
 - Install and tighten the self-locking nuts. Do not use lockwashers with the flexible coupling attachment bolts. See Figure 29.

- STEP 3.** Before installing the interphase shaft, make sure the cutting tips of the piercing set screws do not protrude through the clamp.

With all pole-units in the **Closed** position, loosely fit the sections of interphase shaft between the appropriate coupling assemblies. Take care not to bring the switch “out of toggle” when fitting the shaft sections into the couplings. The interphase shaft should extend slightly past the flange end of the clamp. See Figure 30.

NOTICE

The shaft sections are cut to the appropriate length at the factory. **Carefully examine all sections of shaft before cutting any of the shaft sections.** The shaft sections can be trimmed using a pipe cutter.

With the interphase shaft inserted into the coupling, tighten the clamp bolts equally so the clamp pulls down evenly on the coupling.

Tighten the piercing set screws, piercing the shaft, and continue turning until a firm resistance is felt. See Figure 31.

Continue connecting the remaining sections of interphase shaft.

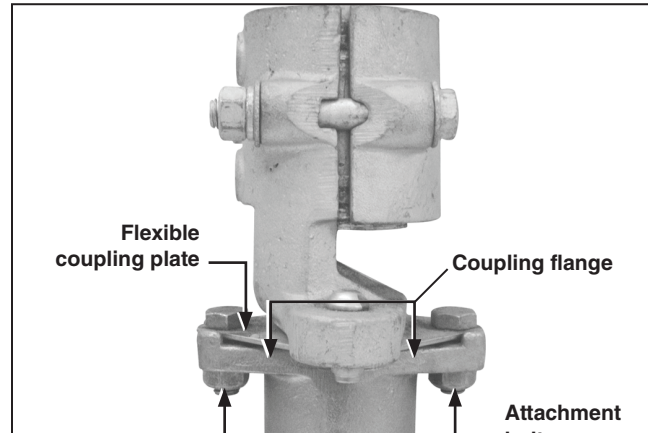

Figure 29. Attach the plate to the coupling flange.

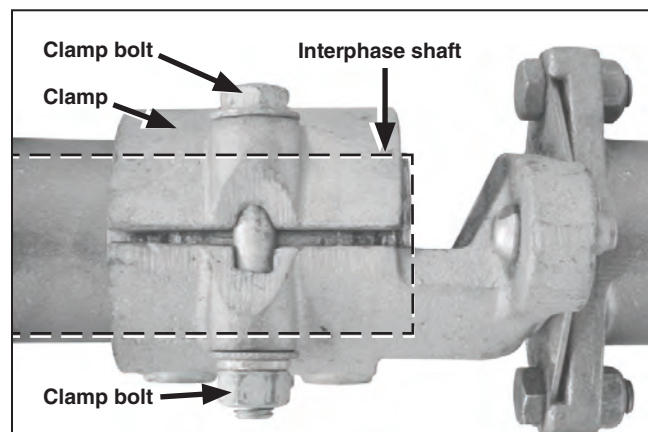

Figure 30. Insert the interphase shaft section between the couplings. Fasten the clamp to the couplings.

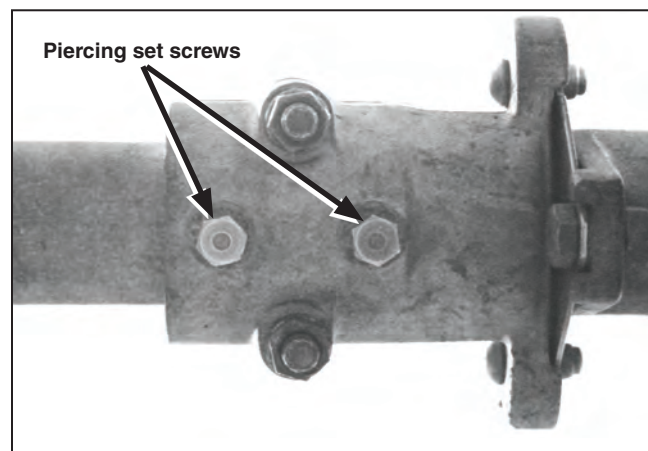

Figure 31. Tighten the piercing set screws.

Installing the Mark VI CS-1A Switch Operator

NOTICE

If more than one Mark VI CS-1A Switch Operator is available at the installation location, be sure to select the one for this particular installation.

Complete the following steps to install the Mark VI CS-1A Switch Operator:

- STEP 1.** Install the upper operator mounting bracket using the following procedure:
- Place a bracket against the pedestal at the appropriate mounting height indicated on the reference drawing.
 - Level the bracket, and draw a pencil mark. Do the same with the bracket on the opposite side of the pedestal.
 - Align the upper operator brackets with the marks and bolt them to the pedestal using two $\frac{5}{8}$ -inch galvanized steel threaded rods, washers, and nuts provided. Tighten the nuts on the threaded rod. See Figure 32.
- STEP 2.** Unbolt the Mark VI CS-1A Switch Operator from its shipping skid. Attach lifting slings around the output shaft of the Mark VI CS-1A Switch Operator. See Figure 33. Lift the operator into place with the operator mounting flange overlapping the operator mounting bracket.
- STEP 3.** Secure the operator flange to the mounting bracket using two $\frac{5}{8}$ -11 \times 2 $\frac{1}{4}$ -inch galvanized steel hex-head cap screws, flat washers, and self-locking hex nuts furnished. See Figure 34. Do not remove the lifting slings.
- STEP 4.** Install the lower operator mounting bracket using the following procedure:
- Align the lower set of operator brackets with the lower flange on the switch operator so the operator flange overlaps the lower mounting bracket. Bolt the brackets to the pedestal using two $\frac{5}{8}$ -inch galvanized steel threaded rods, washers, and self-locking nuts provided. Tighten the nuts on the threaded rod.

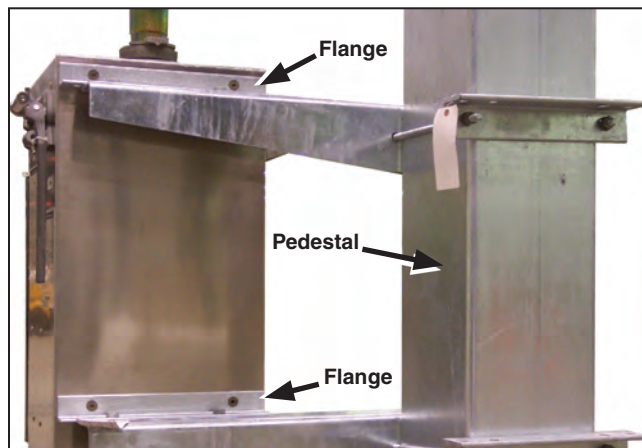

Figure 32. Install the operator mounting brackets.

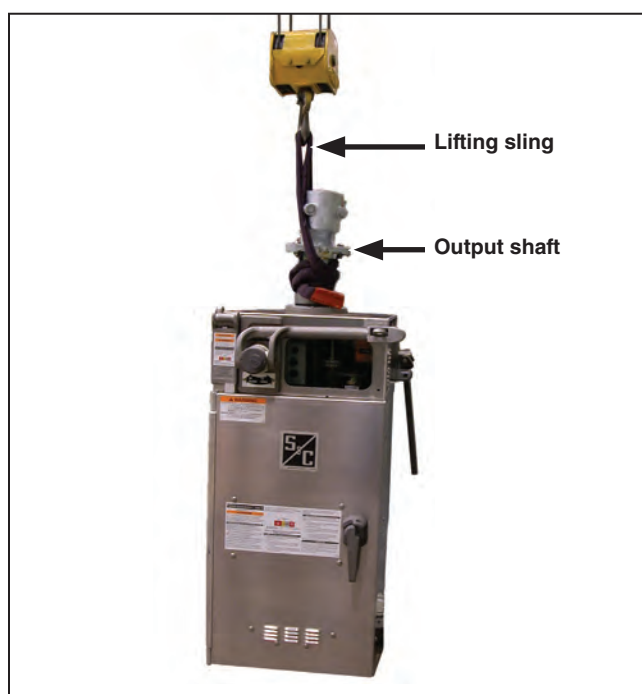

Figure 33. Attach lifting sling to output shaft.

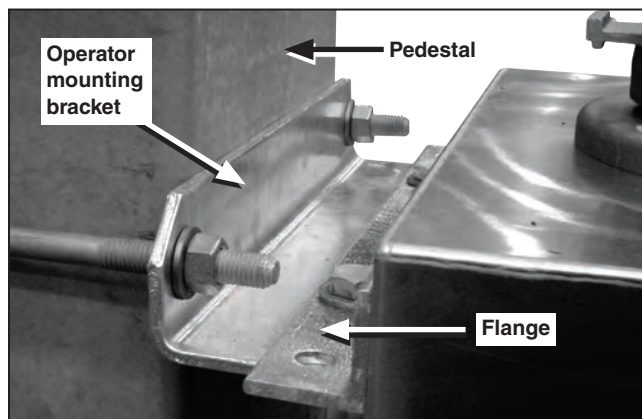

Figure 34. Attach the Mark VI CS-1A Switch Operator flange to the operator mounting brackets.

Installation

- (b) Secure the operator flange to the mounting bracket using two $\frac{5}{8}$ -11 \times 2 $\frac{1}{4}$ -inch galvanized steel hex-head cap screws, flat washers, and self-locking hex nuts.
- (c) Level the brackets. Check the dimension from the base of the pedestal to the lower mounting bracket, as shown on the associated reference drawing (RD). Adjust the height of the switch operator if necessary.

STEP 5. The flexible couplings are pre-installed on the gearbox and Mark VI CS-1A Switch Operator. If required, attach the flexible coupling to the output shaft of the switch operator and to the input coupling of the gearbox using the following procedure:

- (a) Thread the flexible coupling attachment bolts through the flexible coupling plate and through the coupling flange.
- (b) Tighten the bolts to draw the flexible plate flush against the flange; this will deform the threads in the flexible plate, resulting in a binding, nonslip connection.
- (c) Install and tighten the self-locking nuts.
DO NOT use lockwashers with the flexible coupling attachment bolts. See Figure 35.

If universal couplings are specified on the reference drawing instead of flexible couplings, use the same installation procedure.

NOTICE

Make sure the cutting tips of the piercing set screws do not protrude through the body of the flexible coupling on the switch operator output shaft and the flexible coupling attached to the shaft extending from the gearbox.

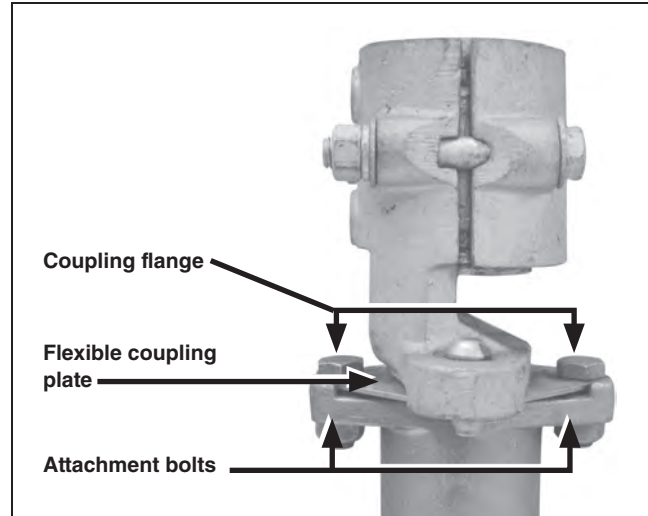

Figure 35. Attach the plate to the output shaft flange.

STEP 6. Before installing the vertical shaft, make sure the cutting tips of the piercing set screws do not protrude through the clamp.

Loosely fit the vertical shaft section between the gearbox and operator coupling assemblies. The vertical shaft should extend slightly past the flange end of each clamp. See Figure 36. If the shaft does not seat correctly, or is too long or short, re-check the mounting height of the Mark VI CS-1A Switch Operator and re-adjust if necessary.

NOTICE

The shaft sections are cut to the appropriate length at the factory. **Carefully examine and measure all sections of shaft before cutting any of the shaft sections.** The shaft sections can be trimmed using a pipe cutter.

STEP 7. With the vertical shaft inserted into the couplings, tighten the clamp bolts equally so the clamp pulls down evenly on the couplings.

When the vertical shaft is seated properly in both the gearbox and operator couplings, tighten the piercing set screws, piercing the shaft and continue turning until a firm resistance is felt. See Figure 37.

STEP 8. Remove the lifting slings from the output shaft of the switch operator.

STEP 9. Fasten the free end of the grounding strap to the vertical shaft a few inches above the flexible coupling attached to the switch operator using the grounding connector provided. Then, fasten the other end of the grounding strap to a suitable earth ground. See Figure 38.

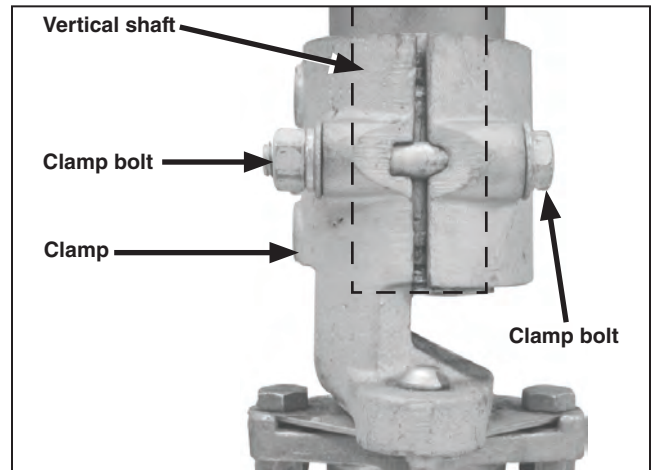

Figure 36. Insert the vertical shaft sections between the couplings. Fasten the clamp to the couplings.

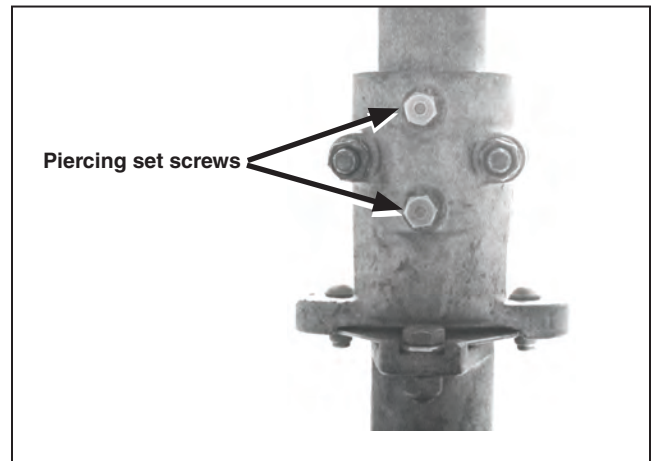

Figure 37. Tighten the piercing set screws.

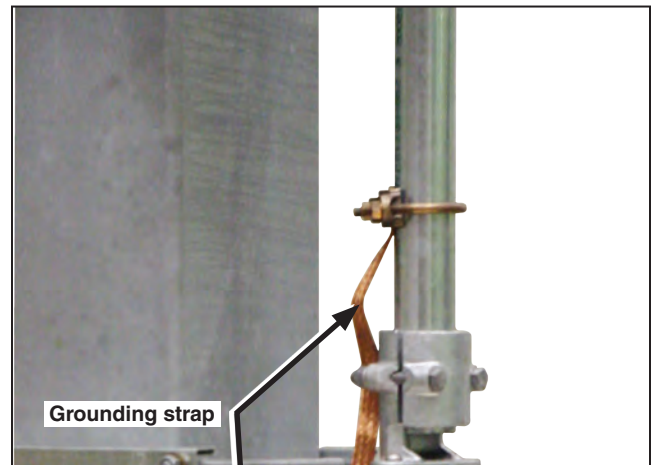

Figure 38. Attach the grounding strap.

Installation

Installing the Interrupter Charging Motors

NOTICE

The charging motors are factory-wired to use 48-Vdc, 125-Vdc, or 115-Vac control voltage. Motor control voltage cannot be changed in the field. Make sure the motors are the correct voltage for the installation.

Repeat Step 1 through Step 3 for each interrupter.

STEP 1. Manually rotate the operating shaft counter-clockwise approximately $\frac{1}{4}$ -turn until it is centered, as shown in Figure 39. The operating pin should be perpendicular to the pole-unit base.

STEP 2. Locate the four $\frac{1}{2}$ -13-inch mounting bosses on the top of the motor. See Figure 39 and Figure 40. Align the mounting bosses with the holes in the motor brackets. Rotate the headhook if necessary.

If the holes do not align, loosen the studs supporting the motor brackets, and shift them until proper alignment is achieved.

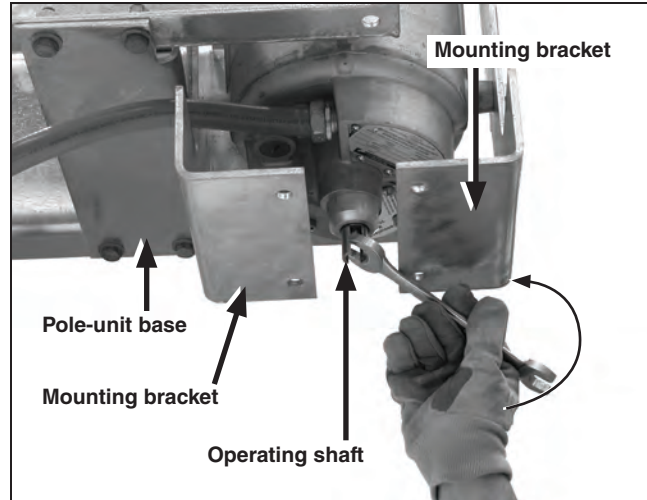

Figure 39. Rotate the operating shaft until it is centered.

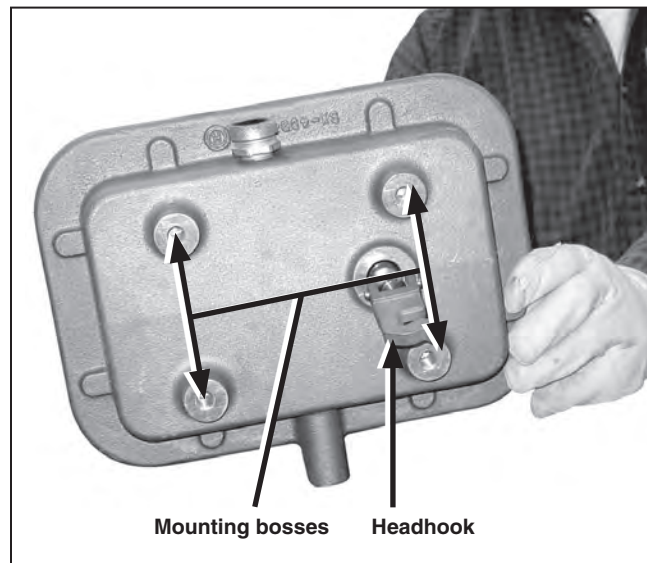

Figure 40. Charging motor mounting bosses.

STEP 3. Hook the headhook onto the operating shaft pin. The headhook should hang securely from the operating shaft. Turn the motor until the mounting bosses align with the holes in the mounting brackets. See Figure 41.

STEP 4. Using the four 1/2-13 x 1/4-inch stainless steel hex-head cap screws and flat washers furnished, fasten the motor to the brackets. Tighten the screws to between 40 and 50 ft.-lbs. See Figure 42.

If engaging the headhook with the operating shaft is difficult, turn the operating shaft counterclockwise until it stops, approximately one to four turns. Then, back the shaft clockwise 1/4-turn. The headhook should engage easily with the operating shaft.

Retighten any of the nuts loosened in Step 2 on page 26.

⚠ WARNING

Never exceed the recommended torque limit. The interrupter base is pressurized to 75 PSI. **Damage to the interrupter and personal injury may occur.**

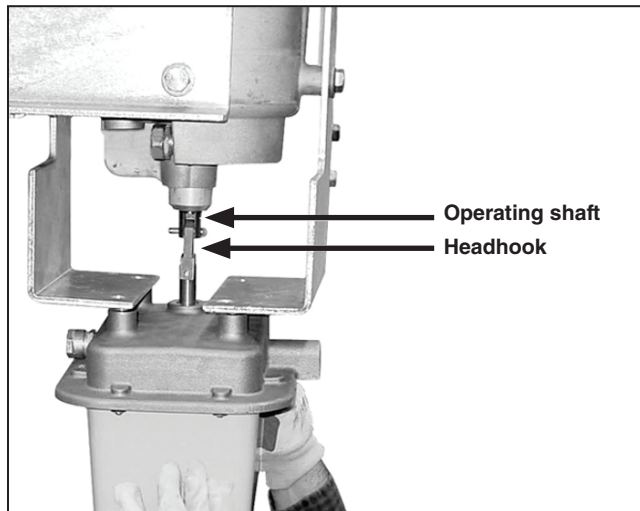

Figure 41. Attach the motor to the operating shaft.

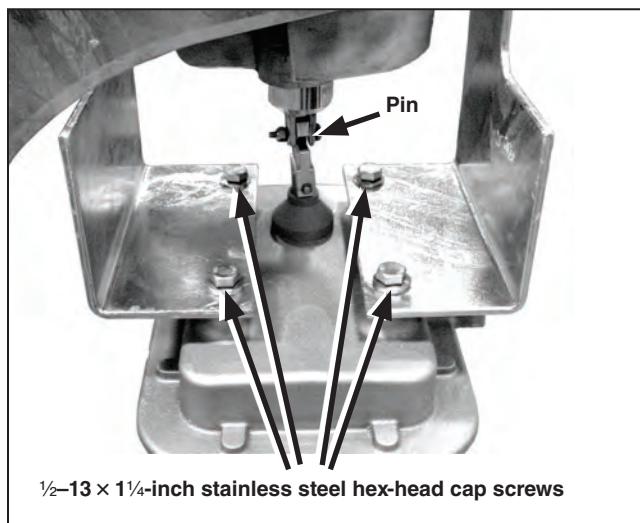

Figure 42. Secure the motor to the motor brackets.

Installation

Installing the Conduit Assembly

NOTICE

Keep conduit and conduit hangers clear of the drive train. Do not attach the conduit assembly to the interphase or vertical operating shaft, and do not attach conduit to any moving parts of the circuit-switcher. Damage to the circuit-switcher can occur.

Complete the following steps to install the conduit:

STEP 1. Two or more conduit support brackets may be required, depending on the height of the pedestals. Refer to the associated reference drawing for support bracket placement. Install the conduit assembly support brackets using the following procedure:

- (a) Insert the conduit clips into the channel in one of the conduit support brackets.
- (b) Place the bracket against the pedestal at the appropriate mounting height indicated on the reference drawing, level it, and mark the position with a pencil. Do the same with the second bracket on the opposite side.
- (c) Align the brackets with the marks, and bolt them to the pedestal with the two $\frac{5}{8}$ -inch threaded rods, square nuts, hex nuts, and washers furnished. Inserting the square nuts inside the same channel as the conduit clip will prevent the nut from rotating during installation. Figure 43.

STEP 2. Install the conduit hangers at the holes in the switch base as shown on the reference drawing. Unscrew the clip fasteners and set aside in a protected area.

STEP 3. Set the conduit assembly in the conduit hangers, and fasten it in place with the hardware reserved from Step 2. The conduit should be attached to the switch base in accordance with the reference drawing, with the conduit directed down the pedestal to the switch operator. See Figure 44.

Position the conduit ends near the interrupter junction boxes and charging motors as shown on the associated wiring diagram.

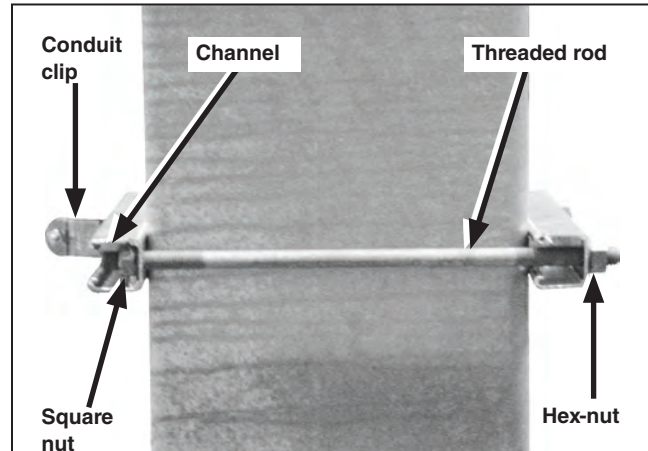

Figure 43. Install the conduit hangers.

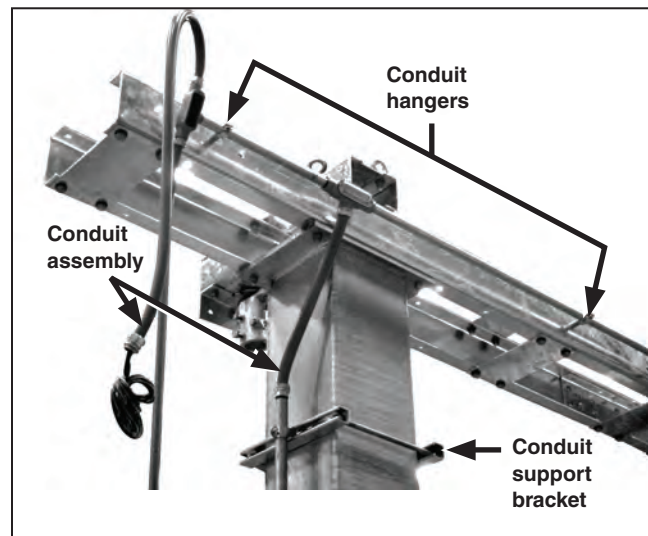

Figure 44. Set the conduit assembly into the conduit hangers and fasten in place. (Pole-units and drive train are not shown.)

Wiring the Interrupters and Charging Motors

Repeat Step 1 through Step 7 for each interrupter and charging motor.

⚠ WARNING

Do not remove the window bolts on the interrupter. The interrupter is pressurized to 75 PSIG. **Serious injury could occur.**

STEP 1. Remove the outer motor support bracket and retain all hardware in a protected area.

Remove the three removable screws of the interrupter electrical junction box cover. Retain the screws. Loosen the fourth retaining screw. Then, swing out the cover to access the wiring inside the electrical junction box. See Figure 45 through Figure 47.

STEP 2. Following the wiring diagram furnished, connect the conduit wiring to the wiring inside the electrical junction box. Use the butt splices supplied with the junction-box wiring. The butt splices accommodate 18 to 22 AWG wire (18 AWG wire is recommended).

NOTICE

To ensure proper crimping of the butt splices, use a Panduit controlled-cycle hand tool (CT-1550) or a similar tool for attaching 18- to 20-gauge insulated ring lugs.

STEP 3. Rotate the cover of the electrical junction box and replace the screws that were removed. Securely tighten all screws. See Figure 46. Then, reinstall the removed motor bracket. Torque all 1/2-inch bolts to 40-50 ft.-lbs. Torque all 5/8-inch studs to 70-80 ft.-lbs.

NOTICE

When inserting the connected wires into the electrical junction box, make sure no wires are pinched underneath the junction box cover. Trim excessive wire length from the interrupter's electrical junction box wiring before installation if necessary.

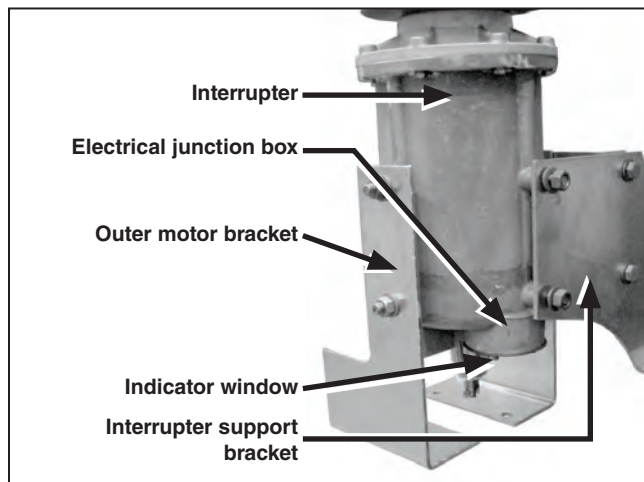

Figure 45. Temporarily remove motor bracket.

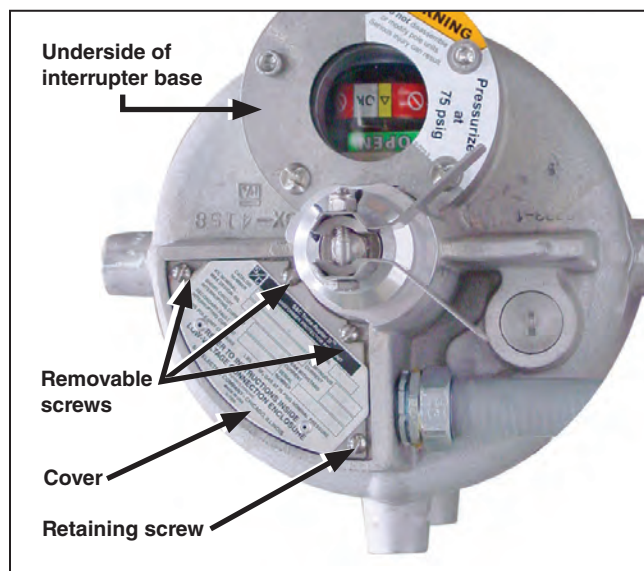

Figure 46. Remove the three removable screws from the interrupter electrical junction box cover. Loosen but do not remove the fourth screw.

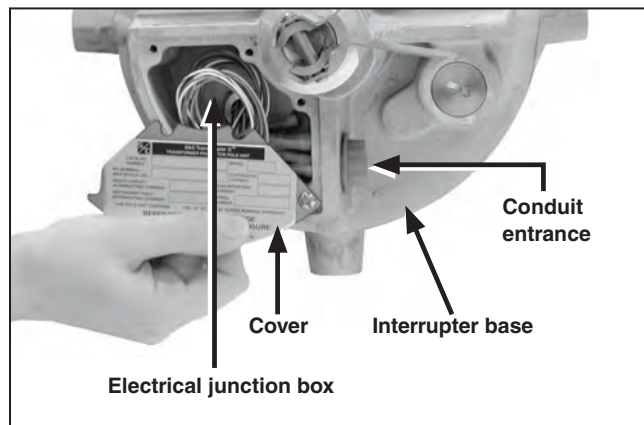

Figure 47. Swing out the cover to access the wiring inside the electrical junction box.

Installation

STEP 4. Remove and retain the eight 10-32 × 5/8-inch stainless steel round-head machine screws securing the motor cover to the motor housing. Remove the motor cover, and set the cover and screws aside in a protected area. See Figure 48.

STEP 5. Connect the conduit to the 1/2-14 NPT tap on the side of the motor housing, and pull the wires through into the motor housing. Use watertight fittings to make all connections. See Figure 49.

STEP 6. Following the supplied wiring diagram, make the necessary wiring connections to the terminal block in the motor operator. See Figure 57. Do not remove the jumper between Terminals 8 and 9.

Train the motor wiring towards the center of the housing so the motor wiring does not come in contact with the motor cover. Bend the terminal lugs if necessary. Then, replace the motor cover and secure it using the 10-32 × 5/8-inch round-head machine screws retained from Step 5.

NOTICE

If control power is lost while the Mark VI Circuit-Switcher interrupter charging motors are closing and charging the interrupters, the jumper between Terminals 8 and 9 will force the motor operators to “reset” to the beginning of their charge cycle when control power is restored.

STEP 7. Replace the motor cover and secure it using the screws retained from Step 4.

NOTICE

Do not connect the wiring from the Mark VI CS-1A Switch Operator at this time. Keep the wiring clear of any moving parts inside the operator.



Figure 48. Remove the motor cover.

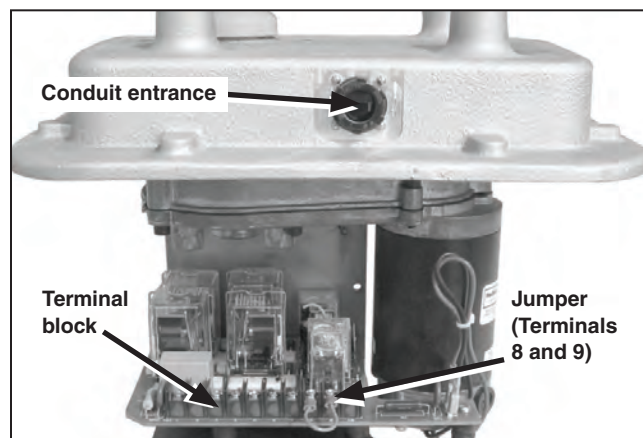

Figure 49. Bring conduit through entrance into the motor housing. Do not remove the jumper.

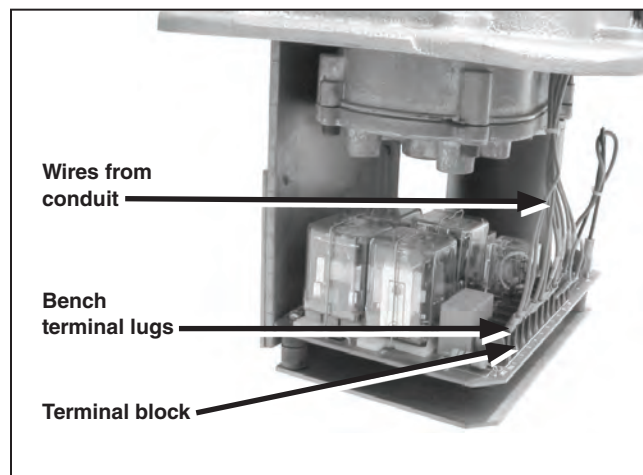

Figure 50. Connect wiring to terminals per the supplied wiring diagram. Train the wires away from the edge of the motor housing to allow clearance between the wires and the motor cover. Bend the terminal wire lugs if necessary.

If the quick-connect option (“C2”) is specified: Plug-style connections will replace the butt-splice connection.

The male plug is keyed to the female socket. See Figure 51. Push the plug into the socket and turn the black ring until the red line around the outside of the socket is obscured. See Figure 52 and Figure 53.

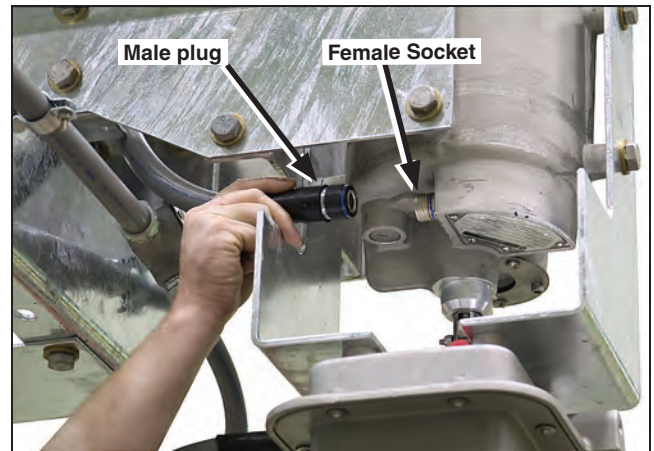

Figure 51. The optional quick-connect control cable. Male plug is keyed into female socket.

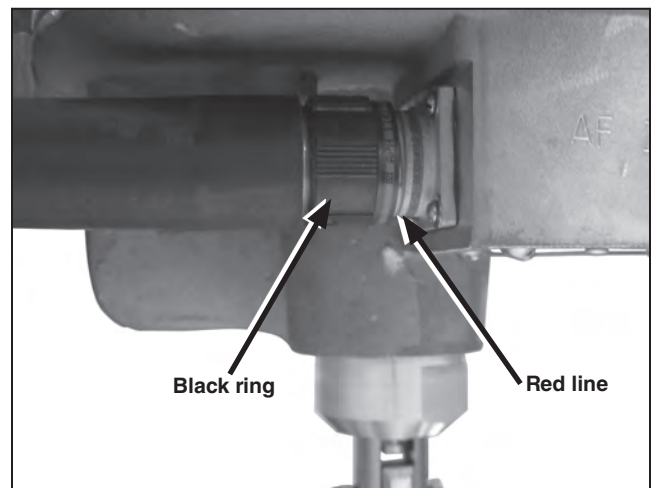

Figure 52. Turn ring until red line is obscured.

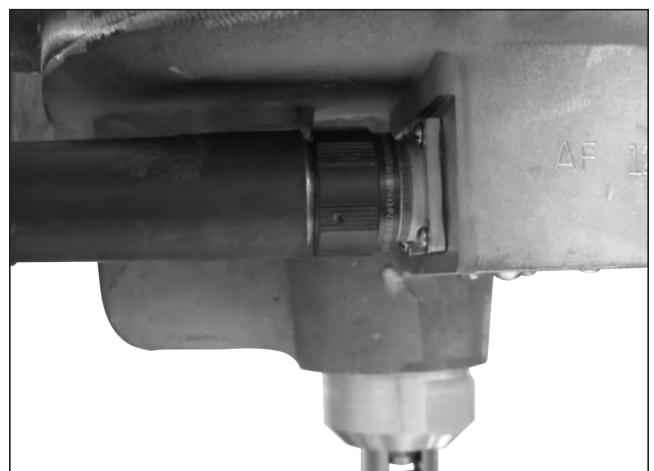

Figure 53. The quick connector fully tightened.

Wiring and Adjusting the Switch Operator

Before Starting

Make sure the Mark VI CS-1A Switch Operator is securely attached to the S&C Mounting Pedestal and the vertical shaft is attached to the coupling on the output shaft of the switch operator.

The factory-installed jumpers should be in place between the interrupter contacts. See Figure 54.

NOTICE

Do not remove the jumpers until directed to do so in the following instructions. Do not wire the interrupters and charging motors to the Mark VI CS-1A Switch Operator until directed to do so in the following instructions.

Two tagged temporary jumpers have been installed inside the Mark VI CS-1A Switch Operator between the interrupter “a” contacts and the “b” contacts. These jumpers bypass the interrupter, allowing for adjustment and checkout of the operator before the interrupters and charging motors are wired into the circuit. (The charging motors take two minutes to close and reset the interrupters between operations.)

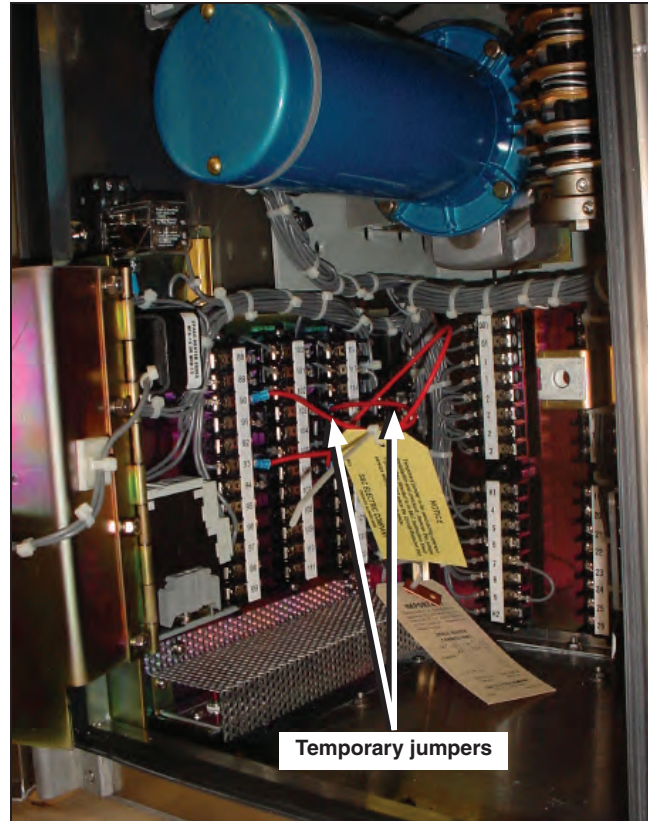

Figure 54. Location of the temporary jumpers.

Connecting Control Power and User-Furnished Control Circuits

Complete the following directions to connect control power and control circuits:

- STEP 1.** Mark the conduit entrance location for the control-circuit and control-power wiring on the conduit-entrance plate at the bottom of the switch operator enclosure. See Figure 55. Remove the conduit-entrance plate and cut out the necessary openings.

Replace the conduit-entrance plate and make up the entrance fittings. Apply the furnished sealing compound when replacing the conduit entrance plate. Verify the conduit entrance fittings are properly sealed to prevent water ingress.

NOTICE

To avoid accidental energizing of the operator after the external connections have been completed, remove the two-pole pull-out fuseholders for the motor and space heater. See Figure 55. **Reinsert the fuseholder only when indicated in the following steps.**

- STEP 2.** Remove the labels and the blocking tape from the motor contactors. See Figure 56.

NOTICE

Do not connect the wiring from the interrupters or interrupter charging motors at this time. Complete the installation and testing of the control circuit wiring before wiring the interrupters and charging motors. The charging motors take approximately two minutes to close and charge the interrupters.

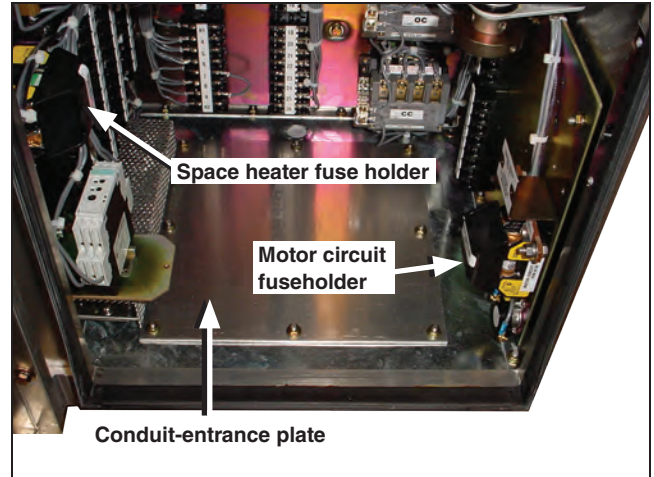

Figure 55. The conduit entrance plate.

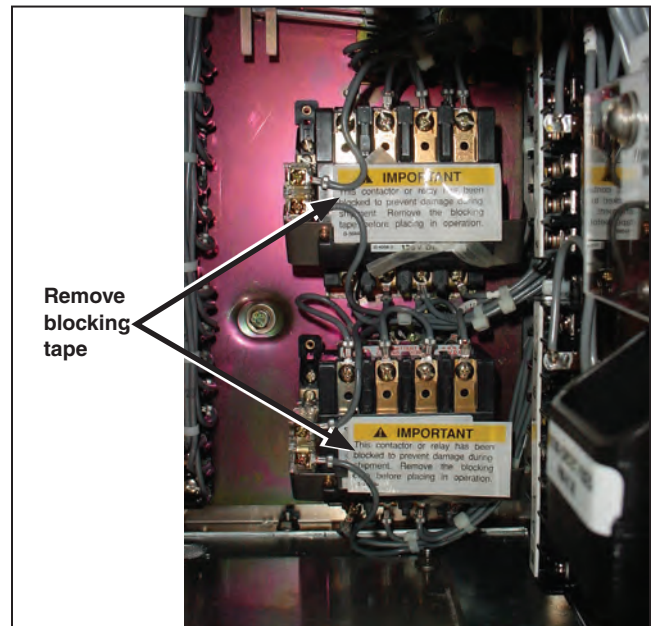

Figure 56. Remove the blocking tape from motor contactors.

Wiring and Adjusting the Switch Operator

STEP 3. Connect the external control-circuit wiring (including space-heater source leads) to the terminal blocks of the switch operator in accordance with the wiring diagram furnished. See Figure 57.

CAUTION

Unauthorized changes should not be made in the wiring of this switch operator. Should a control-circuit revision appear desirable, it should be made only on the authority of a revised wiring diagram approved by both the user and S&C Electric Company. Incorrect wiring can cause damage to the operator and may cause minor electrical shock.

NOTICE

Observe recommended minimum wire-size requirements for the control-circuit wiring, as shown in Information Bulletin 712-60 and on the switch operator schematic wiring diagram furnished. Wiring must be complete, and adequate control voltage must be available at the switch operator before checkout.

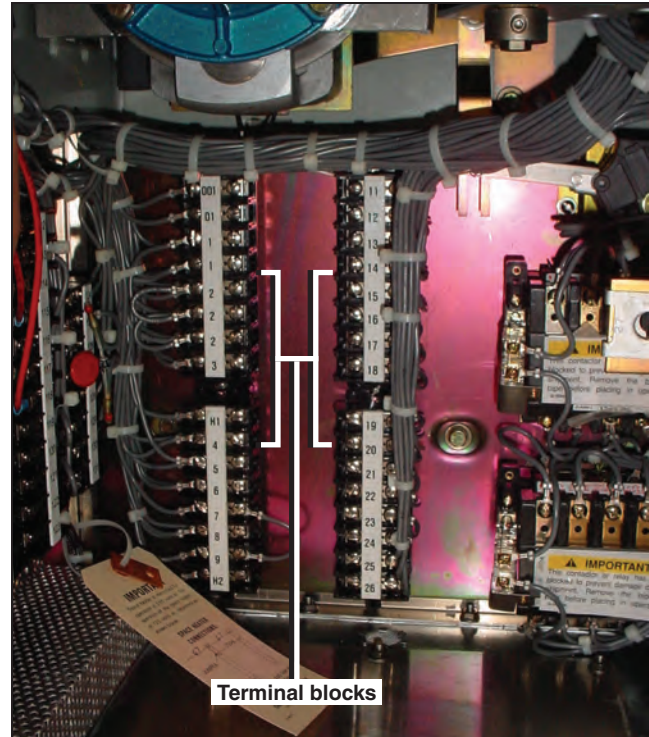

Figure 57. Connect the external wiring to the terminal blocks.

Using the Manual Operating Handle

Before proceeding further, become familiar with the operation of the MANUAL OPERATING handle.

WARNING

Do not operate the Mark VI Circuit-Switcher with the MANUAL OPERATING handle when the switch is energized. The MANUAL OPERATING handle should only be used during installation and checkout of the switch. **Manual operation of an energized Mark VI Circuit-Switcher could, in the event of a fault or loss of control power to the operator, cause serious injury or death as well as damage to the circuit-switcher.**

Note: The MANUAL OPERATING handle should only be used during installation, checkout, and inspection of the circuit-switcher.

NOTICE

The MANUAL OPERATING handle may be disengaged from the switch operator mechanism in any position. The handle may be padlocked in its **Storage** position.

To operate:

- STEP 1.** Pull the latch knob on the hub of the MANUAL OPERATING handle and pivot the handle forward slightly from its **Storage** position.
- STEP 2.** Release the latch knob while continuing to pivot the handle forward to lock it into the **Cranking** position. See Figure 58. (As the handle is pivoted forward, the motor brake is mechanically released, both leads of the control source are automatically disconnected, and both the opening and closing motor contactors are mechanically blocked in the **Open** position.)
- STEP 3.** The disconnect can be opened and closed by cranking the handle clockwise or counterclockwise respectively.

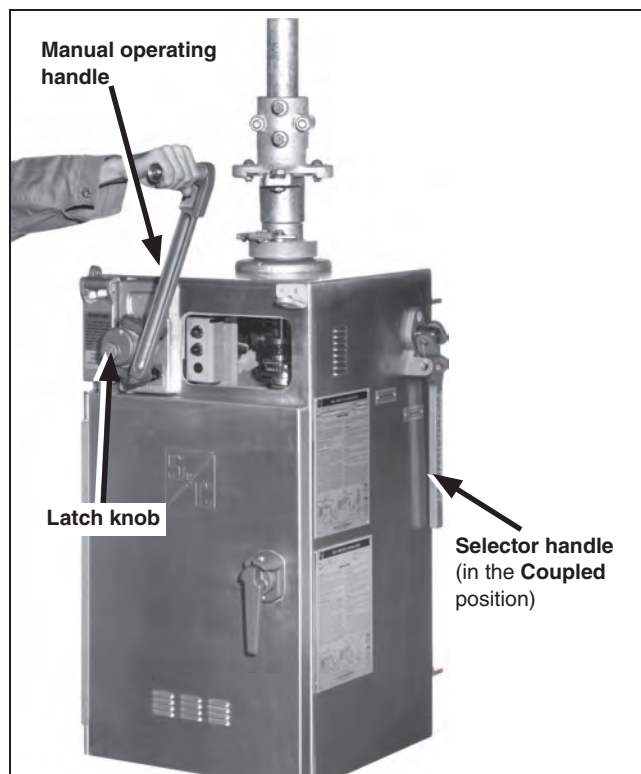

Figure 58. Manually operating the disconnect with the MANUAL OPERATING handle.

Wiring and Adjusting the Switch Operator

To return the **MANUAL OPERATING handle to its Storage position**

- STEP 1.** Pull the latch knob and pivot the handle approximately 90°. The handle will disengage from the switch operator and may be rotated freely in either direction.
- STEP 2.** Complete handle storage by pivoting the operating handle backward approximately 90° until it latches in the **Storage** position.

Using the Selector Handle (Coupling and Decoupling)

The **SELECTOR** handle is used to couple and decouple the motor from the operating shaft. Decoupling the motor allows the user to install and configure control schemes and check operation of the motor without opening and closing the disconnect.

The **SELECTOR** handle is located on the right-hand side of the switch operator enclosure. See Figure 58 on page 35.

To decouple:

- STEP 1.** Swing the **SELECTOR** handle upright and slowly rotate it clockwise 50° to the **Decoupled** position. See Figure 59.
- STEP 2.** Lower the **SELECTOR** handle to engage the locking tab.
- Note:** The switch operator now may be operated either manually or electrically without operating the disconnect. The switch operator output shaft is prevented from moving by a mechanical locking device located within the switch operator enclosure. During the intermediate segment of the **SELECTOR** handle travel, which includes the position at which actual disengagement (or engagement) of the internal decoupling mechanism occurs, the motor-circuit source leads are momentarily disconnected and both the opening and closing motor contactors are mechanically blocked in the **Open** position.
- STEP 3.** Look through the observation window and verify the internal decoupling mechanism is in the **Decoupled** position. See Figure 60.

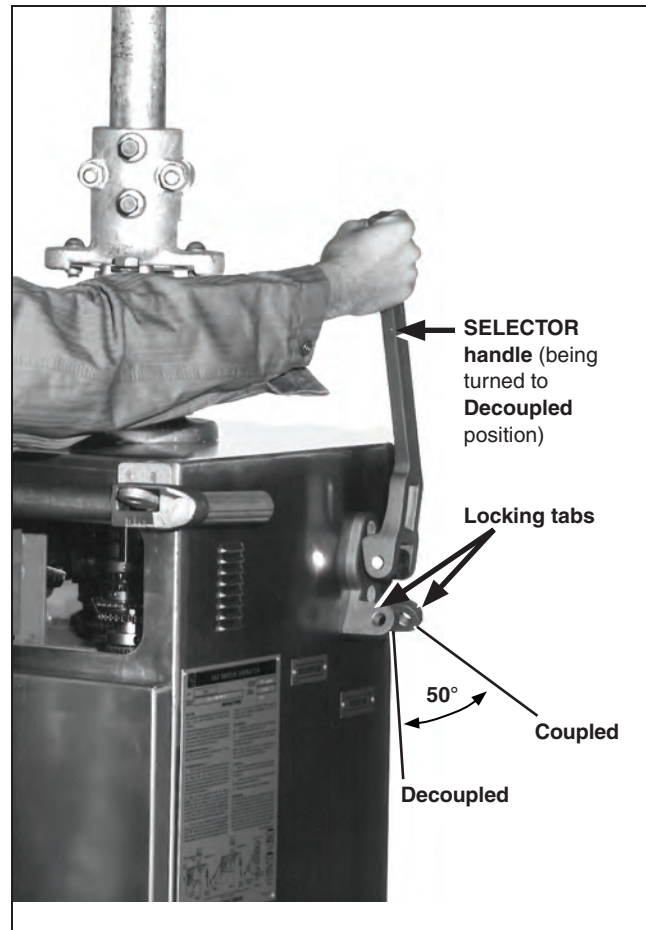

Figure 59. Selector handle operation.

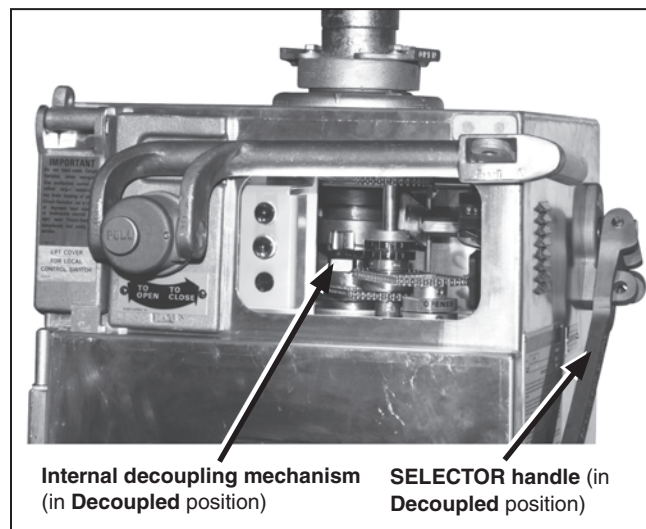

Figure 60. Verify the switch is Decoupled.

To couple:

- STEP 1.** Manually operate the MANUAL OPERATING handle to bring the disconnect to the same position (**Open** or **Closed**) as the Mark VI CS-1A Switch Operator. The switch operator position indicator, seen through the observation window, will show when the approximate **Open** or **Closed** position has been attained. (The position indicator for the disconnect, located on the output-shaft collar of the switch operator, will be aligned later.)
- STEP 2.** Turn the MANUAL OPERATING handle slowly until the position-indexing drums are numerically aligned.
- STEP 3.** Swing the SELECTOR handle upright and rotate it counterclockwise to the **Coupled** position.
- STEP 4.** Lower the handle to engage the locking tab. Verify the switch is **Coupled**. See Figure 61.

NOTICE

The SELECTOR handle may be padlocked in either position.

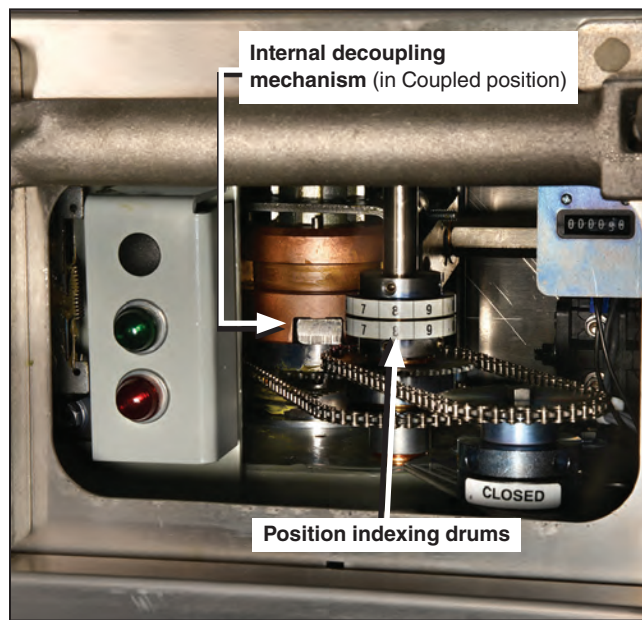

Figure 61. Verify the switch is Coupled.

Adjusting the Switch Operator

NOTICE

To avoid accidentally energizing the operator, remove the two-pole pull-out fuseholders for the motor and space heater and do not reinsert them until so directed.

Complete the following steps to adjust the switch operator:

- STEP 1.** Manually operate the disconnect to bring it to the same position (fully **Open** or fully **Closed**) as the Mark VI CS-1A Switch Operator.
- STEP 2.** Tighten the flexible coupling clamp bolts on the output shaft of the operator equally so the clamp pulls down evenly. Then, tighten the associated piercing set screws, piercing the shaft, and continue tuning until a firm resistance is felt. See Figure 62.
- STEP 3.** With the SELECTOR handle in the **Coupled** position, crank the disconnect to the fully **Open** position and then accurately align the disconnect position indicators on the output-shaft collar of the switch operator with the alignment arrow below. See Figure 63.
- STEP 4.** Make sure the drive-shaft crank of each pole-unit is in an **Overtoggle** position and against its Open or Closed stop at the fully **Open** or fully **Closed** position of the switch operator.

CAUTION

Avoid forcing the power train beyond the fully **Open** or fully **Closed** stop positions. Forced cranking against these stops can build up sufficient spring energy in the vertical and interphase shafts to cause the MANUAL OPERATING handle to spin backwards if the grasp on the handle is accidentally released, causing minor injury.

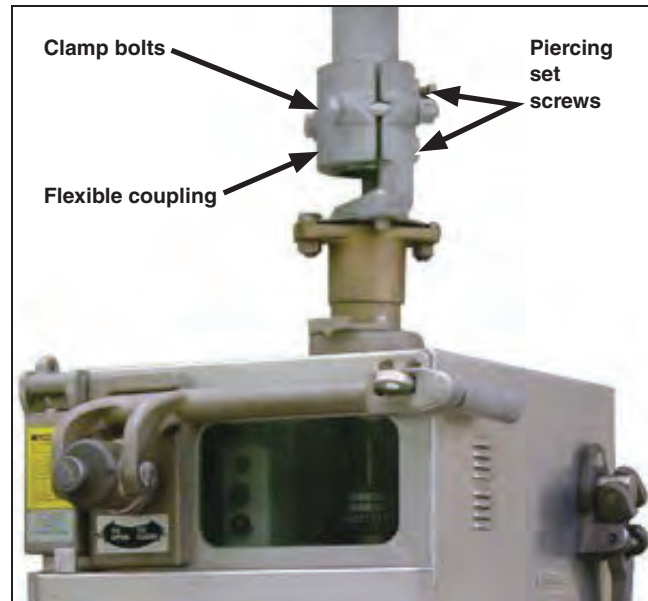

Figure 62. Tighten flexible coupling on operator output shaft. Tighten piercing set screws.

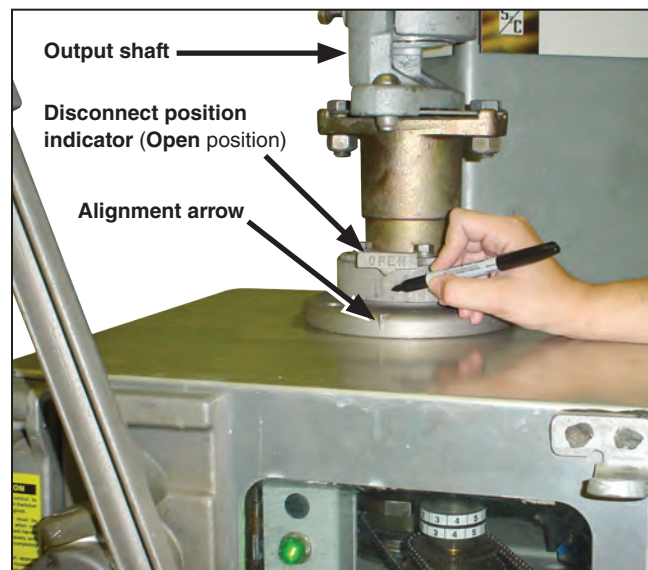

Figure 63. Adjust the position indicator.

STEP 5. Verify the directions of rotation are correct as follows:

- (a) With the SELECTOR handle in the **Coupled** position, manually crank the disconnect to the fully **Open** position and then to the fully **Closed** position. Temporarily mark, on the top of the switch operator enclosure, the direction in which the output shaft rotates to close the disconnect. See Figure 63 on page 38.
- (b) If the cranking direction required to close the disconnect is opposite to that indicated on the arrow plate, remove the arrow-plate mounting screws and remount the arrow plate, exposing the other side. See Figure 64.
- (c) With the MANUAL OPERATING handle in its **Storage** position and the SELECTOR handle in the **Decoupled** position, reinsert the motor-circuit fuseholder. Open the pushbutton protective cover● and operate the switch operator by means of the externally mounted OPEN/CLOSE push-buttons, if provided, or in their absence by momentarily jumpering Terminals 1 and 8 to open and 1 and 9 to close.

NOTICE

Terminal designations may differ in special wiring diagrams. In such cases, refer to the specific wiring diagram for correct terminal designations.

- (d) Make note of the direction in which the travel-limit discs rotate when the switch operator closes. The direction should agree with the temporary direction mark on the top of the enclosure and the direction displayed in the cutaway section on the outer ring of the travel-limit discs. See Figure 65 and Figure 66 on page 40.

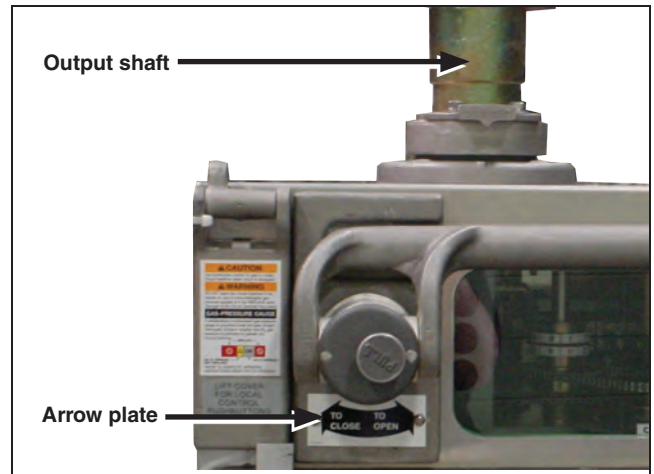

Figure 64. Verify the direction of the output shaft rotation matches the direction indicated by the arrow plate.

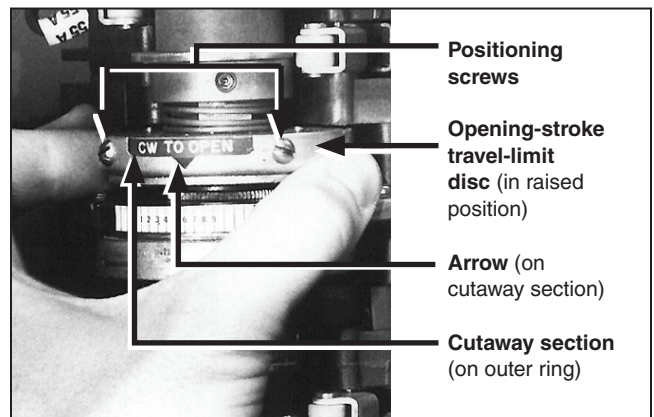

Figure 65. Make sure the cutaway section indicates the correct direction of rotation (Opening-stroke disc).

● For a switch operator with optional remote-control blocking switch (catalog number suffix “-Y”), opening the pushbutton protective cover prevents remote operation of the switch operator.

Wiring and Adjusting the Switch Operator

- STEP 6.** Verify direction of rotation of the travel-limit discs is the same as the direction of rotation of the output shaft:

NOTICE

The cranking direction to close the disconnect is indicated by an arrow plate located near the hub of the MANUAL OPERATING handle and is set at the factory. **Do not attempt to adjust the motor direction or cranking direction without first consulting S&C Electric Company.**

- (a) ***If the direction of rotation of the travel-limit discs noted in Step 5 on page 39 is opposite to the temporary direction mark, reversal of motor direction will be necessary:*** Remove the motor-circuit fuseholder to avoid accidentally energizing the control circuit. Interchange the “-S1” and “-S2” motor leads connected to terminals 4 and 5.

Reversal of motor direction reverses only the direction of the rotation of the output shaft and travel-limit discs. The identity of the opening-stroke and closing-stroke travel-limit discs (which will be adjusted later) is unaffected.

If the direction of rotation of the travel-limit discs noted in Step 5 on page 39 is opposite to the direction displayed in the cutaway section on the outer ring of the closing-stroke travel-limit disc: Remove the positioning screws on the outer ring of the closing-stroke travel-limit disc. See Figure 66. Rotate the outer ring until the desired direction is displayed in the cutaway section. Replace the positioning screws.

- (b) Reinsert the motor-circuit fuseholder and electrically operate the switch operator to the **Open** position.

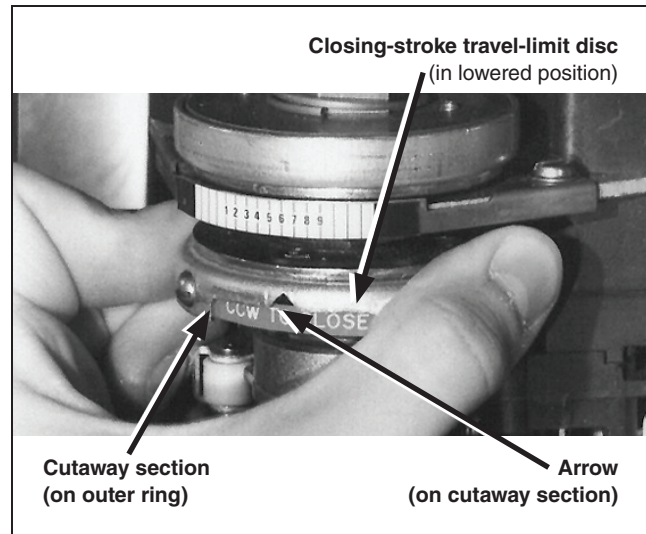

Figure 66. Make sure the cutaway section indicates the correct direction of rotation (Closing-stroke disc).

- (c) *If the direction of output-shaft rotation to open the disconnect is opposite to that displayed in the cutaway section on the outer ring of the opening-stroke travel-limit disc:*
Remove the positioning screws on the outer ring of the opening-stroke travel-limit disc. See Figure 65 on page 39. Rotate the outer ring until the desired direction is displayed in the cutaway section. Replace the positioning screws.

STEP 7. The travel-limit switch governs the extent of output-shaft rotation in the opening and closing directions. It includes six contacts operated by cam-actuated rollers. Positioning of the cams to properly engage the rollers is facilitated by the travel-limit discs (the upper one is the opening-stroke travel-limit disc; the lower one is the closing-stroke travel-limit disc).

Adjust the opening-stroke travel-limit switch as follows:

- Remove the motor-circuit fuseholder.
- Place the SELECTOR handle in the **Coupled** position and manually crank the disconnect to the **Open** position.

- Determine the opening-stroke adjustment indicator-plate number for the travel-limit disc from Table 1.
- Grasp the handwheel and turn it to the extent possible in the direction opposite to the direction the output shaft rotates to open the disconnect. See Figure 67.
- With the handwheel held in the position indicated above, raise the opening-stroke travel-limit disc approximately $\frac{3}{16}$ -inch (5 mm) and rotate the disc until the arrow on its outer ring is aligned with the number on the indicator plate as shown in Table 1. Lower the disc, make sure it is engaged, and release the handwheel.

Table 1. Initial Adjustment of Travel-Limit Discs

Indicator Plate Number			
Opening-Stroke Adjustment		Closing-Stroke Adjustment	
Clockwise to Open	Counterclockwise to Open	Clockwise to Close	Counterclockwise to Close
5	5	5	5

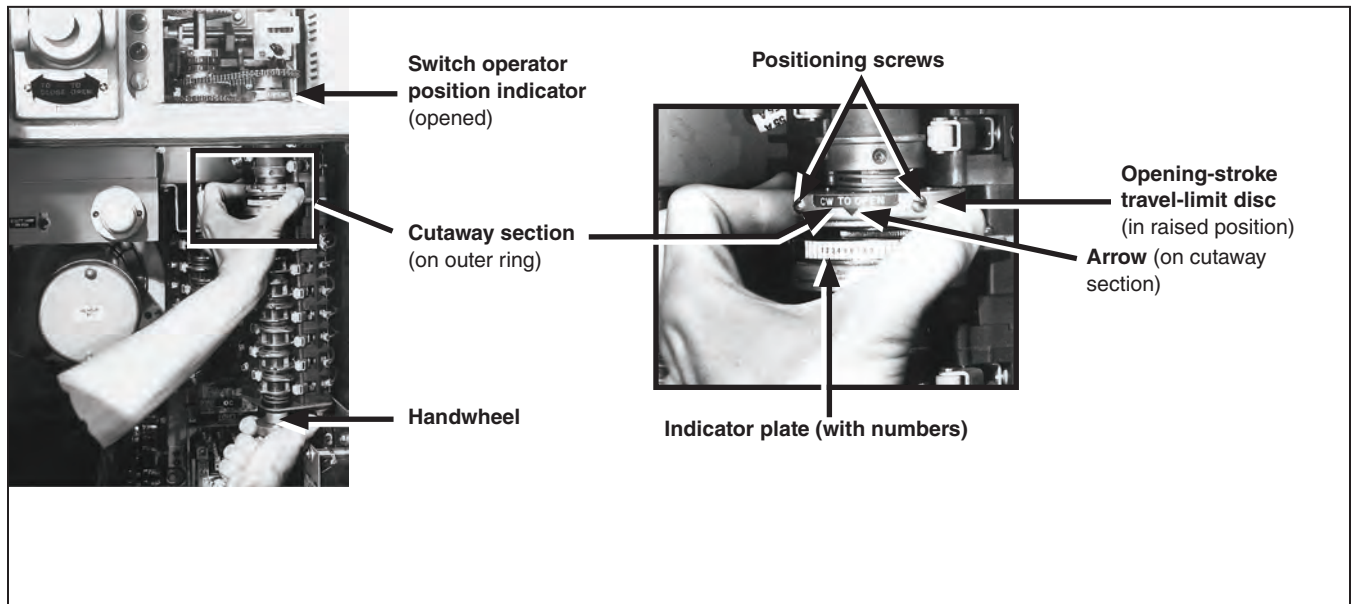

Figure 67. Adjustment of opening-stroke travel-limit disc.

Wiring and Adjusting the Switch Operator

- STEP 8.** Adjust the closing-stroke travel-limit disc (and the associated cams) as follows:
- Manually crank the disconnect to the fully **Closed** position.
 - Grasp the handwheel and turn it to the extent possible in the direction opposite to the direction the output shaft rotates to close disconnect. See Figure 68.
 - With the handwheel held in the position indicated above, lower the closing-stroke travel-limit disc approximately $\frac{3}{16}$ -inch (5 mm) and rotate the disc until the arrow on the outer ring is aligned with the number 5 on the indicator plate. Raise the disc, make sure it is engaged, and release the handwheel.

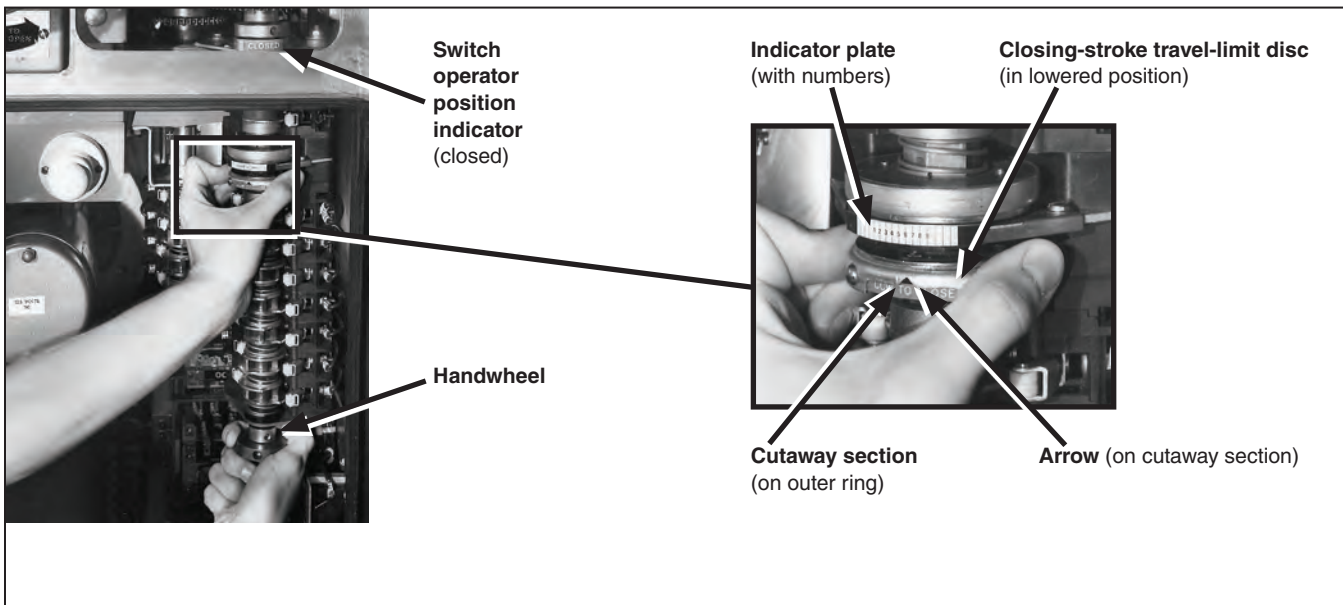

Figure 68. Adjustment of closing-stroke travel-limit disc.

- STEP 9.** After adjusting the travel-limit discs, check the following:
- Place the SELECTOR handle in the **Decoupled** position.
 - Return the MANUAL OPERATING handle to its **Storage** position.
 - Reinsert the motor-circuit fuseholder.
 - Operate the switch operator electrically to open and to close the disconnect. Verify the rotation direction of the travel-limit discs for opening and closing corresponds with the direction of rotation of the output shaft and these directions agree with the direction displayed in the cutaway section on the outer ring of the travel-limit discs.

NOTICE

When the switch operator is operated in the **Decoupled** or “no load” position, the travel-limit discs do not stop at the indicator-plate positions for which they were set in Step 7 on page 41 and Step 8 on page 42. This may be disregarded.

- STEP 10.** There should always be some “unwind” or relaxation of the output shaft (in both the Open and **Closed** positions) indicating the disconnect has been driven to a **Positive-toggle** position against its Open (or Closed) stops.

Check the amount of unwind in the output shaft:

- Place the SELECTOR handle in the **Coupled** position. Operate the Mark VI CS-1A Switch Operator electrically to open the circuit-switcher and determine the amount of overtravel in the opening direction by releasing the motor brake and noting how far the output shaft “unwinds.”
- Release the motor brake by unlatching the MANUAL OPERATING handle and pivoting it rapidly, with a snap motion, toward its **Cranking** position. Then, return the MANUAL OPERATING handle to its **Storage** position.

There should always be some “unwind” or relaxation of the output shaft (in both the **Open** and **Closed** positions) to indicate the circuit-switcher has been driven to a **Positive-toggle** position against its Open (or Closed) stops.

If adjustment is needed:

- (a) Remove the motor-circuit fuseholder.
- (b) Increase the amount of “unwind” by decreasing the opening-stroke travel-limit disc (to increase travel) one indicator-plate number at a time. See Figure 69.

Note: The direction of disc rotation is always the same as the output shaft. The output shaft should never have sufficient “unwind” to cause rotation of the travel-limit discs.

- (c) If rotation of the travel-limit disc is evident, advance the opening-stroke travel-limit disc (to decrease travel) an amount necessary only to eliminate the “unwind” rotation of the travel-limit disc.

NOTICE

Before checking the “unwind” after a closing stroke, remove the motor-circuit fuseholder before releasing the motor brake. Excessive “unwind” at this point could cause rotation of the travel-limit switch sufficient to pick up a “bb” contact, which, in turn, would cause the switch operator to open (if energized).

- (d) With the MANUAL OPERATING handle in its **Storage** position, reinsert the motor-circuit fuseholder and operate the switch operator electrically to close the disconnect.
- (e) Repeat the procedure and adjust the closing-stroke travel-limit disc one indicator-plate number at a time to obtain the correct amount of overtravel in the closing direction.

When the direction of the output shaft and travel-limit disc rotation is clockwise to open:

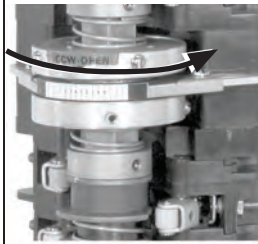

Opening-stroke travel-limit (with disconnect and switch operator in fully **Open** position—raise and turn **counterclockwise** to increase travel of switch operator)



Closing-stroke travel-limit (with disconnect and switch operator in fully **Closed** position—lower and turn **clockwise** to increase travel of switch operator)

When the direction of the output shaft and travel-limit disc rotation is counterclockwise to open:

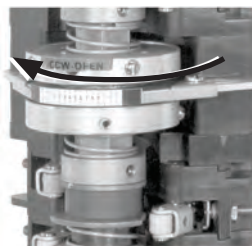

Opening-stroke travel-limit (with disconnect and switch operator in fully **Open** position—raise and turn **clockwise** to increase travel of switch operator)

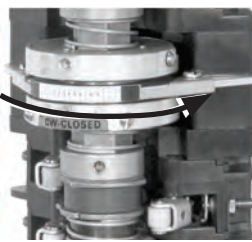

Closing-stroke travel-limit (with disconnect and switch operator in fully **Closed** position—lower and turn **counterclockwise** to increase travel of switch operator)

Figure 69. Adjustment of travel-limit discs for desired “unwind” of output shaft.

STEP 11. Check the operation of the disconnect by operating the switch operator several times to observe the action. Operation should appear smooth, with the disconnect drive-shaft cranks coming to rest firmly against their stops, in an **Overtoggle** position, in both opening and closing directions.

If necessary, realign the disconnect position indicators on the switch operator output-shaft collar with the alignment arrow. See Figure 70.

With the switch operator in the fully **Open** position and then in the fully **Closed** position, check the corresponding switch-operator position indicator. In each position, the corresponding position indicator should be readily visible from the front of the enclosure.

If adjustment of either position indicator is necessary: Remove the motor-circuit fuseholder, loosen the two set screws, and rotate the indicator to the desired position. Retighten set screws. See Figure 70.

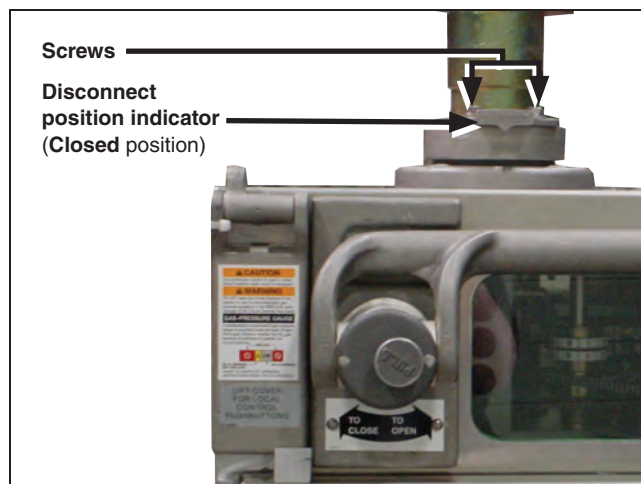

Figure 70. Align position indicator arrow.

Wiring and Adjusting the Switch Operator

STEP 12. The auxiliary switch, which is permanently coupled to the motor, includes eight contacts, Terminals 11 through 26. (If the optional position-indicating lamps are included, six contacts are available: Terminals 13 through 18, and Terminals 21 through 26.) These contacts permit external circuits to be established to monitor switching operations.

A cam-actuated roller operates each contact. The cams are individually adjustable in 4.5-degree increments and can be positioned so roller engagement occurs at the desired point in the operating cycle.

The “standard” configuration for the auxiliary switch consists of four “a1” contacts, Terminals 11 through 18, and four “b1” contacts, Terminals 19 through 26. With the switch operator in the **Open** position, the “a1” contacts are open and the “b1” contacts are closed. With the switch operator in the **Closed** position, the “a1” contacts are closed and the “b1” contacts are open. A contact is closed if its roller is disengaged from a cam and open if its roller is engaged by a cam. See Figure 71 and Figure 72.

Any auxiliary-switch contact being used must be checked for proper operation after the switch operator travel-limit discs have been adjusted. Check the auxiliary-switch contacts for both **Open** and **Closed** positions of the switch operator.

To adjust the auxiliary-switch contacts, refer to Figure 72 and Figure 73 on page 47 and proceed as follows:

- (a) With the SELECTOR handle in the **Coupled** position, operate the switch operator to the fully **Closed** position.
- (b) Remove the motor-circuit fuseholder.
- (c) Determine which “a1” contacts are not in the **Closed** position. A contact is closed if its roller is disengaged from a cam and is open if its roller is engaged by a cam.

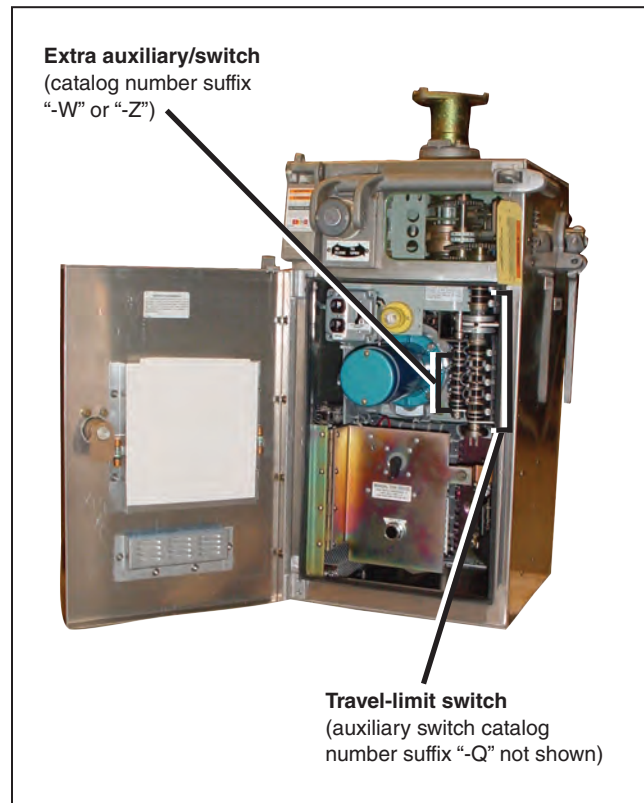

Figure 71. Open front view of switch operator “standard” contact configurations.

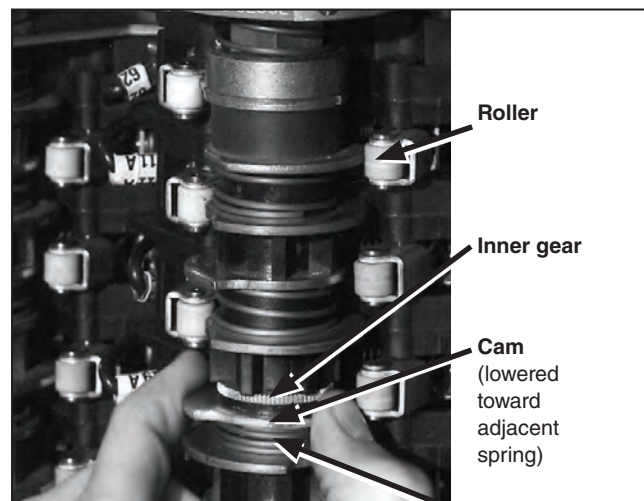

Figure 72. Adjustment of cams on the auxiliary switch.

- (d) For “a1” contacts not in the **Closed** position, raise (or lower) the corresponding cam toward its adjacent spring until the cam is separated from the teeth of the inner gear. Rotate the cam so when lowered (or raised) it will be disengaged from the roller. Lower (or raise) the cam, making sure the teeth mesh with the inner gear and the cam is disengaged from the roller.
- (e) Reinsert the motor-circuit fuseholder.
- (f) Operate the switch operator to the fully **Open** position. Remove the motor-circuit fuseholder and, if necessary, adjust the cams as described in (d) until all “b1” contacts are in the **Closed** position.
- (g) Reinsert the motor-circuit fuseholder and operate the disconnect. Both sets of contacts should now be correctly positioned for both the **Open** and **Closed** positions of the disconnect. Sufficient adjustment is available to provide correct positioning of both sets of contacts.

Because each cam can be individually adjusted in 4.5-degree increments, any “a1” contact can be changed to a “b1” contact, and vice-versa. Because of the many positions to which the cams can be adjusted, various rollers can be engaged or disengaged to open or close their contacts—simultaneously, sequentially, randomly, or in various combinations.

Adjustment of the auxiliary switch for other than the “standard” contact configuration is left to the user. The motor-circuit fuseholder should be removed when adjusting these contacts. (Switch operators furnished with the suffix “-Q” option are equipped with an extra auxiliary switch, Terminals 27 through 34, having four contacts—two “a1” and two “b1”—that may be adjusted as described in (a) through (g).

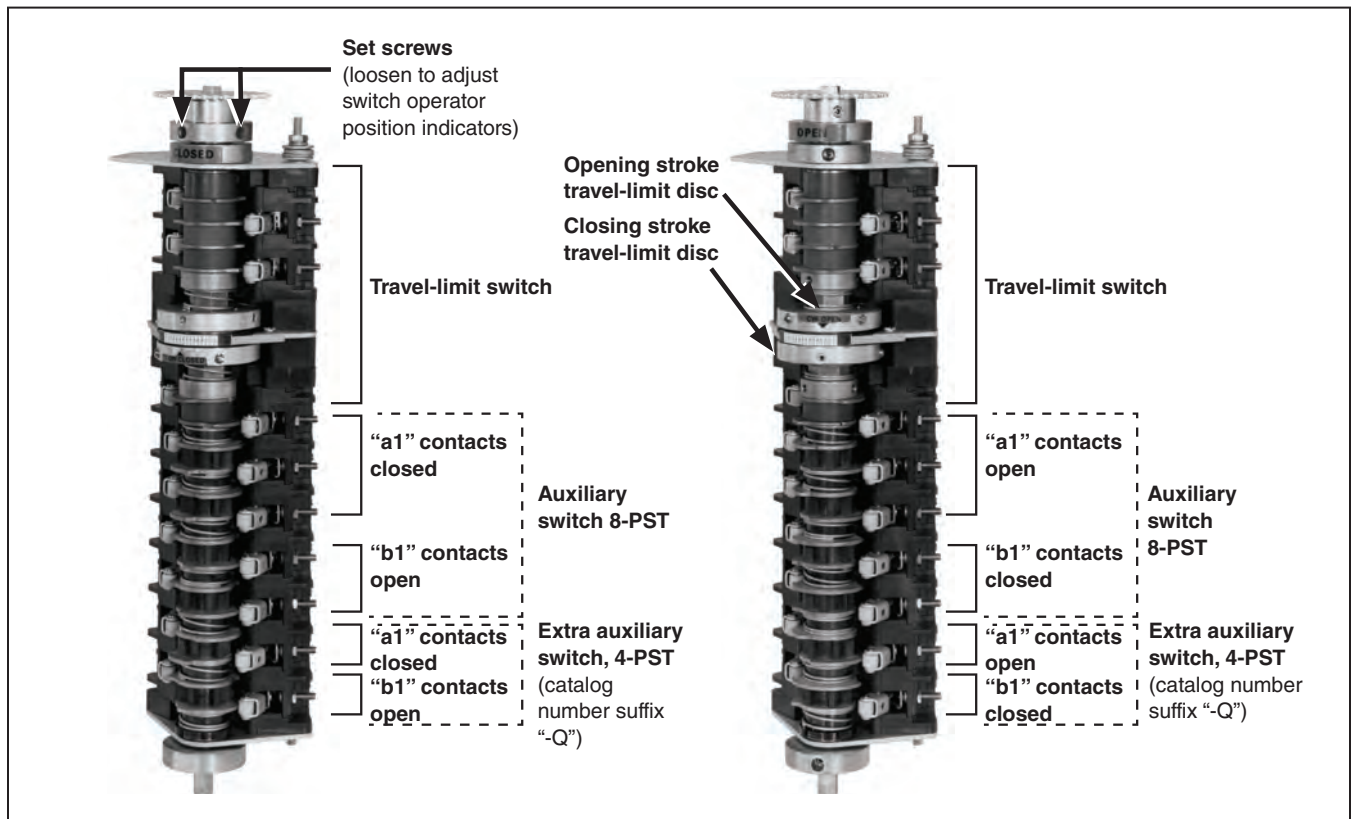

Figure 73. Travel limit switches.

Wiring and Adjusting the Switch Operator

STEP 13. Switch operators furnished with suffix “-W” or “-Z” are equipped with an extra auxiliary switch coupled to the disconnect. The suffix “-W” auxiliary switch consists of eight contacts, Terminals 35 through 50. The suffix “-Z” auxiliary switch consists of 12 contacts, Terminals 35 through 50 plus Terminals 80 through 87.

These contacts permit external circuits to be established to monitor disconnect operation. A cam-actuated roller operates each contact, and the cams are individually adjustable in 4.5-degree increments.

The “standard” configuration for the suffix “-W” extra auxiliary switch consists of four “a2” contacts, Terminals 35 through 42, and four “b2” contacts, Terminals 43 through 50. The “standard” configuration for the suffix “-Z” extra auxiliary switch consists of six “a2” contacts, Terminals 35 through 42 and Terminals 80 through 83, and six “b2” contacts, Terminals 43 through 50 and Terminals 84 through 87.

With the disconnect in the fully **Closed** position, the “a2” contacts should be closed and the “b2” contacts should be open. With the disconnect in the fully **Open** position, the “a2” contacts should be open and the “b2” contacts should be **Closed**. See Figure 74.

Any suffix “-W” or “-Z” auxiliary switch contact being used must be checked for proper operation after satisfactory electrical operation of the disconnect has been achieved. Check the auxiliary-switch contact engagement for both the **Open** and **Closed** positions of the disconnect. Adjustment of the suffix “-W” or “-Z” extra auxiliary switch is identical to the procedure for the auxiliary switch and the suffix “-Q” extra auxiliary switch. If adjustment of the suffix “-W” or “-Z” auxiliary switch is needed, refer to Step 12 on page 46 and Figure 72 on page 46 and Figure 74 on page 48.

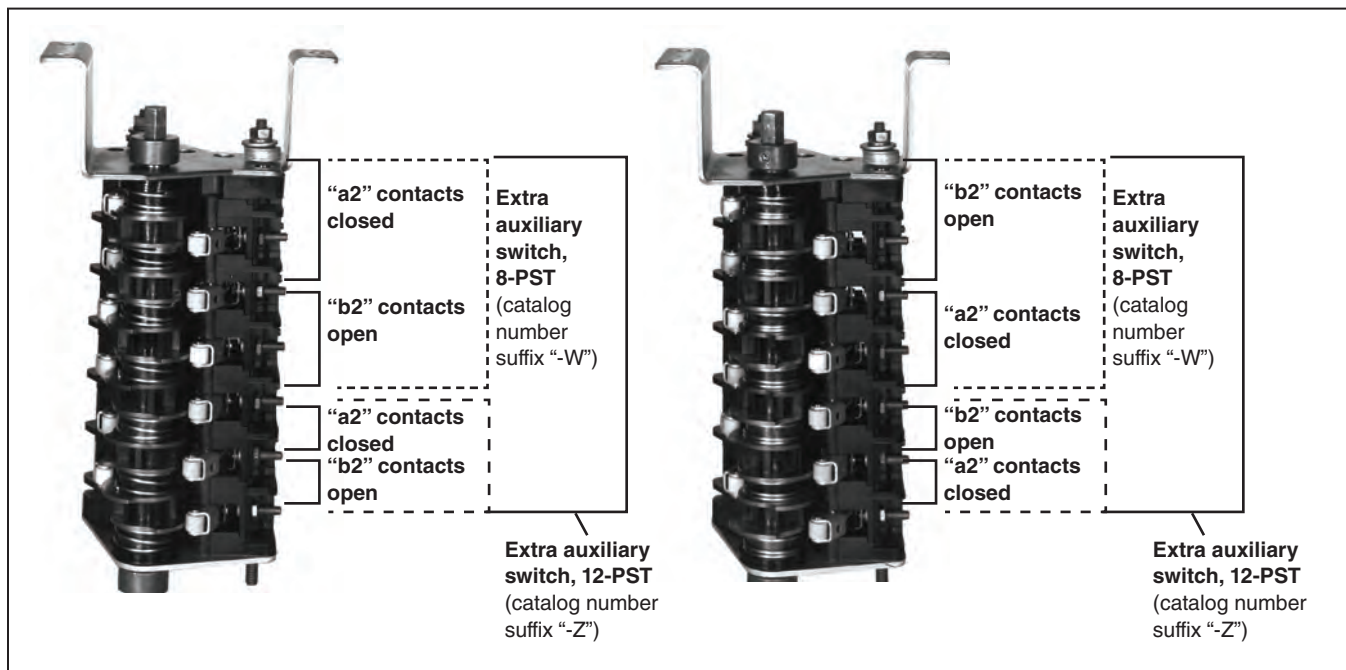

Figure 74. Auxiliary switches.

STEP 14. Make sure all protective-relay, control-circuit, and control-power wiring is complete. At this time, wire the interrupters and charging motors to the Mark VI CS-1A Switch Operator using the following procedure:

- (a) Disconnect power to the Mark VI CS-1A Switch Operator by removing the motor-circuit fuseholder inside the operator enclosure.
- (b) With control power disconnected, remove the temporary jumpers between the interrupter contacts. Discard the jumpers. See Figure 75.
- (c) Following the wiring diagram furnished, make up the electrical connections from the charging motors and interrupters to the appropriate terminal blocks inside the Mark VI CS-1A Switch Operator. Do not apply control power at this time.

Control power will be applied during "Startup" on page 52.

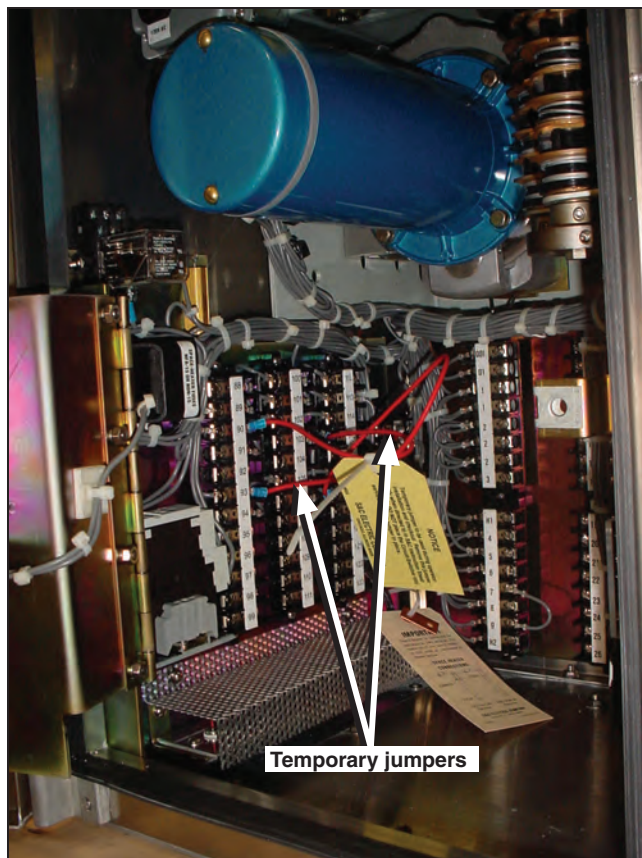

Figure 75. Remove temporary jumpers and wire the interrupters to the appropriate terminals in the Mark VI CS-1A Switch Operator per the wiring diagram.

Terminal Pads and Conductor Connections

Installing the Terminal Pad

Repeat Step 1 through Step 2 for each pole-unit.

NOTICE

Do not exceed the terminal pad loading limits outlined in S&C Information Bulletin 712-60. **Failure to do so can result in damage to the Mark VI Circuit-Switcher.**

STEP 1. Remove the lifting bracket from the interrupter. Make sure all packing material has been removed from the top of the interrupter. See Figure 76.

NOTICE

The lifting brackets must be removed before energizing the Mark VI Circuit-Switcher. **Failure to do so can result in damage to the interrupters.**

STEP 2. Prepare the interrupter terminal pad attachment as follows:

- Thoroughly clean the terminal pad using a soft cloth.
- Thoroughly wire-brush the appropriate set of holes on the interrupter casting.
- Immediately apply a liberal coating of Burndy Penetrox A or other suitable aluminum connector compound to the clean surfaces.
- Apply Penetrox A to the threads of two $\frac{1}{2}$ -13 \times 1-inch hex-head stainless steel cap screws furnished.
- Attach the terminal pad to the appropriate set of tapped holes on the interrupter. Tighten the screws to a torque of 40 to 50 ft.-lbs. See Figure 77.

NOTICE

Do not use a wire brush to clean the upper terminal pad. Abrasive cleaning may damage the terminal pad plating and cause corrosion.

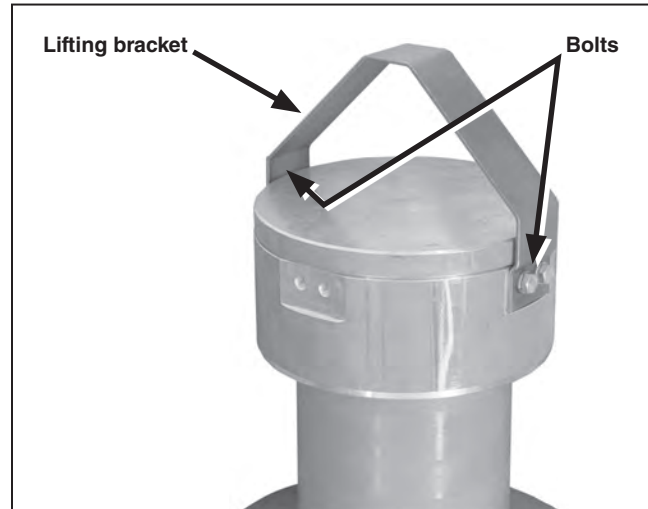

Figure 76. Remove the lifting bracket.

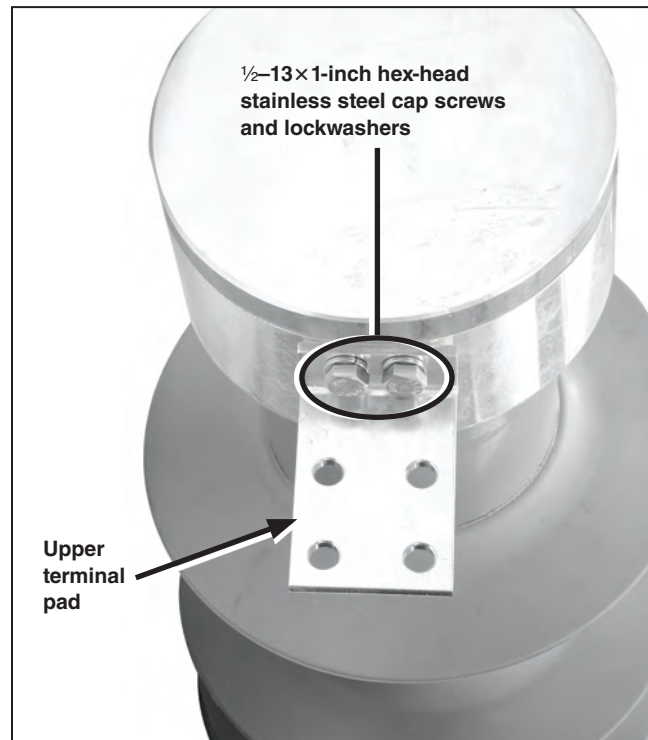

Figure 77. Bolt the upper terminal pad to the interrupter.

STEP 3. Prepare the jaw-end terminal pad as follows:

- (a) Thoroughly wire-brush the terminal pad casting.
- (b) Immediately apply a liberal coating of Burndy Penetrox A or other suitable aluminum connector compound to the clean surface. See Figure 78.

Connecting Conductors

⚠ DANGER

Conductors must be de-energized and grounded in accordance with standard system operating practice. **Failure to do so will result in serious injury or death.**

STEP 1. Attach the conductors to their respective terminal pads using flexible-conductor connections. Attach and form the conductors to minimize terminal-pad loadings. Do not exceed the terminal-pad loadings specified in S&C Information Bulletin 712-60.

STEP 2. After attaching conductors, recheck the alignment of the blade as described in Step 2 on page 20.

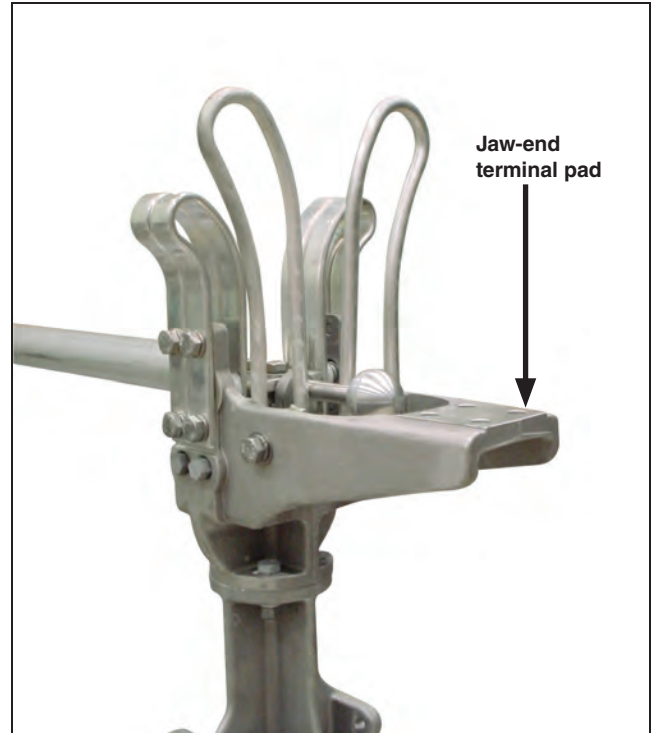

Figure 78. Prepare the jaw-end terminal pad.

Startup

⚠ DANGER

Conductors must be de-energized and grounded in accordance with standard system operating practice during checkout. **Failure to do so will result in serious injury or death.**

STEP 1. Verify the disconnect is in the **Coupled** position by looking at the internal decoupling mechanism inside the Mark VI CS-1A Switch Operator. See Figure 79 and Figure 80. If the switch operator is in the **Decoupled** position, manually operate the switch operator to bring it into the same position as the disconnect (**Open** or **Closed**). See Figure 80. For instructions on coupling the switch operator, refer to "Using the Selector Handle (Coupling and Decoupling)" on page 36.

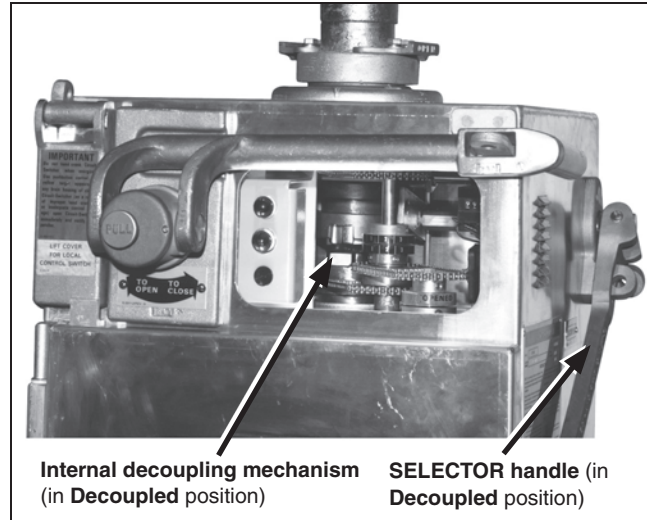

Figure 79. View of a decoupled switch operator through the observation window.

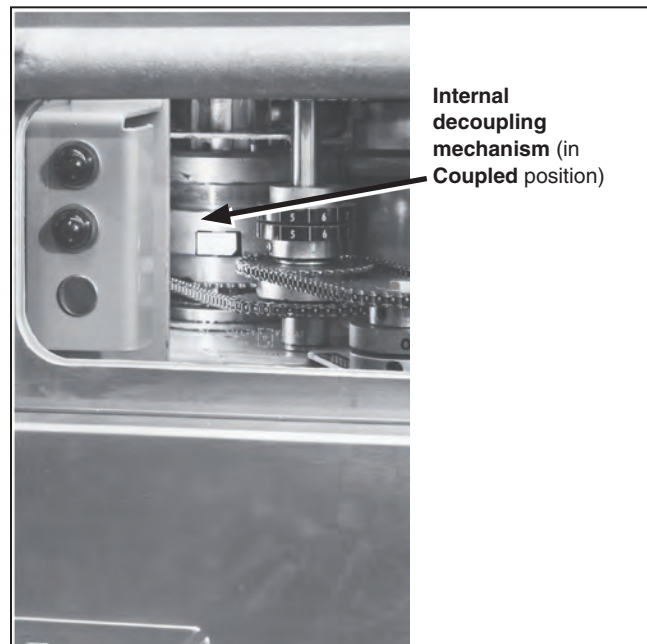

Figure 80. View of a coupled switch operator through the observation window.

STEP 2. Crank the MANUAL OPERATING handle on the Mark VI CS-1A Switch Operator until the disconnect is in the fully **Open** position. Visually inspect the blades to confirm they are open. See Figure 81. For instructions on using the MANUAL OPERATING handle, refer to "Using the Manual Operating Handle" on page 35.

STEP 3. Verify the interrupters are in the **Open** position and the gas-pressure gauge on the underside of each interrupter is in the OK to Operate zone. See Figure 81 and Figure 82.

NOTICE

The gas-pressure gauge needle should be in the OK to Operate zone. If the gauge is not in this position, stop the installation and notify the S&C Electric Company.



Figure 81. Disconnect blades in Open position.



Figure 82. Make sure the indicator reads "OPEN." Make sure the gas-pressure gauge on each interrupter is in the OK to Operate zone.

Circuit-Switcher Startup and Checkout

- STEP 4.** Reconnect control power to the operator by replacing the motor-circuit fuseholder in the Mark VI CS-1A Switch Operator. The charging motors should begin closing and charging the interrupters.

NOTICE

The interrupter charging motors have a **Return to Home** feature. If control power is disconnected during an interrupter **Charging** operation, upon restoration of control power, the circuit will prompt the motors to return to **Home** position:

If control power was disconnected prior to the interrupters being latched and closed: The motor will return to the start of the charging cycle (**Home** position), and the interrupter indicators will show **Open** before the charging cycle begins again.

If control power was disconnected after the interrupters were latched and closed: The motor will back out to the **Home** position, and the interrupter indicators will show **Closed**.



DANGER

Conductors must be de-energized and grounded in accordance with standard system operating practice. **Failure to do so will result in serious injury or death.**

- STEP 5.** If the interrupter charging motors do not immediately begin charging, remove the motor-circuit fuseholder, recheck the wiring connections per the furnished wiring diagram, and reapply power to the operator. If the motors still do not start, stop the installation and notify S&C Electric Company.

Checkout

The following instructions assume the switch operator output shaft has been connected to the disconnect drive train, the electrical connections to the control source have been completed, and the switch operator has been correctly adjusted.

Using this instruction sheet, the furnished reference drawing, and S&C Instruction Sheet 712-501 as a guide, visually inspect the entire installation. Verify the following:

Mounting Pedestals

- Make sure both the upper and lower sets of anchor bolt nuts are in contact with the pedestal base.
- Make sure the fasteners for the support arms, switch base, channel assembly, cross braces, and pole-unit bases are securely tightened.
- Make sure all packaging materials, lifting brackets, and eyebolts have been removed.

Pole-Units

- Make sure fasteners for the interrupter mounting brackets, support brackets, and motor brackets are securely tightened.
- Make sure all packaging materials, lifting brackets, and eyebolts have been removed.
- Make sure conduit is securely fastened to the mounting pedestals, and all conduit fasteners furnished have been used.
- Check for damage to the insulators and interrupters. Clean dirt and grease from the insulation.
- Make sure the TEMPORARY MANUAL OPERATING handle is not attached to a disconnect. If it is, remove it.
- Check for torque in the bus connection between the interrupters and disconnect. Loosen and reposition interrupter base if necessary.

Circuit-Switcher Startup and Checkout

Drive Train

- Make sure all drive-train couplings are secure, and none of the piercing set screws are loose or protruding through the coupling clamp.
- Make sure the grounding strap attached to the base of the vertical operating shaft is properly grounded.
- Make sure the gearbox is level, and all fasteners are secure.

Mark VI CS-1A Switch Operator

- Make sure all electrical connections are landed on the appropriate terminal blocks, per the furnished wiring diagram.
- Make sure all terminal block screws are secure.
- Make sure the temporary jumpers have been removed and discarded.
- Make sure all control-power and wiring conduit entrances are sealed with a watertight sealant.

The switch can now be operated according to the instructions in S&C Instruction Sheet 712-501.



Figure 83. Completed Mark VI Circuit-Switcher installation.

Understanding the Interrupter Indicators

An interrupter indicator is provided underneath each interrupter base. The indicator is not meaningful while the interrupter is being closed and charged.

If the interrupter is **Open and Discharged**, the indicator shows “OPEN.” See Figure 84.

If the interrupter is **Closed and Charged**, the indicator shows “CLOSED.” See Figure 85.

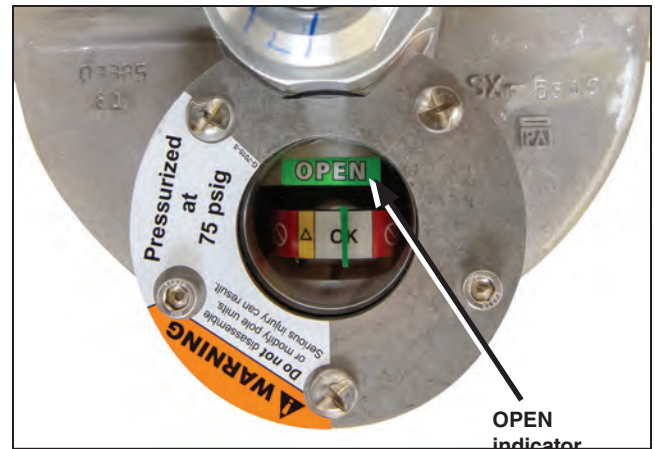

Figure 84. The interrupter is Open and Discharged. The indicator shows “OPEN.”



Figure 85. The interrupter is Closed and Charged. The indicator shows “CLOSED.”

Understanding the Gas-Pressure Gauge

A temperature-compensated gas-pressure gauge is provided underneath each interrupter base. It shows whether SF₆ gas density is sufficient for interrupting faults at full rating. The gas-pressure gauge shows three zones:

OK to Operate

This is the white zone. If the gauge needle is in this zone, the interrupter is at normal gas density and can be opened and closed. See Figure 86.

OK to Operate (but replace)

This is the yellow zone. If the gauge needle is in this zone, the interrupter can be opened and closed with full ratings. However, the interrupter has lost gas and should be replaced as soon as possible. See Figure 87.



Figure 86. Gauge needle in white OK to Operate zone.



Figure 87. Gauge needle in yellow OK to Operate (but Replace) zone.

Replace

There are two red zones. If the indicator needle is in the red zone shown in Figure 88, the gas density in the interrupter has dropped below the minimum functional level, and the interrupter will not maintain full interrupting or dielectric ratings. The interrupter should be removed from service and replaced promptly. Do not operate the Mark VI Circuit-Switcher.

If the indicator needle is in the red zone next to the "OK" zone as shown in Figure 89, the internal gas density gauge is damaged and cannot be relied on to provide an accurate indication of gas density. The interrupter should be removed from service and replaced promptly. Contact the local S&C Electric Company Sales Office. Do not operate the Mark VI Circuit-Switcher.

NOTICE

At temperatures below -31°F (-35°C), the indicator needle will be in the red zone because of the cold temperature. The normal operating temperature for the Mark VI Circuit-Switcher is -31°F (-35°C) to $+104^{\circ}\text{F}$ (40°C); below -31°F (-35°C), the gas density does not allow the full interrupting or dielectric capability of the switch. **At these temperatures, the gas-pressure gauge does not accurately indicate whether an interrupter is losing SF_6 gas.**



Figure 88. Gauge needle in red Replace zone.



Figure 89. The other red Replace zone.

Understanding the Optional Remote Gas-Density Indicator

If furnished, the remote gas-density indicator provides contacts for each interrupter, allowing remote monitoring of two low-gas-pressure alarms:

Level 1 Alarm

When a **Level 1** Alarm is issued, the interrupter can be opened and closed as usual. However, the interrupter has lost gas and should be replaced as soon as possible.

The remote gas-density **Level 1** alarm contact opens at 95% of normal density, or 70 psig at 68°F (20°C). Contacts are normally closed at normal operating gas pressure.

Level 2 Alarm

When a **Level 2** Alarm is issued, the gas density in the interrupter has dropped below the minimum functional level. The interrupter will not maintain full interrupting or dielectric ratings. The interrupter should be removed from service and replaced promptly. Do not operate the Mark VI Circuit-Switcher.

The remote gas-density **Level 2** alarm contact opens at 88% of normal density, or 65 psig at 68°F (20°C). Contacts are normally closed at normal operating gas pressure.

NOTICE

At temperatures below -31°F (-35°C), a **Level 2** alarm may be issued because of the cold temperature. The gas density is below the minimum functional level, so the circuit-switcher will not have full interrupting or dielectric ratings. **At these temperatures, a Level 2 Alarm does not accurately indicate whether an interrupter is losing SF₆ gas.**