

# Installation

## Table of Contents

<b>Introduction</b> .....	<b>2</b>	<b>Wiring and Adjusting the Switch Operator</b> ....	<b>27</b>
Qualified Persons .....	2	Before Starting .....	27
Read This Instruction Sheet .....	2	Connecting Control Power and User-Furnished	
Retain This Instruction Sheet .....	2	Control Circuits .....	28
Proper Application .....	2	Using the Manual Operating Handle .....	30
<b>Safety Information</b> .....	<b>3</b>	Using the Selector Handle (Coupling and	
Understanding Safety-Alert Messages .....	3	Decoupling) .....	31
Following Safety Instructions .....	3	Adjusting the Switch Operator .....	33
Replacement Instructions and Labels .....	3	<b>Terminal Pad and Conductor Connections</b> ....	<b>44</b>
Location of Safety Labels .....	4	Installing the Terminal Pad .....	44
<b>Safety Precautions</b> .....	<b>5</b>	Connecting Conductors .....	45
<b>Shipping and Handling</b> .....	<b>6</b>	<b>Circuit-Switcher Startup and Checkout</b> .....	<b>46</b>
Inspection .....	6	Startup .....	46
Packing .....	6	Checkout .....	48
Storage .....	6	<b>Indicators</b> .....	<b>49</b>
<b>Installation</b> .....	<b>7</b>	Understanding the Interrupter Indicators .....	49
Before Starting .....	7	Understanding the Gas-Pressure Gauge .....	49
Installing the Disconnect Pole-Units .....	8	Understanding the Optional Remote	
Installing the Interrupters, Motor Brackets,		Gas-Density Indicator .....	51
and Buswork .....	9		
Checking the Operation of the Disconnect .....	14		
Installing the Drive Train, Gearbox, and			
Interphase Shaft .....	16		
Installing the Mark VI CS-1A Switch Operator			
and Vertical Shaft .....	19		
Installing the Interrupter Charging Motors .....	22		
Installing the User-Furnished Conduit .....	24		
Wiring the Interrupters and Charging Motors .....	25		



## Introduction

---

### Qualified Persons

#### **WARNING**

Only qualified persons knowledgeable in the installation, operation, and maintenance of overhead and underground electric transmission and distribution equipment, along with all associated hazards, may install, operate, and maintain the equipment covered by this publication. A qualified person is someone trained and competent in:

- The skills and techniques necessary to distinguish exposed live parts from nonlive parts of electrical equipment
- The skills and techniques necessary to determine the proper approach distances corresponding to the voltages to which the qualified person will be exposed
- The proper use of special precautionary techniques, personal protective equipment, insulated and shielding materials, and insulated tools for working on or near exposed energized parts of electrical equipment

These instructions are intended only for such qualified persons. They are not intended to be a substitute for adequate training and experience in safety procedures for this type of equipment.

### Read This Instruction Sheet

#### **NOTICE**

Thoroughly and carefully read this instruction sheet and all materials included in the product's instruction handbook before installing or operating the Mark VI Circuit-Switcher. Become familiar with the Safety Information on pages 3 through 4 and Safety Precautions on page 5. The latest version of this publication is available online in PDF format at [sandc.com/en/product-literature/](http://sandc.com/en/product-literature/).

### Retain This Instruction Sheet

This instruction sheet is a permanent part of the Mark VI Circuit-Switcher. Designate a location where users can easily retrieve and refer to this publication.

### Proper Application

#### **WARNING**

The equipment in this publication is only intended for use in the switching and protection of capacitor banks and substation transformers. The applications must be within the ratings furnished for the equipment. The ratings for this Mark VI Circuit-Switcher are listed on the nameplate on the side of the Mark VI CS-1A Switch Operator. They can also be found in S&C Specification Bulletin 712-31.

**Understanding Safety-Alert Messages**

Several types of safety-alert messages may appear throughout this instruction sheet and on labels and tags attached to the product. Become familiar with these types of messages and the importance of these signal words:

<b>⚠ DANGER</b>
“DANGER” identifies the most serious and immediate hazards that will likely result in serious personal injury or death if instructions, including recommended precautions, are not followed.

<b>⚠ WARNING</b>
“WARNING” identifies hazards or unsafe practices that can result in serious personal injury or death if instructions, including recommended precautions, are not followed.

<b>⚠ CAUTION</b>
“CAUTION” identifies hazards or unsafe practices that can result in minor personal injury if instructions, including recommended precautions, are not followed.

<b>NOTICE</b>
“NOTICE” identifies important procedures or requirements that can result in product or property damage if instructions are not followed.

**Following Safety Instructions**

If any portion of this instruction sheet is unclear and assistance is needed, contact the nearest S&C Sales Office or S&C Authorized Distributor. Their telephone numbers are listed on S&C’s website [sandc.com](http://sandc.com), or call the S&C Global Support and Monitoring Center at 1-888-762-1100.

<b>NOTICE</b>	
Read this instruction sheet thoroughly and carefully before installing the S&C Mark VI Circuit-Switcher.	

**Replacement Instructions and Labels**

If additional copies of this instruction sheet are required, contact the nearest S&C Sales Office, S&C Authorized Distributor, S&C Headquarters, or S&C Electric Canada Ltd.

It is important any missing, damaged, or faded labels on the equipment be replaced immediately. Replacement labels are available by contacting the nearest S&C Sales Office, S&C Authorized Distributor, S&C Headquarters, or S&C Electric Canada Ltd.

## Location of Safety Labels

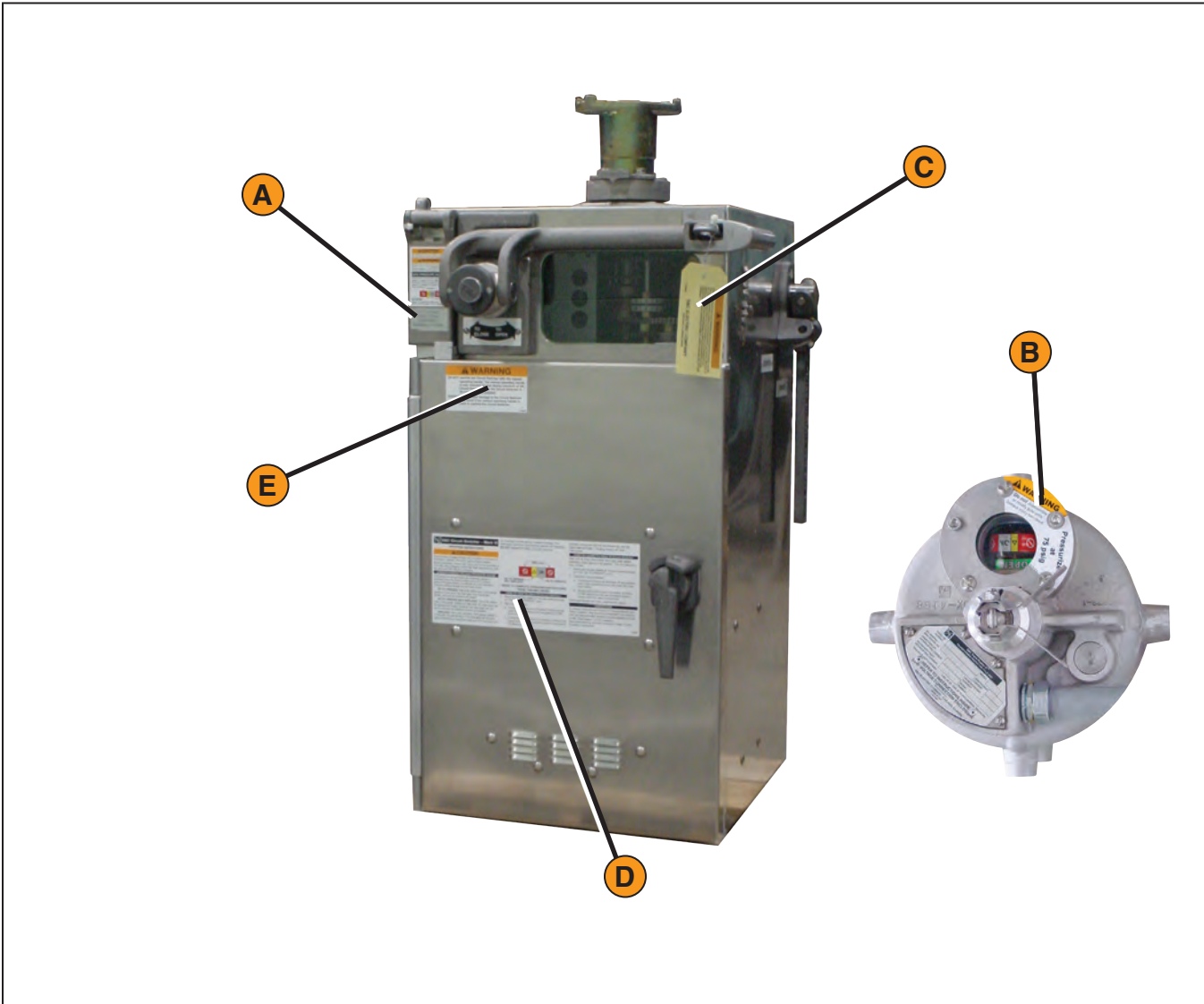

## Reorder Information for Safety Labels

Location	Safety Alert Message	Description	Part Number
<b>A</b>	<b>⚠ WARNING</b>	Use push button control to open or close ...	G-9025
<b>B</b>	<b>⚠ WARNING</b>	Do not disassemble or modify ...	G-7015-5
<b>C</b>	<b>⚠ WARNING</b>	Do not operate the Circuit-Switcher with ...	G-9024
<b>D</b>	<b>⚠ WARNING</b>	Unauthorized changes should not be made ...	G-9027
<b>E</b>	<b>⚠ WARNING</b>	Do not operate the Circuit-Switcher with ...	G-9026
<b>F</b>	<b>NOTICE</b>	This contactor or relay has been blocked...	G-3684R4 ● ■
<b>G</b>	<b>NOTICE</b>	The S&C Instruction Sheet is a permanent part...	G-3733R2 ●
<b>H</b>	<b>NOTICE</b>	Auxiliary switch cams are individually adjustable.	G-4746R2 ●

- Label should be removed before placing the circuit-switcher in service.
- Label is inside the operator and not visible in photo.

**⚠ DANGER**



**S&C Mark VI Circuit-Switchers operate at high voltage. Failure to observe the precautions below will result in serious personal injury or death.**

Some of these precautions may differ from your company's operating procedures and rules. Where a discrepancy exists, follow your company's operating procedures and rules.

- |   |  |
|---|--|
| <ol style="list-style-type: none"> <li>1. <b>QUALIFIED PERSONS.</b> Access to S&amp;C Mark VI Circuit-Switchers must be restricted only to qualified persons. See "Qualified Persons" on page 2.</li> <li>2. <b>SAFETY PROCEDURES.</b> Always follow safe operating procedures and rules.</li> <li>3. <b>PERSONAL PROTECTIVE EQUIPMENT.</b> Always use suitable protective equipment such as rubber gloves, rubber mats, hard hats, safety glasses, and flash clothing, in accordance with safe operating procedures and rules..</li> <li>4. <b>SAFETY LABELS.</b> Do not remove or obscure any of the "DANGER," "WARNING," "CAUTION," or "NOTICE" labels.</li> <li>5. <b>ENERGIZED COMPONENTS.</b> Always consider all parts live until de-energized, tested, and grounded. Voltage levels can be as high as the peak line-to-ground voltage last applied to the unit. Units that have been energized or installed near energized lines should be considered live until tested and grounded.</li> <li>6. <b>GROUNDING.</b> The Mark VI Circuit-Switcher must be connected to a suitable earth ground at the</li> </ol> | <p>base of the utility pole, or to a suitable building ground for testing, before energizing the switch and at all times when energized.</p> <p>The ground wire(s) must be bonded to the system neutral, if present. If the system neutral is not present, proper precautions must be taken to ensure the local earth ground, or building ground, cannot be severed or removed.</p> <ol style="list-style-type: none"> <li>7. <b>CIRCUIT-SWITCHER POSITION.</b> Always confirm the <b>Open/Close</b> position of circuit-switchers by visually observing the position of the blades. Switches may be energized from either side and with the blades in either position.</li> <li>8. <b>MAINTAINING PROPER CLEARANCE.</b> Always maintain proper clearance from energized components.</li> <li>9. <b>OPERATION.</b> Circuit making and breaking is involved in the normal operation of this interrupter switch and, as a result, "partway" opening or closing is undesirable. To operate, follow the operating procedure as outlined in S&amp;C Instruction Sheet 712-501.</li> </ol> |
|---|--|

## Shipping and Handling

---

### Inspection

Examine the shipment for external evidence of damage as soon after receipt as possible, preferably before removal from the carrier's conveyance. Check the bill of lading to make sure all listed shipping skids, crates, and containers are present.

If there is visible loss and/or damage:

1. Notify the delivering carrier immediately.
2. Ask for a carrier inspection.
3. Note the condition of shipment on all copies of the delivery receipt.
4. File a claim with the carrier.

If concealed damage is discovered:

1. Notify the delivering carrier within 15 days of receipt of shipment.
2. Ask for a carrier inspection.
3. File a claim with the carrier.

Also, notify S&C Electric Company in all instances of loss and/or damage.

### Packing

An S&C catalog drawing and/or erection drawing will be found in a water-resistant envelope attached to the interrupter container on one of the three circuit-switcher pole-unit disconnects. A packing list is included. Please use the packing list to confirm all parts have been received before beginning assembly. Keep the packing list for future reference.

The Mark VI Circuit-Switcher shipment includes all three phases of the integral disconnect mounted on a single skid. Each phase is factory-assembled and adjusted. Drive-train operating shafts, interphase couplings, mounting hardware, and a temporary hand adapter for checking the operation of the integral disconnects—all individually identified—are also packed with the disconnect pole-units. The interphase and vertical shafts are cut to length.

Three interrupters are packed in a separate crate along with associated mounting hardware. Three interrupter charging motors and their associated mounting hardware are packed in a separate crate. The Mark VI CS-1A Switch Operator is shipped on a separate

skid. If furnished, options such as a grounding switch or pre-insertion inductors are shipped in their own crates.

### WARNING

**DO NOT** disassemble or modify the pole-units. The pole-units are pressurized at 75 PSIG. **Serious injury can result.**

### Storage

#### NOTICE

The Mark VI CS-1A Switch Operator is equipped with a space heater that must be energized during storage to prevent condensation and corrosion within the operator enclosure.

If the circuit-switcher must be stored before installation, keep it in a clean, dry, corrosion-free area to protect it from damage. Make sure each skid rests firmly on the ground and is reasonably level. Shoring under the skids may be necessary if the ground is uneven.

If storing outdoors, connect control power to the space heater inside the Mark VI CS-1A Switch Operator per the wiring diagram furnished. Inspect the circuit-switcher regularly when storing for prolonged periods.

**Before Starting****⚠ WARNING**

The user-furnished mounting structure must meet the guidelines for static and dynamic loading limits listed in S&C Information Bulletin 712-60. **Failure to observe these guidelines can result in equipment damage and personal injury.**

If a detailed technical drawing of the user-furnished mounting structure was supplied when the switch was ordered, appropriate mounting holes will be pre-drilled in the base of each pole-unit. Mounting brackets, channel sections, or spacers may be supplied with the Mark VI Circuit-Switcher to facilitate installation on the existing user-furnished structure. Refer to the supplied custom erection drawing for details.

If a detailed technical drawing of the user-furnished mounting structure was not supplied when the switch was ordered, the pole-units will be furnished with the mounting hole pattern appropriate for circuit-switchers installed on S&C Mounting Pedestals. A standard erection drawing and reference drawing will be supplied. Refer to this standard erection drawing for details.

- STEP 1.** Before removing the disconnect pole-units from the skid, arrange the skid on a level surface, in the position and order in which they will be raised onto the mounting structure, as shown on the associated erection drawing.
- STEP 2.** Unbolt the wooden cross braces securing the disconnect pole-units to each other. **DO NOT** unbolt the disconnect pole-units from the base of the shipping skid at this time. See Figure 1.

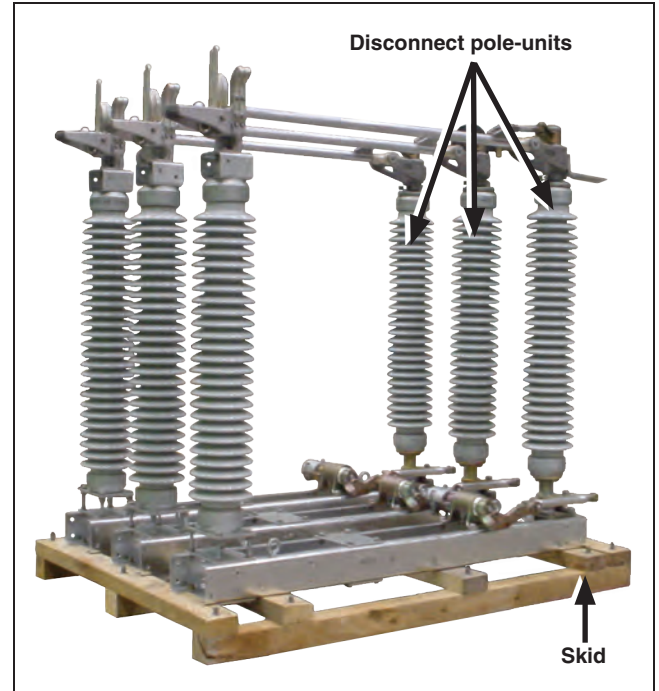

**Figure 1.** Remove all packing materials from the disconnect pole-units. **DO NOT** unbolt the disconnects from the skid until lifting slings are attached.

# Installation

## Installing the Disconnect Pole-Units

### NOTICE

A crane or other suitable lifting device is required to install the Mark VI Circuit-Switcher. Make sure an appropriate lifting device is available at the installation site before beginning the circuit-switcher installation.

Repeat Step 1 through Step 3 for each disconnect pole-unit.

**STEP 1.** Attach lifting slings to the eyebolts furnished on the pole-unit base. With the blade in the fully **Closed** position, unbolt the first pole-unit to be installed from the skid.

### ⚠ WARNING

**DO NOT** lift the disconnect pole-unit by the disconnect blade, contacts, or other live parts. Keep the blade in the Closed position during handling. Avoid sudden stops and starts. **Misalignment and damage to the disconnect and personal injury can occur if not lifted properly.**

**STEP 2.** Make sure the rigging does not stress the blade or blade contacts. Raise the disconnect to the appropriate elevation and position it over the correct set of mounting holes in the mounting structure. Avoid sudden starts and stops, and avoid contact with other objects. See Figure 2.

**STEP 3.** Bolt the hinge end of the disconnect pole-unit to the switch base using four  $\frac{5}{8}$ -11  $\times$  1 $\frac{1}{2}$ -inch hex-head cap screws, flat washers, and hex-head nuts provided.

Bolt the jaw end of the disconnect pole-unit to the channel assembly using two  $\frac{5}{8}$ -11  $\times$  2 $\frac{1}{4}$ -inch hex-head cap screws, flat washers, and hex head nuts. (Other mounting hardware sizes may be required. Refer to the erection drawing for details on the pole-unit base mounting hole arrangement.) See Figure 3.

Remove lifting slings. Remove eyebolts and discard.

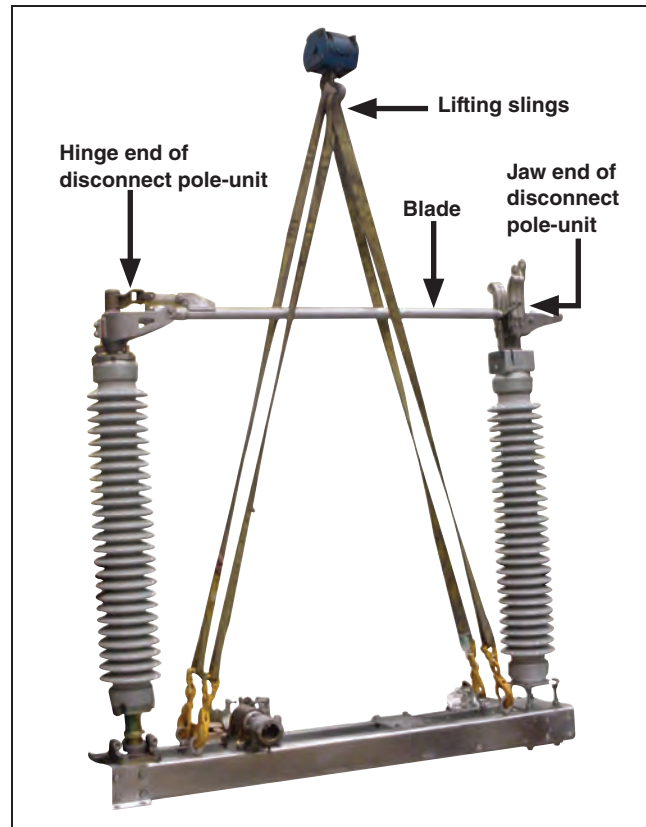

Figure 2. Attach the lifting slings to the disconnect pole-unit and raise it into place on the structure.

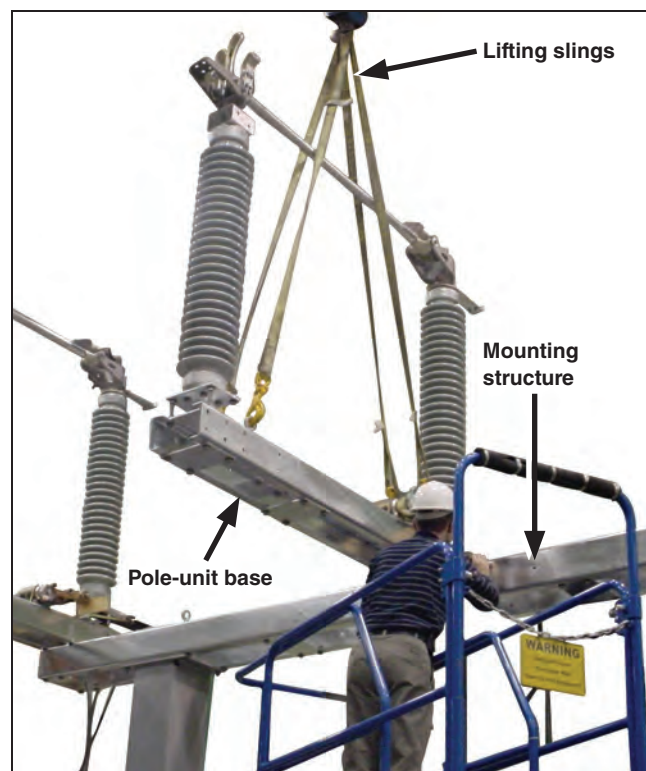

Figure 3. Secure the disconnect pole-unit to the user-furnished structure.

## Installing the Interrupters, Motor Brackets, and Buswork

Repeat Step 1 through Step 11 on page 13 for each interrupter.

**STEP 1.** Remove the interrupter from its shipping crate and lift it using the following procedure:

### NOTICE

Lift the interrupter **ONLY** by the lifting bracket. **Lifting it by any other means can damage the interrupter.**

- (a) Wrap a lifting sling around the lifting bracket at the top of the interrupter.
- (b) Carefully raise the interrupter upward. The foam wrappings around the top, mid-section, and base should come off as the interrupter is being lifted. Remove these wrappings if they do not come off by themselves. Do not remove the shipping brace at this time. See Figure 4, Figure 5, and Figure 6.

### NOTICE

**DO NOT** remove the shipping brace around the base of the interrupter at this time. **Damage to the operating shaft can occur.**

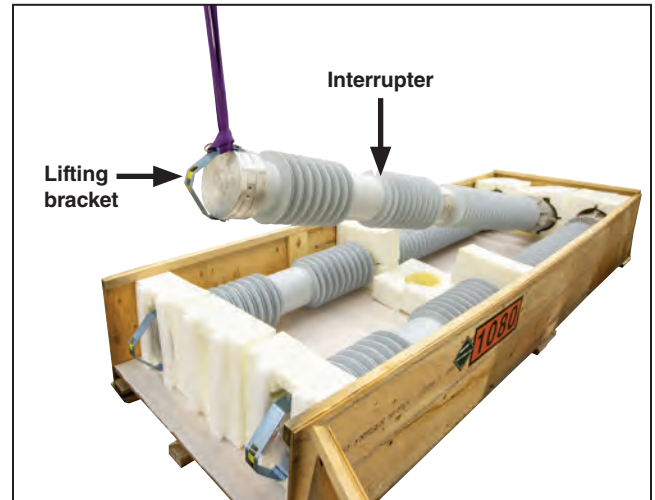

Figure 4. Lift the interrupter only by the lifting bracket.

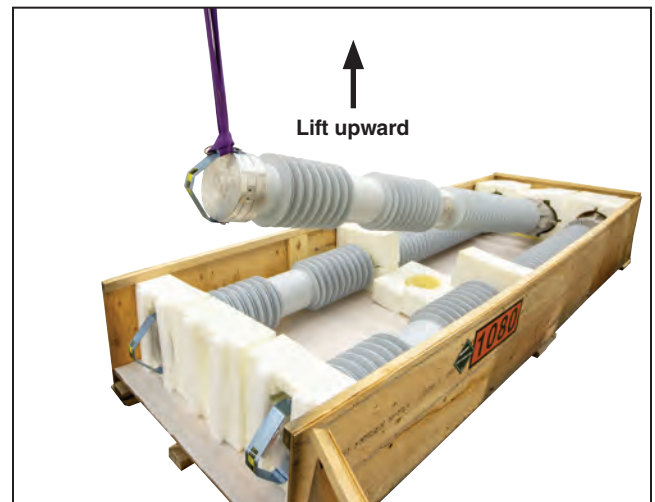

Figure 5. Lift the interrupter carefully upward.

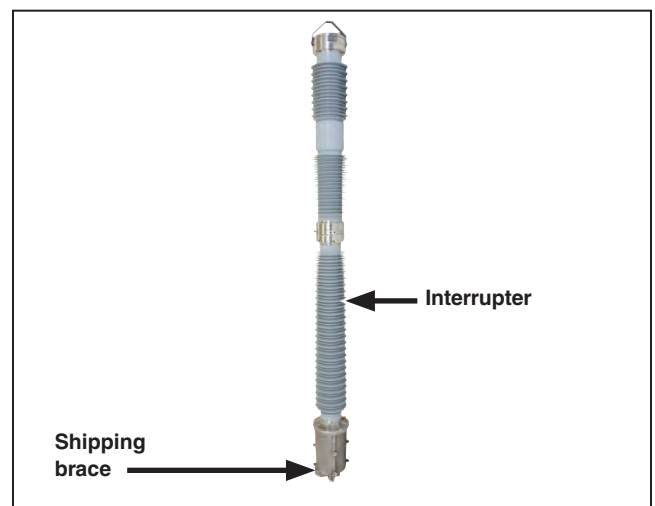

Figure 6. An interrupter with wrappings removed.

## Installation

**STEP 2.** With the interrupter lifted off the ground, make sure the gas-pressure gauge on the underside of the interrupter is in the OK to Operate zone. See Figure 7 and Figure 8.

### NOTICE

If the gauge is not in in the OK to Operate zone, stop the installation and notify S&C Electric Company.

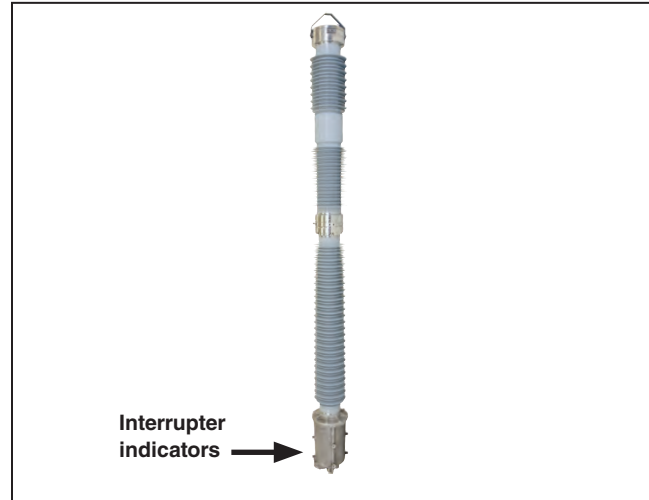

Figure 7. With the interrupter lifted off the ground, check the gas-pressure gauge on the underside of each interrupter.

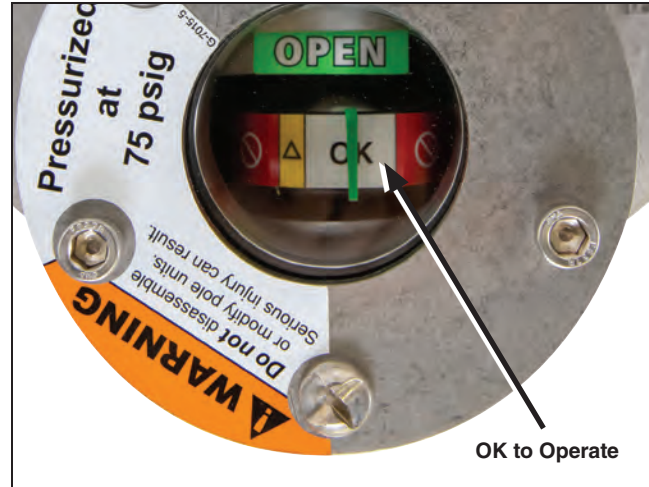

Figure 8. Make sure the gas-pressure gauge on each interrupter is in the OK to Operate zone.

**STEP 3.** Remove the shipping brace from the interrupter base. See Figure 9. Discard the bolt.

<b>NOTICE</b>
<p><b>DO NOT</b> rest the interrupter on its base after the shipping brace has been removed. <b>Damage to the operating shaft can occur.</b></p>

**STEP 4.** With the interrupter still hoisted off the ground, thread eight  $\frac{5}{8}$ -11  $\times$  2-inch stainless steel studs into the eight tapped interrupter mounting bosses on the base of the interrupter. Hand-tighten each stud eight to nine turns, until it bottoms. See Figure 9.

<b>⚠ WARNING</b>
<p><b>Never exceed the recommended torque limit.</b> The interrupter base is pressurized to 75 PSI. <b>Damage to the interrupter and personal injury can occur.</b></p>

**STEP 5.** Loosely assemble the two interrupter support brackets and the motor brackets to the interrupter base, as shown in Figure 10, using the installed  $\frac{5}{8}$ -11  $\times$  2-inch studs, flat washers, and uni-torque nuts furnished.

- (a) Install the cross support bracket between the two interrupter support brackets with the four  $\frac{5}{8}$ -11  $\times$   $2\frac{1}{4}$ -inch cap screws, lock washers, and nuts furnished. See Figure 10. The motor bracket should be mounted between the cross support bracket and the interrupter mounting bosses, with the L-shaped portion of the bracket facing away from the indicator window. See Figure 11.

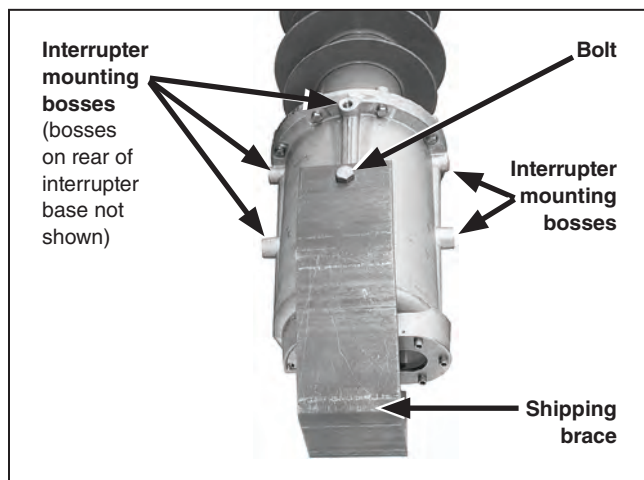

**Figure 9.** Remove the shipping brace to reveal the mounting bosses.

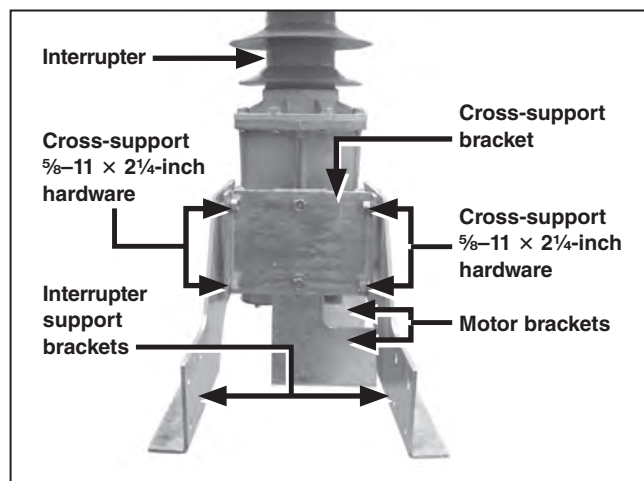

**Figure 10.** Assemble the mounting brackets to the interrupter (69-kV support brackets shown).

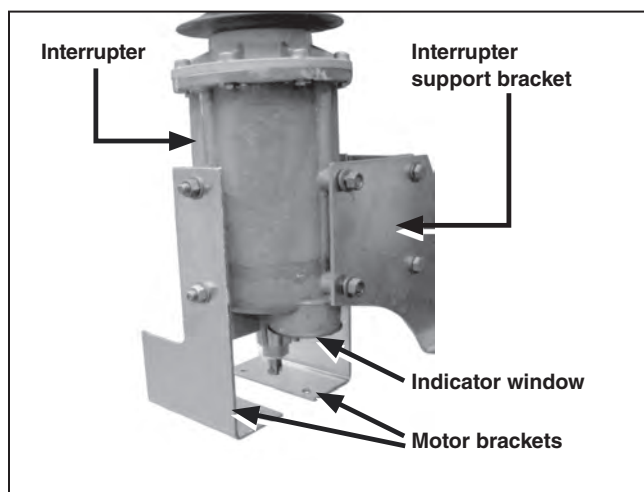

**Figure 11.** Make sure the L-shaped motor brackets are facing away from the indicator window.

## Installation

- STEP 6.** Position the interrupter mounting brackets so the holes in the brackets align with the holes in the pole-unit base. See Figure 12. Attach the interrupter mounting brackets to the pole-unit base using eight  $\frac{5}{8}$ -11  $\times$  2 $\frac{1}{4}$ -inch hex-head galvanized steel cap screws, flat washers, and nuts furnished.
- STEP 7.** Tighten all nuts on the interrupter and the base to a torque of 70 to 80 ft.-lbs.

### WARNING

**Never exceed the recommended torque limit.** The interrupter base is pressurized to 75 PSI. **Damage to the interrupter and personal injury can occur.**

- STEP 8.** Remove the lifting sling from the interrupter.
- STEP 9.** The interrupter-to-disconnect buswork assemblies are pre-assembled to ensure correct hardware placement. Unfasten all hardware before installation.

### NOTICE

**DO NOT wire-brush the buswork.** The buswork pieces are plated and do not require abrasive cleaning as part of their preparation. Wipe any dirt or grease from the surface and apply a thick coating of Burndy Penetrox® A or other appropriate conductor preparation compound. **Wire-brushing can damage the plating and cause corrosion.**

Prepare the electrical bus connection to the interrupter as follows:

- Thoroughly clean the interrupter bus with a soft cloth. Wire-brush the casting.
- Immediately apply a liberal coating of Penetrox A or other suitable aluminum connector compound to the clean surfaces.
- Apply a coating of Penetrox A to the threads of two  $\frac{1}{2}$ -13  $\times$  1-inch hex-head stainless steel cap screws.
- Attach the interrupter bus to the set of tapped holes in the interrupter, using the coated cap screws and two stainless steel lock washers. See Figure 13. Tighten the screws to a torque of 70 to 80 ft.-lbs.

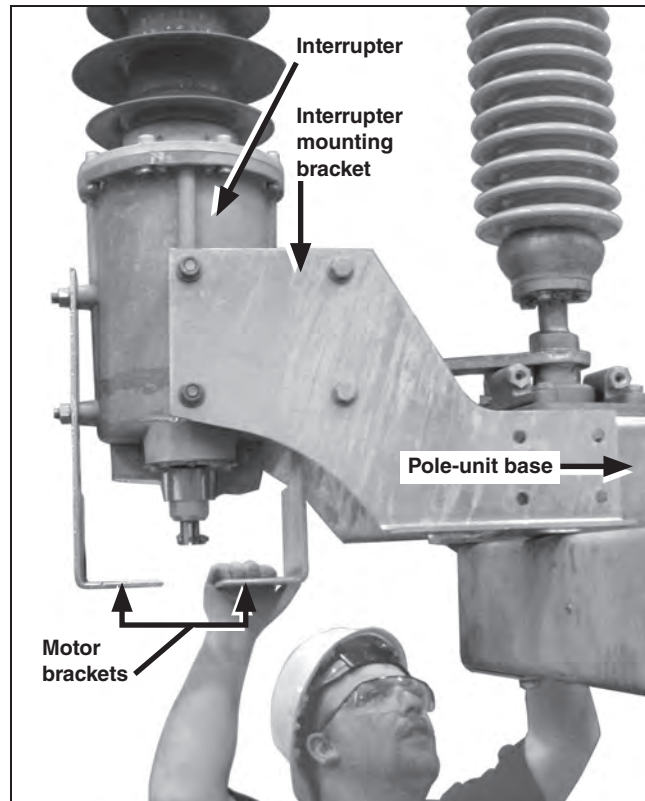

**Figure 12.** Attach the interrupter mounting bracket to the pole-unit base. Tighten the hardware.

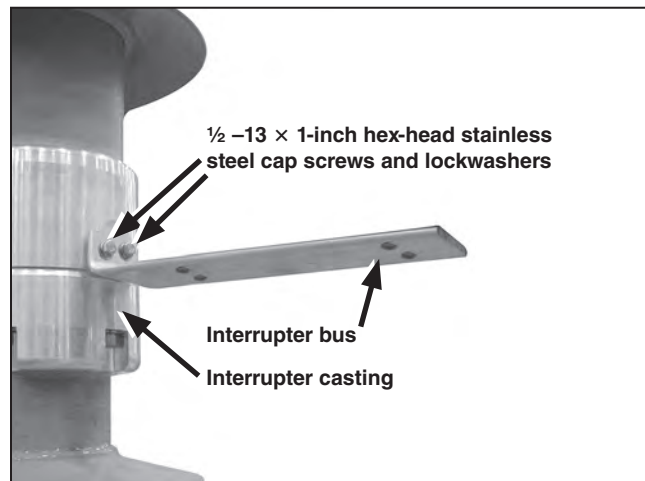

**Figure 13.** Attach the interrupter bus to the tapped holes on the interrupter casting.

**STEP 10.** Prepare the electrical connection to the disconnect bus as follows:

- (a) Thoroughly clean the interrupter bus with a soft cloth. Wire-brush the disconnect casting.
- (b) Immediately apply a liberal coating of Penetrox A or other suitable aluminum connector compound to the clean surfaces.
- (c) Apply a coating of Penetrox A to the threads of two  $\frac{1}{2}$ -13  $\times$   $\frac{1}{4}$ -inch hex-head stainless steel cap screws.
- (d) Attach the disconnect bus to the set of tapped holes in the disconnect casting, using the coated cap screws and four  $\frac{1}{2}$ -inch stainless steel Belleville washers. See Figure 14. Tighten the screws to a torque of 50 to 60 ft.-lbs.

**STEP 11.** Attach the interrupter bus to the disconnect bus using the four  $\frac{1}{2}$ -13  $\times$   $\frac{1}{4}$ -inch hex-head stainless steel cap screws, Belleville washers, and nuts furnished. See Figure 15.

Avoid excess tension or torque between the interrupter bus and the disconnect bus. If the holes between the two sections of buswork do not line up properly, loosen the hardware securing the interrupter mounting brackets to the disconnect base, and shift the interrupter until the holes are aligned. Retighten the interrupter hardware to a torque of 70 to 80 ft.-lbs. if necessary.

**⚠ WARNING**

**Never exceed the recommended torque limit.** The interrupter base is pressurized to 75 PSI. **Damage to the interrupter and personal injury can occur.**

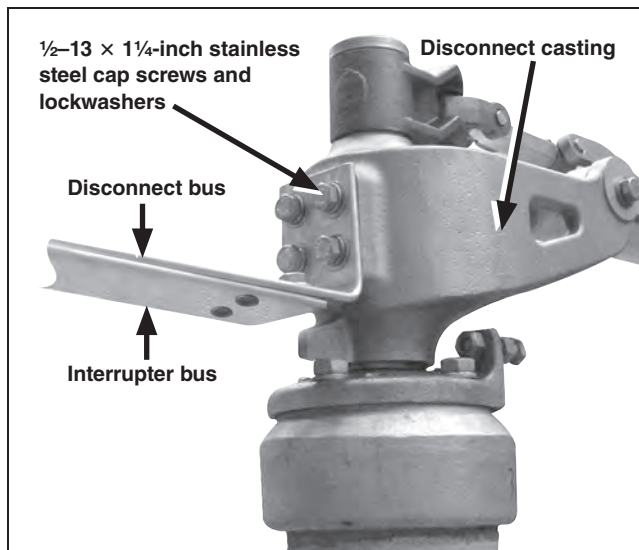

**Figure 14.** Attach the disconnect bus to the tapped holes in the disconnect casting. Overlap the interrupter bus.

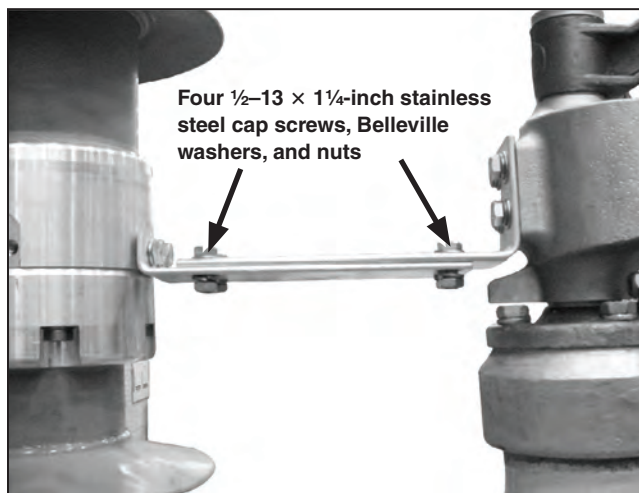

**Figure 15.** Attach the interrupter bus to the disconnect bus.

# Installation

## Checking the Operation of the Disconnect

Repeat Step 1 through Step 3 for each pole-unit.

**STEP 1.** Check operation of the blade using the following procedure:

- (a) Bolt the **TEMPORARY MANUAL OPERATING** handle to the disconnect drive-shaft crank. See Figure 16. Firmly crank the disconnect to its fully **Open** position. Visually check the disconnect blade opens to  $90^{\circ}$  to  $96^{\circ}$  from horizontal. See Figure 17.
- (b) If the blade does not open  $90^{\circ}$  to  $96^{\circ}$ , shim underneath the disconnect base as required to make up for any irregularities or distortion in the mounting surface.
- (c) Make sure the pole-unit base is level, and the interrupter is vertically aligned with the disconnect pole-unit insulators.

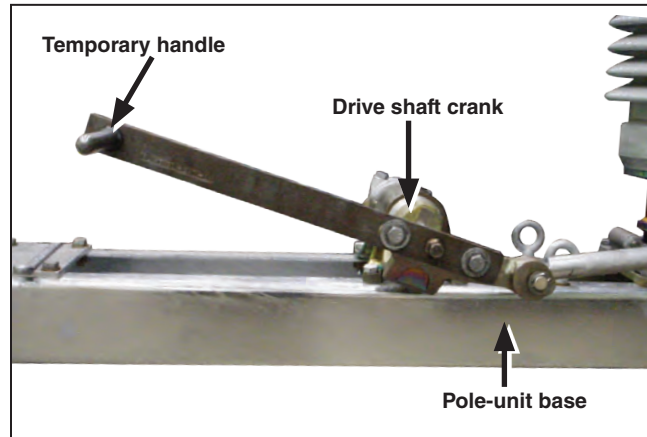

**Figure 16.** Attach the **TEMPORARY MANUAL OPERATING** handle to the drive-shaft crank.

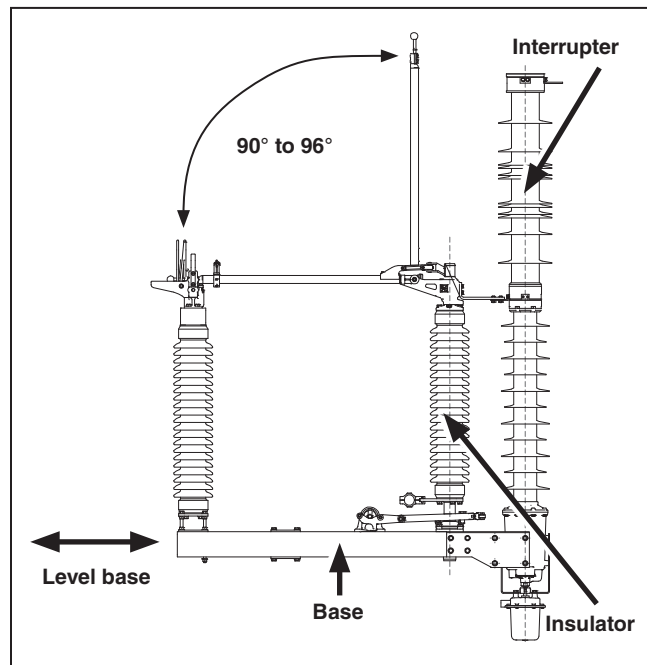

**Figure 17.** Check the angle of the disconnect blade.

**STEP 2.** Check operation of the blade for proper alignment of the blade with the jaw-contact assembly. As the blade is closed, the fault-closing tongue contact should engage each of the fault-closing jaw contacts with equal pressure and the current-carrying tongue contact should enter the current-carrying jaw contacts with equal clearance on each side.

The silver-surfaced area of the current-carrying tongue contacts should center laterally with the silver-surfaced current-carrying jaw contacts, and the blade should rotate with slight pressure against the blade bumper stop and come to rest either on the stop or slightly above it. See Figure 18.

**STEP 3.** Close the disconnect and remove the TEMPORARY MANUAL OPERATING handle.

#### NOTICE

If the blade angle is not attained or the contacts are not properly aligned after leveling the disconnect base, stop the installation and contact S&C Electric Company.

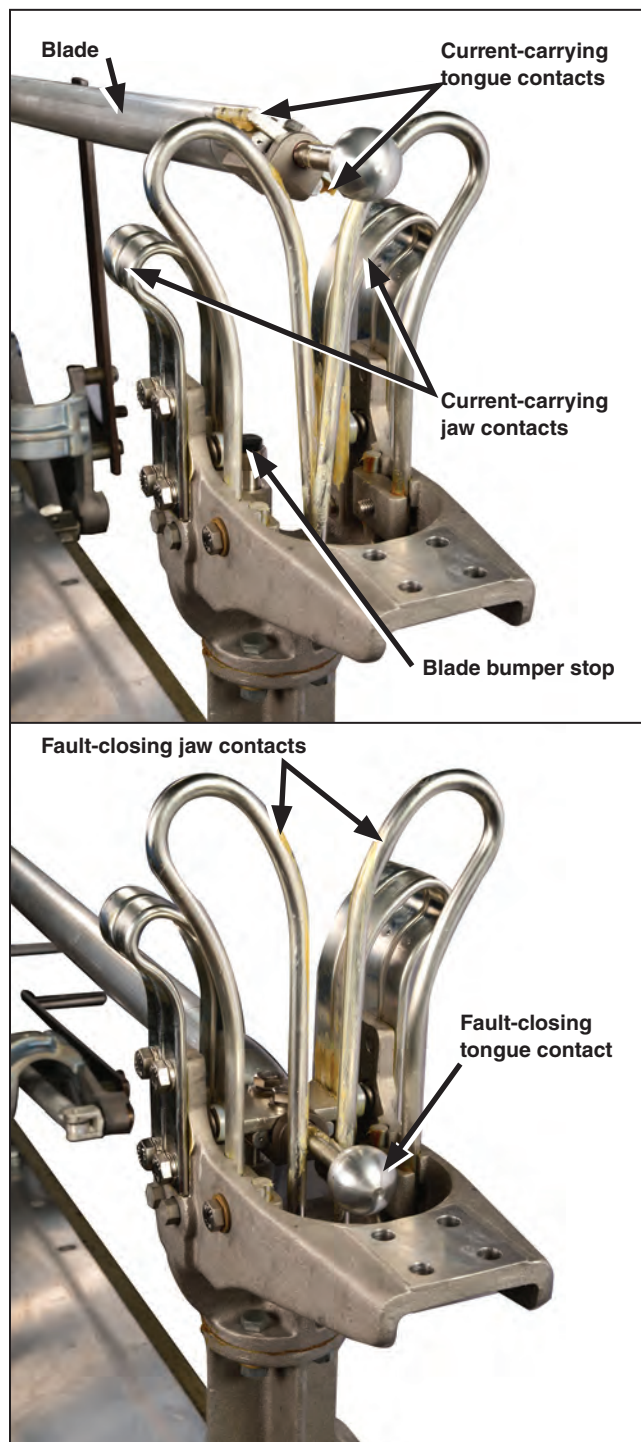

Figure 18. Check the penetration of the blade into the jaw contact during closing.

## Installing the Drive Train, Gearbox, and Interphase Shaft

The drive train comprises several sections of interphase shaft connecting the three pole-units to each other, a section of vertical operating shaft directly driven by the Mark VI CS-1A Switch Operator, and a gearbox connecting the vertical operating shaft to the interphase shaft. See Figure 19.

**STEP 1.** Before installing the interphase shaft sections, attach all flexible coupling assemblies to the disconnect drive shafts and the output end of the gearbox (if necessary) where indicated on the reference drawing.

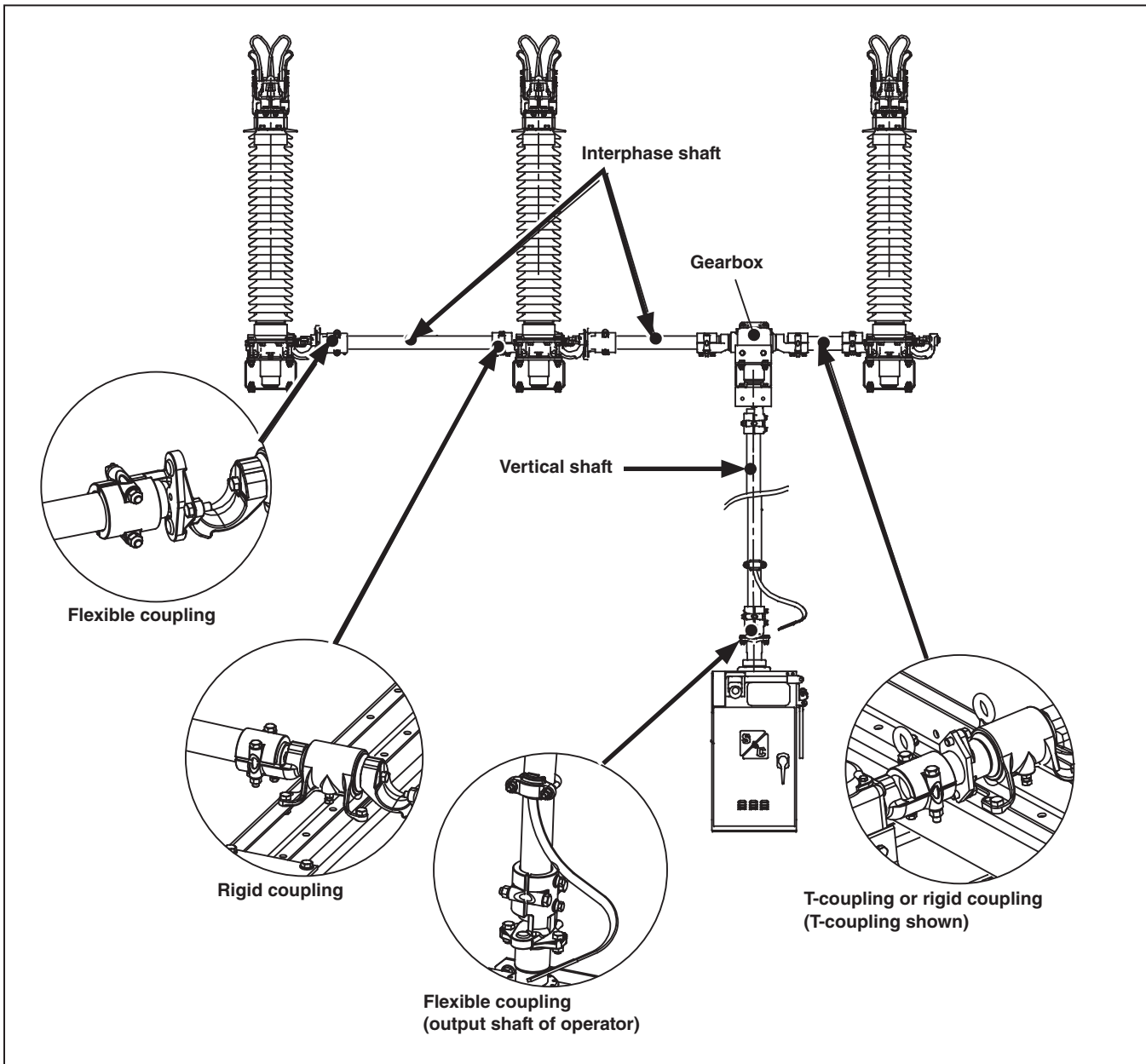

Figure 19. Drive train with coupling detail views.

**Note:** Rigid couplings to and from the gearbox are factory-installed to the gearbox. For some structures, a short flanged section of interphase shaft is provided to make the connections between the gearbox and the surrounding pole-units. Refer to the reference drawing for specific details on the interphase shaft arrangement. See Figure 19 on page 16 for a typical drive train arrangement.

- STEP 2.** Install the user-furnished gearbox support onto the user-furnished structure. If a detailed drawing of the user-furnished mounting structure was supplied when the switch was ordered, details of the gearbox support will be found on the associated erection drawing.

The gearbox support must hold the gearbox in a position so the rigid couplings on either side of the gearbox are level with the couplings on the pole-unit drive shafts. Use shims as required.

The gearbox must also be positioned so the vertical operating shaft from the operator makes the correct angle to the gearbox as shown on the reference drawing. (Flexible or universal couplings may be used at the input end of the gearbox. Check the reference drawing for details.)

- STEP 3.** Wrap appropriate lifting slings around the rigid couplings and the main body of the gearbox, and lift it into place on the gearbox support. See Figure 20. When properly installed, the arrow on the gearbox should face the direction indicated on the reference drawing.

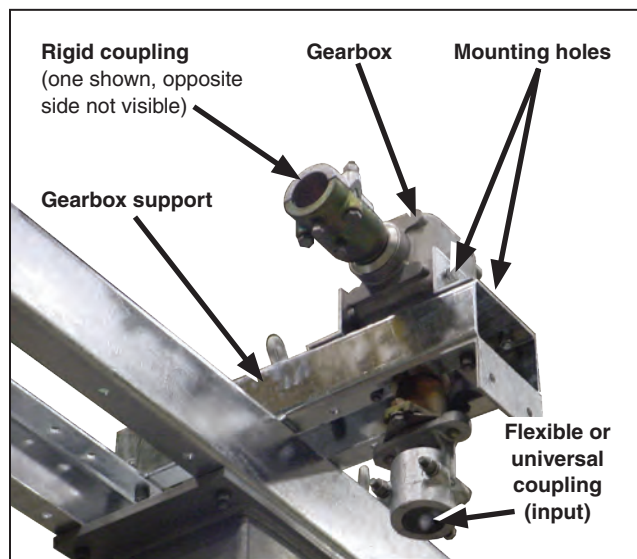

**Figure 20.** Install the gearbox.

## Installation

- STEP 4.** Using the ½–13-inch tapped mounting holes on the side of the gearbox, attach the gearbox to the structure or user-furnished gearbox support.
- STEP 5.** Attach the flexible coupling plate to the coupling flange on the disconnect using the following procedure:
- Thread the flexible coupling attachment bolts through the flexible coupling plate and through the coupling flange.
  - Tighten the bolts to draw the flexible plate flush against the flange; this will deform the threads in the flexible plate, resulting in a binding, nonslip connection.
  - Install and tighten the self-locking nuts. DO NOT use lockwashers with the flexible coupling attachment bolts. See Figure 21.
- STEP 6.** Before installing the interphase shaft, make sure the cutting tips of the piercing set screws do not protrude through the clamp.

With all pole-units in the **Closed** position, loosely fit the sections of interphase shaft between the appropriate coupling assemblies. Take care not to bring the switch “out of toggle” when fitting the shaft sections into the couplings. The interphase shaft should extend slightly past the flange end of the clamp. See Figure 22.

### NOTICE

Shaft sections are cut to the appropriate length at the factory. **Carefully examine and measure all sections of shaft before cutting any of the shaft sections.** The shaft sections can be trimmed using a pipe cutter.

Although the shaft sections are cut to the appropriate length at the factory, it may be necessary to cut them in the field. With the interphase shaft inserted into the coupling, tighten the clamp bolts equally so the clamp pulls down evenly on the coupling.

Tighten the piercing set screws, piercing the shaft, and continue turning until a firm resistance is felt. See Figure 23.

Continue connecting the remaining sections of interphase shaft.

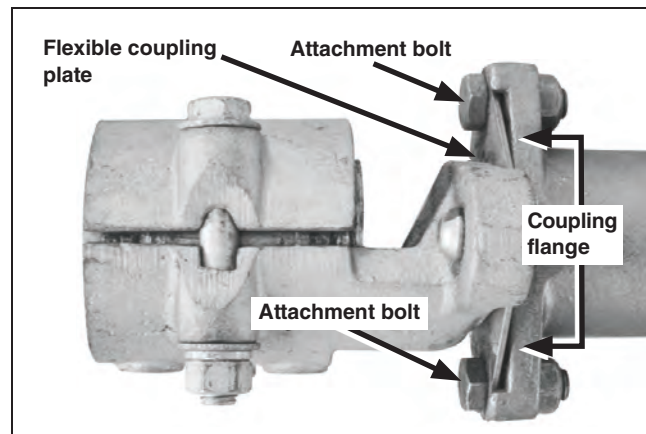

Figure 21. Attach the plate to the coupling flange.

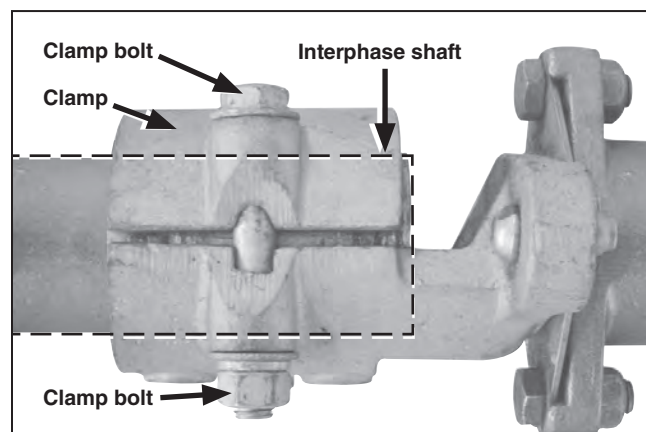

Figure 22. Insert the interphase shaft section between the couplings. Fasten the clamp to the couplings.

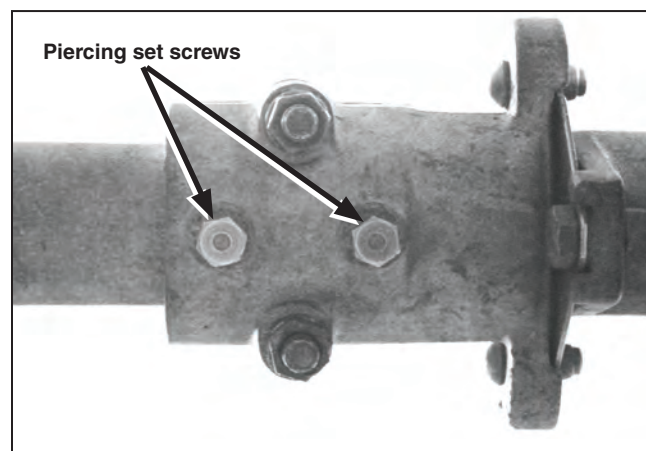

Figure 23. Tighten the piercing set screws.

## Installing the Mark VI CS-1A Switch Operator and Vertical Shaft

Mount the switch operator to the user-furnished structure as indicated on the erection drawing. The structure supporting the switch must meet the construction guidelines listed in S&C Information Bulletin 712-60.

### NOTICE

If more than one Mark VI CS-1A Switch Operator is available at the installation location, take care to select the one for this particular installation.

- STEP 1.** Unbolt the Mark VI CS-1A Switch Operator from its shipping skid.
- STEP 2.** Attach lifting slings around the output shaft of the Mark VI CS-1A Switch Operator. See Figure 24. Lift the operator into place on the user-furnished mounting structure. Avoid sudden starts and stops.
- STEP 3.** Align the upper and lower flanges on the rear of the operator with the user-furnished mounting surface provided on the structure. Fasten the operator to the structure using the  $\frac{5}{8}$ -inch holes provided on the mounting flanges, as shown in Figure 25. DO NOT remove the lifting slings from the operator until the operator is fully supported—using both flanges—by the structure.
- STEP 4.** Remove the lifting slings from the output shaft of the switch operator.

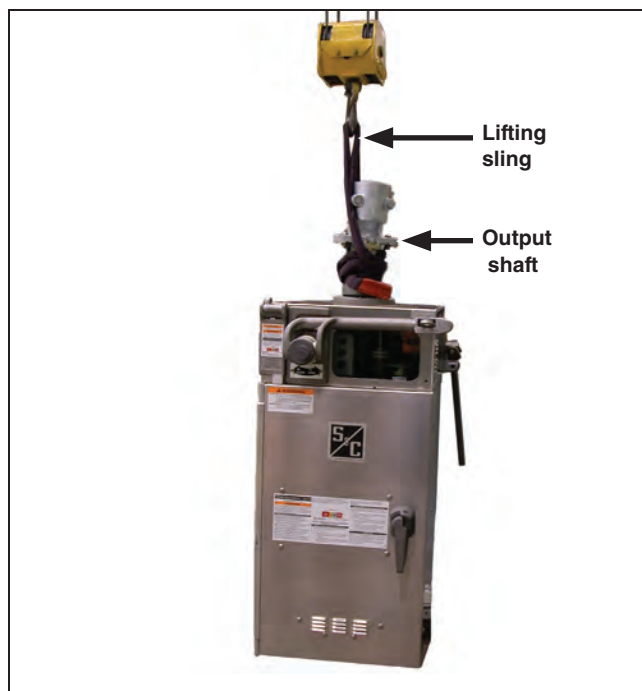

Figure 24. Attach the lifting sling to the output shaft.

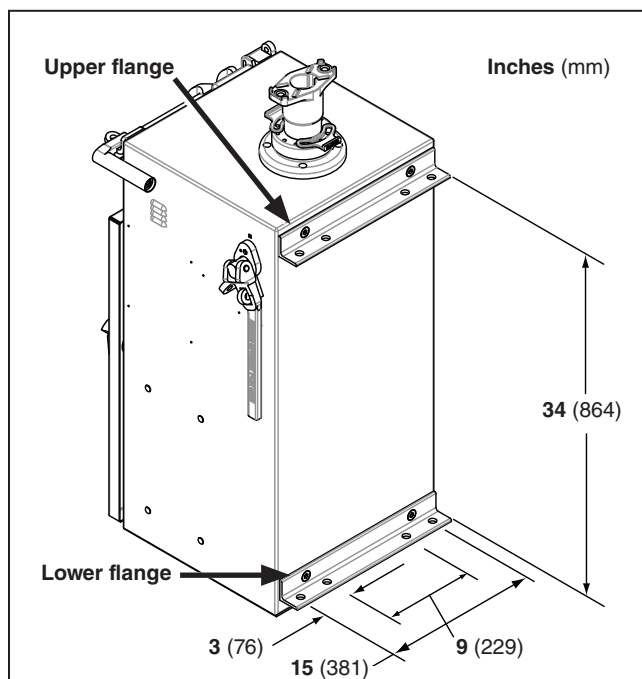

Figure 25. Attach the Mark VI CS-1A Switch Operator mounting flanges to the structure.

## Installation

**STEP 5.** The flexible couplings are pre-installed on the gearbox and Mark VI CS-1A Switch Operator. If required, attach the flexible coupling to the output shaft of the switch operator and to the input coupling of the gearbox using the following procedure:

### NOTICE

Make sure the cutting tips of the piercing set screws do not protrude through the body of the flexible coupling on the switch operator output shaft and the flexible coupling attached to the shaft extending from the gearbox.

- (a) Thread the flexible coupling attachment bolts through the flexible coupling plate and through the coupling flange.
- (b) Tighten the bolts to draw the flexible plate flush against the flange; this will deform the threads in the flexible plate, resulting in a binding, nonslip connection.
- (c) Install and tighten the self-locking nuts. Do not use lockwashers with the flexible coupling attachment bolts. See Figure 26.

If universal couplings are specified on the catalog drawing instead of flexible couplings, use the same installation procedure.

**STEP 6.** Before installing the vertical shaft, make sure the cutting tips of the piercing set screws do not protrude through the clamp.

Loosely fit the vertical shaft section between the gearbox and operator coupling assemblies. The vertical shaft should extend slightly past the flange end of each clamp. See Figure 27. If the shaft does not seat correctly or is too long or short, re-check the mounting height of the Mark VI CS-1A Switch Operator and re-adjust if necessary.

### NOTICE

Shaft sections are cut to the appropriate length at the factory. **Carefully examine and measure all sections of shaft before cutting any of the shaft sections.** The shaft sections can be trimmed using a pipe cutter.

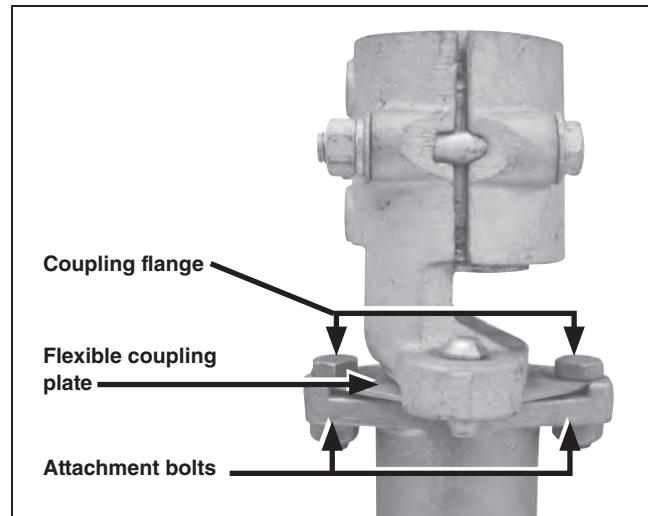

Figure 26. Attach the plate to the output shaft flange.

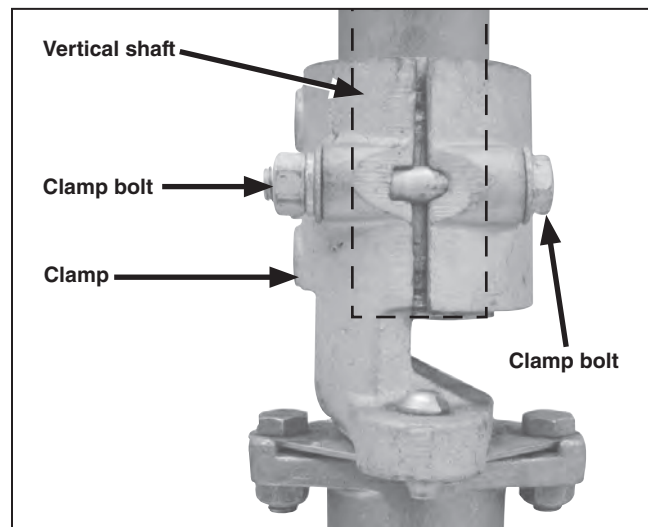

Figure 27. Insert the vertical shaft sections between the couplings. Fasten the clamp to the couplings.

**STEP 7.** With the vertical shaft inserted into the couplings, tighten the clamp bolts equally so the clamp pulls down evenly on the couplings.

When the vertical shaft is seated properly in both the gearbox and operator couplings, tighten the piercing set screws, piercing the shaft, and continue turning until a firm resistance is felt. See Figure 28.

**STEP 8.** Fasten the free end of the grounding strap to the vertical shaft a few inches above the flexible coupling attached to the switch operator, using the grounding connector provided. Then, fasten the other end of the grounding strap to a suitable earth ground. See Figure 29.

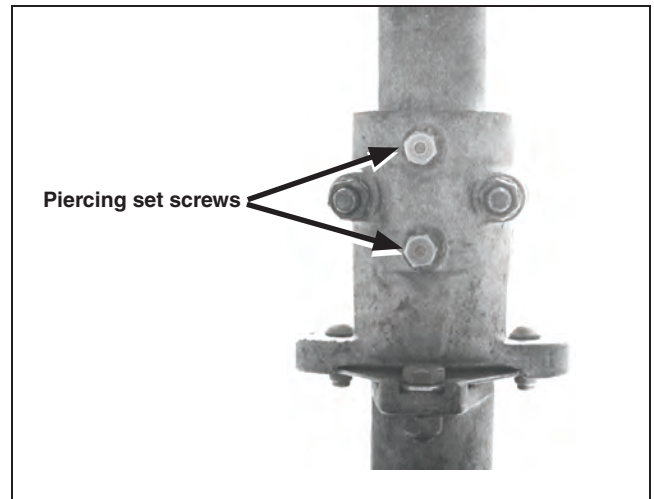

Figure 28. Tighten the piercing set screws.

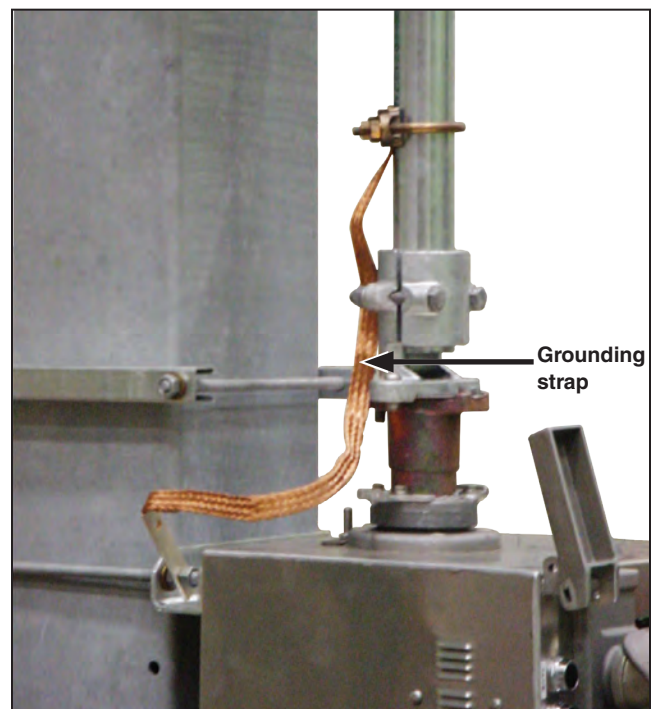

Figure 29. Attach the grounding strap.

## Installation

### Installing the Interrupter Charging Motors

Repeat Step 1 through Step 3 on page 23 for each interrupter.

#### NOTICE

The charging motors are factory-wired to use 48-Vdc, 125-Vdc, or 115-Vac control voltage. Motor control voltage cannot be changed in the field. Make sure the motors are the correct voltage for the installation.

- STEP 1.** Manually rotate the operating shaft counter-clockwise approximately  $\frac{1}{4}$ -turn until it is centered, as shown in Figure 30. The operating shaft pin should be parallel to the pole-unit base.
- STEP 2.** Locate the four mounting bosses on the top of the motor. See Figure 31. Align the mounting bosses with the holes in the motor brackets. Rotate the headhook if necessary.

***If the holes do not align:*** Loosen the studs supporting the motor brackets, and shift them until proper alignment is achieved.

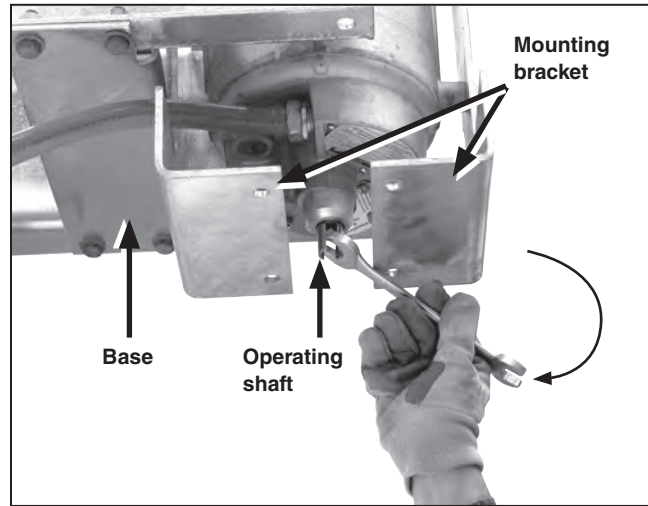

Figure 30. Rotate the operating shaft until it is centered.

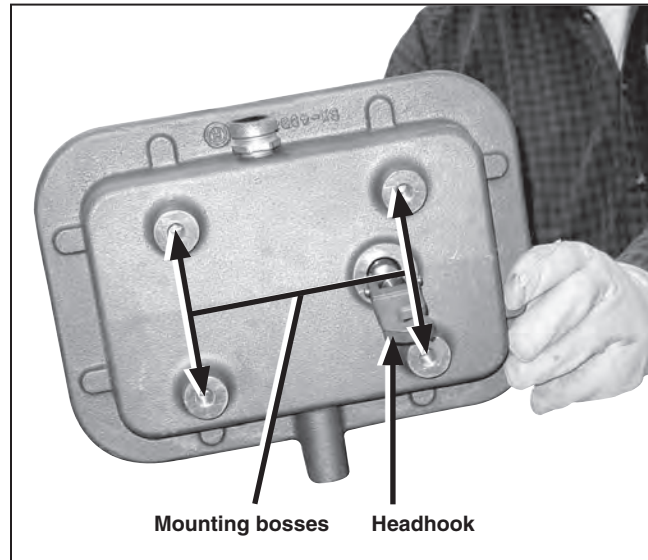

Figure 31. Charging motor mounting bosses.

**STEP 3.** Hook the headhook onto the operating shaft pin. The headhook should hang securely from the operating shaft. Turn the motor until the mounting bosses align with the holes in the mounting brackets. See Figure 32. Using the four  $\frac{1}{2}$ -13  $\times$   $1\frac{1}{4}$ -inch stainless steel hex-head cap screws and flat washers furnished, fasten the motor to the brackets. Tighten the screws to between 40 and 50 ft.-lbs. See Figure 33.

If engaging the headhook with the operating shaft is difficult, turn the operating shaft counterclockwise until it stops, approximately one to four turns. Then, turn the shaft clockwise  $\frac{1}{4}$ -turn. The headhook should engage easily with the operating shaft.

Retighten any of the nuts loosened in Step 2 on page 22.

**⚠ WARNING**

**Never exceed the recommended torque limit.** The interrupter base is pressurized to 75 PSI. **Damage to the interrupter and personal injury can occur.**

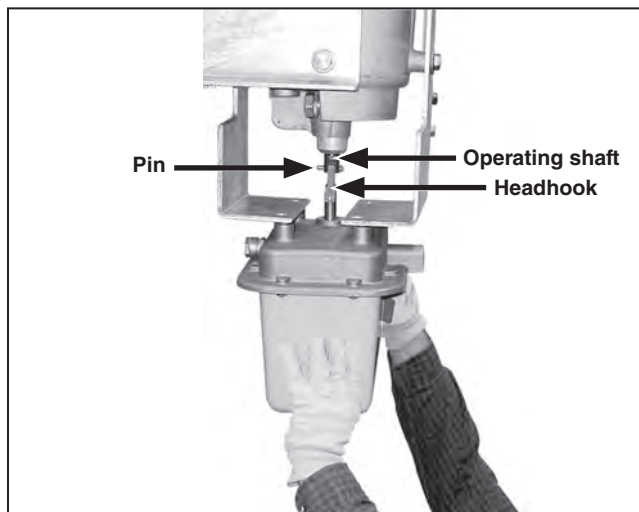

Figure 32. Attach the motor to the operating shaft.

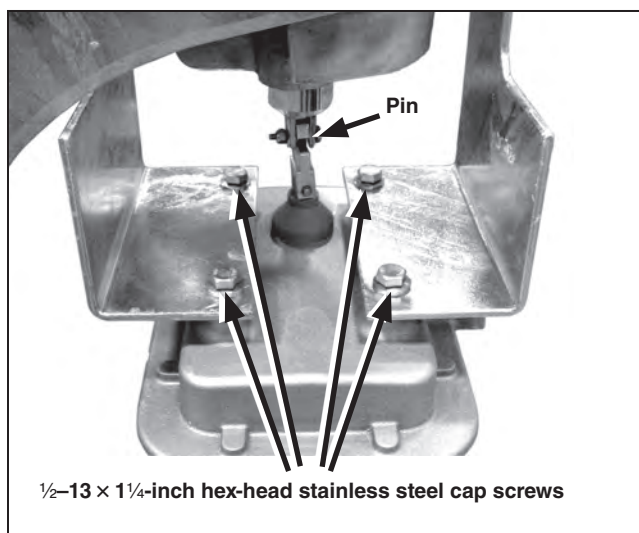

Figure 33. Secure the motor to the motor brackets.

# Installation

## Installing the User-Furnished Conduit

### NOTICE

Keep conduit and conduit hangers clear of the drive train. Do not attach the conduit assembly to the interphase or vertical operating shaft, and do not attach conduit to any moving parts of the circuit-switcher. Damage to the circuit-switcher can occur.

Prepare sections of conduit to connect the 3/4-14 NPT conduit tap on each interrupter junction box to the 1/2-14 NPT conduit tap on the associated charging motor, along with the entrance plate of the Mark VI CS-1A Switch Operator. See Figure 34 and Figure 35. Refer to S&C Information Bulletin 712-60 for wire specifications. Refer to the wiring diagram and erection drawing for required conduit length and placement. Refer to the conduit manufacturer's recommendations for sealing and joining conduit sections.

### NOTICE

If S&C-supplied pre-wired conduit has been furnished with the Mark VI Circuit-Switcher, refer to the erection drawing for details on the conduit placement.

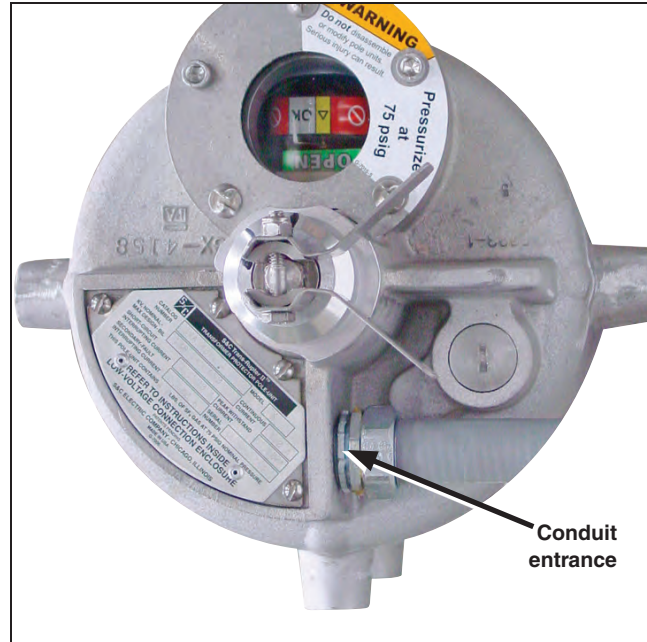

Figure 34. Connect conduit to the interrupter junction box.

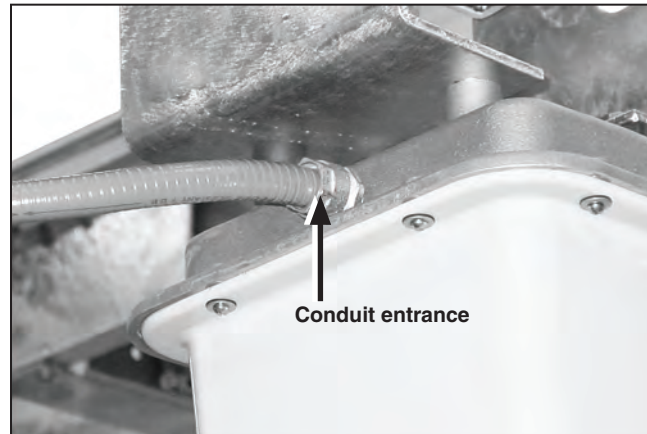

Figure 35. Make the conduit connection between the charging motor and the Mark VI CS-1A Switch Operator.

### Wiring the Interrupters and Charging Motors

Repeat Step 1 through Step 7 on page 26 for each interrupter and charging motor.

**⚠ WARNING**

**DO NOT** remove the window bolts on the interrupter. The interrupter is pressurized to 75 PSIG. **Serious injury could occur.**

**STEP 1.** Remove the outer motor bracket. Retain the hardware. Remove the three removable screws of the interrupter electrical junction box cover. Retain the hardware. Loosen the fourth retaining screw. Swing out the cover to access the wiring inside the electrical junction box. See Figure 36 through Figure 38.

**STEP 2.** Following the wiring diagram furnished, connect the conduit wiring to the wiring inside the electrical junction box. Use the butt splices supplied with the junction-box wiring. The butt splices accommodate 18 to 22 AWG wire.

**NOTICE**

To ensure proper crimping of the butt splices, use a Panduit controlled-cycle hand tool (CT-1550) or a similar tool for attaching 18- to 20-gauge insulated ring lugs.

**STEP 3.** Rotate the cover of the electrical junction box and replace the retained screws. See Figure 37. Securely tighten all screws. Reinstall the motor bracket removed in Step 1. Torque the removed 5/8-inch stud nuts to between 70 and 80 ft.-lbs. See Figure 36.

**NOTICE**

When inserting the connected wires in the electrical junction box make sure no wires are pinched underneath the junction box cover. Trim excessive wire length from the interrupter's electrical junction box wiring before installation, if necessary.

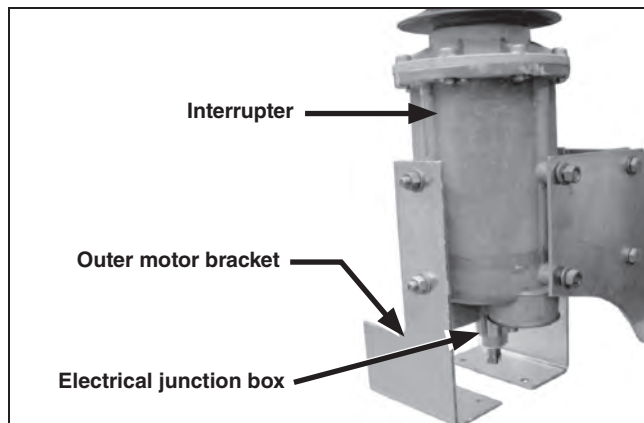

Figure 36. Temporarily remove the motor bracket.

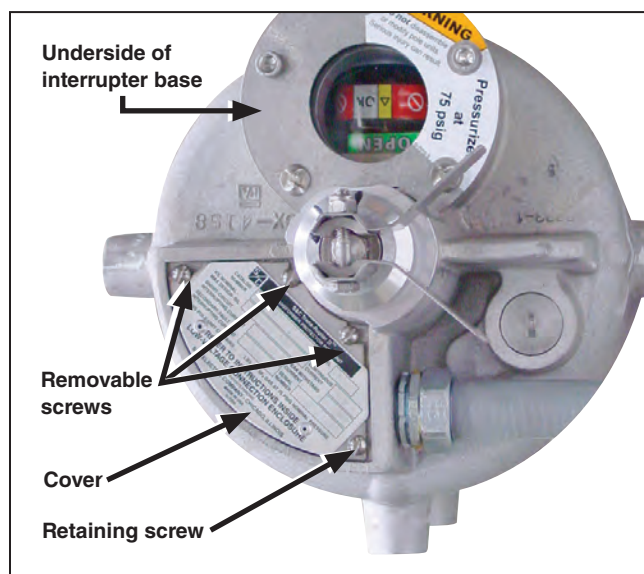

Figure 37. Remove the three removable screws from the interrupter electrical junction box cover. Loosen but do not remove the fourth screw.

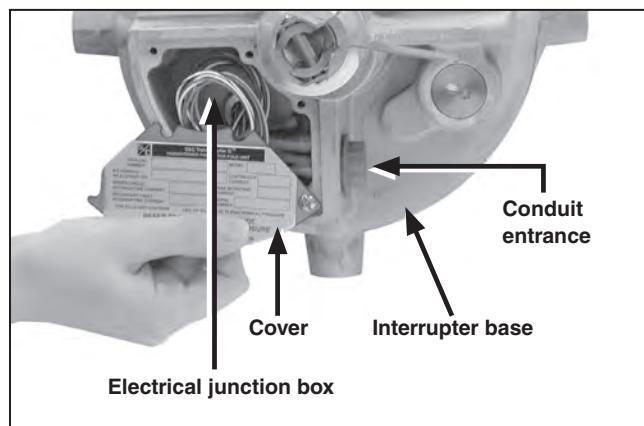

Figure 38. Swing out the cover to access the wiring inside the electrical junction box.

## Installation

**STEP 4.** Remove and retain the eight 10-32×<sup>5</sup>/<sub>8</sub>-inch stainless steel round-head machine screws securing the motor cover to the motor housing. Remove the motor cover, and set the cover and screws aside in a protected area. See Figure 39.

**STEP 5.** Connect the conduit to the ½-14 NPT tap on the side of the motor housing, and pull the wires through into the motor housing. Use watertight fittings to make all connections. See Figure 40.

**STEP 6.** Following the supplied wiring diagram, make the necessary wiring connections to the terminal block in the motor operator. See Figure 41.

DO NOT remove the jumper between Terminals 8 and 9. Train the motor wiring toward the center of the housing so the motor wiring does not come in contact with the motor cover. Bend the terminal lugs if necessary.

### NOTICE

If control power is lost while the Mark VI Circuit-Switcher interrupter charging motors are closing and charging the pole-units, the jumper between Terminals 8 and 9 will force the motor operators to “reset” to the beginning of their charging cycle when control power is restored.

**STEP 7.** Replace the motor cover and secure it using the screws retained from Step 4.

### NOTICE

**DO NOT** connect the wiring from the Mark VI CS-1A Switch Operator at this time. Keep the wiring clear of any moving parts inside the operator.



Figure 39. Remove the motor cover.

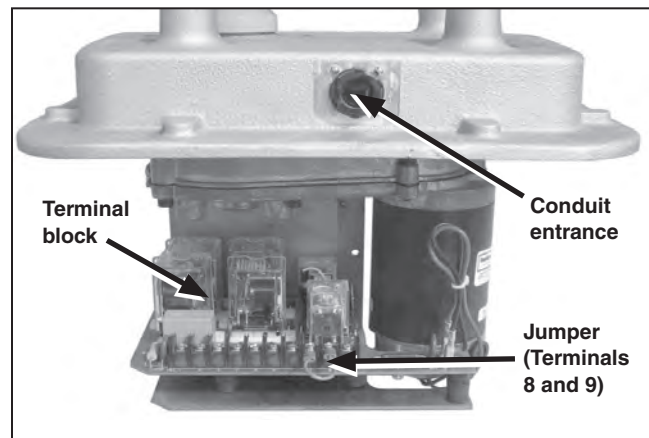

Figure 40. Bring conduit through the entrance into the motor housing. Do not remove the jumper.

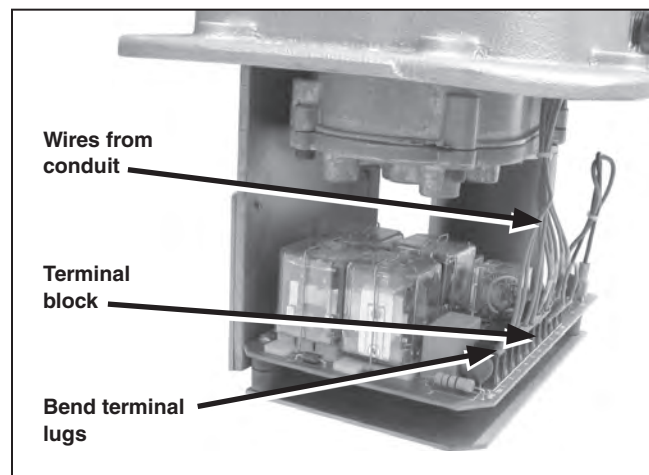

Figure 41. Connect wiring to the terminals per the supplied wiring diagram. Train the wires away from the edge of the motor housing to allow clearance between the wires and the motor cover. Bend the terminal wire lugs if necessary.

### Before Starting

Make sure the Mark VI CS-1A Switch Operator is securely attached to the structure and the vertical shaft is attached to the coupling on the output shaft of the switch operator.

The factory-installed jumpers should be in place between the interrupter contacts. See Figure 42.

#### NOTICE

**DO NOT** remove the jumpers until directed to do so in the following instructions. **DO NOT** wire the interrupters and charging motors to the Mark VI CS-1A Switch Operator until directed to do so in the following instructions.

Two tagged temporary jumpers have been installed inside the Mark VI CS-1A Switch Operator between the interrupter “a” contacts and the “b” contacts. These jumpers bypass the interrupter trip solenoids, allowing adjustment and checkout of the operator before the interrupters and charging motors are wired into the circuit. (The charging motors take two minutes to close and reset the interrupters between operations.)

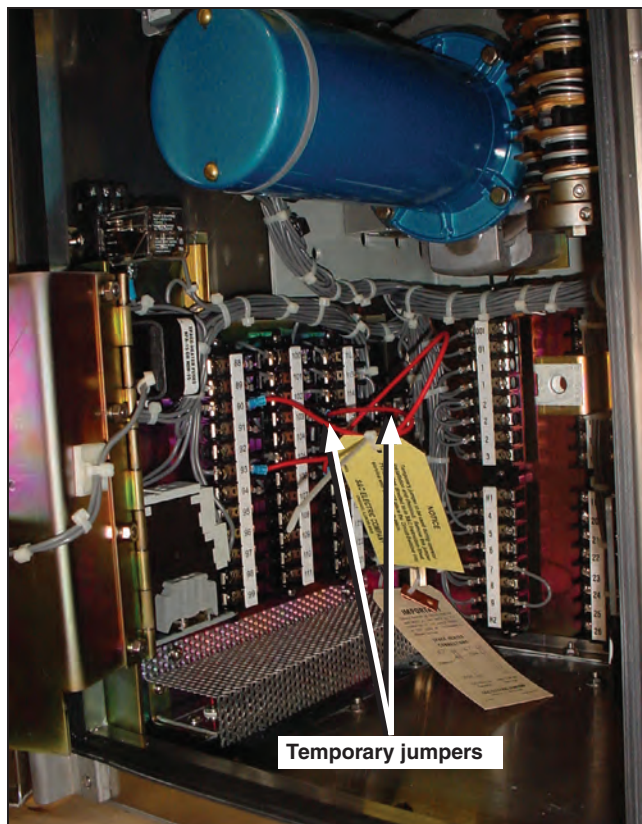

Figure 42. Location of temporary jumpers.

## Connecting Control Power and User-Furnished Control Circuits

**STEP 1.** Mark the conduit entrance location for the control-circuit and control-power wiring on the conduit entrance plate at the bottom of the switch operator enclosure. See Figure 43. Remove the conduit entrance plate and cut out the necessary openings.

Replace the conduit entrance plate and make up the entrance fittings. Apply the provided sealing compound when replacing the conduit entrance plate. Verify the conduit entrance fittings are properly sealed to prevent water ingress.

### NOTICE

To avoid accidental energizing of the operator after the external connections have been completed, remove the two-pole pull-out fuseholders for the motor and space heater. See Figure 43. **Reinsert the fuseholder only when indicated in the following steps.**

**STEP 2.** Remove the labels and blocking tape from the motor contactors. See Figure 44.

### NOTICE

Do not connect the wiring from the interrupters or interrupter charging motors at this time. Complete the installation and testing of the control circuit wiring before wiring the interrupters and charging motors. The charging motors take approximately two minutes to close and charge the interrupters.

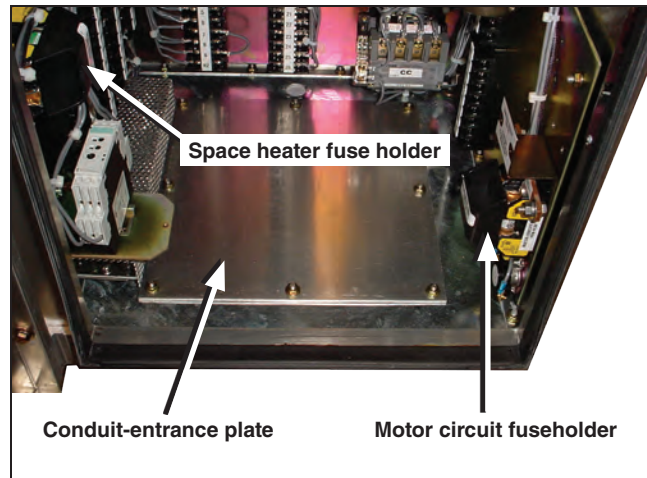

Figure 43. The conduit entrance plate.

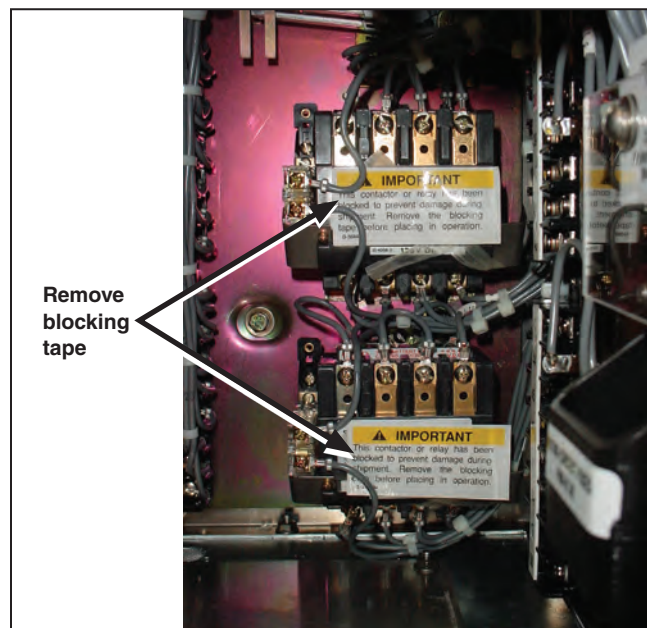

Figure 44. Remove the blocking from the motor contactors.

**STEP 3.** Connect the external control-circuit wiring (including space-heater source leads) to the terminal blocks of the switch operator in accordance with the wiring diagram furnished. See Figure 45.

**CAUTION**

Unauthorized changes should not be made in the wiring of this switch operator. Should a control-circuit revision appear desirable, it should be made only on the authority of a revised wiring diagram approved by both the user and S&C Electric Company. Incorrect wiring can cause damage to the operator and may cause minor electrical shock.

**NOTICE**

Observe recommended minimum wire-size requirements for the control-circuit wiring, as shown in Information Bulletin 712-60 and on the switch operator schematic wiring diagram furnished. Wiring must be complete, and adequate control voltage must be available at the switch operator before checkout.

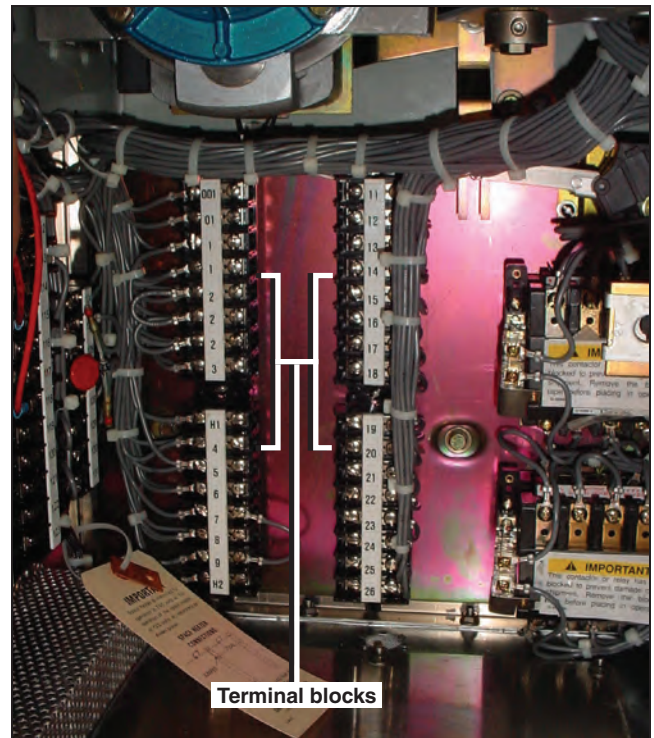

Figure 45. Connect the external control-circuit wiring.

## Wiring and Adjusting the Switch Operator

### Using the Manual Operating Handle

Before proceeding, become familiar with the operation of the MANUAL OPERATING handle.

#### **WARNING**

Do not operate the Mark VI Circuit-Switcher with the MANUAL OPERATING handle while the switch is energized. The MANUAL OPERATING handle should only be used during installation and checkout of the switch. **Manual operation of an energized Mark VI Circuit-Switcher could, in the event of a fault or loss of control power to the operator, cause serious injury or death as well as damage to the circuit-switcher.**

**Note:** The MANUAL OPERATING handle should only be used during installation, checkout, and inspection of the circuit-switcher.

#### **NOTICE**

The MANUAL OPERATING handle may be disengaged from the switch operator mechanism in any position. The handle may be padlocked in its **Storage** position.

#### **To operate:**

- STEP 1.** Pull the latch knob on the hub of the MANUAL OPERATING handle and pivot the handle forward slightly from its **Storage** position.
- STEP 2.** Release the latch knob while continuing to pivot the handle forward to lock it into the **Cranking** position. See Figure 46. (As the handle is pivoted forward, the motor brake is mechanically released, both leads of the control source are automatically disconnected, and both the “opening” and “closing” motor contactors are mechanically blocked in the **Open** position.)
- STEP 3.** The disconnect can be opened and closed by cranking the handle clockwise or counterclockwise, respectively.

#### **To return the MANUAL OPERATING handle to its storage position:**

- STEP 1.** Pull the latch knob and pivot the handle approximately 90°. The handle will disengage from the switch operator and may be rotated freely in either direction.
- STEP 2.** Complete handle storage by pivoting the operating handle backward approximately 90° until it latches in the **Storage** position.

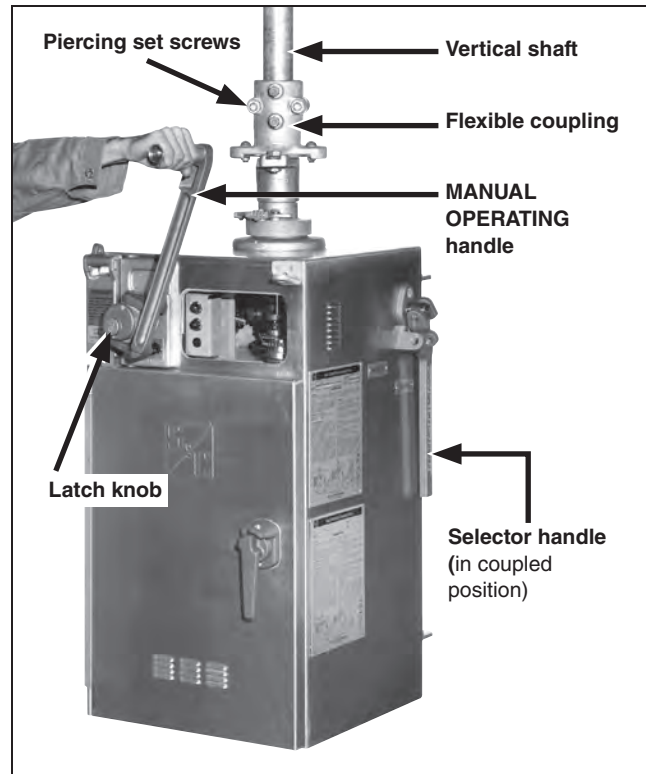

Figure 46. Manually operating the disconnect with the MANUAL OPERATING handle.

## Using the Selector Handle (Coupling and Decoupling)

The SELECTOR handle is used to couple and decouple the motor from the operating shaft. Decoupling the motor allows the user to install and configure control schemes and inspect the operation of the motor without opening and closing the disconnect.

The integral external SELECTOR handle, for operation of the built-in internal decoupling mechanism, is located on the right-hand side of the switch operator enclosure. See Figure 47.

### To decouple:

- STEP 1.** Swing the SELECTOR handle upright and slowly rotate it clockwise 50° to the **Decoupled** position. See Figure 47.
- STEP 2.** Lower the SELECTOR handle to engage the locking tab.
- Note:** The switch operator may be operated either manually or electrically without operating the disconnect. Moreover, in the **Decoupled** position, the switch operator output shaft is prevented from moving by a mechanical locking device located within the switch operator enclosure. During the intermediate segment of the SELECTOR handle travel, including the position at which actual disengagement (or engagement) of the internal decoupling mechanism occurs, the motor-circuit source leads are momentarily disconnected and both the opening and closing motor contactors are mechanically blocked in the **Open** position.
- STEP 3.** Look through the observation window and verify the internal decoupling mechanism is in the **Decoupled** position. See Figure 48.

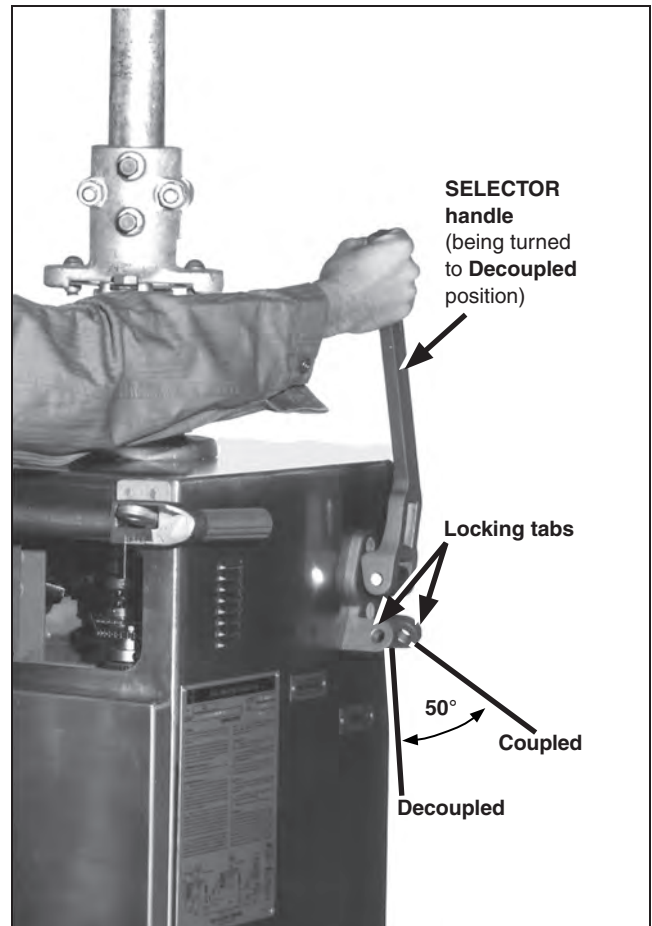

Figure 47. Selector handle operation.

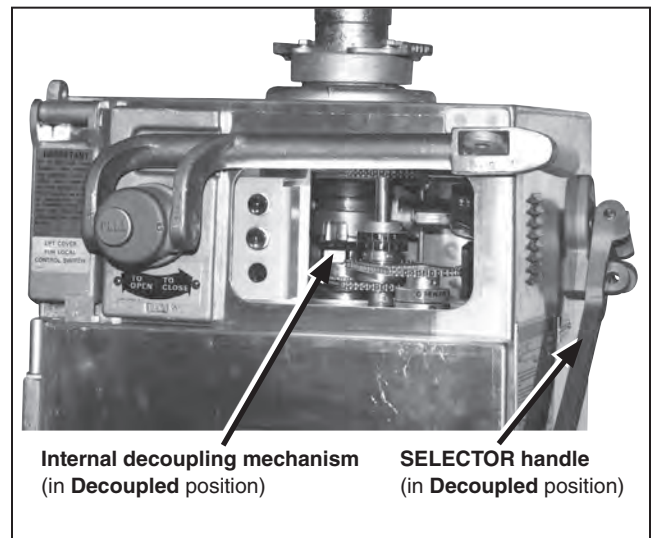

Figure 48. Verify the switch operator is decoupled.

## Wiring and Adjusting the Switch Operator

### To couple:

- STEP 1.** Manually operate the MANUAL OPERATING handle to bring the disconnect to the same position (**Open** or **Closed**) as the Mark VI CS-1A Switch Operator. The switch operator position indicator, seen through the observation window, will show when the approximate **Open** or **Closed** position has been attained. (The position indicator for the disconnect, located on the output-shaft collar of the switch operator, will be aligned later.)
- STEP 2.** Turn the MANUAL OPERATING handle slowly until the position-indexing drums are numerically aligned.
- STEP 3.** Swing the SELECTOR handle upright and rotate it counterclockwise to the **Coupled** position.
- STEP 4.** Lower the handle to engage the locking tab. Verify the switch is **Coupled**. See Figure 49.

### NOTICE

The SELECTOR handle may be padlocked in either position.

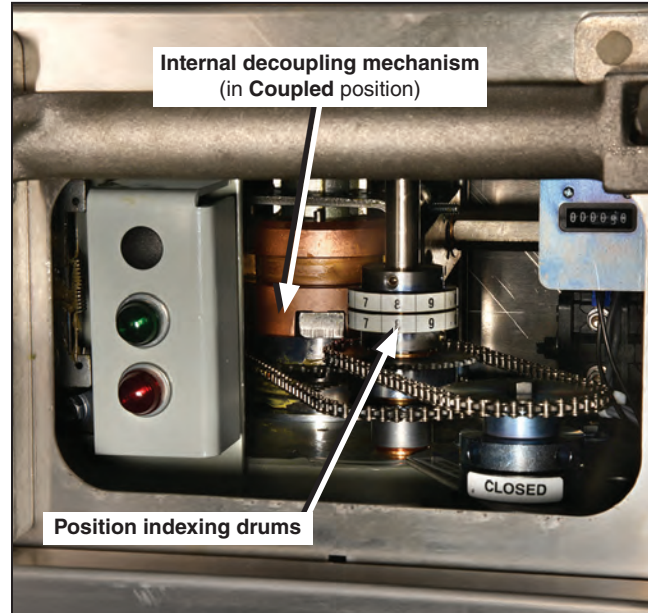

Figure 49. Verify the switch operator is coupled.

## Adjusting the Switch Operator

### NOTICE

To avoid accidentally energizing the operator, remove the two-pole pull-out fuseholders for the motor and space heater and do not reinsert them until so directed.

To adjust the switch operator, complete the following steps:

- STEP 1.** Manually operate the disconnect to bring it to the same position (fully **Open** or fully **Closed**) as the Mark VI CS-1A Switch Operator.
- STEP 2.** Tighten the flexible coupling clamp bolts on the output shaft of the operator equally so the clamp pulls down evenly. Then, tighten the associated piercing set screws, piercing the shaft, and continue turning until a firm resistance is felt. See Figure 50.
- STEP 3.** With the SELECTOR handle in the **Coupled** position, crank the disconnect to the fully **Open** position and then accurately align the disconnect position indicators on the output-shaft collar of the switch operator with the alignment arrow below. See Figure 51.
- STEP 4.** Make sure the drive-shaft crank of each pole-unit is in an **Overtoggle** position and against its Open or Closed stop at the fully **Open** or fully **Closed** position of the switch operator.

### CAUTION

Avoid forcing the power train beyond the fully Open or fully Closed stop positions. Forced cranking against these stops can build up sufficient spring energy in the vertical and interphase shafts to cause the MANUAL OPERATING handle to spin backwards if the grasp on the handle is accidentally released, causing minor injury.

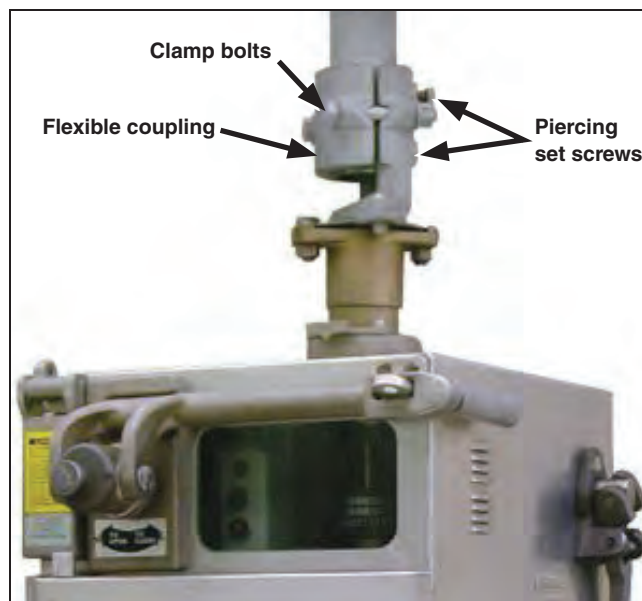

Figure 50. Tighten the flexible coupling on the operator output shaft. Tighten the piercing set screws.

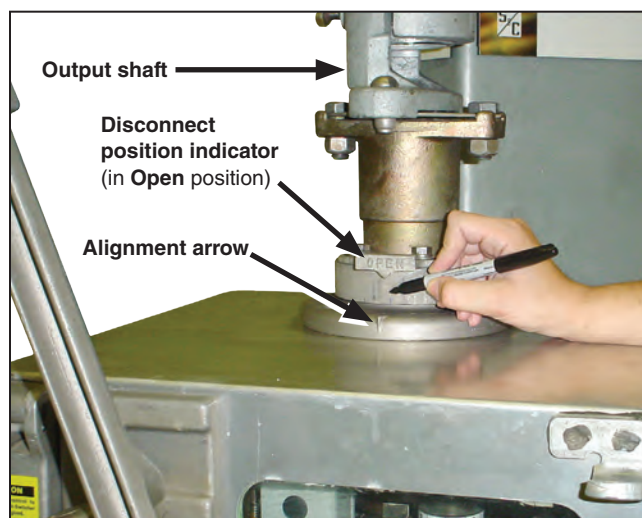

Figure 51. Align the position indicators. Mark the direction of rotation of the output shaft.

## Wiring and Adjusting the Switch Operator

**STEP 5.** Verify the directions of rotation are correct as follows:

### NOTICE

The cranking direction to close the disconnect is indicated by an arrow plate located near the hub of the MANUAL OPERATING handle and is set at the factory. Do not attempt to adjust the motor direction or cranking direction without first consulting S&C Electric Company.

- (a) With the SELECTOR handle in the **Coupled** position, manually crank the disconnect to the fully **Open** position and then to the fully **Closed** position. Temporarily mark on the top of the switch operator enclosure the direction in which the output shaft rotates to close the disconnect. See Figure 51 on page 33.
- (b) If the cranking direction required to close the circuit-switcher is opposite to that indicated by the arrow plate, remove the arrow-plate mounting screws and remount the arrow plate, exposing the other side. See Figure 52.
- (c) With the MANUAL OPERATING handle in its **Storage** position and the SELECTOR handle in the **Decoupled** position, reinsert the motor-circuit fuseholder. Open the pushbutton protective cover●, and operate the switch operator by means of the externally mounted OPEN/CLOSE pushbuttons, if provided, or in their absence, by momentarily jumpering Terminals 1 and 8 to open, and 1 and 9 to close.

### NOTICE

Terminal designations may differ in special wiring diagrams. In such cases, refer to the specific wiring diagram for correct terminal designations.

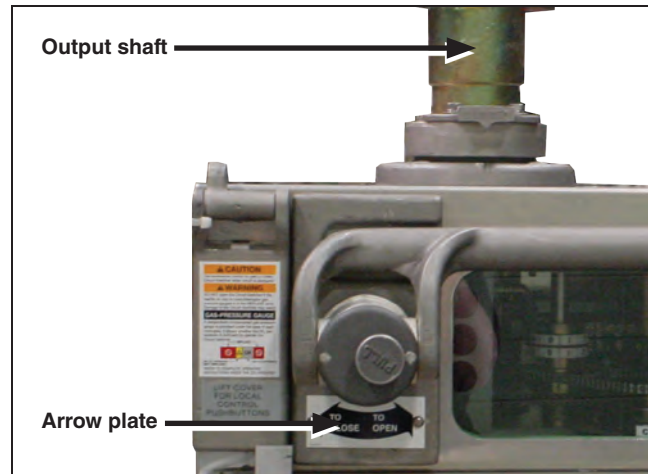

**Figure 52.** Verify the direction of the output shaft rotation matches the direction indicated by the arrow plate.

● For a switch operator with optional REMOTE-CONTROL BLOCKING switch (catalog number suffix “-Y”), opening the pushbutton protective cover prevents remote operation of the switch operator.

**Note:** The direction in which the travel-limit discs rotate when the switch operator closes should agree with the temporary direction mark on the top of the enclosure and with the direction displayed in the cutaway section on the outer ring of the travel-limit discs. See Figure 53 and Figure 54.

**STEP 6.** Verify the direction of rotation of the travel-limit discs is always the same as the direction of rotation of the output shaft:

- (a) ***If the direction of rotation of the travel-limit discs noted in Step 5 on page 34 is opposite to the temporary direction mark, a reversal of the motor direction will be necessary:***

Remove the motor-circuit fuseholder to avoid accidentally energizing the control circuit. Interchange the “-S1” and “-S2” motor leads connected to Terminals 4 and 5. Reversal for the motor direction reverses only the direction of the rotation of the output shaft and travel-limit discs. The identity of the opening-stroke and closing-stroke travel-limit discs (which will be adjusted later) is unaffected.

***If the direction of rotation of the travel-limit discs noted in Step 5 on page 34 is opposite to the direction displayed in the cutaway section on the outer ring of the closing-stroke travel-limit disc:*** Remove the positioning screws on the outer ring of the closing-stroke travel-limit disc. See Figure 54. Rotate the outer ring until the desired direction is displayed in the cutaway section. Replace the positioning screws.

- (b) Reinsert the motor-circuit fuseholder and electrically operate the switch operator to the **Open** position.
- (c) ***If the direction of output-shaft rotation to open the disconnect is opposite to that displayed in the cutaway section on the outer ring of the opening-stroke travel-limit disc:*** Remove the positioning screws on the outer ring of the opening-stroke travel-limit disc. See Figure 53. Rotate the outer ring until the desired direction is displayed in the cutaway section. Replace the positioning screws.

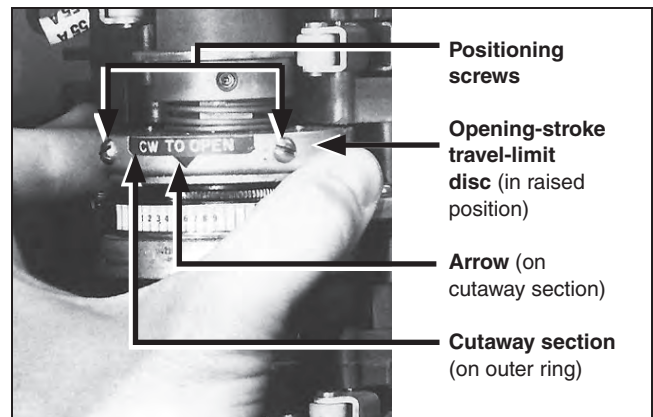

**Figure 53.** Make sure the cutaway section indicates the correct direction of rotation (opening-stroke disc).

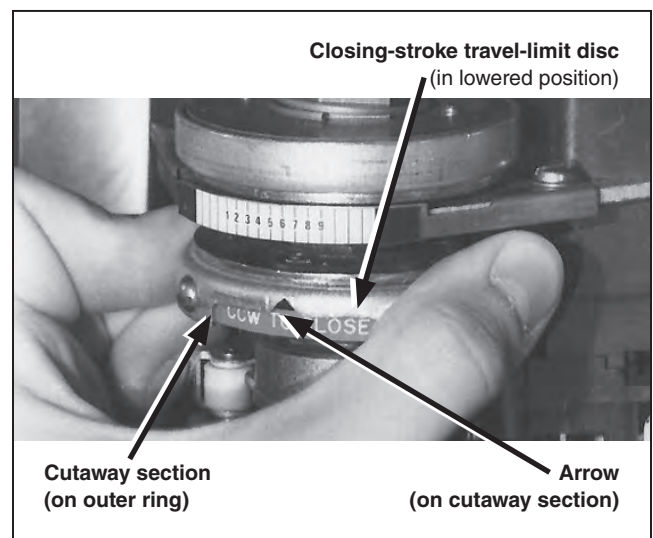

**Figure 54.** Make sure the cutaway section indicates the correct direction of rotation (closing-stroke disc).

## Wiring and Adjusting the Switch Operator

**STEP 7.** The travel-limit switch governing the extent of output-shaft rotation in the opening and closing directions includes six contacts operated by cam-actuated rollers. Positioning of the cams to properly engage the rollers is facilitated by the travel-limit discs (upper one is the opening-stroke travel-limit disc; lower one is the closing-stroke travel-limit disc).

**Adjust the opening-stroke travel-limit as follows:**

- (a) Remove the motor-circuit fuseholder.
- (b) Place the SELECTOR handle in the **Coupled** position and manually crank the disconnect to the **Open** position.
- (c) Before rotating the limit disc, from Table 1 on page 37, select the indicator-plate number from the “Opening-Stroke Adjustment—Clockwise to Open” column if the disc and output shaft rotate in the clockwise direction to open disconnect, or from the “Opening-Stroke Adjustment—Counterclockwise to Open” column if the disc and output shaft rotate in the counterclockwise direction to open the disconnect.
- (d) Grasp the handwheel and turn it to the extent possible in a direction opposite to

the direction the output shaft rotates to open the disconnect. See Figure 55.

- (e) With the handwheel held in the position indicated, raise the opening-stroke travel-limit disc approximately  $\frac{3}{16}$ -inch (5 mm) and rotate the disc until the arrow on its outer ring is in line with the number 5. Lower the disc, make sure it is engaged, and release the handwheel.

**STEP 8.** Adjust the closing-stroke travel-limit disc (and the associated cams) as follows:

- (a) Manually crank the disconnect to the fully **Closed** position.
- (b) Grasp the handwheel and turn it to the extent possible in a direction opposite to the direction the output shaft rotates to close the disconnect. See Figure 56 on page 37.
- (c) With the handwheel held in the position indicated, lower the closing-stroke travel-limit disc approximately  $\frac{3}{16}$ -inch (5 mm) and rotate the disc until the arrow on the outer ring is in line with the number 5 on the indicator plate. Raise the disc, make sure it is engaged, and release the handwheel.

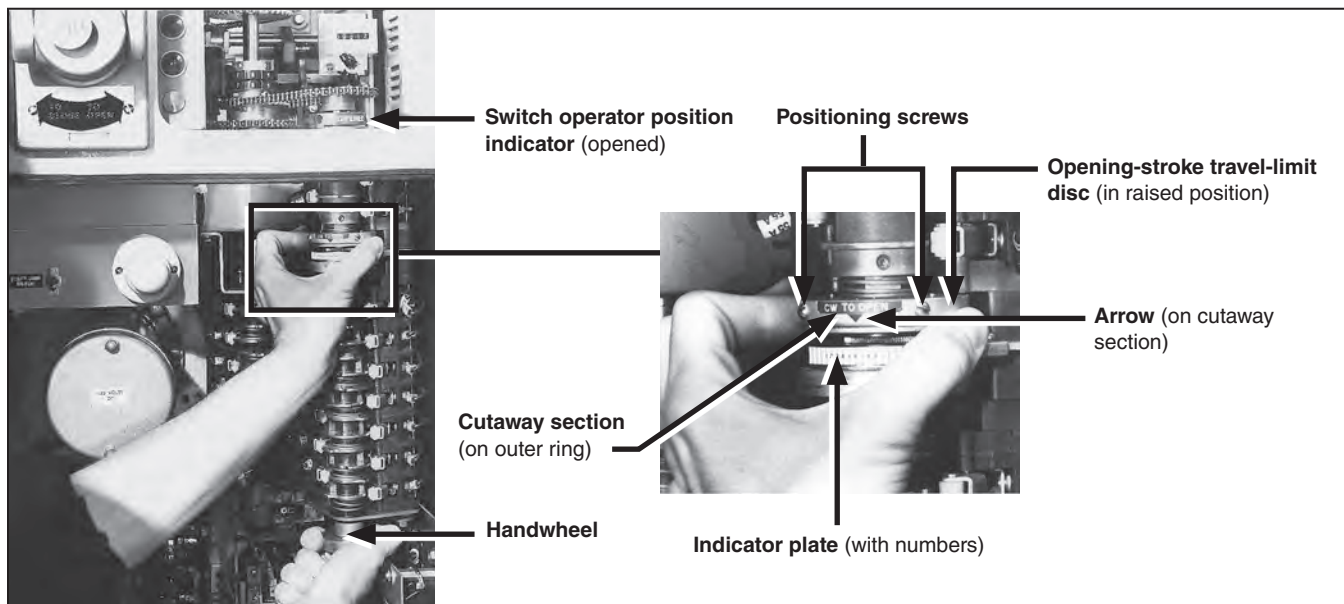

**Figure 55.** Adjustment of the opening-stroke travel-limit disc.

- STEP 9.** After adjusting the travel-limit discs, check the following:
- Place the SELECTOR handle in the **Decoupled** position.
  - Return the MANUAL OPERATING handle to its **Storage** position.
  - Reinsert the motor-circuit fuseholder.
  - Operate the switch operator electrically to open and to close the disconnect. Verify the rotation direction of the travel-limit discs for opening and closing corresponds with the direction of rotation of the output shaft and these directions agree with the direction displayed in the cutaway section on the outer ring of the travel-limit discs.

**Table 1. Adjustment of Travel-Limit Discs**

Indicator Plate Number			
Opening-Stroke Adjustment		Closing-Stroke Adjustment	
Clockwise to Open	Counterclockwise to Open	Clockwise to Close	Counterclockwise to Open
5	5	5	5

## NOTICE

When the switch operator is operated in the **Decoupled** position, the travel-limit discs do not stop at the indicator-plate positions for which they were set in Step 7 on page 36 and Step 8 on page 36. This may be disregarded.

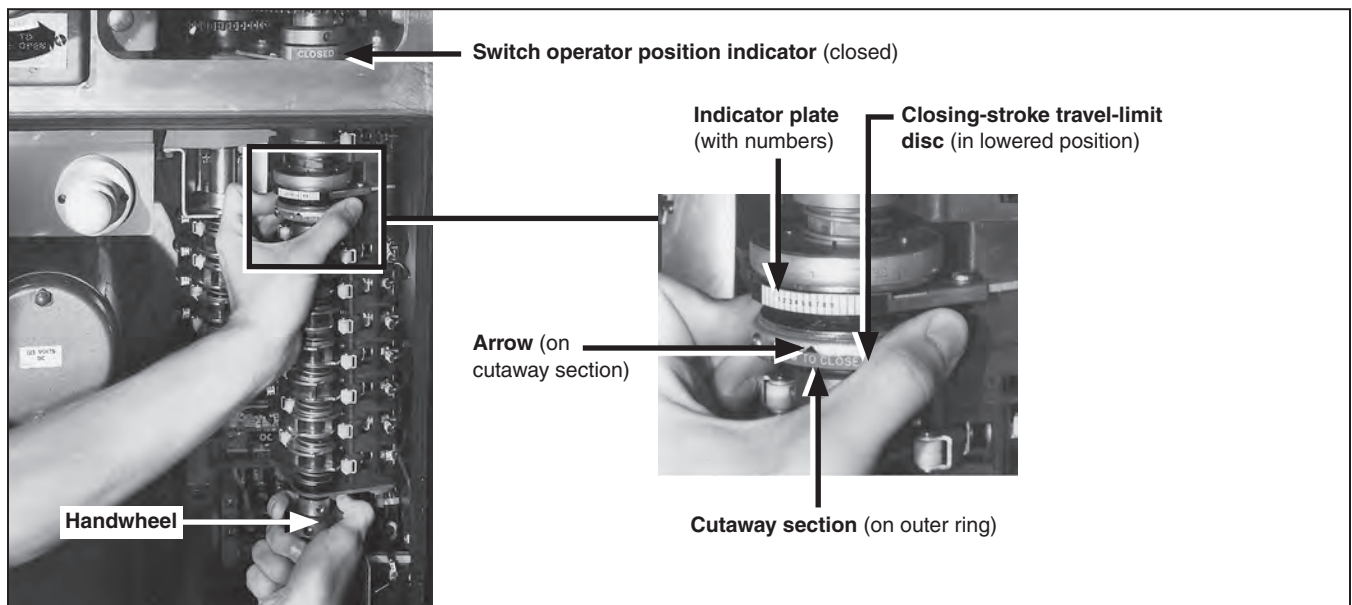

**Figure 56. Adjustment of the closing-stroke travel-limit disc.**

## Wiring and Adjusting the Switch Operator

**STEP 10.** There should always be a some “unwind” or relaxation of the output shaft (in both the **Open** and **Closed** positions) indicating the disconnect has been driven to a **Positive-toggle** position against its Open (or Closed) stop.

Check the amount of unwind in the output shaft:

- (a) Place the SELECTOR handle in the **Coupled** position. Operate the Mark VI CS-1A Switch Operator electrically to open the circuit-switcher and determine the amount of overtravel in the opening direction by releasing the motor brake and noting how far the output shaft “unwinds.”
- (b) Release the motor brake by unlatching the MANUAL OPERATING handle and pivoting it rapidly with a snap motion toward its **Cranking** position. Then, return the MANUAL OPERATING handle to its **Storage** position. There should always be a certain amount of “unwind” or relaxation of the output shaft (in both the **Open** and **Closed** positions) to indicate the circuit-switcher has been driven to a **Positive-toggle** position against its Open (or Closed) stop.

**STEP 11.** If adjustment is needed:

- (a) Remove the motor-circuit fuseholder.
- (b) Increase the amount of “unwind” by decreasing the opening-stroke travel-limit disc (to increase travel) one indicator-plate number at a time. See Figure 57.

**Note:** The direction of disc rotation is always the same as the output shaft. The output shaft should never have sufficient “unwind” when the switch operator is decoupled to cause rotation of the travel-limit discs.

- (c) If rotation of the travel-limit disc is evident, advance the opening-stroke travel-limit disc (to decrease travel) an amount necessary only to eliminate the “unwind” rotation of the travel-limit discs.

Use when the direction of the output shaft and travel-limit disc rotation is clockwise to open.

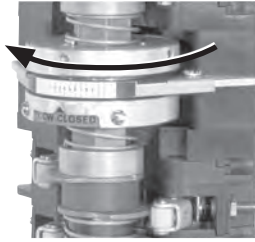

**Opening-stroke travel-limit disc** (with circuit-switcher and switch operator in the fully **Open** position—raise and turn counterclockwise to increase travel of the switch operator)

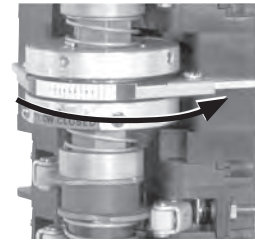

**Closing-stroke travel-limit disc** (with circuit-switcher and switch operator in the fully **Closed** position—lower and turn clockwise to increase travel of the switch operator)

Use when the direction of the output shaft and travel-limit disc rotation is counterclockwise to open.

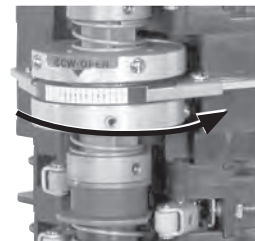

**Opening-stroke travel-limit disc** (with circuit-switcher and switch operator in the fully **Open** position—raise and turn clockwise to increase travel of the switch operator)

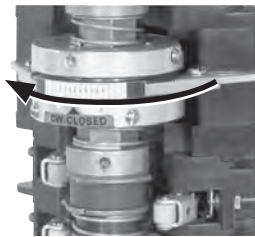

**Closing-stroke travel-limit disc** (with circuit-switcher and switch operator in the fully **Closed** position—lower and turn counterclockwise to increase travel of the switch operator)

**Figure 57.** Adjustment of travel-limit discs for desired “unwind” of output shaft.

### NOTICE

Before checking the “unwind” after a closing stroke, remove the motor-circuit fuseholder before releasing the motor brake. Excessive “unwind” at this point could cause rotation of the travel-limit switch sufficient to pick up a “bb” contact, which, in turn, would cause the switch operator to open (if energized).

- (d) With the MANUAL OPERATING handle in its **Storage** position, reinsert the motor-circuit fuseholder, and operate the switch operator electrically to close the circuit-switcher disconnect.
- (e) Repeat this procedure and adjust the closing-stroke travel-limit disc one indicator-plate number at a time to obtain the correct amount of overtravel in the closing direction.

**STEP 12.** Check the operation of the disconnect by operating the switch operator several times to observe the action. Operation should appear smooth, with the disconnect drive-shaft cranks coming to rest firmly against their stops, in an **Overtoggle** position, in both opening and closing directions.

If necessary, realign the disconnect position indicators on the switch operator output-shaft collar with the alignment arrow. See Figure 58.

With the switch operator in the fully **Open** position and then in the fully **Closed** position, check the corresponding switch operator position indicator. In each position, the corresponding position indicator should be readily visible from the front of the enclosure.

***If adjustment of either position indicator is necessary:*** Remove the motor-circuit fuseholder, loosen the two set screws (see Figure 58) and rotate the indicator to the desired position. Retighten set screws.

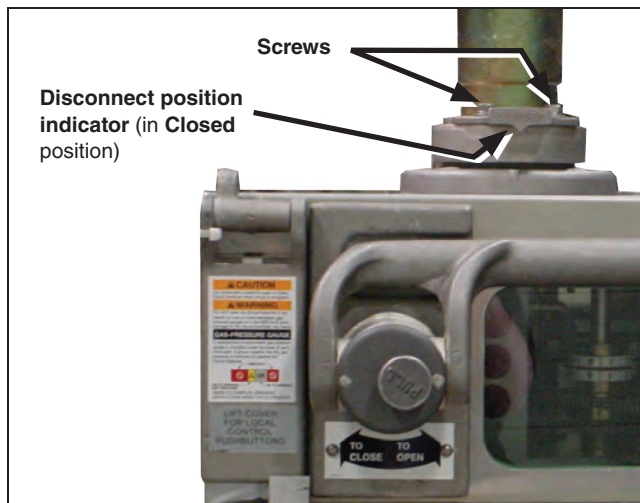

**Figure 58.** Align the position indicator arrow.

## Wiring and Adjusting the Switch Operator

**STEP 13.** The auxiliary switch, which is permanently coupled to the motor, includes eight contacts, Terminals 11 through 26. (If the optional position-indicating lamps are included, six contacts are available: Terminals 13 through 18, and Terminals 21 through 26.) These contacts permit external circuits to be established to monitor switching operations. A cam-actuated roller operates each contact. The cams are individually adjustable in 4.5-degree increments and can be positioned so roller engagement occurs at the desired point in the operating cycle.

The “standard” configuration for the auxiliary switch consists of four “a1” contacts, Terminals 11 through 18, and four “b1” contacts, Terminals 19 through 26. Thus, with the switch operator in the **Open** position, the “a1” contacts are open and the “b1” contacts are closed. With the switch operator in the **Closed** position, the “a1” contacts are closed and the “b1” contacts are open. A contact is closed if its roller is disengaged from a cam and is open if its roller is engaged by a cam. See Figure 59 and Figure 60.

Any auxiliary-switch contact must be checked for proper operation after the switch operator travel-limit discs have been adjusted. Check the auxiliary-switch contacts for both **Open** and **Closed** positions of the switch operator.

To adjust the auxiliary-switch contacts, refer to Figure 60 and Figure 61 on page 41 and proceed as follows:

- (a) With the SELECTOR handle in the **Coupled** position, operate the switch operator to the fully **Closed** position.
- (b) Remove the motor-circuit fuseholder.
- (c) Determine which “a1” contacts are not in the **Closed** position. A contact is closed if its roller is disengaged from a cam and is open if its roller is engaged by a cam.
- (d) For the “a1” contacts not in the **Closed** position, raise (or lower) the corresponding cam toward its adjacent spring until the cam is separated from the teeth of the inner gear. Rotate the cam so when lowered (or raised) it is disengaged from

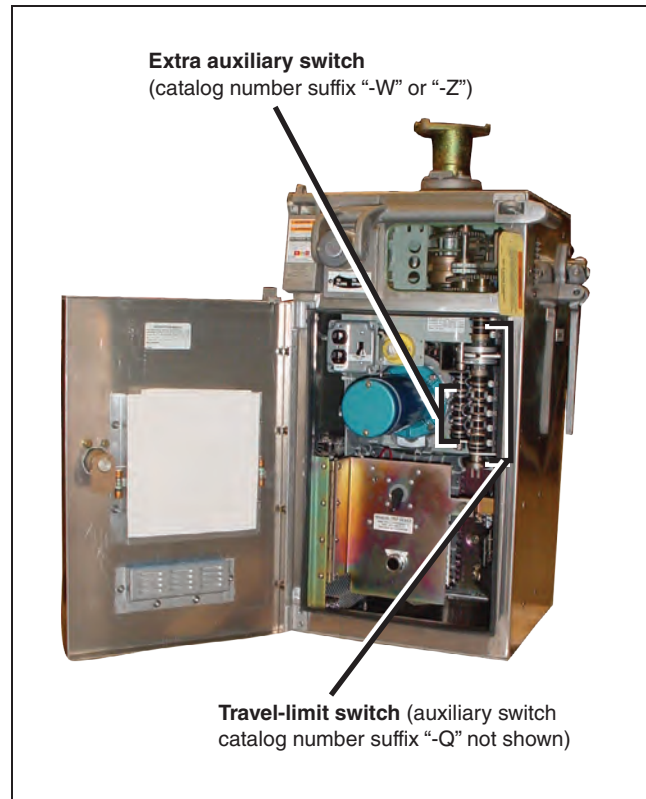

**Figure 59.** Open front view of the switch operator “standard” contact configurations.

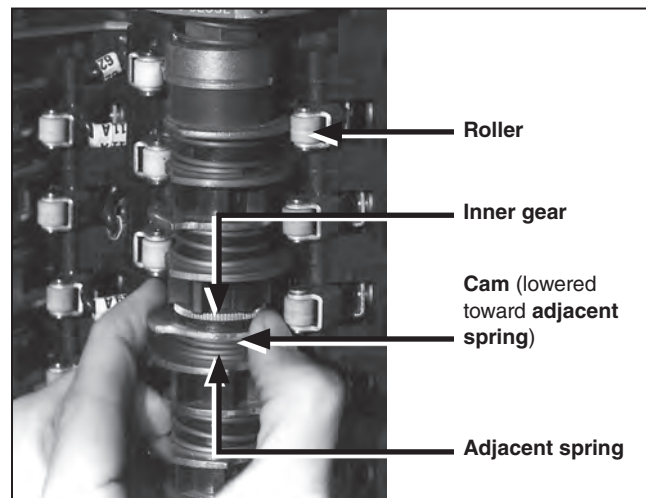

**Figure 60.** Adjustment of cams on the auxiliary switch.

the roller. Lower (or raise) the cam, making sure the teeth mesh with the inner gear and the cam is disengaged from the roller.

- (e) Reinsert the motor-circuit fuseholder.
- (f) Operate the switch operator to the fully **Open** position. Remove the motor-circuit fuseholder and, if necessary, adjust the cams as described in (d) until all “b1” contacts are in the **Closed** position.
- (g) Reinsert the motor-circuit fuseholder and operate the disconnect. Both sets of contacts should now be correctly positioned for both the **Open** and **Closed** position of the disconnect. Sufficient

adjustment is available to provide correct positioning of both sets of contacts.

Because each cam can be individually adjusted in 4.5-degree increments, any “a1” contact can be changed to a “b1” contact, or vice-versa. Because of the many positions to which the cams can be adjusted, various rollers can be engaged or disengaged to open or close their contacts either simultaneously, sequentially, randomly, or in various combinations. Adjustment of the auxiliary switch for other than the “standard” contact configuration is left to the user. The motor-circuit fuseholder should be removed when adjusting these contacts. (Switch operators furnished

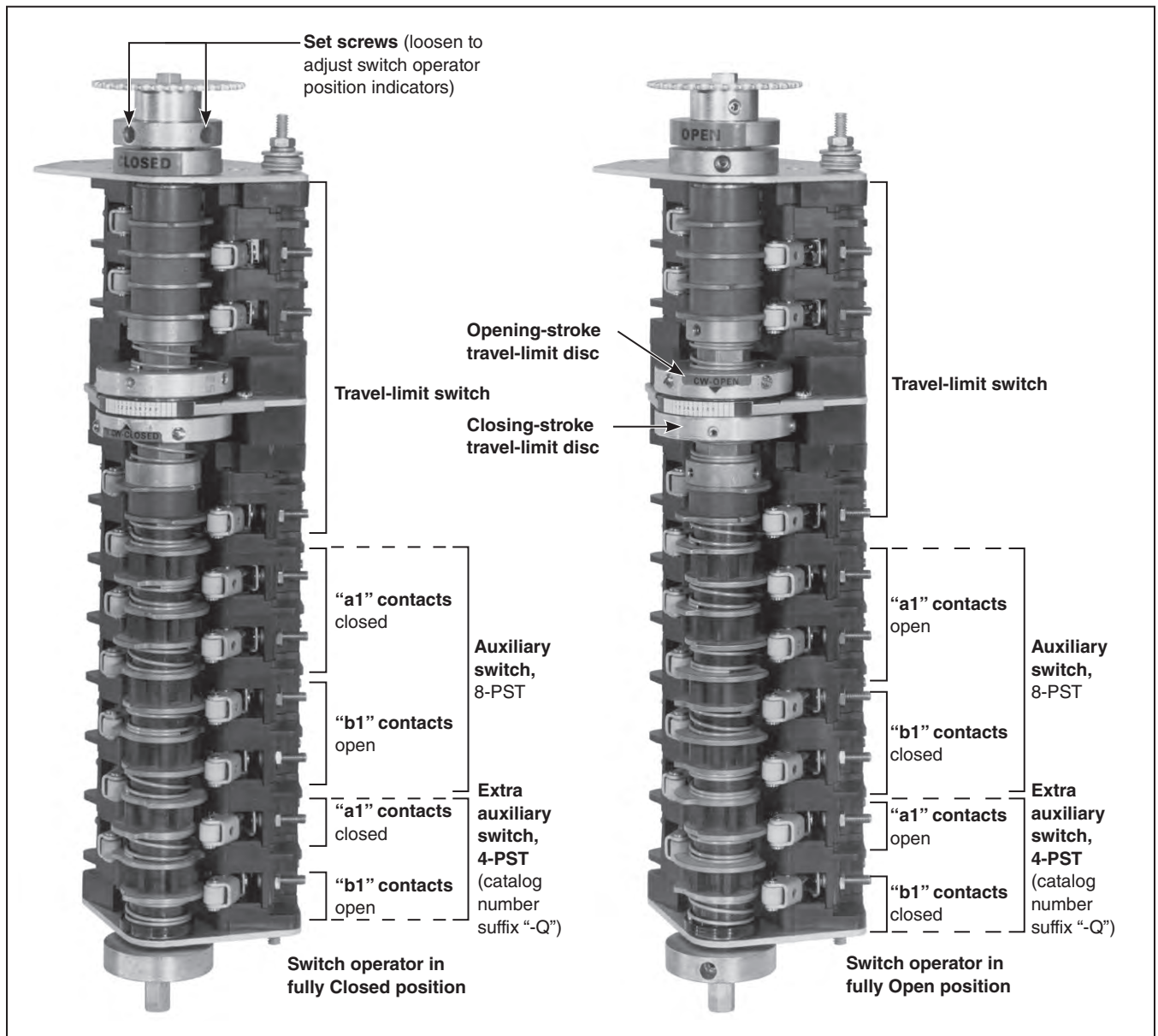

Figure 61. Travel-limit switches.

## Wiring and Adjusting the Switch Operator

with the catalog number suffix “-Q” option are equipped with an extra auxiliary switch, Terminals 27 through 34, having four contacts—two “a1” and two “b1”—that may be adjusted as described in (a) through (g).)

**STEP 14.** Switch operators furnished with either catalog number suffix “-W” or “-Z” are equipped with an extra auxiliary switch that is coupled to the disconnect. Catalog number suffix “-W” auxiliary switch consists of eight contacts, Terminals 35 through 50. Catalog number suffix “-Z” auxiliary switch consists of twelve contacts, Terminals 35 through 50 plus Terminals 80 through 87. These contacts permit external circuits to be established to monitor disconnect operation. A cam-actuated roller operates each contact and the cams are individually adjustable in 4.5-degree increments.

The “standard” configuration for catalog number suffix “-W” extra auxiliary switch consists of four “a2” contacts, Terminals 35 through 42, and four “b2” contacts, Terminals 43 through 50. The “standard” configuration for catalog number suffix “-Z” extra auxiliary switch consists of six “a2” contacts, Terminals 35 through 42 and Terminals 80 through 83, and six “b2” contacts, Terminals 43 through 50 and Terminals 84 through 87.

With the disconnect in the fully **Closed** position, the “a2” contacts should be closed and the “b2” contacts should be open. With the disconnect in the fully **Open** position, the “a2” contacts should be open and the “b2” contacts should be closed. See Figure 62.

Any catalog number suffix “-W” or “-Z” auxiliary switch contact being used must be checked for proper operation after satisfactory electrical operation of the disconnect has been achieved. Check the auxiliary-switch contact engagement for both the **Open** and **Closed** positions of the disconnect. Adjustment of catalog number suffix “-W” or “-Z” extra auxiliary switch is identical to the procedure for the standard auxiliary switch and catalog number suffix “-Q” extra auxiliary switch. If adjustment of catalog number suffix “-W” or “-Z” auxiliary switch is needed, refer to Step 13 and Figure 60 on page 40 and Figure 62.

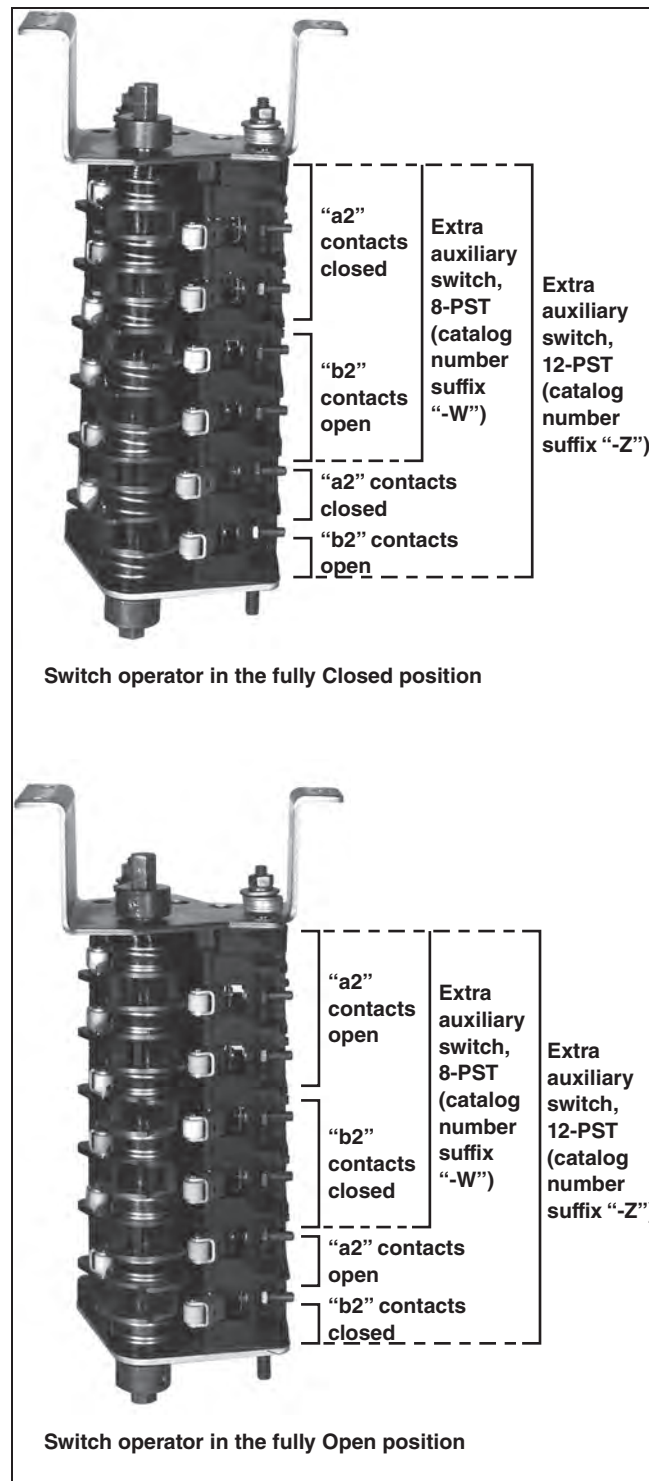
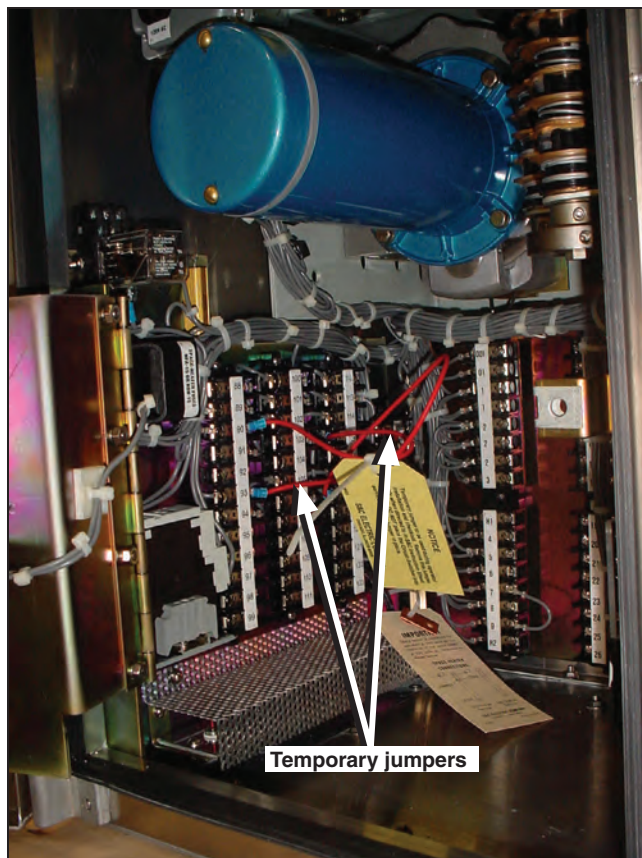

Figure 62. Auxiliary switches.

**STEP 15.** Make sure all protective-relay, control-circuit and control-power wiring is complete. Wire the interrupters and charging motors to the Mark VI CS-1A Switch Operator using the following procedure:

- (a) Disconnect power to the Mark VI CS-1A Switch Operator by removing the fuse-holder inside the operator enclosure.
- (b) With control power disconnected, remove the temporary jumpers between the interrupter contacts. Discard the jumpers. See Figure 63.
- (c) Following the wiring diagram furnished, make up the electrical connections from the charging motors and interrupters to the appropriate terminal blocks inside the Mark VI CS-1A Switch Operator. **DO NOT** apply control power at this time.

Control power will be applied during “Startup” on page 46.



**Figure 63.** Remove the temporary jumpers and wire the interrupters to the appropriate terminals in the Mark VI CS-1A Switch Operator per the wiring diagram.

# Terminal Pad and Conductor Connections

## Installing the Terminal Pad

Repeat Step 1 through Step 2 for each pole-unit.

### NOTICE

**DO NOT** exceed the terminal pad loading limits outlined in S&C Information Bulletin 712-60. **Failure to do so can result in damage to the Mark VI Circuit-Switcher.**

**STEP 1.** Remove the lifting bracket from the interrupter. Make sure all packing material has been removed from the top of the interrupter. See Figure 64.

### NOTICE

The lifting brackets must be removed before energizing the Mark VI Circuit-Switcher. **Failure to do so can result in damage to the interrupters.**

**STEP 2.** Prepare the interrupter terminal pad attachment as follows:

- Thoroughly clean the terminal pad using a soft cloth.
- Thoroughly wire-brush the appropriate set of holes on the interrupter casting.
- Immediately apply a liberal coating of Penetrox A or other suitable aluminum connector compound to the clean surfaces.
- Apply Penetrox A to the threads of two  $\frac{1}{2}$ -13  $\times$  1-inch hex-head stainless steel cap screws furnished.
- Attach the terminal pad to the appropriate set of tapped holes on the interrupter. Tighten the screws to a torque of 40 to 50 ft.-lbs. See Figure 65.

### NOTICE

Do not use a wire-brush to clean the upper terminal pad. Abrasive cleaning may damage the terminal pad plating and cause corrosion.

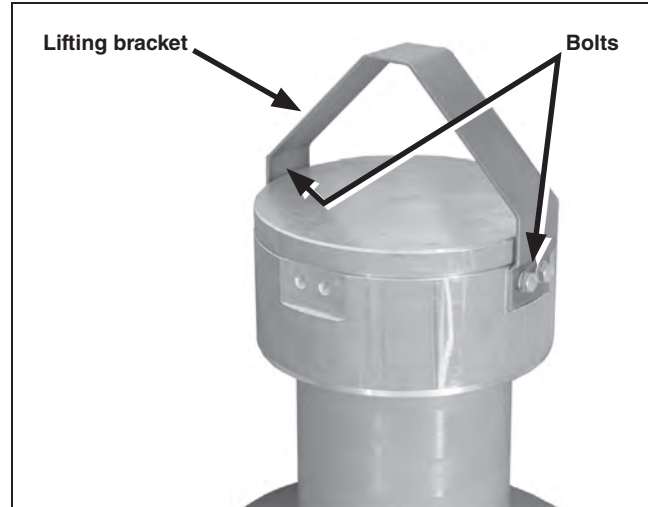

Figure 64. Remove the lifting bracket.

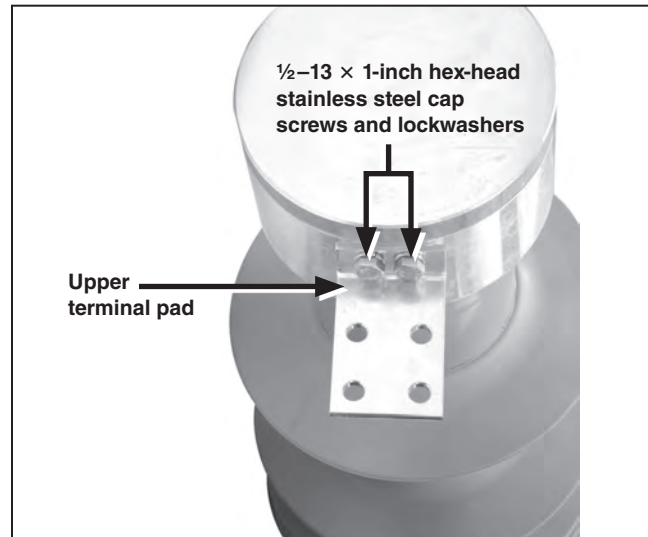

Figure 65. Bolt the upper terminal pad to the interrupter.

- STEP 3.** Prepare the jaw-end terminal pad as follows:
- Thoroughly wire-brush the terminal pad casting.
  - Immediately apply a liberal coating of Penetrox A or other suitable aluminum connector compound to the clean surface. See Figure 66.

### Connecting Conductors

**⚠ DANGER**

Conductors must be de-energized and grounded in accordance with standard system operating practice. **Failure to do so will result in serious injury or death.**

- STEP 1.** Attach the conductors to their respective terminal pads using flexible-conductor connections. Attach and form the conductors to minimize terminal-pad loadings. Do not exceed the terminal-pad loadings specified in Information Bulletin 712-60.
- STEP 2.** After attaching conductors, recheck the alignment of the disconnect as described in Step 2 on page 15.

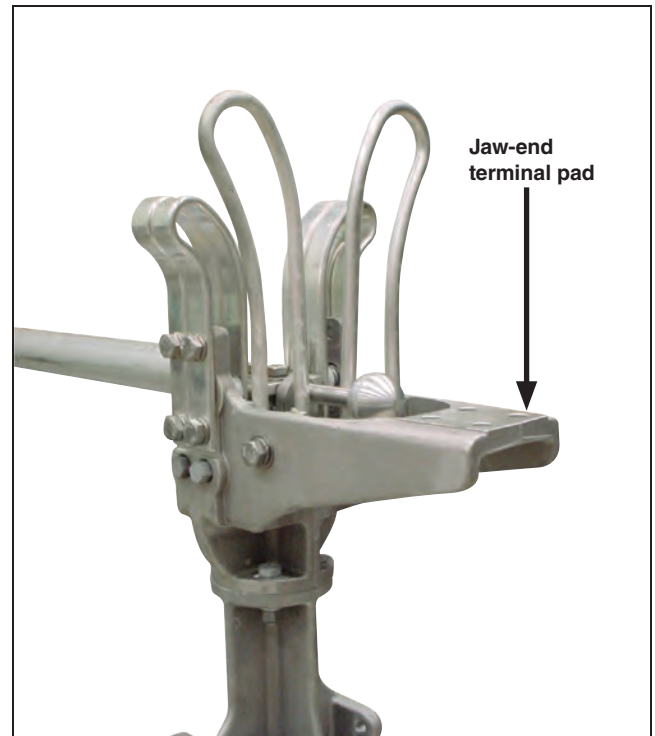

**Figure 66.** Prepare the jaw-end terminal pad.

## Circuit-Switcher Startup and Checkout

### Startup

#### **⚠ DANGER**

Conductors must be de-energized and grounded in accordance with standard system operating practice. **Failure to do so will result in serious injury or death.**

- STEP 1.** Verify the disconnect is in the **Coupled** position by looking at the internal decoupling mechanism inside the Mark VI CS-1A Switch Operator. See Figure 67 and Figure 68. If the switch operator is in the **Decoupled** position, manually operate the switch operator to bring it **Open** or **Closed**). See Figure 68. For instructions on coupling the switch operator, refer to “Using the Selector Handle (Coupling and Decoupling)” on page 31.
- STEP 2.** Crank the MANUAL OPERATING handle on the Mark VI CS-1A Switch Operator until the disconnect is in the fully **Open** position. Visually inspect the blade to confirm it is open. See Figure 69 on page 47. For instructions on using the MANUAL OPERATING handle refer to “Using the Manual Operating Handle” on page 30.
- STEP 3.** Verify the interrupters are in the **Open** position and each gas-pressure gauge on the underside of the interrupter is in the OK to Operate zone. See Figure 70 on page 47.

#### **NOTICE**

The gas-pressure gauge needle should be in the OK to Operate zone. If the gauge is not in this position, stop the installation and notify S&C Electric Company.

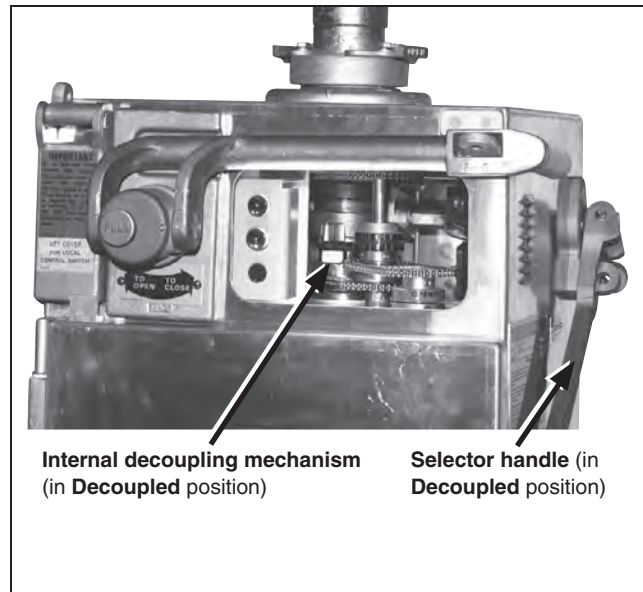

Figure 67. View of decoupled switch operator through observation window.

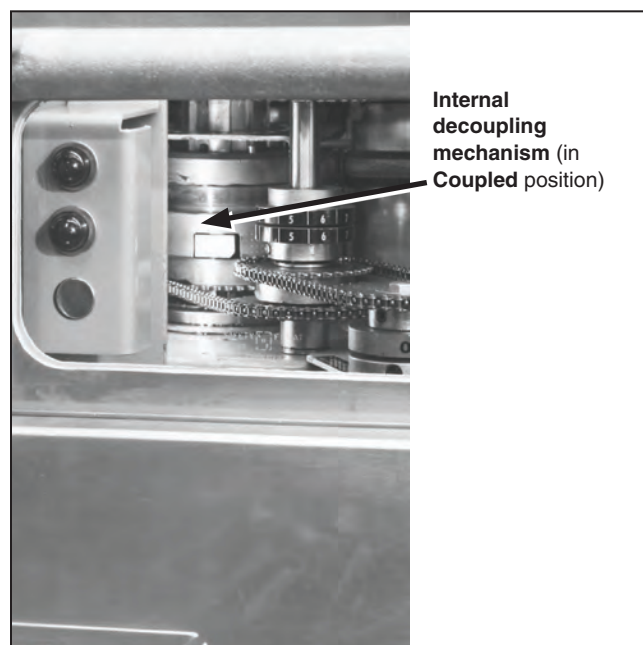

Figure 68. View of coupled switch operator through observation window.

**STEP 4.** Reconnect control power to the operator by replacing the fuseholder in the Mark VI CS-1A Switch Operator. The charging motors should begin closing and charging the interrupter.

## NOTICE

The interrupter charging motors have a **Return-to-Home** feature. If control power is disconnected during an interrupter charging operation, when power is restored, the circuit will prompt the motors to return to **Home** position:

**If control power is disconnected prior to the interrupters being latched and closed**, the motor will return to the start of the charging cycle (**Home** position) and the interrupter indicators will show **Open** before the charging cycle automatically begins again.

**If control power was disconnected after the interrupters were latched and closed**, the motor will back out to the **Home** position and the interrupter indicators will show **Closed**.

## DANGER

Conductors must be de-energized and grounded in accordance with standard system operating practice. **Failure to do so will result in serious injury or death.**

**STEP 5.** If the interrupter charging motors do not immediately begin charging, remove the fuseholder, recheck the wiring connections per the furnished wiring diagram, and reapply power to the operator. If the motors still do not start, stop the installation and notify S&C Electric Company.

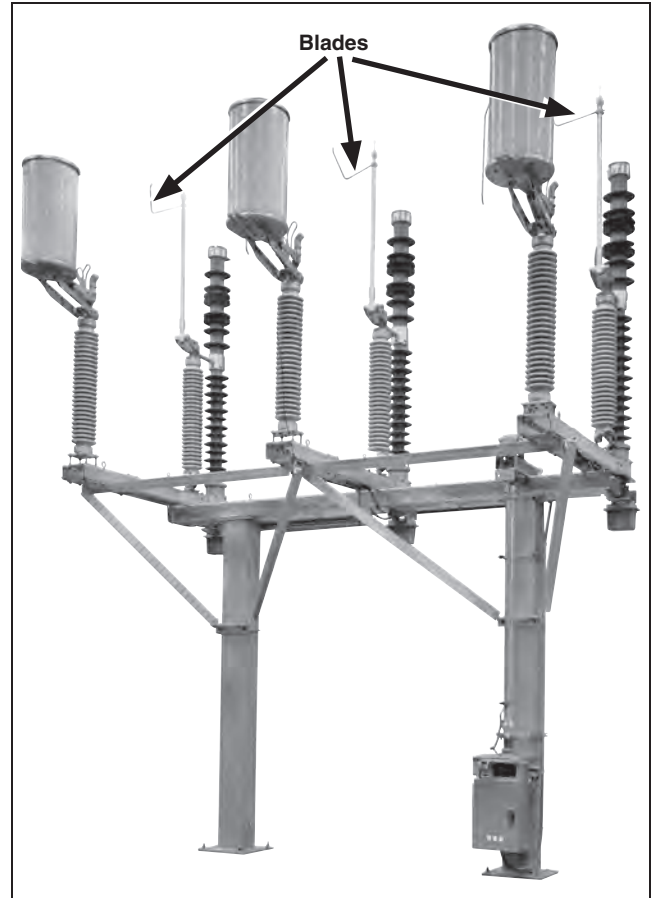

Figure 69. Switch with disconnect in Open position.

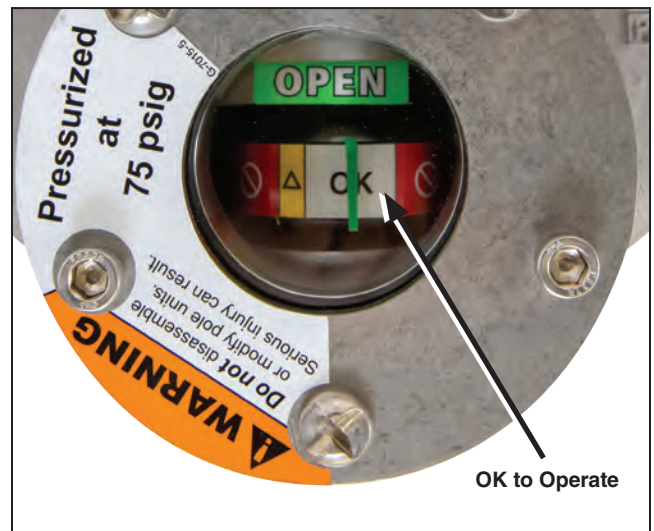

Figure 70. Make sure the indicator reads “OPEN.” Make sure the gas-pressure gauge on each interrupter is in the OK to Operate zone.

## Checkout

The following instructions assume the switch operator output shaft has been connected to the disconnect drive train, the electrical connections to the control source have been completed, and the switch operator has been correctly adjusted.

Using this instruction sheet, the furnished reference drawing, and S&C Instruction Sheet 712-501 as a guide, visually inspect the entire installation. Verify the following:

### Mounting Structure

- Make sure fasteners for the pole-unit bases are securely tightened.
- Make sure all packaging materials, lifting brackets, and eyebolts have been removed.

### Pole-Units

- Make sure fasteners for the interrupter mounting brackets, support brackets, and motor brackets are securely tightened.
- Make sure all packaging materials, lifting brackets, and eyebolts have been removed.
- Make sure conduit is securely fastened.
- Check for damage to the porcelain insulators and interrupters. Clean dirt and grease from the insulation.

- Make sure the manual hand crank is not attached to a disconnect. If it is, remove it.
- Check for torque in the bus connection between the interrupters and disconnect. Loosen and reposition interrupter base if necessary.

### Drive Train

- Make sure all drive train couplings are secure, and none of the piercing set screws are loose or protruding through the coupling clamp.
- Make sure the grounding strap attached to the base of the vertical operating shaft is properly grounded.
- Make sure the gearbox is level and all fasteners are secure.

### Mark VI CS-1A Switch Operator

- Make sure all electrical connections are landed on the appropriate terminal blocks, per the furnished wiring diagram.
- Make sure all terminal block screws are secure.
- Make sure the temporary jumpers have been removed and discarded.
- Make sure all control-power and wiring conduit entrances are sealed with a watertight sealant.

The switch can now be operated according to the instructions in S&C Instruction Sheet 712-501.

### Understanding the Interrupter Indicators

The interrupter indicators are located underneath the interrupter base. The indicators are not meaningful while the interrupter is being closed and charged.

If the interrupter is **Open and Discharged** position, the indicator shows “OPEN.” See Figure 71.

If the interrupter is in the **Closed and Charged** position, the indicator shows “CLOSED.” See Figure 72.

### Understanding the Gas-Pressure Gauge

The temperature-compensated gas-pressure gauge is located underneath the interrupter base. It shows whether SF<sub>6</sub> gas density is sufficient for a **Trip** operation. The gas-pressure gauge shows three zones:

#### OK to Operate

This is the white zone. If the gauge needle is in this zone, the interrupter is at normal gas density, and can be opened and closed. See Figure 73.

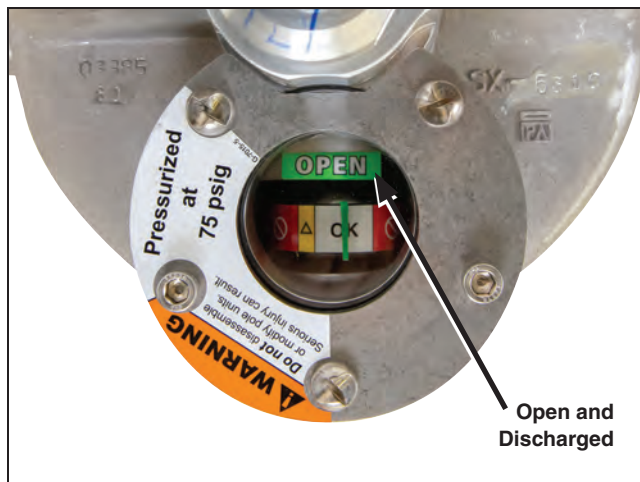

Figure 71. The interrupter is Open and Discharged. The indicator shows “OPEN.”



Figure 72. The interrupter is Closed and Charged. The indicator shows “CLOSED.”

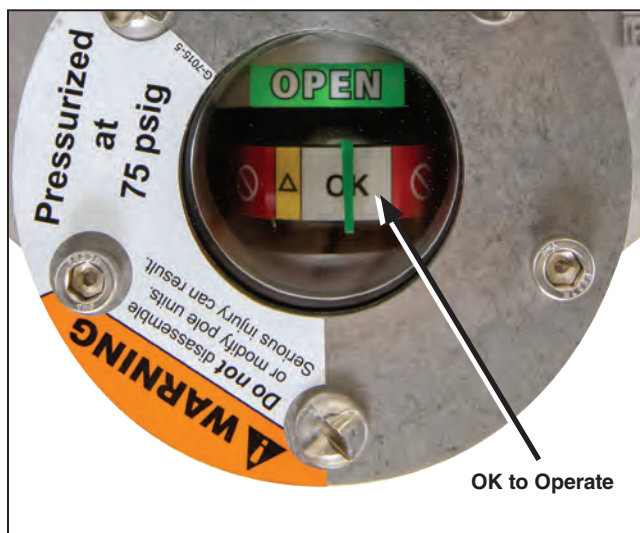

Figure 73. Gauge needle in white OK to Operate zone.

### **OK to Operate (but replace)**

This is the yellow zone. If the gauge needle is in this zone, the interrupter can be opened and closed with full ratings. However, the interrupter has lost gas and should be replaced as soon as possible. See Figure 74

### **Replace**

There are two red zones. If the indicator needle is in the red zone shown in Figure 75, the gas density in the interrupter has dropped below the minimum functional level and the interrupter will not maintain full interrupting or dielectric ratings. The interrupter should be removed from service and replaced promptly. Do not operate the Mark VI Circuit-Switcher.

If the indicator needle is in the red zone shown in Figure 76 on page 51, the local gas-density gauge is damaged and cannot be relied on to provide an accurate indication of gas density. The interrupter should be removed from service and replaced promptly. Contact your local S&C Sales Office. Do not operate the Mark VI Circuit-Switcher.

### **NOTICE**

At temperatures below  $-31^{\circ}\text{F}$  ( $-35^{\circ}\text{C}$ ), the indicator needle will be in the red zone due to the cold temperature. The normal operating temperature for the Mark VI Circuit-Switcher is  $+40^{\circ}\text{C}$  to  $-35^{\circ}\text{C}$ ; below this temperature the gas density does not allow the full interrupting or dielectric capability of the switch. At these temperatures, the gas-pressure gauge does not accurately indicate whether an interrupter is losing  $\text{SF}_6$  gas.

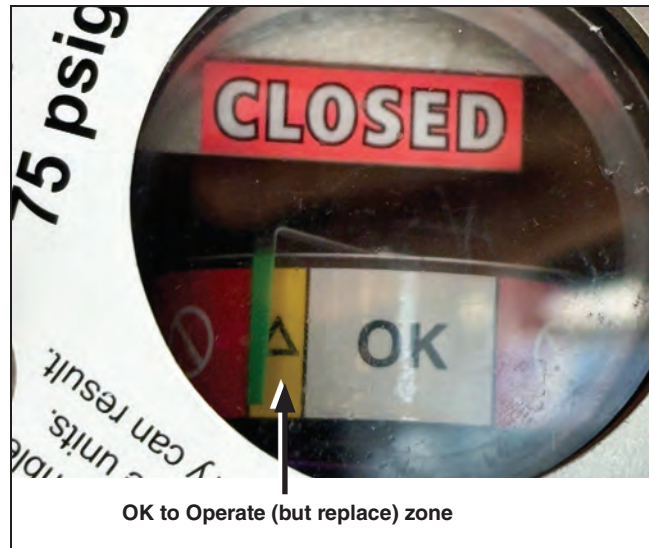

Figure 74. Gauge needle in yellow OK to Operate (but replace) zone.



Figure 75. Gauge needle in red Replace zone.

### Understanding the Optional Remote Gas-Density Indicator

If furnished, the remote gas-density indicator provides contacts for each interrupter allowing remote monitoring of two low-gas-pressure alarms:

#### Level 1 Alarm:

When a Level 1 Alarm is issued, the interrupter can be opened and closed as usual. However, the interrupter has lost gas and should be replaced as soon as possible.

The remote gas-density Level 1 alarm contact opens at 93% of normal density, or 70 PSIG at 68°F (20°C). Contacts are normally closed at normal operating gas pressure.

#### Level 2 Alarm:

When a Level 2 Alarm is issued, the gas density in the interrupter has dropped below the minimum functional level. The interrupter will not maintain full interrupting or dielectric ratings. The interrupter should be removed from service and replaced promptly. **DO NOT** operate this Mark VI Circuit-Switcher.

The remote gas-density Level 2 alarm contact opens at 88% of normal density, or 65 PSIG at 68° (20°C). Contacts are normally closed at normal operating gas pressure.

#### NOTICE

At temperatures below – 31°F (-35°C), a **Level 2 Alarm** may be issued due to the cold temperature. At such low temperatures, gas density is below the interrupter's minimum functional level, so the interrupter will not have full interrupting or dielectric ratings. **At these temperatures, a Level 2 Alarm does not accurately indicate whether an interrupter is losing SF<sub>6</sub> gas.**



Figure 76. The other red Replace zone.