

Brain Adjustment

Table of Contents

Introduction	2	Overtravel Measurement and Adjustment	6
Qualified Persons	2	Measuring Overtravel	6
Read This Instruction Sheet	2	Overtravel Adjustment on Vertical-Break and	
Retain This Instruction Sheet	2	Integer-Style Circuit-Switchers	10
Proper Application.....	2	Overtravel Adjustment on Center-Break Style	
Safety Information	3	Circuit-Switchers	12
Understanding Safety-Alert Messages	3	Latch-Gap Measurement and Adjustment	14
Following Safety Instructions.....	3	Measuring the Latch Gap for Mark V	
Replacement Instructions and Labels	3	Circuit-Switchers	14
Safety Precautions	4	Adjusting the Latch Gap on Mark IV and Mark V	
Overview	5	Circuit-Switchers	15
Before Starting	5		

★ Instructions also applicable to similar models of Mark IV Circuit-Switchers.



Introduction

Qualified Persons

WARNING

Only qualified persons knowledgeable in the installation, operation, and maintenance of overhead and underground electric transmission and distribution equipment, along with all associated hazards, may install, operate, and maintain the equipment covered by this publication. A qualified person is someone trained and competent in:

- The skills and techniques necessary to distinguish exposed live parts from nonlive parts of electrical equipment
- The skills and techniques necessary to determine the proper approach distances corresponding to the voltages to which the qualified person will be exposed
- The proper use of special precautionary techniques, personal protective equipment, insulated and shielding materials, and insulated tools for working on or near exposed energized parts of electrical equipment

These instructions are intended only for such qualified persons. They are not intended to be a substitute for adequate training and experience in safety procedures for this type of equipment.

Read This Instruction Sheet

NOTICE

Thoroughly and carefully read this instruction sheet and all materials included in the product's instruction handbook before adjusting the Mark V Circuit-Switcher. Become familiar with the Safety Information on page 3 and Safety Precautions on page 4. The latest version of this publication is available online in PDF format at sandc.com/en/contact-us/product-literature/.

Retain This Instruction Sheet

This instruction sheet is a permanent part of the Mark V Circuit-Switcher. Designate a location where users can easily retrieve and refer to this publication.

Proper Application

WARNING

This procedure is only intended for integer-, vertical-break, and center-break style Mark IV and Mark V Circuit-Switchers rated 34.5 kV through 345 kV. It is not intended for "twin brain" 345-kV or 500-kV Mark IV Circuit-Switchers. Ratings for Mark V Circuit-Switchers are listed in the ratings table in S&C Specification Bulletin 711-31. The ratings are also on the nameplate affixed to the product.

Understanding Safety-Alert Messages

Several types of safety-alert messages may appear throughout this instruction sheet and on labels and tags attached to the product. Become familiar with these types of messages and the importance of these signal words:

⚠ DANGER
“DANGER” identifies the most serious and immediate hazards that will likely result in serious personal injury or death if instructions, including recommended precautions, are not followed.

⚠ WARNING
“WARNING” identifies hazards or unsafe practices that can result in serious personal injury or death if instructions, including recommended precautions, are not followed.

⚠ CAUTION
“CAUTION” identifies hazards or unsafe practices that can result in minor personal injury if instructions, including recommended precautions, are not followed.

NOTICE
“NOTICE” identifies important procedures or requirements that can result in product or property damage if instructions are not followed.

Following Safety Instructions

If any portion of this instruction sheet is unclear and assistance is needed, contact the nearest S&C Sales Office or S&C Authorized Distributor, or call the S&C Global Support and Monitoring Center at 1-888-762-1100. Telephone numbers are also listed on S&C’s website, sandc.com.

NOTICE	
Read this instruction sheet thoroughly and carefully before adjusting the brain of the Mark V Circuit-Switcher.	

Replacement Instructions and Labels

If additional copies of this instruction sheet are required, contact the nearest S&C Sales Office, S&C Authorized Distributor, S&C Headquarters, or S&C Electric Canada Ltd.

It is important any missing, damaged, or faded labels on the equipment be replaced immediately. Replacement labels are available by contacting the nearest S&C Sales Office, S&C Authorized Distributor, S&C Headquarters, or S&C Electric Canada Ltd.

DANGER



Mark V Circuit-Switchers operate at high voltage. Failure to observe the precautions below will result in serious personal injury or death.

Some of these precautions may differ from your company's operating procedures and rules. Where a discrepancy exists, follow your company's operating procedures and rules.

1. **QUALIFIED PERSONS.** Access to Mark V Circuit-Switchers must be restricted only to qualified persons. See the "Qualified Persons" section on page 2.
2. **SAFETY PROCEDURES.** Always follow safe operating procedures and rules.
3. **PERSONAL PROTECTIVE EQUIPMENT.** Always use suitable protective equipment, such as rubber gloves, rubber mats, hard hats, safety glasses, and flash clothing, in accordance with safe operating procedures and rules.
4. **SAFETY LABELS.** Do not remove or obscure any of the "DANGER," "WARNING," "CAUTION," or "NOTICE" labels.
5. **OPERATING MECHANISM AND BASE.** Mark V Circuit-Switchers contain fast moving parts that can severely injure fingers. Do not remove or disassemble operating mechanisms or remove access panels unless directed by S&C Electric Company.
6. **ENERGIZED COMPONENTS.** Always consider all parts live until de-energized, tested, and grounded. Voltage levels can be as high as the peak line-to-ground voltage last applied to the circuit-switcher.
7. **GROUNDING.** The Mark V Circuit-Switcher must be connected to a suitable earth ground at the base of the utility pole, substation ground system, or to a suitable building ground for testing, before energizing the switch and at all times when energized.
The ground wire(s) must be bonded to a system neutral, if present. If the system neutral is not present, proper precautions must be taken to ensure the local earth ground, or building ground, cannot be severed or removed.
8. **SWITCH POSITION.** Always confirm the **Open/Close** position of each switch.
 - Switches and terminal pads may be energized from either side.
 - Switches and terminal pads may be energized with the switches in any position.
9. **MAINTAINING PROPER CLEARANCE.** Always maintain proper clearance from energized components.

Before Starting

 **DANGER**

De-energize the circuit-switcher, isolate it from all high-voltage sources, and ground it at all six terminals before proceeding with brain or rotating-insulator bearing replacement or the overtravel and latch-gap measurement and adjustment.

Failure to properly de-energize and ground the circuit-switcher will result in serious personal injury or death.

These instructions are for field-adjustment of the brains on Mark V Circuit-Switchers as well as Mark IV Circuit-Switchers. They are not intended for “twin brain” 345-kV or 500-kV Mark IV Circuit-Switchers. This procedure is recommended only if a pole-unit has been disassembled to replace a brain assembly or a rotating-insulator bearing or when directed by S&C Electric Company.

In the following steps, the brain will be checked and, if necessary, adjusted to obtain adequate overtravel of the interrupting rod arm and the main rod arm. Attaining these two conditions is necessary to ensure proper seating of the rod arm latches and correctly sequenced operation of the interrupting rod and the main rod.

Proper latch-gap adjustment will also be checked and, if necessary, adjusted. Attaining a proper latch gap is essential for close interrupting simultaneity and to ensure the circuit is cleared within the interrupters before the disconnect current-carrying contacts separate.

Before proceeding with the brain-adjustment procedure, the pole-unit must be reassembled and readjusted in accordance with the field-assembly and adjustment instruction sheet originally furnished with the circuit-switcher.

Overtravel Measurement and Adjustment

Measuring Overtravel

⚠ DANGER

De-energize the circuit-switcher, isolate it from all high-voltage sources, and ground it at all six terminals before proceeding with overtravel measurement and adjustment.

Failure to properly de-energize and ground the circuit-switcher will result in serious personal injury or death.

To measure overtravel, complete the following steps:

- STEP 1.** After following the user's standard procedures for clearing and tagging equipment on which work is to be performed, open the switch by pressing the OPEN pushbutton on the switch operator. ●
- STEP 2.** With the disconnect in the fully **Open** position, remove the fuseholder for the motor circuit and (if applicable) the fuseholder for the shunt-trip circuit from the switch operator.

- STEP 3.** At the brain of the pole-unit previously disassembled, remove the four $\frac{3}{8}$ - 16 \times 1 $\frac{1}{4}$ -inch hex-head stainless steel cap screws (two of that are special shoulder bolts) from the brain cover. See Figure 1. Retain the screws.

For shunt-trip-equipped circuit-switchers only: Slide down the silicone-rubber weather-sealing boot to expose the shunt-trip operating shaft tongue-and-groove joint .

- STEP 4.** Use a small screwdriver, if necessary, to pry the brain cover loose, but be careful not to damage the internal O-ring seal. On shunt-trip equipped circuit-switchers, it is necessary to rotate the cover counterclockwise to disengage it from the shunt-trip operating shaft.

- OPEN/CLOSE pushbuttons are not included on switch operators specified with catalog number suffix "-J." In such instances, momentarily jumper terminals 1 and 8 to open the circuit-switcher. (Terminal designations may differ in special wiring diagrams. In such cases, refer to the specific wiring diagram for the correct terminal designations.)

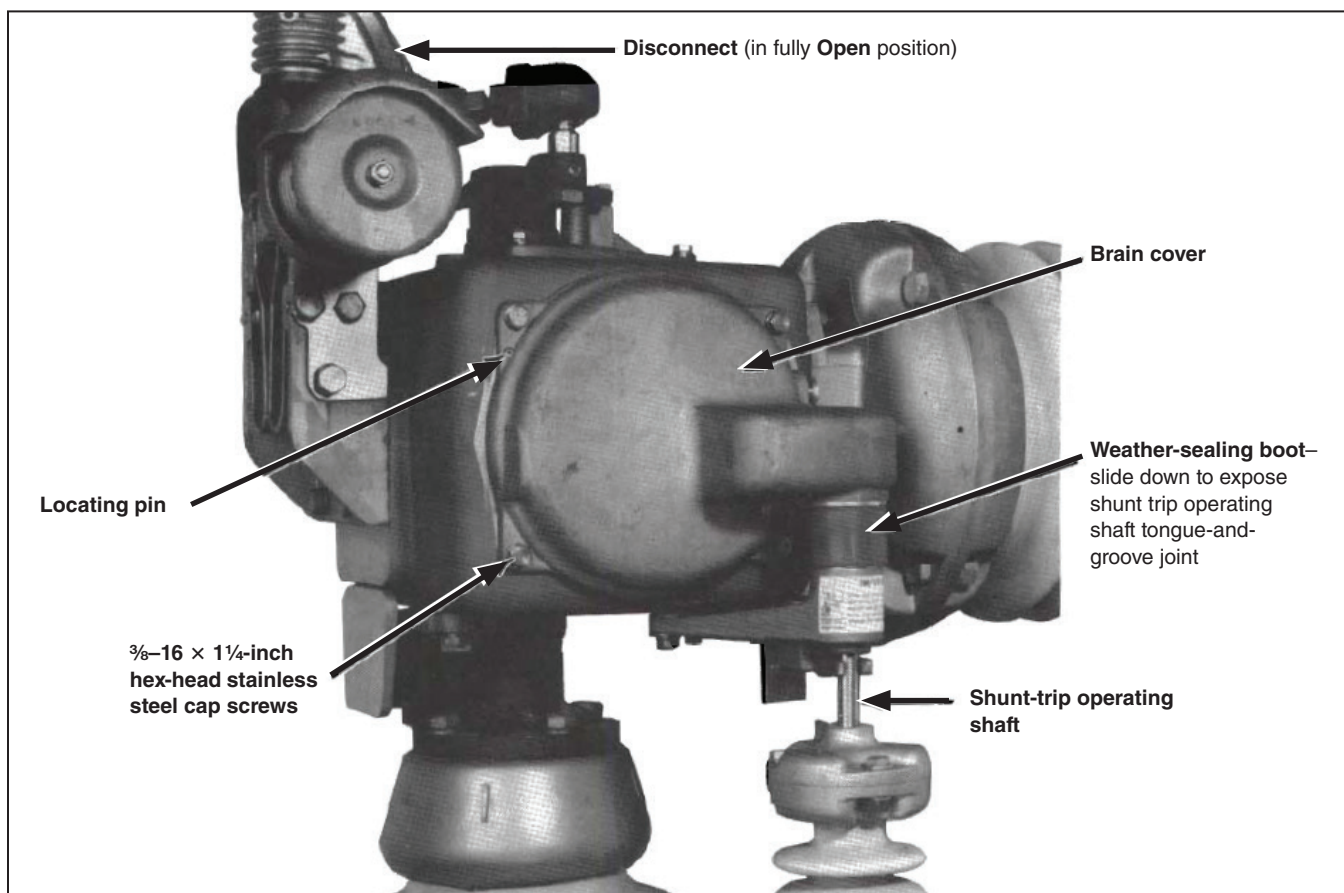

Figure 1. Removing the brain cover. Shunt-trip equipped vertical-break style circuit-switcher shown.

STEP 5. *Interrupting-rod measurement*

WARNING

To prevent serious injury to hands resulting from inadvertent tripping of the brain, do not make an interrupting rod-arm measurement unless the disconnect is at or near its fully **Open** position, as shown in Figure 1 on page 6.

After making sure the brain is in the correct position in accordance with the above warning, insert a 6-inch scale into the brain housing. Position it so its right-hand edge touches the base of the aluminum interrupting rod nut, and read the relative position of the interrupting rod arm on the scale. See Figure 2 on page 8.

It may be helpful to make a mark on the interrupting rod arm. Record this reading. Now remove the scale and take your hands out of the brain housing!

Slowly crank the manual operating handle a maximum of 1½ turns in the closing direction. Insert the scale again and read the relative position of the interrupting rod arm on the scale. Using the mark as reference, record this reading. Now remove the scale and take your hands out of the brain housing!

The difference between these readings represents the interrupting-rod-arm overtravel, and should be ½ inch (3 mm) minimum, ¾ inch (6 mm) maximum. If the difference is within the specified range, proceed to Step 6 to measure the main rod overtravel. If the difference is not within the specified range, overtravel adjustment is required. Complete the steps in Overtravel Adjustment on Vertical-Break and Integer-Style Circuit-Switchers on page 10 or Overtravel Adjustment on Center-Break Style Circuit-Switchers on page 12.

STEP 6. *Main-rod measurement*

WARNING

To prevent serious injury to hands resulting from inadvertent tripping of the brain, do not make a main rod-arm measurement unless the disconnect is at or near its fully **Open** position, as shown in Figure 1 on page 6.

Crank the manual operating handle back to the fully **Open** position. After making sure the brain is in the correct position in accordance with the above warning, insert the scale back into the brain housing, position it so its right-hand edge touches the base of the aluminum main rod nut, and read the relative position of the main rod arm on the scale. See Figure 3 on page 9. Record this reading. Now remove the scale and take your hands out of the brain housing!

Slowly crank the manual operating handle a maximum of 1½ turns in the closing direction. Insert the scale again and read the relative position of the main rod arm on the scale. Record this reading. Now remove the scale and take your hands out of the brain housing!

The difference between these readings represents the main-rod-arm overtravel, and should be ½ inch (3 mm) minimum, ¾ inch (6 mm) maximum. If the difference is within the specified range, proceed to Measuring the Latch Gap for Mark V Circuit-Switchers on page 14. If the difference is not within the specified range, overtravel adjustment is required. Complete the steps in Overtravel Adjustment on Vertical-Break and Integer-Style Circuit-Switchers on page 10 or Overtravel Adjustment on Center-Break Style Circuit-Switchers on page 12.

Overtravel Measurement and Adjustment

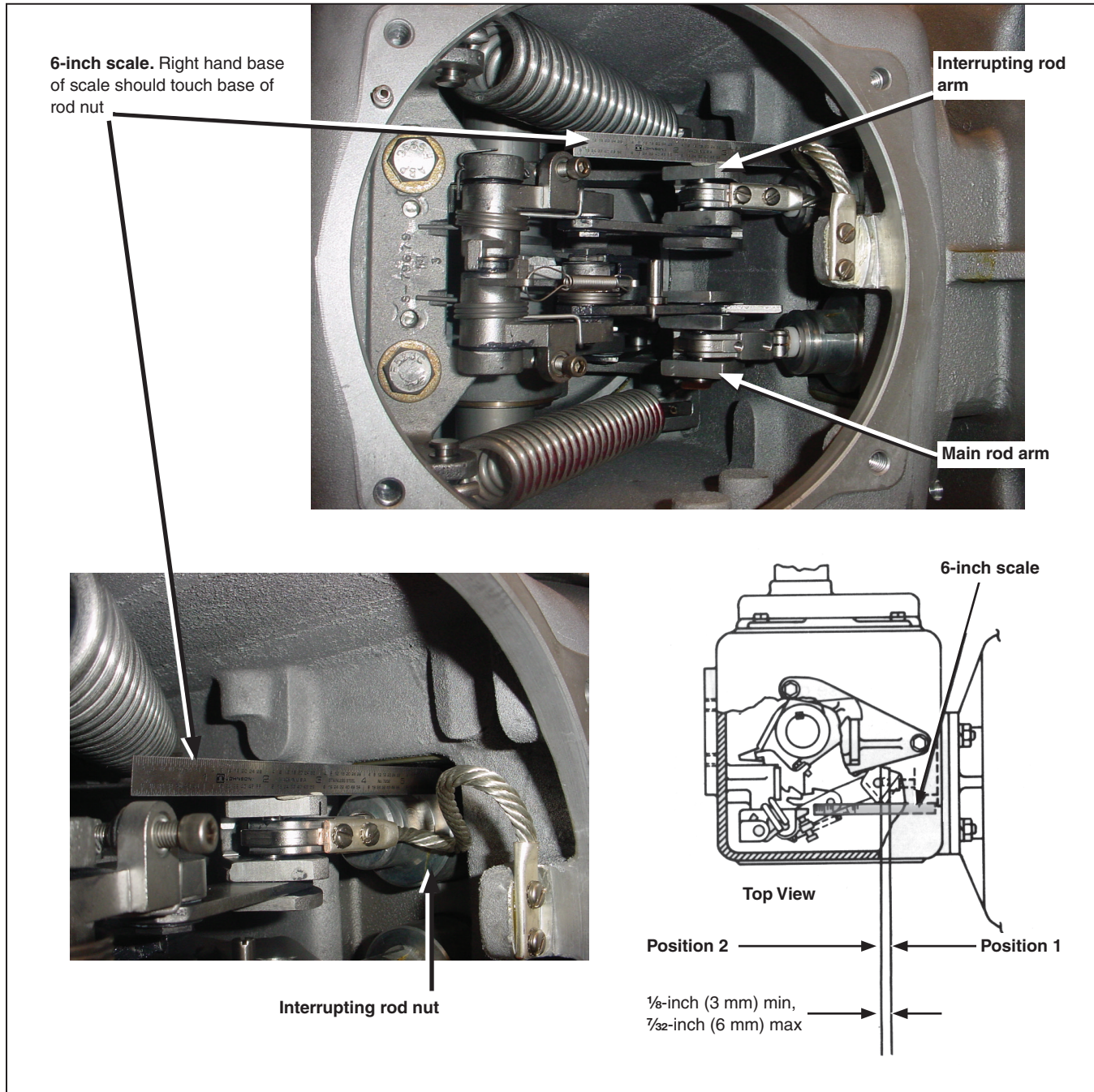

Figure 2. Interrupting-rod-arm overtravel measurement. Vertical-break style circuit-switcher shown.

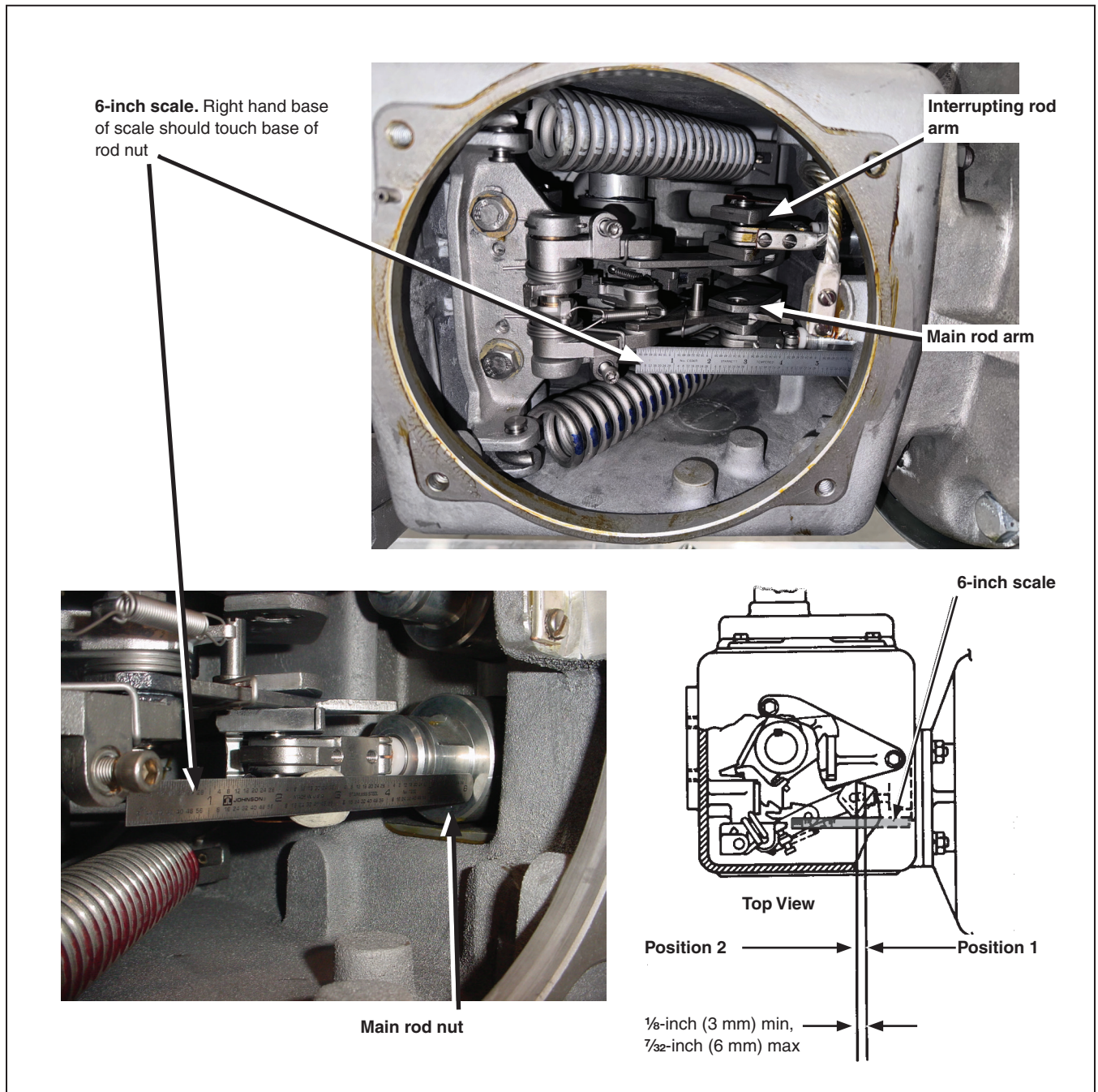

Figure 3. Main-rod-arm measurement. Vertical-break style circuit-switcher shown.

Overtravel Adjustment on Vertical-Break and Integer-Style Circuit-Switchers

⚠ DANGER

De-energize the circuit-switcher, isolate it from all high-voltage sources, and ground it at all six terminals before proceeding with overtravel measurement and adjustment.

Failure to properly de-energize and ground the circuit-switcher will result in serious personal injury or death.

If overtravel adjustment is required on a vertical-break style or integer-style circuit-switcher, perform the following:

- STEP 1.** Crank the switch fully closed. Then, slowly turn the manual operating handle just until all three interrupters are heard to trip.
- STEP 2.** Continue to slowly turn the manual operating handle a few more degrees, just to the point where the disconnect current-carrying contacts disengage their respective current-carrying jaw contacts. See Figure 4.
- With the disconnect in this position, draw a vertical positioning mark across the brain mounting flange and the rotating insulator cap. See Figure 5 on page 11.
- STEP 3.** Loosen the four $\frac{1}{2}$ – 13 × 1 $\frac{1}{4}$ -inch hex-head galvanized steel cap screws (on circuit-switchers rated 34.5 kV through 69 kV) or the four $\frac{5}{8}$ – 11 × 1 $\frac{1}{4}$ -inch hex-head galvanized steel cap screws (on circuit-switchers rated 115 kV through 161 kV) attaching the brain mounting flange to the rotating insulator cap. See Figure 5 on page 11.
- STEP 4.** **To increase overtravel:** Pull the disconnect up slightly. The brain mounting flange will rotate counterclockwise with respect to the rotating insulator cap.

To decrease overtravel: Push the disconnect down slightly. The brain mounting flange will rotate clockwise with respect to the rotating insulator cap.

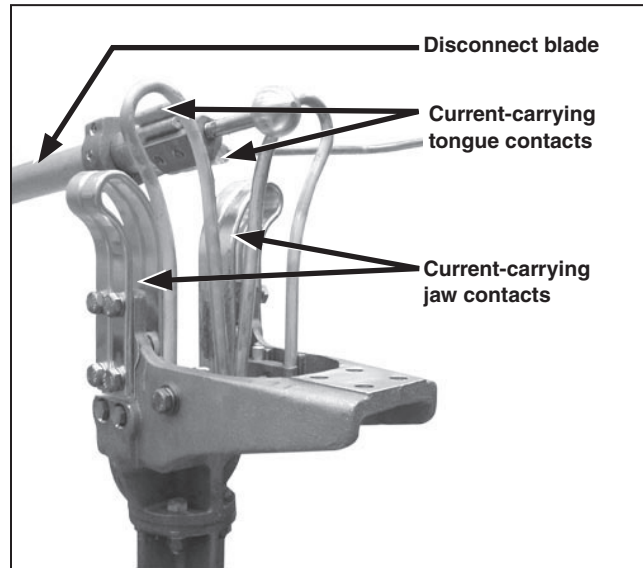

Figure 4. Disconnect position required for performing overtravel adjustment on vertical-break style or integer-style circuit-switcher. Also position required for performing latch-gap adjustment on vertical-break style or integer-style Mark IV Circuit-Switchers.

- STEP 5.** Securely tighten the cap screws attaching the brain mounting flange to the rotating-insulator cap.
- STEP 6.** Repeat the steps in Measuring Overtravel on page 6 until the difference between the interrupting-rod arm measurements and the main-rod arm measurements are within the specified ranges as stated in Step 5 on page 7 and Step 6 on page 7.

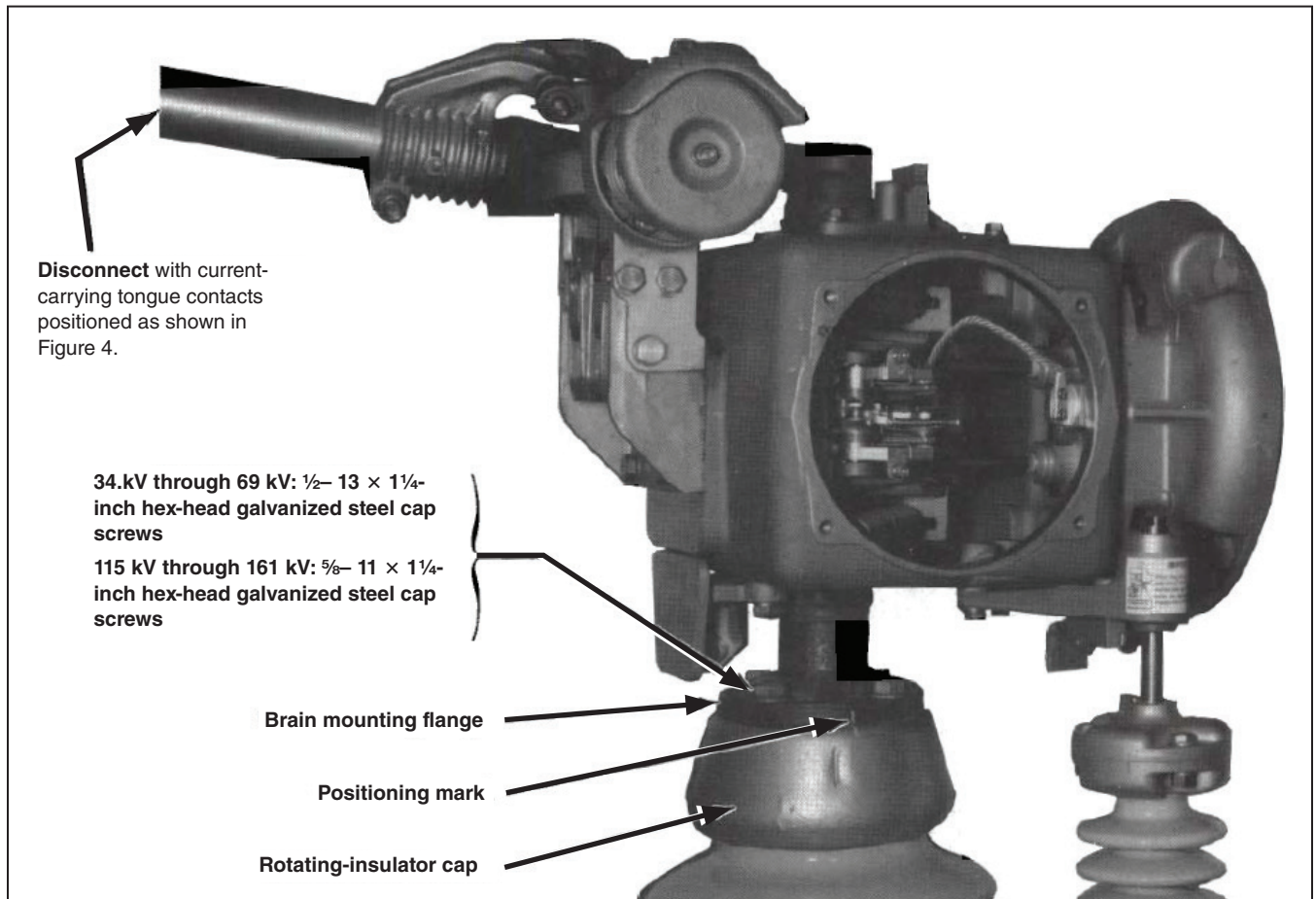

Figure 5. Overtravel adjustment on vertical-break style or integer-style circuit-switcher.

Overtravel Measurement and Adjustment

Overtravel Adjustment on Center-Break Style Circuit-Switchers

⚠ DANGER

De-energize the circuit-switcher, isolate it from all high-voltage sources, and ground it at all six terminals before proceeding with overtravel measurement and adjustment.

Failure to properly de-energize and ground the circuit-switcher will result in serious personal injury or death.

If overtravel adjustment is required on a center-break style circuit-switcher, perform the following:

- STEP 1.** Crank the switch fully closed. Then, slowly turn the manual operating handle just until all three interrupters are heard to trip.
- STEP 2.** Continue to slowly turn the manual operating handle a few more degrees, just to the point where the current-carrying tongue contacts on the terminal-end blade assemblies disengage the current-carrying jaw contacts on the interrupter-end blade assemblies. See Figure 6. With the disconnect in this position, remove the four $\frac{5}{16}$ -18 \times $1\frac{1}{4}$ -inch hex-head stainless steel cap screws and lock washers attaching the linkage cover to the top of the brain housing. See Figure 7. Retain the screws.
- STEP 3.** **To increase overtravel:** Loosen the locking nuts on the drive link and increase the effective length of the drive link by turning it one turn in the direction shown in Figure 8 on page 13.
To decrease overtravel: Loosen the locking nuts on the drive link and decrease the effective length of the drive link by turning it one turn in the direction shown in Figure 8 on page 13.
- STEP 4.** Repeat the steps in “Measuring Overtravel” on page 6 until the difference between the interrupting-rod-arm measurements and the main-arm rod measurements are within the specified ranges as stated in Step 5 on page 7 and Step 6 on page 7.

Securely tighten the locking nuts on the drive link, replace the linkage cover to the top of the brain housing, and securely tighten the four $\frac{5}{16}$ -18 \times $\frac{3}{4}$ -inch hex head stainless steel cap screws.

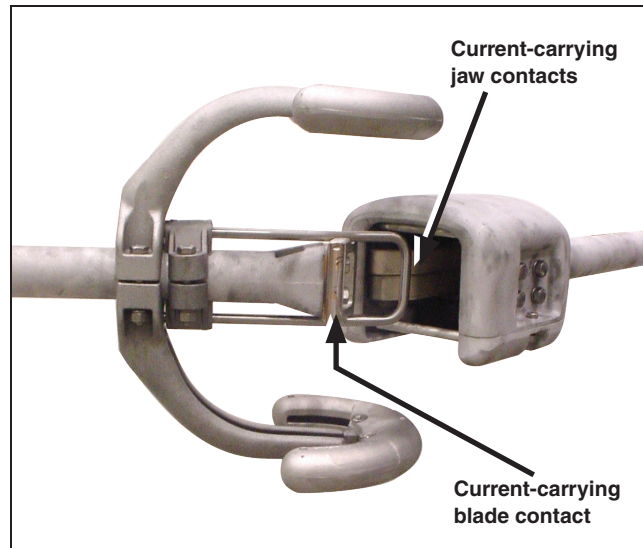

Figure 6. Position of disconnect required for performing overtravel adjustment on center-break Style Mark V or Mark IV Circuit-Switchers.

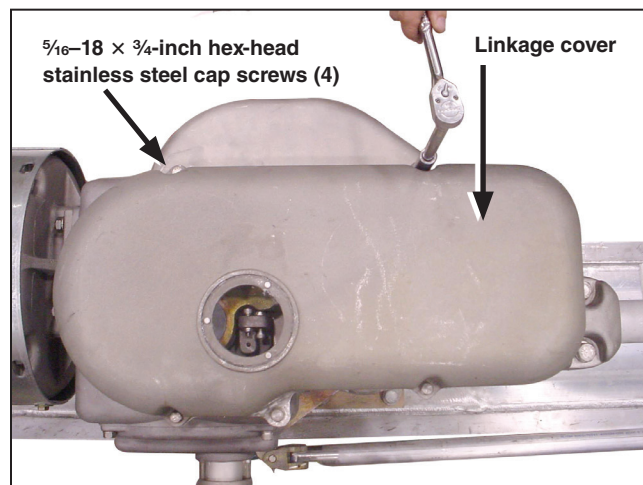

Figure 7. Removing the linkage cover.

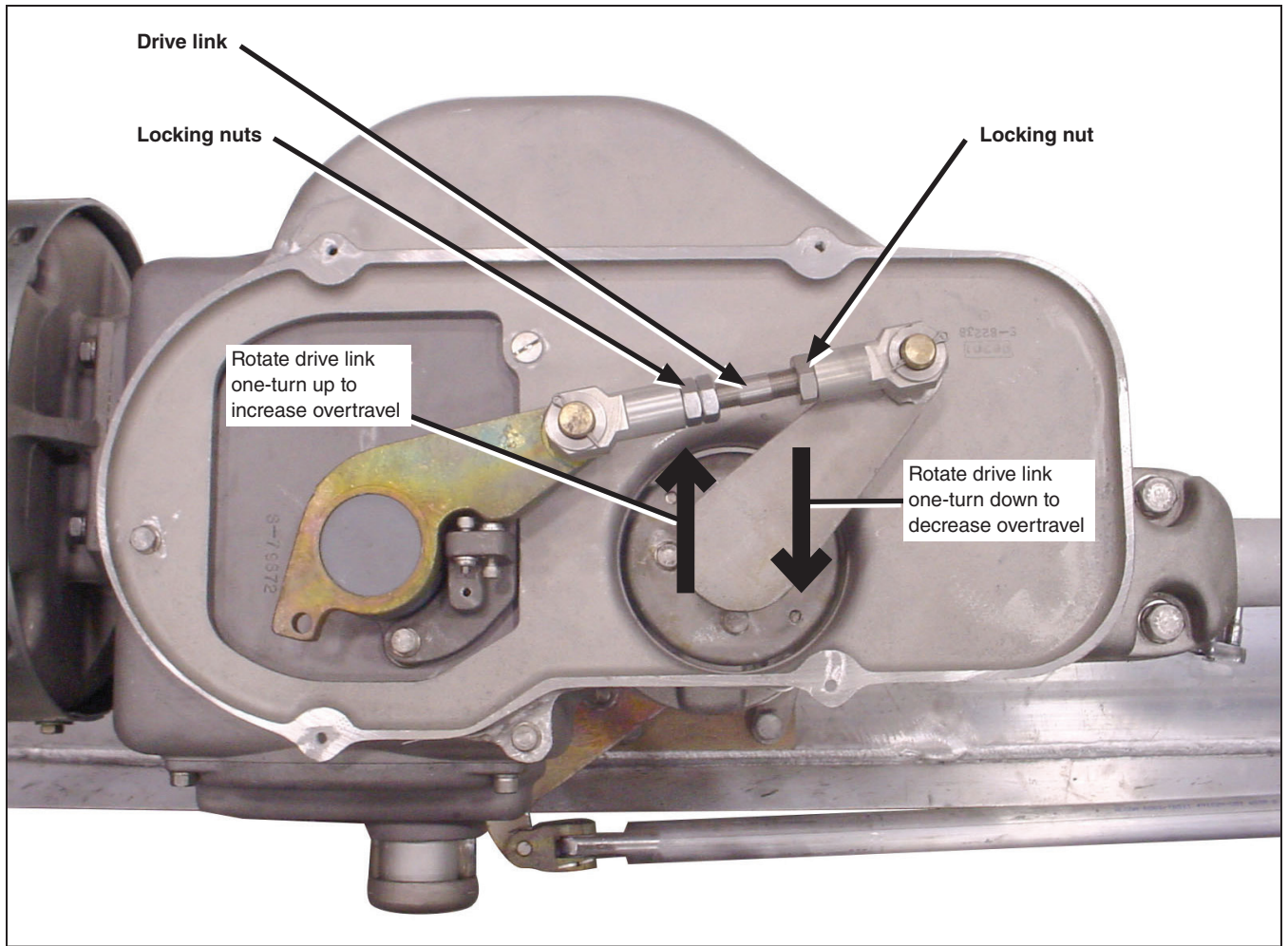

Figure 8. Overtravel adjustment on center-break style circuit-switchers.

Measuring the Latch Gap for Mark V Circuit-Switchers

 **DANGER**

De-energize the circuit-switcher, isolate it from all high-voltage sources, and ground it at all six terminals before proceeding with latch-gap measurement.

Failure to properly de-energize and ground the circuit-switcher will result in serious personal injury or death.

Note: For latch-gap measurement instructions for 69-kV single-gap Mark V and Mark IV Circuit-Switchers in ungrounded capacitor switching applications only, refer to S&C Instruction Sheet 711-515.

To measure the latch gap, complete the following steps:

STEP 1. Close the switch by cranking the manual operating handle.

STEP 2. Slowly crank the manual operating handle and listen for simultaneity of tripping of the interrupters. From the point where one interrupter trips, no more than 40 degrees of rotation should be required before the other two interrupters trip.

If no more than 40 degrees of rotation are required, latch-gap adjustment is not required, continue with Step 3. If excessive rotation is required to trip the interrupters, however, latch-gap adjustment is necessary complete the adjustment procedure Adjusting the Latch Gap on Mark IV and Mark V Circuit-Switchers on page 15 .

STEP 3. If no adjustment is required, replace the brain cover(s) using the locating pin on each brain housing (if furnished) as a positioning guide. See Figure 9 on page 16. Be careful not to damage the O-ring seal.

Secure each brain cover using $\frac{3}{8}$ -16 \times 1 $\frac{1}{4}$ -inch hex-head stainless steel cap screws (taking care to replace the special shoulder bolts (if present) in their correct positions) and, if applicable, replace the shunt-trip operating shaft weather-sealing boot.

STEP 4. Replace the fuseholder for the motor circuit and/or the fuseholder for the shunt-trip circuit. The switch can now be returned to service.

Adjusting the Latch Gap on Mark IV and Mark V Circuit-Switchers

DANGER

De-energize the circuit-switcher, isolate it from all high-voltage sources, and ground it at all six terminals before proceeding with latch-gap adjustment.

Failure to properly de-energize and ground the circuit-switcher will result in serious personal injury or death.

To adjust the latch gap on Mark IV and Mark V Circuit-Switchers, complete the following steps:

- STEP 1.** Use the manual operating handle to fully open and then reclose the switch. Now, slowly turn the manual operating handle, just until all three interrupters are heard to trip. Note which interrupter is the last to trip.
- STEP 2.** *On vertical-break style or integer-style circuit-switchers:* Continue to slowly turn the manual operating handle a few more degrees- just to the point where the disconnect current-carrying tongue contacts disengage their respective current carrying jaw contacts. See Figure 4 on page 10.
- On center-break style circuit-switchers:* Continue to slowly turn the manual operating handle a few more degrees, just to the point where the current-carrying tongue contacts on the terminal-end blade assemblies disengage the current-carrying jaw contacts on the interrupter-end blade assemblies. See Figure 6 on page 12.
- STEP 3.** With the switch in this position, remove, at the brain of the last pole-unit to trip, the four $\frac{3}{8}$ -16 \times 1 $\frac{1}{4}$ -inch hex-head stainless steel cap screws (two are special shoulder bolts) from the brain cover. See Figure 9 on page 16. Retain the screws.
- On shunt-trip-equipped circuit-switchers:* Slide down the silicone-rubber weather sealing boot to expose the shunt-trip operating shaft tongue-and-groove joint.
- STEP 4.** Use a small screwdriver, if necessary, to pry the brain cover loose, but be careful not to damage the internal O-ring seal.

On shunt-trip-equipped circuit-switchers: it will be necessary to rotate the cover counterclockwise to disengage it from the shunt trip operating shaft.

- STEP 5.** Adjust the latch gap.

WARNING

To prevent serious injury to hands resulting from inadvertent tripping of the brain, do not adjust the latch-gap adjusting screw with the disconnect opened further than shown in Figure 4 on page 10 or Figure 6 on page 12, since the stored-energy springs in the brain may be charged.

Using a $\frac{1}{4}$ -inch Allen wrench socket attached to a $\frac{3}{8}$ -inch socket wrench or a extended shaft T-style Allen wrench, turn the socket-head latch gap adjusting screw approximately $\frac{1}{2}$ turn clockwise. See Figure 10 on page 17. This latch-gap adjustment will result in earlier tripping of the interrupter.

- STEP 6.** Repeat Step 1 through Step 5 until the requisite degrees of rotation of the manual operating handle from the point where one interrupter trips to the point where the other two interrupters trip is less than or equal to 40 degrees. To avoid multiple iterations of this procedure, do not adjust the brains at more than two of the pole-units.
- STEP 7.** Replace the brain cover(s) using the locating pin on each brain housing (if furnished) as a positioning guide. See Figure 9 on page 16. Be careful not to damage the O-ring seal.
- Secure each brain cover using $\frac{3}{8}$ -16 \times 1 $\frac{1}{4}$ -inch hex-head stainless steel cap screws (taking care to replace the special shoulder bolts, if present, in their correct positions) and, if applicable, replace the shunt-trip operating shaft weather-sealing boot.
- STEP 8.** Replace the fuseholder for the motor circuit and/or the fuseholder for the shunt-trip circuit. The switch can now be returned to service.

Latch-Gap Measurement and Adjustment

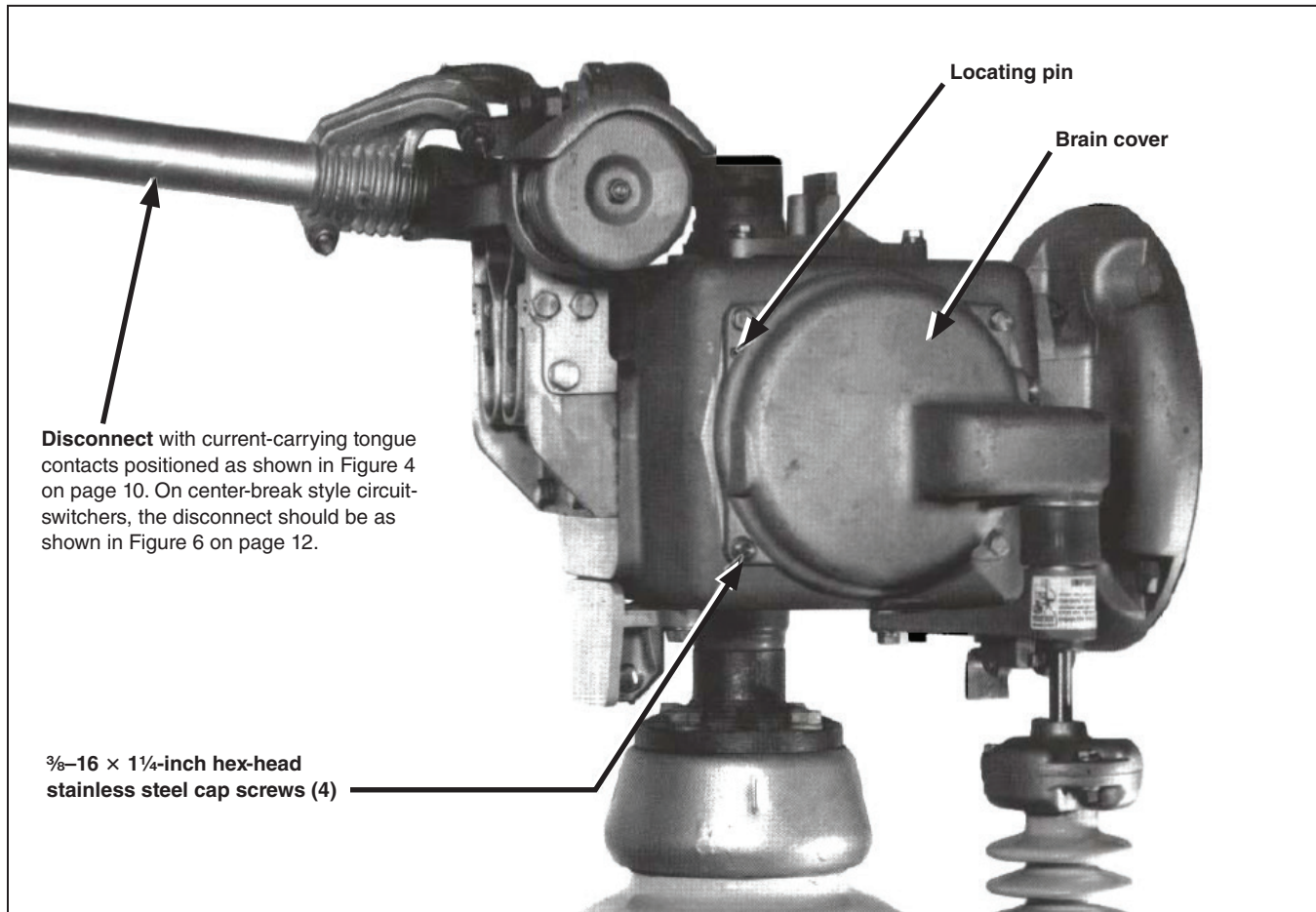

Figure 9. Removing brain cover on vertical-break style or integer style Mark V or Mark IV Circuit-Switcher. Center-break style Mark V and Mark IV Circuit-Switchers are similar.

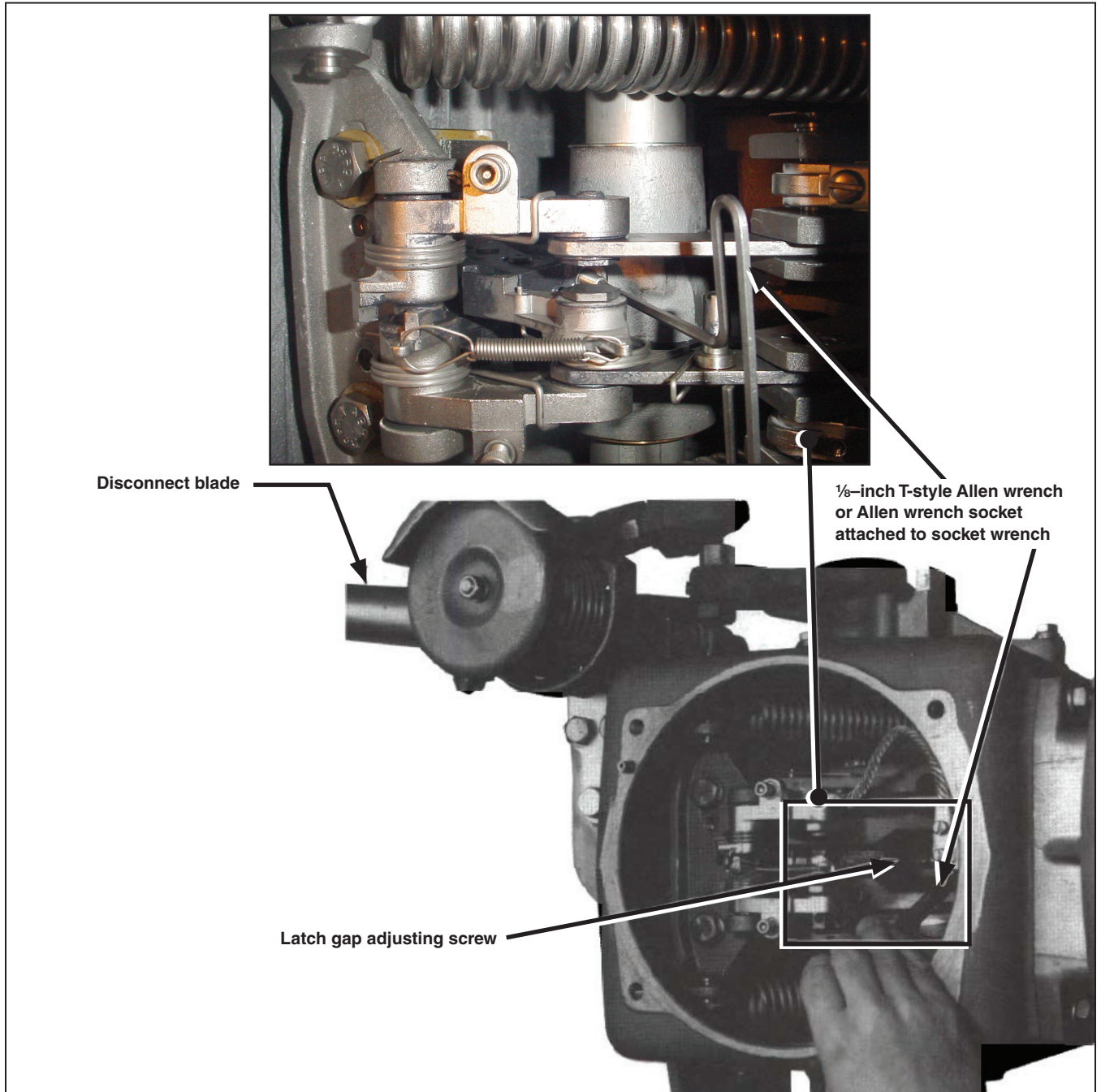

Figure 10. Adjusting latch gap on vertical-break Style or Integer Style Mark V or Mark IV Circuit-Switcher. Center-break Mark V and Mark IV Circuit-Switchers are similar.