

# Installation

## Table of Contents

<b>Introduction</b> .....	<b>2</b>	<b>Shipping and Handling</b> .....	<b>5</b>
Qualified Persons .....	2	Inspection .....	5
Read This Instruction Sheet .....	2	Packing .....	5
Retain This Instruction Sheet .....	2	Storage .....	5
Proper Application.....	2	<b>Installation</b> .....	<b>6</b>
<b>Safety Information</b> .....	<b>3</b>	Before Starting .....	6
Understanding Safety-Alert Messages .....	3	Installing the Outboard Bearing Assembly and	
Following Safety Instructions.....	3	Manual Geared Operating Handle.....	6
Replacement Instructions and Labels .....	3	Installing the Vertical Operating Pipe .....	8
<b>Safety Precautions</b> .....	<b>4</b>	Installing the Interphase Drive Train .....	9
		Installing the Grounding Straps .....	12
		Checking Overtoggle and Adjusting the	
		Power Train.....	13
		<b>Inspection Recommendations</b> .....	<b>18</b>



# Introduction

---

## Qualified Persons

### **WARNING**

Only qualified persons knowledgeable in the installation, operation, and maintenance of overhead and underground electric distribution and transmission equipment, along with all associated hazards, may install, operate, and maintain the equipment covered by this publication. A qualified person is someone trained and competent in:

- The skills and techniques necessary to distinguish exposed live parts from nonlive parts of electrical equipment
- The skills and techniques necessary to determine the proper approach distances corresponding to the voltages to which the qualified person will be exposed
- The proper use of special precautionary techniques, personal protective equipment, insulated and shielding materials, and insulated tools for working on or near exposed energized parts of electrical equipment

These instructions are intended only for such qualified persons. They are not intended to be a substitute for adequate training and experience in safety procedures for this type of equipment.

## Read This Instruction Sheet

### **NOTICE**

Thoroughly and carefully read this instruction sheet and all materials included in the product's instruction handbook before installing or operating the optional grounding switch on a 230 kV Mark V Circuit-Switcher. Become familiar with the Safety Information on page 3 and Safety Precautions on page 4. The latest version of this publication is available online in PDF format at [sandc.com/en/contact-us/product-literature/](http://sandc.com/en/contact-us/product-literature/).

## Retain This Instruction Sheet

This instruction sheet is a permanent part of the Mark V Circuit-Switcher. Designate a location where users can easily retrieve and refer to this publication.

## Proper Application

### **WARNING**

The equipment in this publication is only intended for installation on a center-break 230 kV Mark V Circuit-Switcher. The application must be within the ratings furnished for the equipment. Ratings for the Mark V Circuit-Switcher are listed in the ratings table in Specification Bulletin 711-31. The ratings are also on the nameplate affixed to the product.

**Understanding Safety-Alert Messages**

Several types of safety-alert messages may appear throughout this instruction sheet and on labels and tags attached to the product. Become familiar with these types of messages and the importance of these signal words:

<b>⚠ DANGER</b>
“DANGER” identifies the most serious and immediate hazards that will likely result in serious personal injury or death if instructions, including recommended precautions, are not followed.

<b>⚠ WARNING</b>
“WARNING” identifies hazards or unsafe practices that can result in serious personal injury or death if instructions, including recommended precautions, are not followed.

<b>⚠ CAUTION</b>
“CAUTION” identifies hazards or unsafe practices that can result in minor personal injury if instructions, including recommended precautions, are not followed.

<b>NOTICE</b>
“NOTICE” identifies important procedures or requirements that can result in product or property damage if instructions are not followed.

**Following Safety Instructions**

If any portion of this instruction sheet is unclear and assistance is needed, contact the nearest S&C Sales Office or S&C Authorized Distributor, or call the S&C Global Support and Monitoring Center at 1-888-762-1100. Telephone numbers are also listed on S&C’s website, [sandc.com](http://sandc.com).

<b>NOTICE</b>	
Read this instruction sheet thoroughly and carefully before installing the grounding switch.	

**Replacement Instructions and Labels**

If additional copies of this instruction sheet are required, contact the nearest S&C Sales Office, S&C Authorized Distributor, S&C Headquarters, or S&C Electric Canada Ltd.

It is important any missing, damaged, or faded labels on the equipment be replaced immediately. Replacement labels are available by contacting the nearest S&C Sales Office, S&C Authorized Distributor, S&C Headquarters, or S&C Electric Canada Ltd.

### DANGER



**Mark V Circuit-Switchers operate at high voltage. Failure to observe the precautions below will result in serious personal injury or death.**

Some of these precautions may differ from your company's operating procedures and rules. Where a discrepancy exists, follow your company's operating procedures and rules.

1. **QUALIFIED PERSONS.** Access to Mark V Circuit-Switchers must be restricted only to qualified persons. See the "Qualified Persons" section on page 2.
2. **SAFETY PROCEDURES.** Always follow safe operating procedures and rules.
3. **PERSONAL PROTECTIVE EQUIPMENT.** Always use suitable protective equipment, such as rubber gloves, rubber mats, hard hats, safety glasses, and flash clothing, in accordance with safe operating procedures and rules.
4. **SAFETY LABELS.** Do not remove or obscure any of the "DANGER," "WARNING," "CAUTION," or "NOTICE" labels.
5. **OPERATING MECHANISM AND BASE.** Mark V Circuit-Switchers contain fast moving parts that can severely injure fingers. Do not remove or disassemble operating mechanisms or remove access panels unless directed by S&C Electric Company.
6. **ENERGIZED COMPONENTS.** Always consider all parts live until de-energized, tested, and grounded. Voltage levels can be as high as the peak line-to-ground voltage last applied to the circuit-switcher. Circuit-switchers that have been installed near energized lines should be considered live until tested and grounded.
7. **GROUNDING.** The Mark V Circuit-Switcher must be connected to a suitable earth ground at the base of the utility pole, substation ground system, or to a suitable building ground for testing, before energizing the switch and at all times when energized.  
The ground wire(s) must be bonded to a system neutral, if present. If the system neutral is not present, proper precautions must be taken to ensure the local earth ground, or building ground, cannot be severed or removed.
8. **SWITCH POSITION.** Always confirm the **Open/Close** position of each switch.
  - Switches and terminal pads may be energized from either side.
  - Switches and terminal pads may be energized with the switches in any position.
9. **MAINTAINING PROPER CLEARANCE.** Always maintain proper clearance from energized components.
10. **GROUNDING SWITCH.** Only operate the grounding switch when the Mark V Circuit-Switcher is in the **Open** position. The grounding switch is operated via an S&C Manual Geared Operating Handle installed near the base of the grounding switch. "Partway" opening or closing is undesirable. Once the associated circuit-switcher is in the **Open** position, operate the grounding switch until the grounding switch blades are 90 degrees perpendicular to the pole-unit bases.

## Inspection

Examine the shipment for external evidence of damage as soon after receipt as possible, preferably before removal from the carrier's conveyance. Check the bill of lading to make sure all listed shipping skids, crates, cartons, and containers are present.

If there is visible loss and/or damage:

1. Notify the delivering carrier immediately.
2. Ask for a carrier inspection.
3. Note condition of shipment on all copies of the delivery receipt.
4. File a claim with the carrier.

If concealed damaged is discovered:

1. Notify the delivering carrier within 15 days of receipt of shipment.
2. Ask for a carrier inspection.
3. File a claim with the carrier.

Also, notify S&C Electric Company in all instances of loss or damage.

## Packing

An S&C erection drawing will be found in a water-resistant envelope attached to one of the three pole-units. The grounding switch consists of a manual three-pole group-operated grounding switch, with flexible straps for current transfer at the hinge-end of the blades, and with blades perpendicular to the pole-unit bases when in the open position. When furnished as original equipment with the circuit-switcher, inclusion of the accessory is designated by the addition of the suffix "-G4" to the circuit-switcher catalog number.

If the switch is supplied with the catalog option "-A" for pre-assembly. The insulators will be pre-installed on the pole-units and the jaw contact and grounding switch blade will be pre-installed and adjusted. Handle the skid carefully. A crane is required to remove the crated switch from its conveyance. See Figure 1. Eyebolts are provided.

## Storage

If the grounding switch components must be stored before installation, keep them in a clean, dry, corrosion-free area to protect them from damage. Make sure each skid rests firmly on the ground and is reasonably level. Shoring under the skids may be necessary if the ground is uneven.

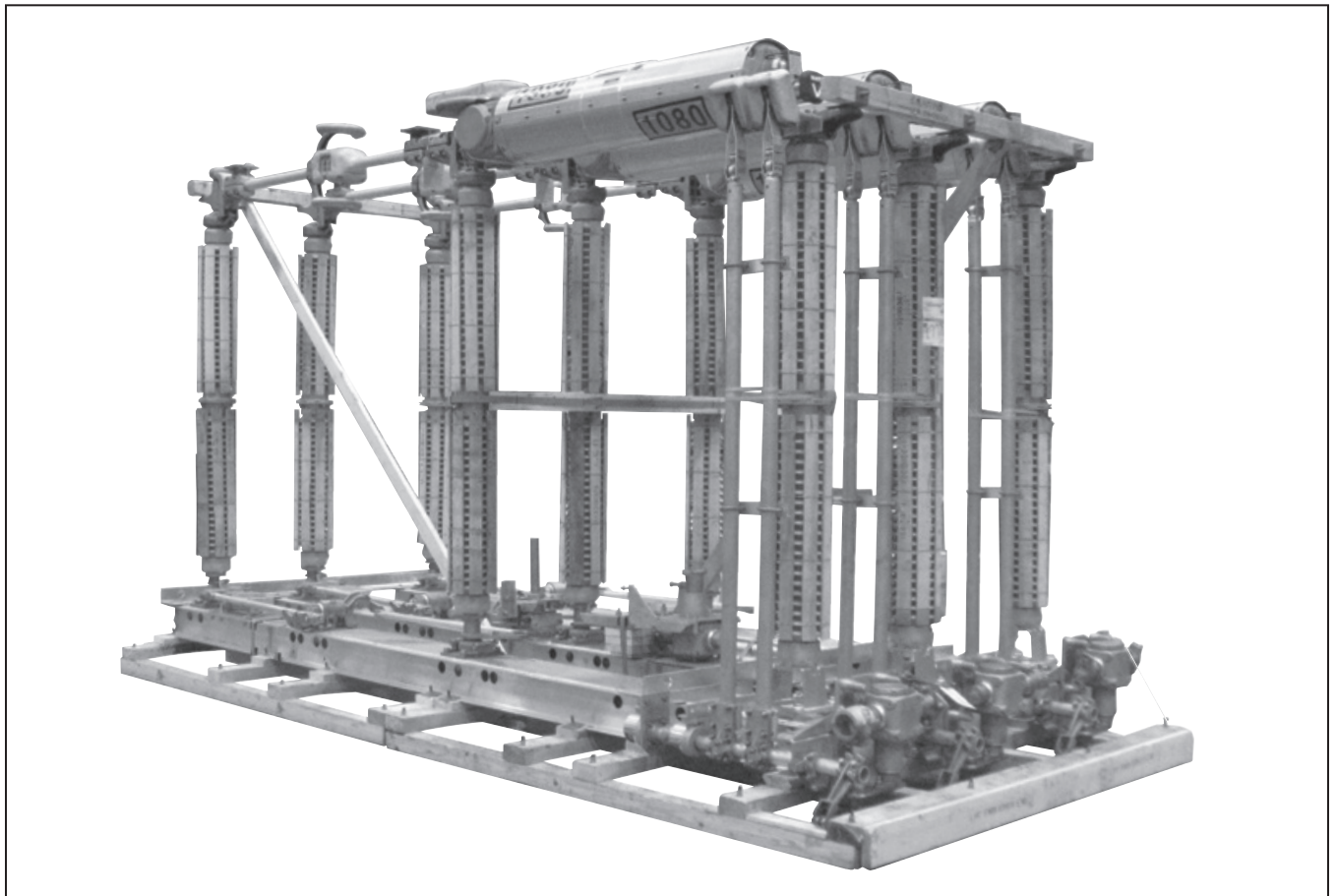

Figure 1. Remove the crated switch from its conveyance.

# Installation

## Before Starting

These instructions are for field assembly and installation of the S&C Grounding Switch, rated 80,000 amperes momentary, for use with center-break S&C Mark V Circuit-Switchers rated 230 kV. Install the remaining grounding switch components only after the circuit-switcher and its power train have been completely installed and adjusted.

Unless supplied on S&C Mounting Pedestals, the Mark V Circuit-Switcher is engineered to order and the exact configuration of the grounding switch will vary depending on the mounting structure. Supplemental dimensional details for the grounding switch installation are included on the erection drawing furnished with the circuit-switcher. Study the erection drawing carefully to determine the overall configuration and the arrangement of components.

### NOTICE

#### Installing Couplings with Piercing Set Screws

This equipment uses piercing set screws to couple the operating handle to the operating pipe, to secure the interphase operating pipe sections, and to provide stability to couplings joining one or more lengths of pipe.

Before assembling a coupling joint, back the piercing set screws out of the coupling so that the tips do not protrude into the body of the coupling. This ensures that the coupling's clamp screws can be fully tightened.

**Note:** If a grounding switch is to be added to an existing circuit-switcher installation, the components should be assembled in accordance with the special drawings provided.

## Installing the Outboard Bearing Assembly and Manual Geared Operating Handle

Proceed as follows:

- STEP 1.** Mount the outboard bearing assembly on the circuit-switcher pole-unit base in the position shown on the erection drawing. See Figure 2. Support brackets will mount underneath the pole-unit base. Certain circuit-switcher configurations use a gearbox instead of or in addition to an outboard bearing assembly; in this case, the erection drawing will show where to install the gearbox. See Figure 3 on page 7.

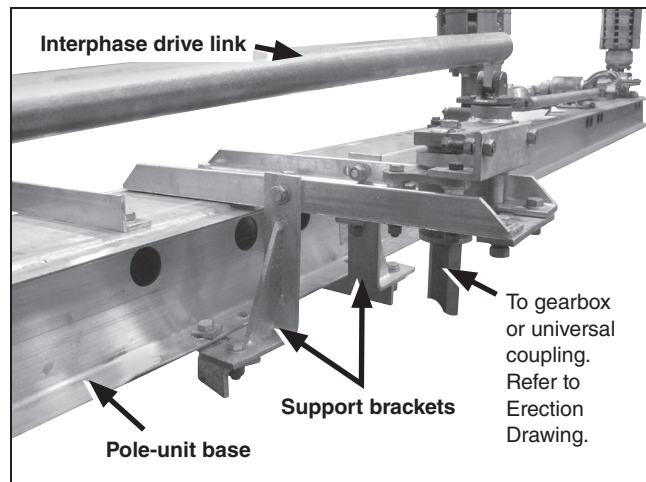

Figure 2. Outboard bearing assembly.

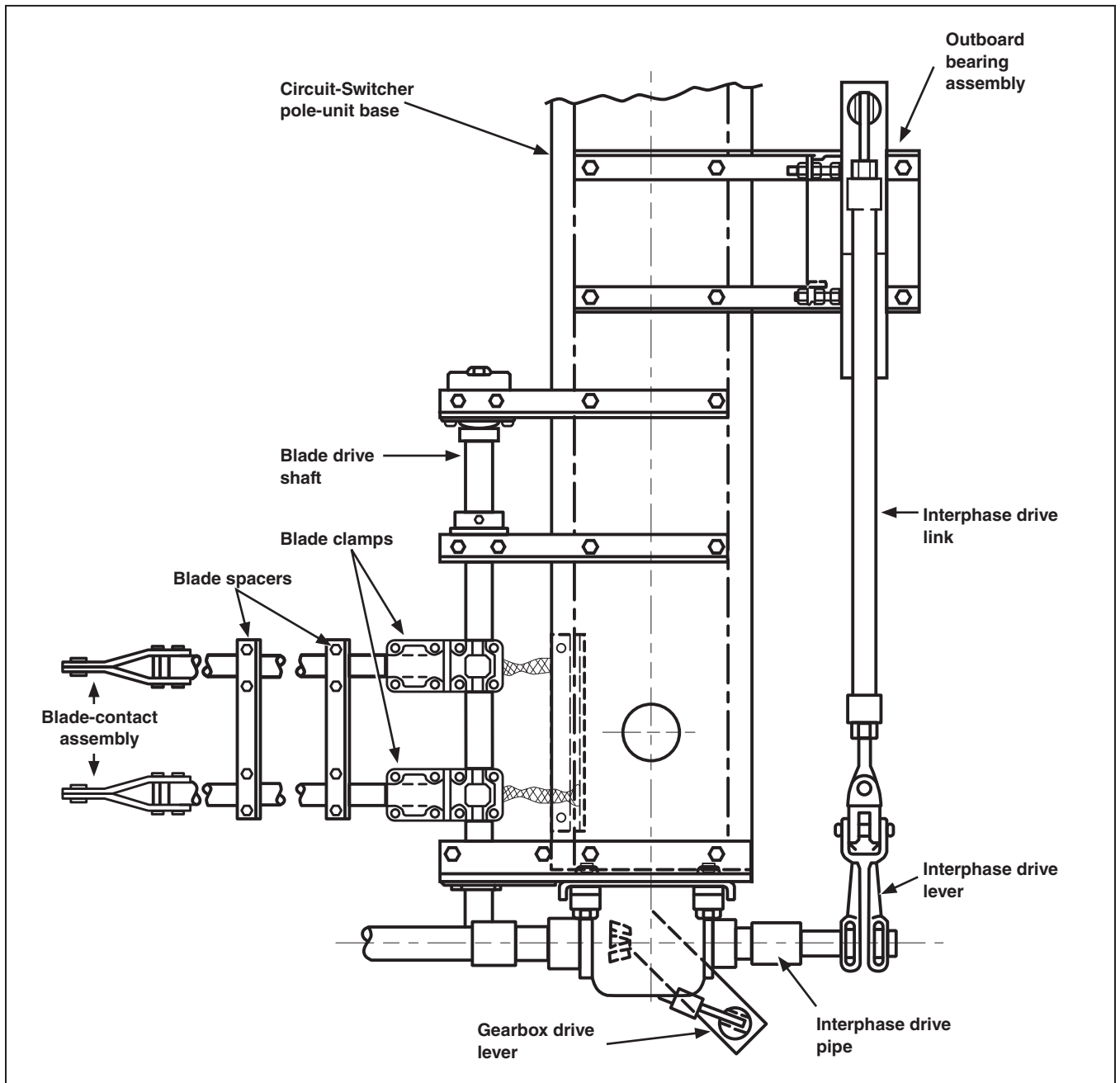

Figure 3. Typical three-pole grounding switch configuration, shown in Open position.

## Installation

**STEP 2.** Mount the S&C Manual Geared Operating Handle to the mounting structure in the position shown on the erection drawing using the supplied  $\frac{5}{8}$ -inch galvanized hardware. Mounting angles are provided on the rear of the enclosure. See Figure 4 and Figure 5. Refer to the detailed instructions in S&C Instruction Sheet 719-530 for installing and adjusting the S&C Manual Geared Operating Handle.

### Installing the Vertical Operating Pipe

**STEP 1.** Remove or loosen the universal or flexible coupling clamp bolts on the coupling below the outboard bearing assembly (or gearbox). See Figure 4.

**STEP 2.** Install the vertical-operating-pipe section (or sections) and, if required, the guide bearing assembly (or assemblies) between the universal coupling at the outboard bearing assembly (or gearbox) and the universal coupling or flexible coupling at the manual geared operating handle. See Figure 5. Work from the universal coupling on the outboard bearing assembly (or gearbox) downward to the universal or flexible coupling on the manual geared operating handle.

#### NOTICE

If more than one vertical operating pipe section is specified, a universal coupling is used to join the upper pipe section to the next lower pipe section. Any intermediate pipe sections are joined with rigid couplings.

Torque the clamp bolts on all couplings to final tightness. Then, tighten the piercing set screws, piercing the pipe, and continue turning until a firm resistance is felt.

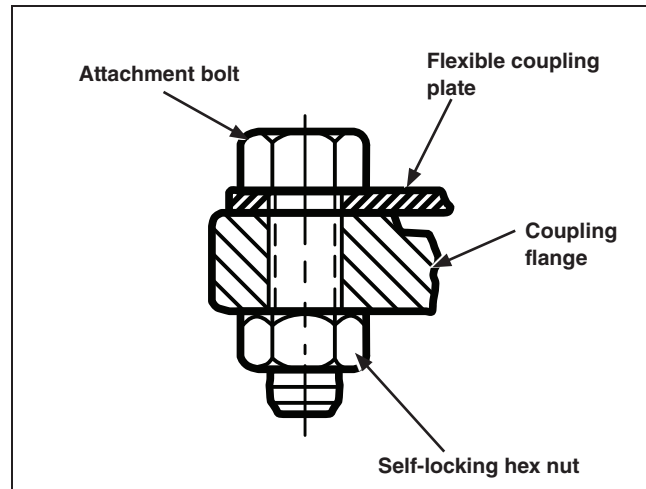

Figure 4. Attachment bolt detail.

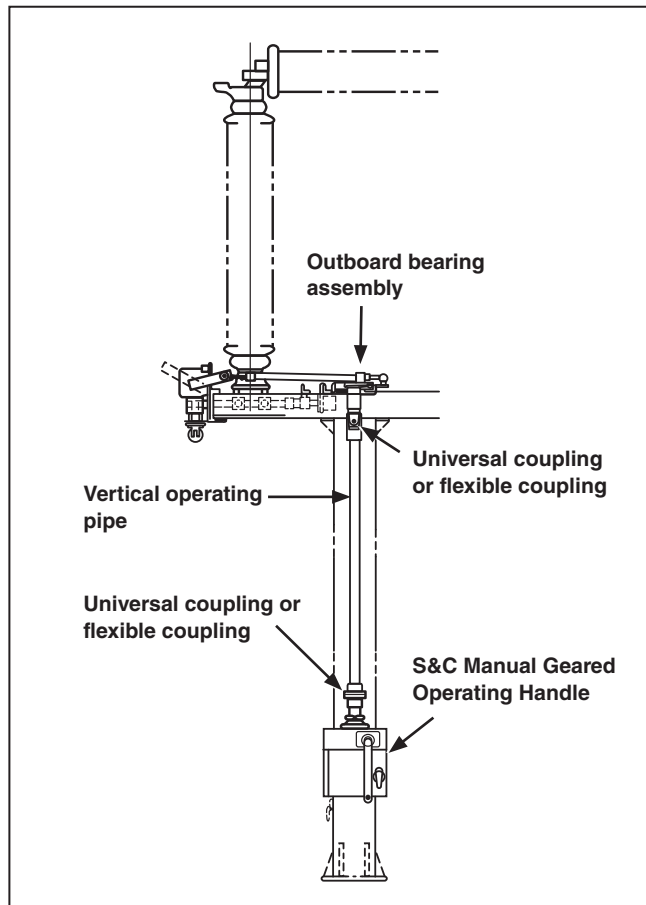

Figure 5. Vertical operating pipe and S&C Manual Geared Operating Handle.

### Installing the Interphase Drive Train

The gearbox, gearbox drive lever, blade clamp, and blade drive shaft are all factory-installed on each pole-unit. See Figure 6. The piercing set screws securing the blade clamps and the gearbox drive lever to the drive pipe are fully-set at the factory. A rigid or flexible coupling is pre-installed on the output ends of each gearbox. See Figure 7 for an illustration of a typical grounding switch drive train.

Install each interphase operating pipe section into its rigid coupling and then into its flexible coupling as follows:

- STEP 1.** Remove or loosen the coupling clamp if necessary. Each pipe is furnished pre-cut to the correct length. Tighten the clamp bolts but do not tighten the piercing set screws at this time. See Figure 7.

If more than one pipe section is required for each phase-to-phase span, connect the sections with the provided rigid pipe-to-pipe couplings.

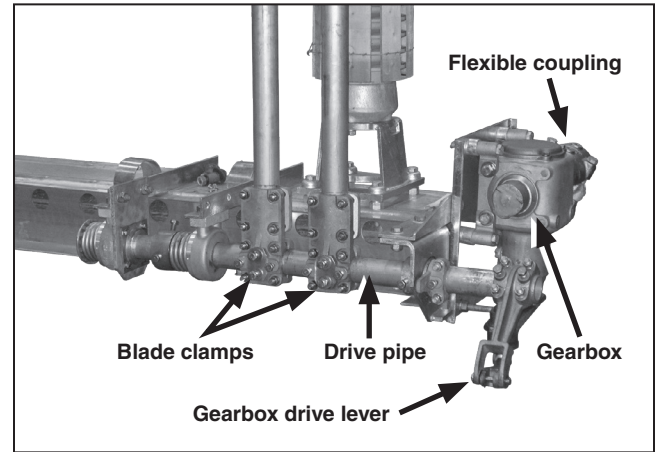

Figure 6. Grounding switch gearbox and drive assembly.

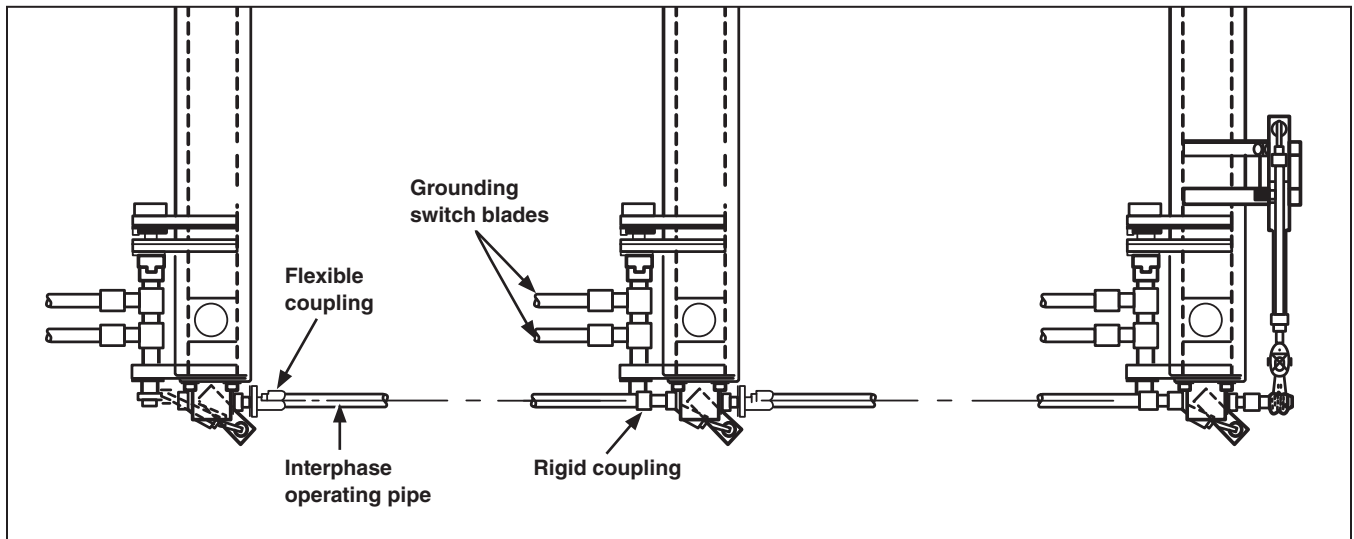

Figure 7. Top view of grounding switch drive train with switch blades in Open position.

## Installation

**STEP 2.** Install the interphase drive pipe into its rigid coupling. See Figure 8. The interphase drive pipe will attach to the side of the gearbox closest to where the outboard bearing assembly is mounted.

**STEP 3.** Pull the switch blades to bring them into the fully open position. See Figure 7 on page 9. Then, operate the manual geared operating handle to the open position. Install the interphase drive lever onto the interphase drive pipe as shown in Figure 9. Do not tighten the piercing set screws at this time.

Tighten the clamp bolts equally so that they pull down evenly.

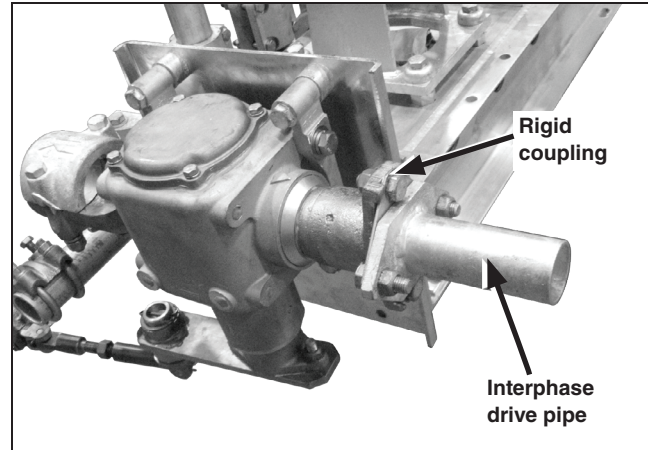

Figure 8. Rigid coupling and interphase drive pipe.

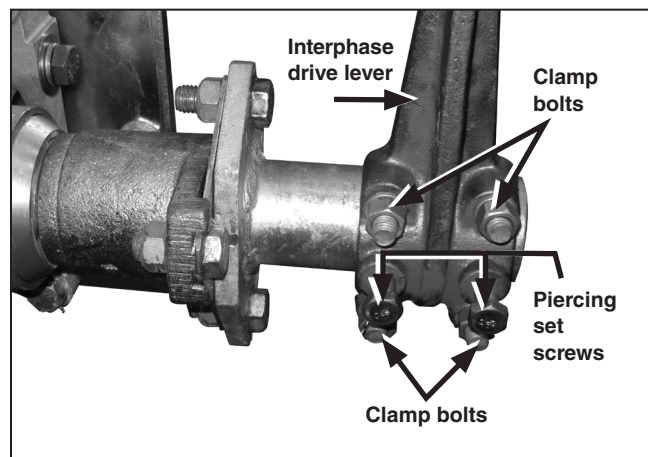

Figure 9. Interphase drive lever.

**STEP 4.** Install the interphase drive link between the adjustable clevis assembly on the outboard bearing assembly and the interphase drive lever using the pins and cotter pins supplied. See Figure 10 and Figure 11 and Figure 3 on page 7. Loosen and turn the interphase drive lever until a secure connection with the pin on the interphase drive link can be made. See Figure 9 on page 10.

When the interphase drive link is installed, tighten the clamp bolts and operate the switch open and closed several times. The blades should open to an approximate 90° angle, and fully-rest against the stop roller inside the jaw contact when closed.

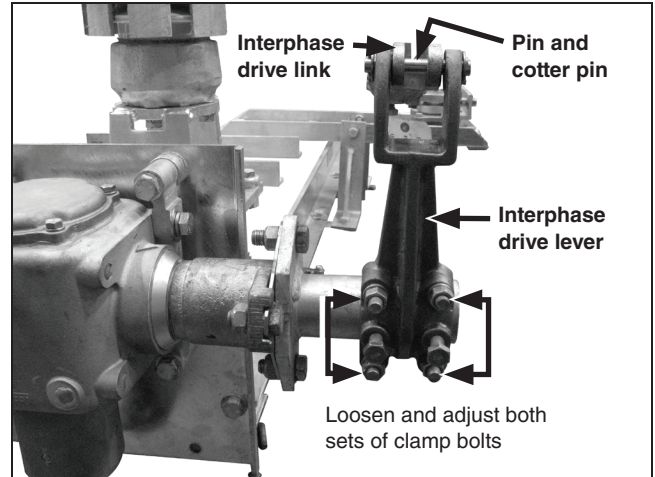

Figure 10. Install interphase drive link.

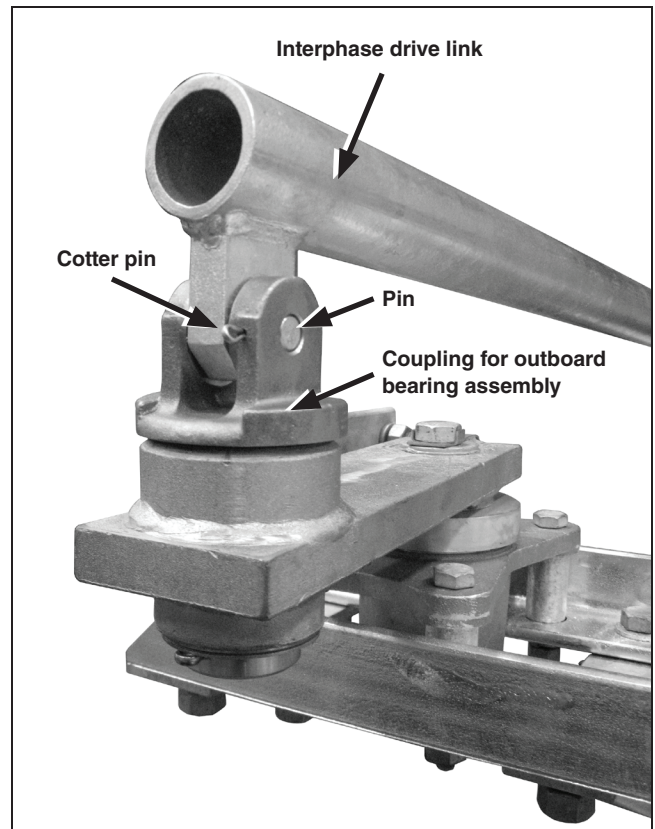

Figure 11. Interphase drive link connection to outboard bearing assembly.

# Installation

## Installing the Grounding Straps

To install the grounding straps, complete the following steps:

- STEP 1.** At each circuit-switcher pole-unit, attach the grounding strap mounting angle to the bottom of the pole-unit base in the position shown on the erection drawing. See Figure 12.
- (a) Thoroughly wire-brush the aluminum mounting angle.
  - (b) Thoroughly wire-brush the aluminum base of the pole-unit's mating surface.
  - (c) Immediately apply a coat of Penetrox® A (available from Burndy Corporation) or another suitable aluminum connector compound to each brushed surface.
  - (d) Using two  $\frac{1}{2}$ -13  $\times$  2-inch hex-head stainless steel cap screws, flat washers, channel washers, lock washers, and hex nuts, attach the grounding strap mounting angle to the base.
- STEP 2.** Install each grounding strap:
- (a) Thoroughly wire-brush each end of the flexible grounding strap used for current transfer at the hinge-end of each blade assembly. See Figure 13.
  - (b) Also thoroughly wire-brush the mating surfaces on the associated blade clamp and on the grounding strap mounting angle.
  - (c) Immediately apply a coating of Penetrox® A (available from Burndy Corporation) or other suitable aluminum connector compound to each brushed surface.
  - (d) Attach one end of the flexible strap to the blade clamp using two  $\frac{1}{2}$ -13  $\times$  1 $\frac{1}{2}$ -inch hex-head stainless steel cap screws, lock washers, and flat washers.
  - (e) Then attach the other end to the grounding strap mounting angle using two  $\frac{1}{2}$ -13  $\times$  2-inch hex-head stainless steel cap screws, lock washers, and hex nuts.

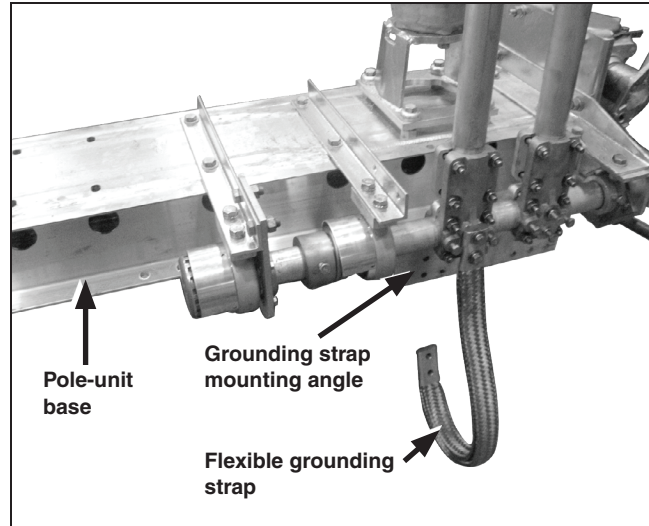

**Figure 12.** Attach the grounding strap mounting angle and attach the flexible grounding strap to the blade clamp assembly.

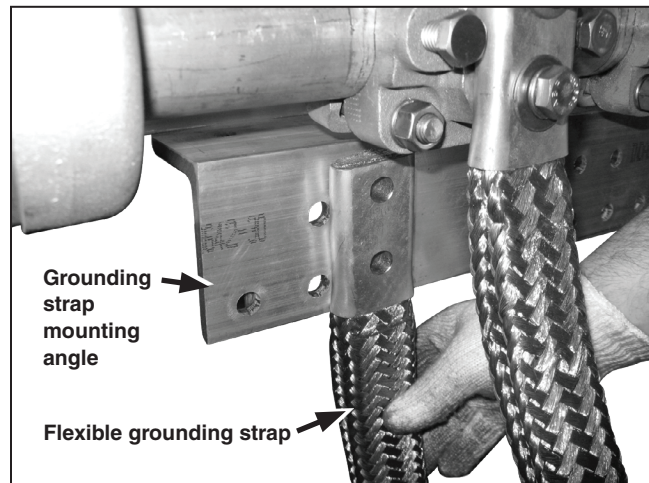

**Figure 13.** Attach the other end of the flexible grounding strap to the mounting angle.

### Checking Overtoggle and Adjusting the Power Train

To check the power train overtoggle, complete the following steps:

- STEP 1.** With the power train still in its fully closed position, make sure that, with the blade drive linkage assembly of each phase in a positive toggle condition—approximately 5 degrees over center—the blade contact assembly is driven firmly against its stop roller. See Figure 14 and Figure 15.
- STEP 2.** Check for proper blade closure by manually pulling the blade assembly away from its closed position. See Figure 16. With a pull-out force of approximately 80 pounds applied at the point indicated, no more than  $\frac{3}{8}$ -inch (9.35 mm) of blade deflection should occur.

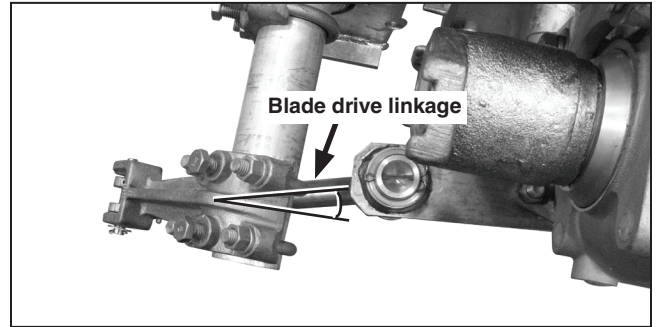

Figure 14. The blade drive linkage in a 5 degree overtoggle.

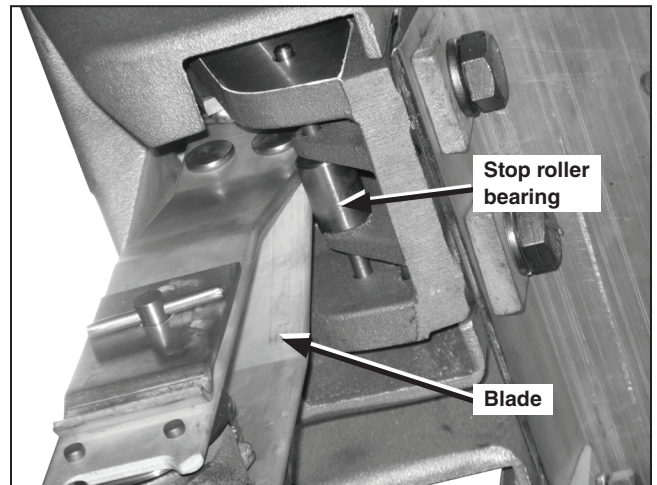

Figure 15. The blade drive linkage in the 5 degree overtoggle position. The blade should be in contact with the roller bearing.

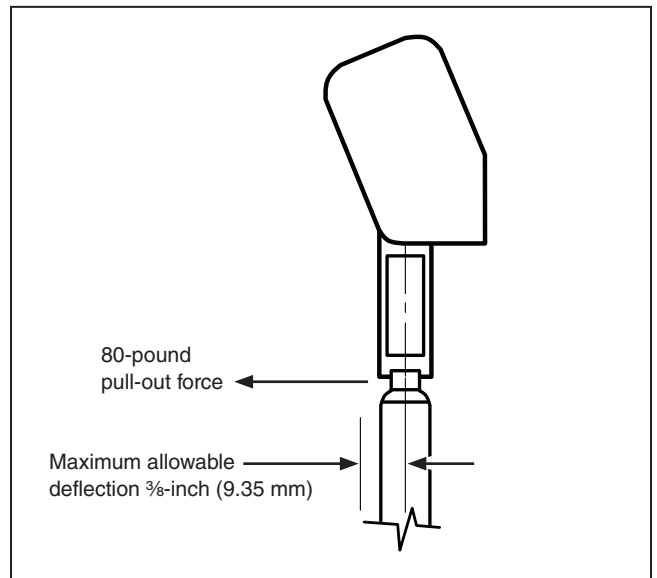

Figure 16. Maximum allowable pull-out force and deflection.

## Installation

**STEP 3.** If greater or lesser drive is needed to fully close blade, increase or decrease the effective length of the blade drive linkage assembly by removing the ½-inch diameter stainless steel pin and cotter pin which connect the blade drive shaft lever to the drive linkage assembly. See Figure 17 and Figure 18.

Loosen the locknut, and then rotate the adjustable link as necessary in half-turn increments. See Figure 19. Then tighten the locknut and replace the pin and cotter pin.

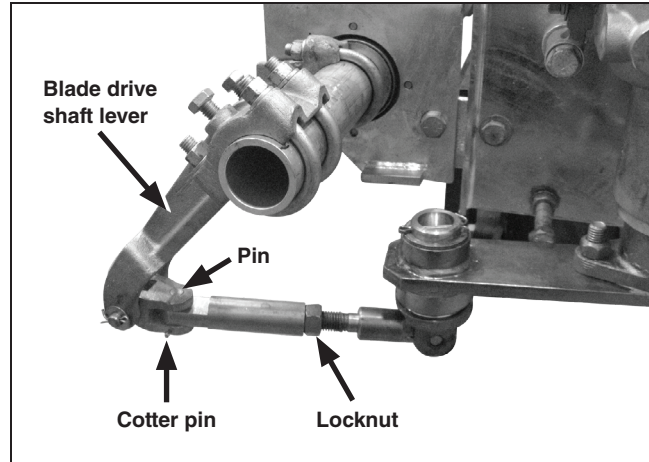

Figure 17. Blade drive linkage assembly.

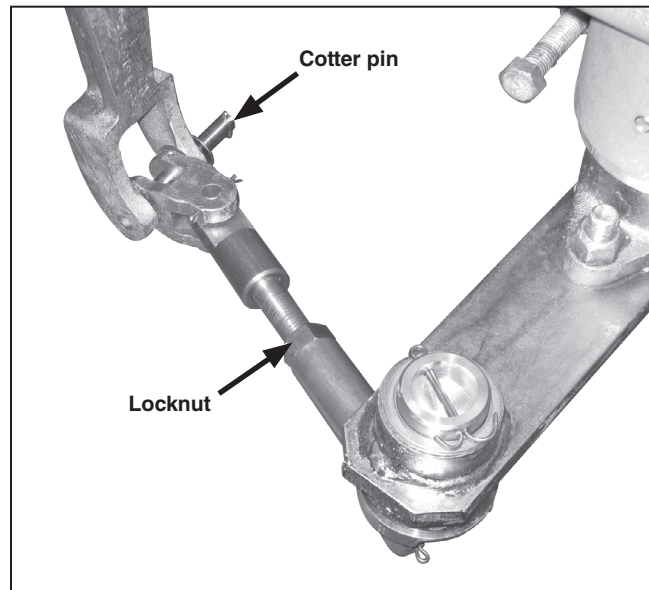

Figure 18. Remove pin and cotter pin and loosen locknut.

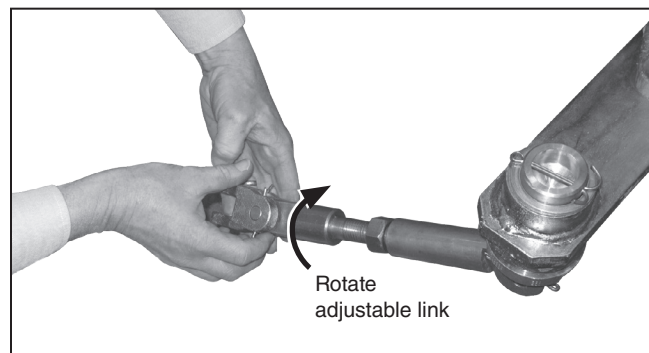
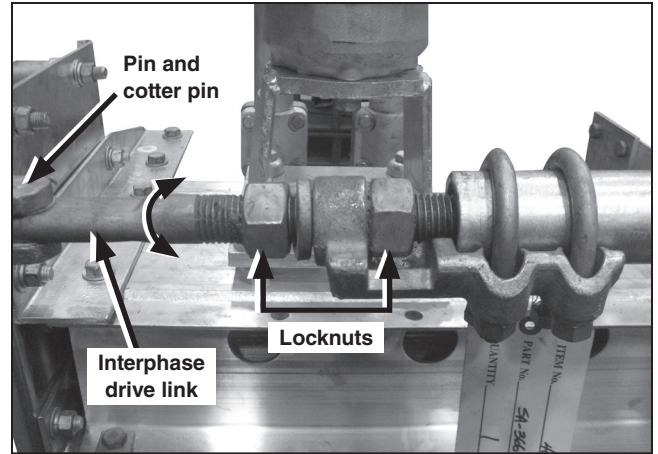

Figure 19. Rotate adjustable link.

**STEP 4.** If greater or lesser travel in the closing direction is needed on all three phases, increase or decrease the effective length of the interphase drive link by means of the adjustable couplings at either end of the interphase drive link.

Loosen the locknuts. Remove the ½-inch diameter pin and cotter pin that secures the interphase drive link to the drive lever. See Figure 20. Rotate the adjustable link in or out as necessary to increase or decrease the length of the link. Replace the pin and cotter pin and re-tighten the locknuts.

**STEP 5.** Using the manual geared operating handle, crank the power train to its fully open position. With the blades horizontal, loosen the clamp bolts and position the blade stop as shown in Figure 21. Then tighten the clamp bolts. When the clamp bolts are tight, tighten the piercing set screw on the blade stop, piercing the pipe, and continue turning until a firm resistance is felt.



**Figure 20.** Adjust the interphase drive link if greater or lesser travel is required for all three phases.

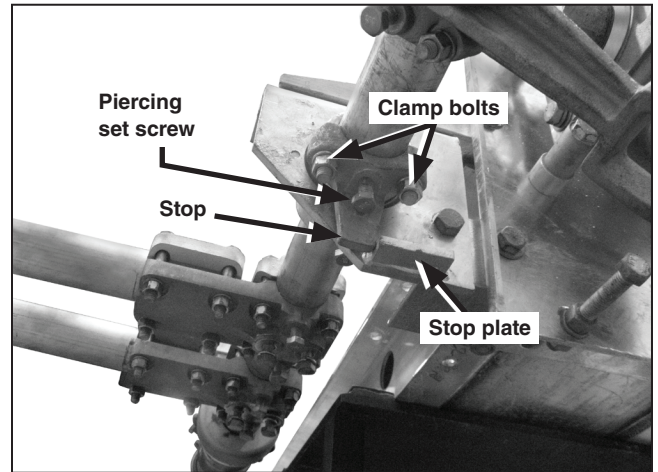

**Figure 21.** Adjust the open stop.

## Installation

### STEP 6. Checking the blade clearance and alignment:

- (a) Operate the switch towards the closed position, stopping when the blade contact assembly first engages the stop roller. See Figure 22. Straighten the blade contact. There should be a  $\frac{1}{2}$  to  $\frac{1}{16}$  inch (12.70 to 1.59 mm) clearance between the tip of the blade-contact and the top of the jaw-contact hood. If the blade clearance is too shallow or too deep, adjust the length of the blade as described in Step 7 on page 17.
- (b) Close the switch. Observe the blade tips as they enter the jaw contacts. See Figure 23. The blades should contact the stop rollers and should be parallel to the jaw contact fingers as they enter the jaw contacts. If one or both of the blade contacts are not parallel, the blade should be rotated. Make the adjustment described in Step 8 on page 17.

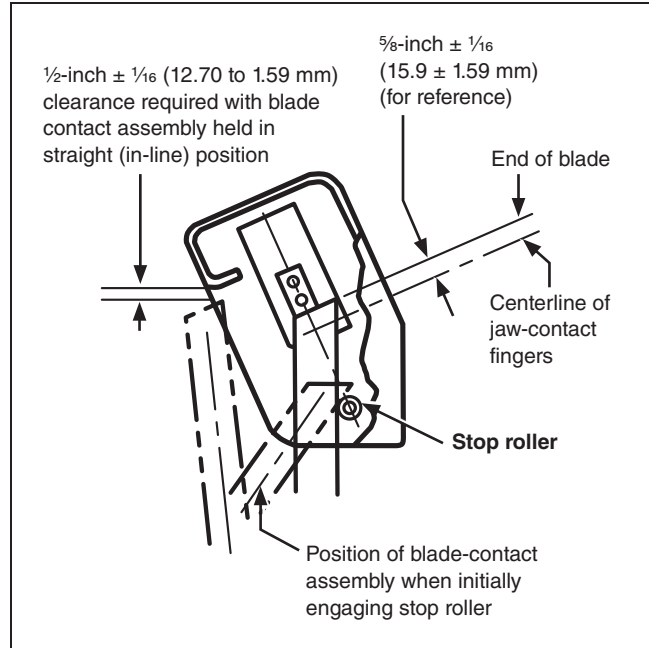

Figure 22. Raise or lower the switch to attain a  $\frac{1}{2}$ -inch clearance with the contact hood.

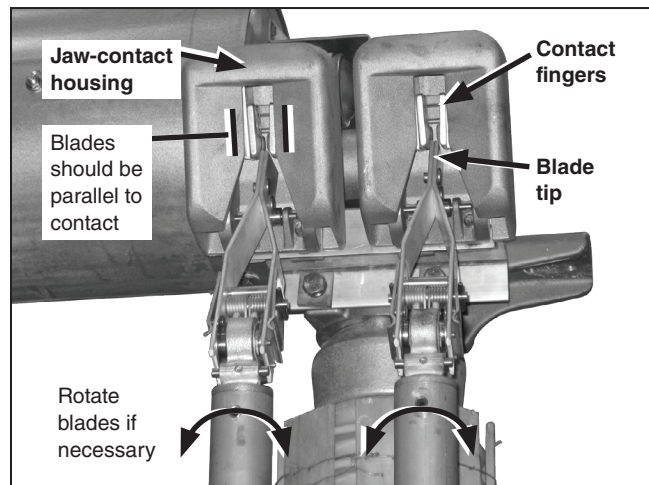
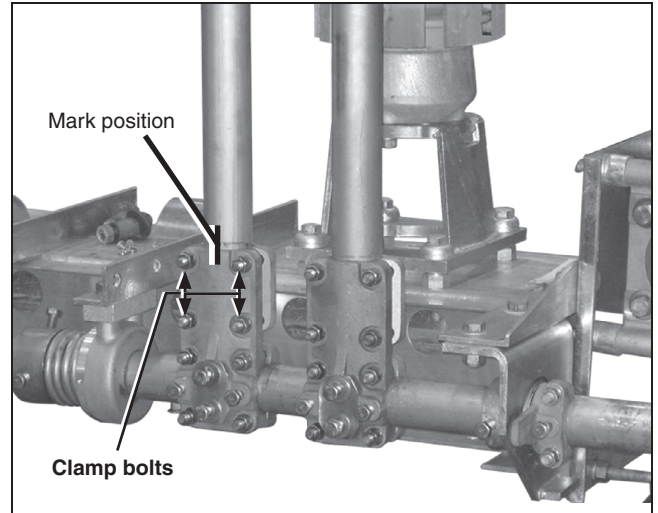

Figure 23. Blade shown during closing. Check that the blade tips are centered on the contact fingers, parallel and not touching the housing.

- STEP 7.** If adjustment of the blade clearance is necessary:
- Mark the radial position of the blade as seen in Figure 24.
  - Loosen the clamp bolts and the blade spacers. (Figure 24 and Figure 25.)
  - Holding the vertical position of the blade to the mark, raise or lower the blade assembly in the blade clamp so that there is a ½-inch (12.70 mm) clearance between the end of the blade-contact assembly and the jaw-contact housing. See Figure 22 on page 16. (This step may require two assembly technicians, one at the base of the blade and one located at the jaw-contact.)
  - Tighten the blade clamp bolts so that the blade pulls down evenly. Reposition and re-tighten the blade spacers as shown in Step 9 if necessary.



**Figure 24.** Mark vertical and horizontal position of blade. Loosen clamp bolts and slide blade into alignment.

- STEP 8.** If the blade is not parallel to the jaw contacts:
- Mark the depth of the blade as it enters the blade clamp. See Figure 24.
  - Loosen the clamp bolts and the blade spacers. See Figure 24 and Figure 25.
  - Holding the depth of the blade to the mark, rotate the blade assembly in the blade clamp until the blade is parallel to the jaw contact fingers. See Figure 23 on page 16. (This step may require two assembly technicians, one at the base of the blade and one located at the jaw-contact.)
  - Tighten the blade clamp bolts so that the blade pulls down evenly. Reposition and re-tighten the blade spacers as shown in Step 9 if necessary.

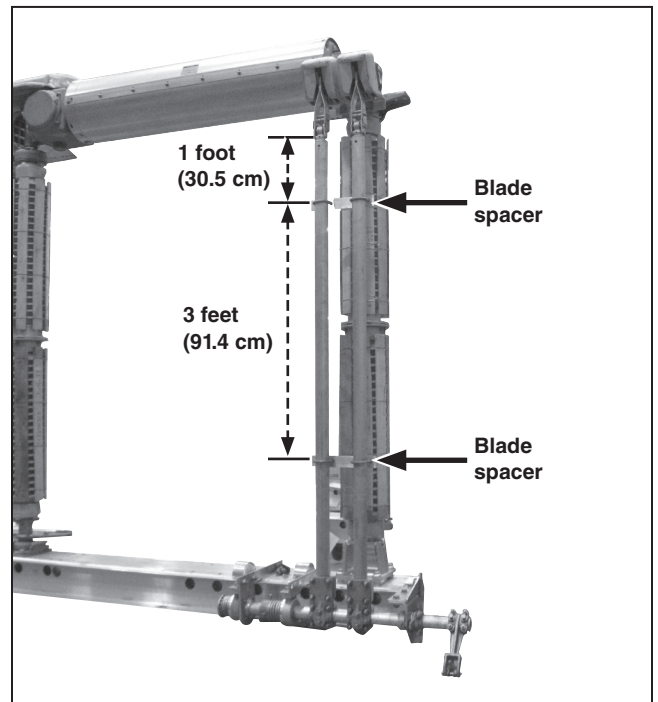

**Figure 25.** Position of blade spacers.

- STEP 9.** Inspect the blade spacers. The upper blade spacer should be approximately one foot down from the bottom of the blade. The lower blade spacer should be three feet down from the first spacer. This arrangement provides the best stability for the dual-blade assembly. See Figure 25.

If adjustment is required, loosen the ½-13 galvanized steel hex nuts and lock washers and slide the spacer up or down to the correct position. Re-tighten the hardware.

## Inspection Recommendations

---

To ensure the grounding switch's continued proper performance, it should be inspected in accordance with S&C's recommended schedule and procedures contained in S&C Instruction Sheet 711-590.