

Installation

Table of Contents

Introduction	2	Safety Precautions	4
Qualified Persons	2	Shipping and Handling	5
Read This Instruction Sheet	2	Inspection	5
Retain This Instruction Sheet	2	Packing	5
Proper Application.....	2	Storage	5
Safety Information	3	Installation	6
Understanding Safety-Alert Messages	3	Before Starting	6
Following Safety Instructions.....	3	Installing the Grounding Switch.....	6
Replacement Instructions and Labels	3	Inspection Recommendations	14



Introduction

Qualified Persons

WARNING

Only qualified persons knowledgeable in the installation, operation, and maintenance of overhead and underground electric distribution and transmission equipment, along with all associated hazards, may install, operate, and maintain the equipment covered by this publication. A qualified person is someone trained and competent in:

- The skills and techniques necessary to distinguish exposed live parts from nonlive parts of electrical equipment
- The skills and techniques necessary to determine the proper approach distances corresponding to the voltages to which the qualified person will be exposed
- The proper use of special precautionary techniques, personal protective equipment, insulated and shielding materials, and insulated tools for working on or near exposed energized parts of electrical equipment

These instructions are intended only for such qualified persons. They are not intended to be a substitute for adequate training and experience in safety procedures for this type of equipment.

Read This Instruction Sheet

NOTICE

Thoroughly and carefully read this instruction sheet and all materials included in the product's instruction handbook before installing a grounding switch on a Mark V Circuit-Switcher. Become familiar with the Safety Information on page 3 and Safety Precautions on page 4. The latest version of this publication is available online in PDF format at sandc.com/en/contact-us/product-literature/.

Retain This Instruction Sheet

This instruction sheet is a permanent part of the S&C Mark V Circuit-Switcher. Designate a location where users can easily retrieve and refer to this publication.

Proper Application

WARNING

The equipment in this publication is only intended for the installation of grounding switches on Mark V Circuit-Switchers rated 230 kV. The application must be within the ratings for the equipment. Ratings for the S&C Mark V Circuit-Switcher are listed in the ratings table in Specification Bulletin 711-31. The ratings are also on the nameplate affixed to the product.

Understanding Safety-Alert Messages

Several types of safety-alert messages may appear throughout this instruction sheet and on labels and tags attached to the product. Become familiar with these types of messages and the importance of these signal words:

⚠ DANGER
“DANGER” identifies the most serious and immediate hazards that will likely result in serious personal injury or death if instructions, including recommended precautions, are not followed.

⚠ WARNING
“WARNING” identifies hazards or unsafe practices that can result in serious personal injury or death if instructions, including recommended precautions, are not followed.

⚠ CAUTION
“CAUTION” identifies hazards or unsafe practices that can result in minor personal injury if instructions, including recommended precautions, are not followed.

NOTICE
“NOTICE” identifies important procedures or requirements that can result in product or property damage if instructions are not followed.

Following Safety Instructions

If any portion of this instruction sheet is unclear and assistance is needed, contact the nearest S&C Sales Office or S&C Authorized Distributor, or call the S&C Global Support and Monitoring Center at 1-888-762-1100. Telephone numbers are also listed on S&C’s website, sandc.com.

NOTICE	
Read this instruction sheet thoroughly and carefully before installing the grounding switch.	

Replacement Instructions and Labels

If additional copies of this instruction sheet are required, contact the nearest S&C Sales Office, S&C Authorized Distributor, S&C Headquarters, or S&C Electric Canada Ltd.

It is important any missing, damaged, or faded labels on the equipment be replaced immediately. Replacement labels are available by contacting the nearest S&C Sales Office, S&C Authorized Distributor, S&C Headquarters, or S&C Electric Canada Ltd.

⚠ DANGER



Mark V Circuit-Switchers operate at high voltage. Failure to observe the precautions below will result in serious personal injury or death.

Some of these precautions may differ from your company's operating procedures and rules. Where a discrepancy exists, follow your company's operating procedures and rules.

1. **QUALIFIED PERSONS.** Access to Mark V Circuit-Switchers must be restricted only to qualified persons. See the "Qualified Persons" section on page 2.
2. **SAFETY PROCEDURES.** Always follow safe operating procedures and rules.
3. **PERSONAL PROTECTIVE EQUIPMENT.** Always use suitable protective equipment, such as rubber gloves, rubber mats, hard hats, safety glasses, and flash clothing, in accordance with safe operating procedures and rules.
4. **SAFETY LABELS.** Do not remove or obscure any of the "DANGER," "WARNING," "CAUTION," or "NOTICE" labels.
5. **OPERATING MECHANISM AND BASE.** Mark V Circuit-Switchers contain fast-moving parts that can severely injure fingers. Do not remove or disassemble operating mechanisms or remove access panels unless directed by S&C Electric Company.
6. **ENERGIZED COMPONENTS.** Always consider all parts live until de-energized, tested, and grounded. Voltage levels can be as high as the peak line-to-ground voltage last applied to the unit. Units that have been energized or installed near energized lines should be considered live until tested and grounded.
7. **GROUNDING.** The Mark V Circuit-Switcher must be connected to a suitable earth ground at the base of the utility pole, or to a suitable building ground for testing, before energizing the switch and at all times when energized.
 - 8. **SWITCH POSITION.** Always confirm the **Open/Closed** position of each switch.
 - Switches and terminal pads may be energized from either side.
 - Switches and terminal pads may be energized with the switches in any position.
 - 9. **MAINTAINING PROPER CLEARANCE.** Always maintain proper clearance from energized components.
 - 10. **GROUNDING SWITCH.** Only operate the grounding switch when the Mark V Circuit-Switcher is in the **Open** position. The grounding switch is operated via an S&C Manual Geared Operating Handle installed near the base of the grounding switch. "Partway" opening or closing is undesirable. Once the associated circuit-switcher is in the **Open** position, operate the grounding switch until the grounding switch blades are 90 degrees perpendicular to the pole-unit bases.

Inspection

Examine the shipment for external evidence of damage as soon after receipt as possible, preferably before removal from the carrier's conveyance. Check the bill of lading to make sure all shipping skids, crates, and containers listed thereon are present.

If there is visible loss and/or damage:

1. Notify the delivering carrier immediately.
2. Ask for a carrier inspection.
3. Note condition of shipment on all copies of the delivery receipt.
4. File a claim with the carrier.

If concealed damage is discovered:

1. Notify the delivering carrier within 15 days of receipt of shipment.
2. Ask for a carrier inspection.
3. File a claim with the carrier.

Also notify S&C Electric Company in all instances of loss and/or damage.

Packing

An S&C erection drawing will be found in a water-resistant envelope attached to one of the three pole-units. The inclusion of a grounding switch is designated by the addition of a suffix to the circuit-switcher catalog number as follows:

- The inclusion of a grounding switch rated 70,000 amperes momentary is designated by the addition of the suffix "-G3" to the circuit-switcher catalog number.

If the switch is supplied with the catalog option "-A" for pre-assembly, the jaw-contact housing may be pre-installed. Handle the skid carefully. A crane is required to remove the crated switch from its conveyance.

Grounding switch components already installed on the circuit-switcher pole-units have been carefully adjusted at the factory and, under normal circumstances, readjustment should not be necessary.

When ordered with a circuit-switcher, grounding switch components may be shipped on the same skid as the pole-units or S&C Mounting Pedestals if furnished. Supplemental dimensional details for the grounding switch installation are included on the erection drawing for the applicable circuit-switcher.

Storage

If the grounding switch components must be stored before installation, keep them in a clean, dry, corrosion-free area to protect them from damage. Make sure each skid rests firmly on the ground and is reasonably level. Shoring under the skids may be necessary if the ground is uneven.

Before Starting

NOTICE

Installing Couplings with Piercing Set Screws

This equipment uses piercing set screws to couple the operating handle to the operating pipe, to secure the interphase operating-pipe sections, and to provide stability to couplings joining one or more lengths of pipe.

Before assembling a coupling joint, back the piercing set screws out of the coupling so the tips do not protrude into the body of the coupling. This ensures the coupling's clamp screws can be fully tightened.

These instructions are for field assembly (erection) and installation of manually operated S&C Grounding Switches, rated 70,000 amperes momentary, when furnished as original equipment for Mark V Circuit Switchers rated 230 kV. Supplemental dimensional details for the grounding-switch installation are included on the erection drawing for the applicable circuit-switcher.

Install the grounding switch only after the circuit-switcher and its power train have been completely installed and adjusted.

Note: If a grounding switch is to be added to an existing circuit-switcher installation, the components should be assembled in accordance with the special drawings provided.

Note: An S&C Manual Geared Operating handle is used to operate the grounding switch. A nongear handle is not available.

Installing the Grounding Switch

Proceed with the following steps:

STEP 1. For each circuit-switcher pole-unit, assemble the grounding-switch live parts as follows:

- (a) Mount the jaw-contact assembly on the side of the circuit-switcher terminal support casting (at the interrupter end) using the $\frac{5}{8}$ -11 \times 1½-inch stainless steel hex-head cap screws and lockwashers. See Figure 1 on page 7. The screws used to attach the jaw contact should be left loose enough for adjustment.

- (b) Attach the grounding-switch mounting angles to the circuit-switcher base as shown on the erection drawing and Figure 1 on page 7.
- (c) Attach four $\frac{5}{8}$ -11 \times 4½-inch threaded rods to the mounting angles; each uses two hex nuts. Tighten the nuts securely. Then, attach a third hex nut used to level the grounding-switch assembly to each of the four threaded rods, positioned so the top surface of each nut is approximately 1½ inches (41-mm) above the top surface of the mounting angles.
- (d) Install the grounding-switch assembly atop the threaded rods and leveling nuts using the lockwashers and hex nuts. Loosely tighten these uppermost hex nuts.
- (e) Slowly close the grounding-switch blade into the jaw-contact assembly until the blade contact just enters the jaw-contact fingers. The blade contacts should enter the jaw-contact fingers on-center; if adjustment is required, raise or lower the appropriate leveling nuts supporting the grounding switch assembly.

To avoid changing the effective height of the assembly, do not adjust more than three of the four leveling nuts. When on-center blade travel has been attained, securely tighten the bolts fastening the jaw contact.

- (f) Adjust the leveling nuts further so the grounding-switch blade applies a definite pressure to the jaw-contact fingers on closing (to ensure positive contact engagement) and rests against its stop when fully closed. Check for proper blade closure by pulling the blade away from its **Closed** position. See Figure 1 on page 7. With the blade fully closed and resting against the nylon stop in the jaw assembly, it should be possible to move the blade no more than ½ inch (13-mm) before meeting positive resistance. When proper blade closure has been attained, securely tighten the uppermost set of hex nuts used to attach the grounding-switch assembly to the mounting angles.

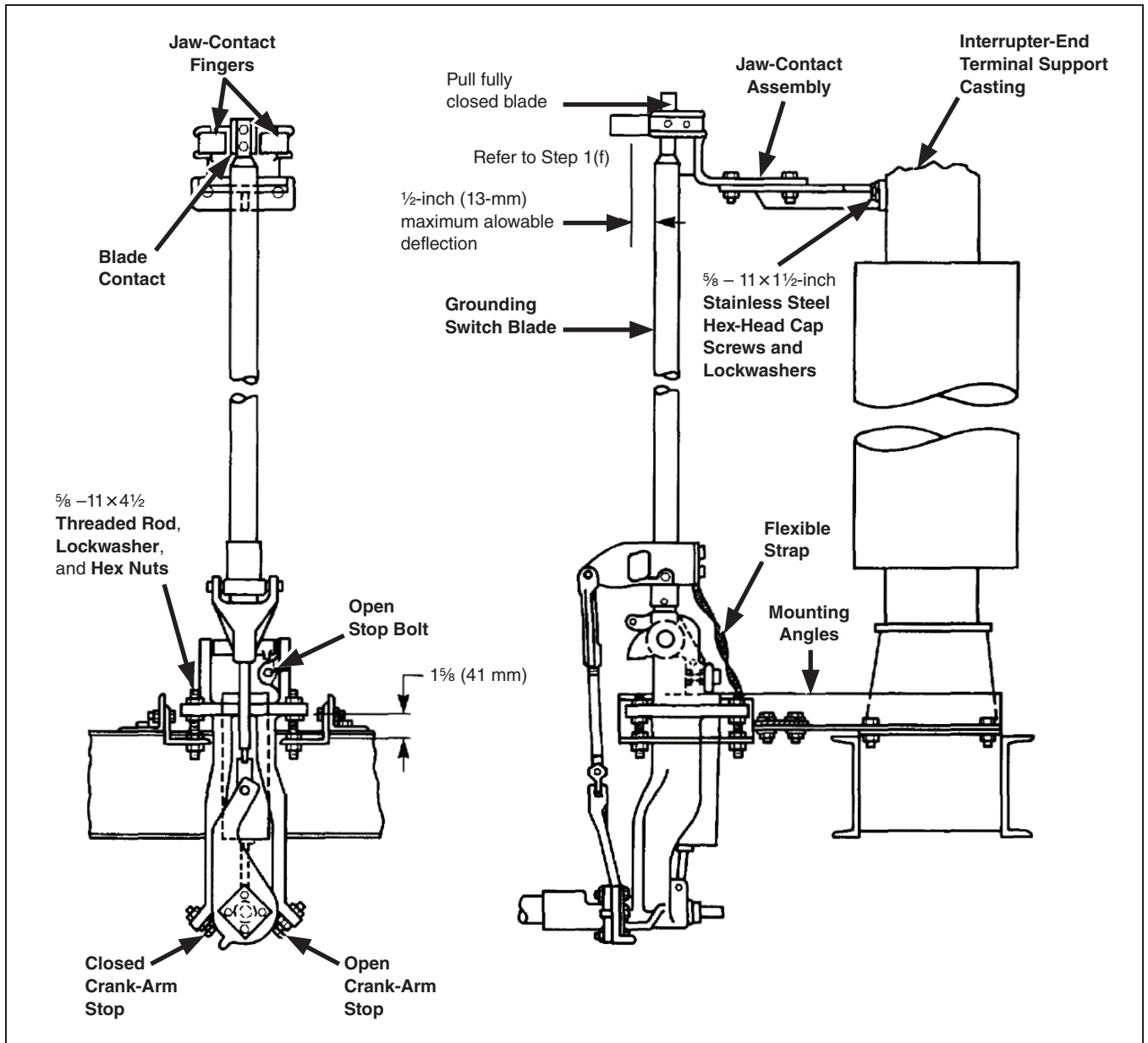

Figure 1. Grounding-switch live parts attachment detail.

Installation

- (g) Attach the flexible strap for current transfer at the hinge end of the blade assembly to the grounding switch mounting angle using the ½-inch stainless steel hardware. Then, connect the mounting angle to a suitable earth ground.●

STEP 2. Mount the outboard bearing assembly at the position shown on the erection drawing. See Figure 2 on page 9.

STEP 3. Mount the S&C Manual Geared Operating Handle in the position shown on the erection drawing.

Attach a universal coupling or a flexible coupling to the output shaft of the manual geared operating handle. Refer to the erection drawing and to Figure 3 on page 11. If a flexible coupling is used, thread the attachment bolts through the flexible coupling plate and through the coupling flange on the output shaft. Tighten the bolts to draw the flexible plate flush against the flange; this will deform the threads in the flexible plate, resulting in a binding, nonslip connection. Install and tighten the self-locking nuts. Do not use lockwashers with the attachment bolts.

STEP 4. Install the vertical operating-pipe section (or sections) and, if required, the guide bearing assembly (or assemblies) between the universal coupling at the outboard bearing assembly and the universal coupling or flexible coupling at the handle. Work from the outboard bearing assembly downward.

If more than one vertical operating-pipe section is specified, a universal coupling is used to join the upper pipe section to the next pipe section. Any additional pipe sections are joined with rigid couplings.

For each coupling, make sure the cutting tips of the piercing set screws do not protrude through the body of the coupling. Torque the clamp bolts to final tightness. Then, tighten the piercing set screws, piercing the pipe, and continue turning until a firm resistance is felt.

STEP 5. Fully close each grounding-switch blade assembly. Attach a flexible coupling (or couplings) to each grounding switch operating

shaft, as shown on the erection drawing. In some instances, the interphase drive lever is attached directly to one of the grounding switch operating shafts. In this instance, the flexible coupling should be attached to the interphase drive lever.

Thread the attachment bolts through the flexible coupling plate and through the coupling flange on the shaft. Tighten the bolts to draw the flexible plate flush against the flange. This will deform the threads in the flexible plate, resulting in a binding, nonslip connection. Install and tighten the self-locking nuts. Do not use lockwashers with the attachment bolts.

STEP 6. Install the interphase operating-pipe sections in the flexible couplings. All pipe is precut to the correct length. For each coupling, make sure the cutting tips of the piercing set screws do not protrude through the body of the coupling. Tighten the clamp bolts but do not tighten the piercing set screws at this time. Note, in some instances, the interphase drive lever is attached to the interphase operating pipe via flanged pipe connections. In this instance, first make up this connection, then install the interphase operating pipe in the flexible couplings.

If more than one pipe section is required for each phase-to-phase span, connect the sections with rigid pipe-to-pipe type couplings.

STEP 7. Install the interphase drive link between the adjustable clevis assembly (or assemblies) at the outboard bearing assembly and the interphase drive lever. Make sure the cutting tips of the piercing set screws do not protrude through the body of the clevis assembly coupling.

Tighten the U-bolts equally so they pull down evenly. Tighten the piercing set screws, piercing the pipe, and continue until a firm resistance is felt.

STEP 8. Using the manual geared operating handle, crank the grounding switch to the fully **Open** position and then to the fully **Closed** position to check three-pole group operation. If it is necessary to adjust one or two poles for more or less travel in the closing direction to attain simultaneity, it can be accomplished by loosening the clamp bolts tightened in Step 6.

● These grounding recommendations may differ from the standard operating and safety procedures of sure electric utility companies. Where a discrepancy exists, the operating procedures of the electric utility apply.

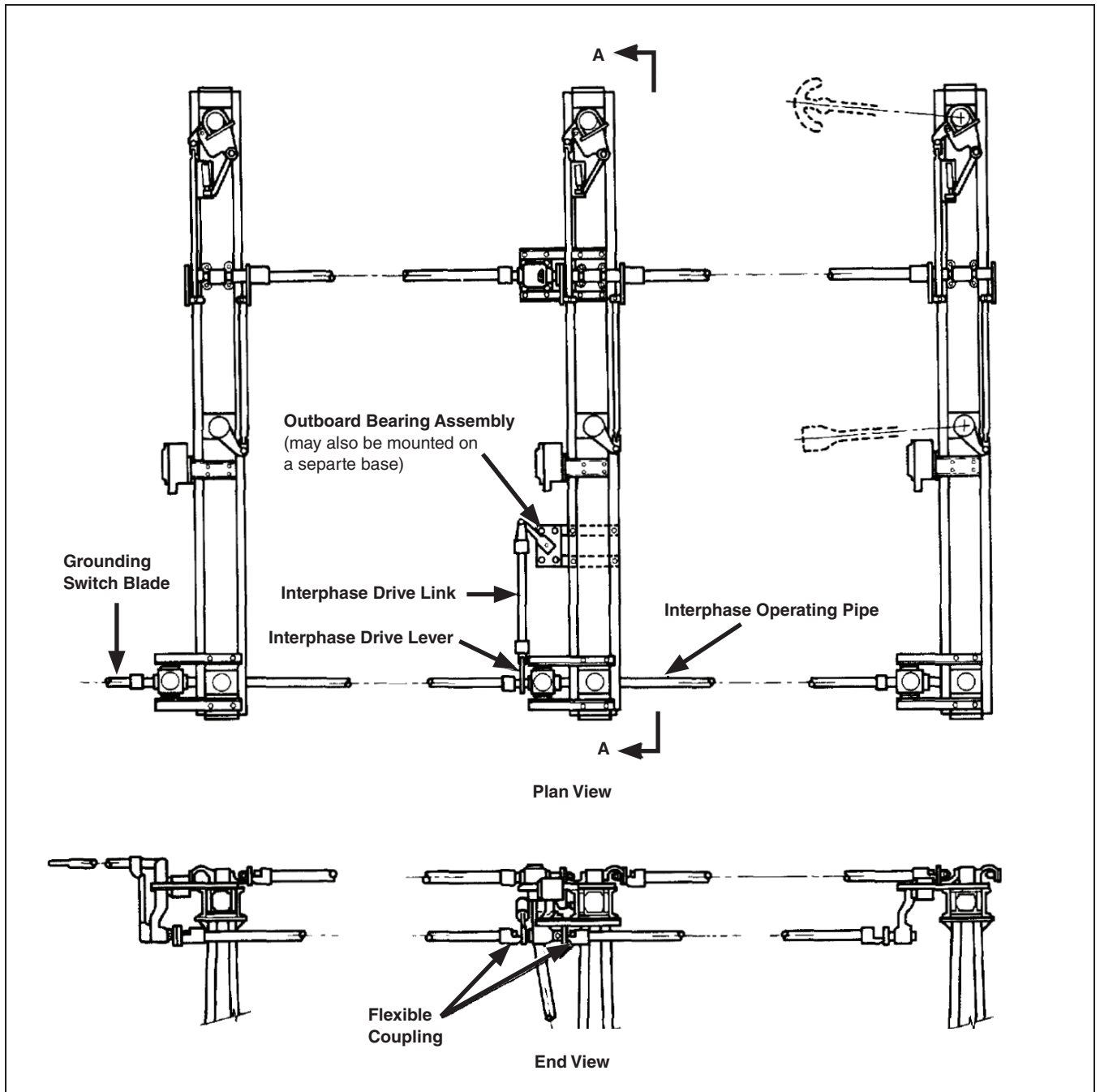

Figure 2. Typical three-pole grounding-switch configuration.

Installation

Use the geared operating handle to move the power train in the appropriate direction. Then, re-tighten the clamp bolts. Note it is usually necessary, when closing, the grounding-switch blade farthest from the outboard bearing assembly lead the grounding switch blades that are nearer to compensate for lost motion in the interphase linkage.

Do not attempt to change the Open and Closed stops for the grounding-switch assembly drive levers. These stops are factory set to provide, for all three blade assemblies, equal travel as well as the required positive-toggle condition when closed.

When three-pole group operation is satisfactory, torque to final tightness the clamp bolts on the flexible couplings at the grounding-switch assemblies. Then, tighten the piercing set screws, piercing the pipe, and continue turning until a firm resistance is felt.

STEP 9. Check the cranking-direction label located on the front of the manual geared operating handle. If the "To Open" and "To Close" cranking directions indicated are incorrect, remove the screws holding the cranking direction label. An alternate-reading label is attached behind it and should be used instead. See Figure 4 on page 12.

STEP 10. If a key interlock is not specified, omit Step 10.

The key interlock group includes a Superior Key Interlock, Type B-4003-1, with stainless steel locking bolt, zero bolt projection, and 3/4-inch bolt travel; a hinged dust cover; an interlock adapter; and an interlock collar bolted to the output shaft of the manual geared operating handle. The interlock collar is

provided with a slot to accept the key interlock bolt. If "provision only" for a key interlock is specified, the interlock will not be included. Proceed as follows:

- (a) Using the manual geared operating handle, crank the grounding switch to its fully **Open** position.
- (b) Remove the bolts fastening the interlock collar to the output shaft.
- (c) Rotate the interlock collar so the key interlock bolt, when extended, is centered in the slot in the collar. Then, replace and tighten the bolts to fasten the interlock collar in that position. Similar bolts are also used for the OPEN and CLOSED position indicators, which are to be set as described in Step 11.

STEP 11. Using the manual geared operating handle, crank the grounding switch to its fully **Open** position and set the OPEN position indicator on the output shaft of the manual geared operating handle so it is visible from the front of the handle. Then, fully close the grounding switch and set the CLOSED position indicator on the output shaft of the manual geared operating handle so the indicator is visible from the front of the handle.

STEP 12. Ground the vertical operating pipe as follows. Fasten the end of the flexible strap having the shorter ferrule to the vertical operating-pipe section, a few inches above the manual operating handle, using the connector provided. Then, connect the free end of the flexible strap to a suitable earth ground using the grounding connector at that end of the strap.●

● These grounding recommendations may differ from the standard operating and safety procedures of certain electric utility companies. Where a discrepancy exists, the operating procedures of the electric utility apply.

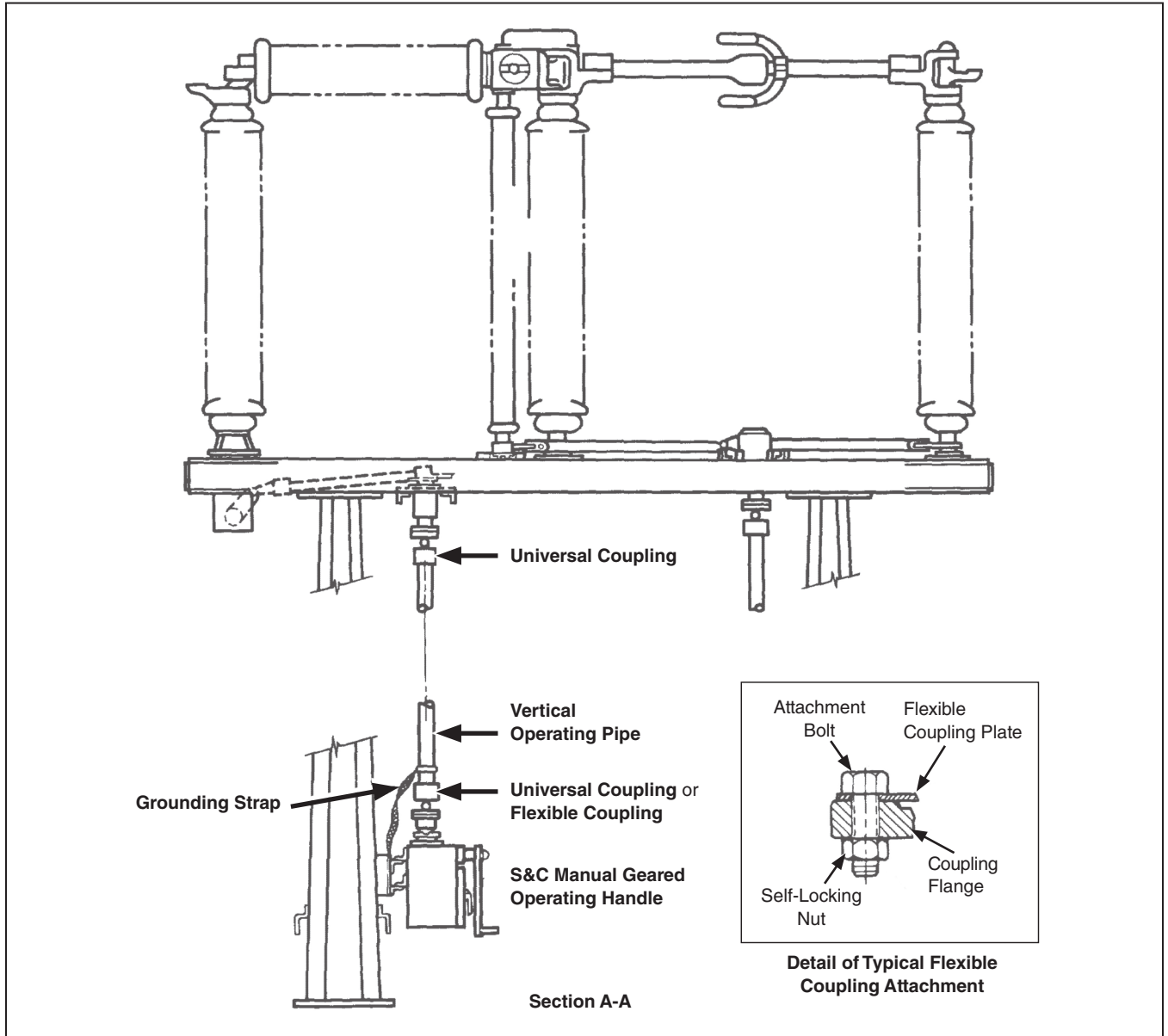

Figure 3. Detail view of installation of S&C Manual Geared Operating Handle.

Installation

STEP 13. If the S&C Manual Geared Operating Handle is furnished with an auxiliary switch, catalog number suffix "-Q" or "-W," the switch will be mounted inside the operating-handle enclosure, along with a terminal block for the user's connections. Each auxiliary-switch contact is operated by a cam-actuated roller.

A contact is closed if its roller is disengaged from a cam and, conversely, a contact is open if its roller is engaged by a cam. The cams are individually adjustable in 4.5-degree incre-

ments. Adjustment of the cams is accomplished as follows:

- (a) Raise (or lower) the cam toward its adjacent spring until the cam is separated from the teeth of the inner gear. See Figure 5.
- (b) Rotate the cam to advance or delay engagement with its roller.
- (c) Lower (or raise) the cam, making sure the teeth are in mesh with the inner gear.

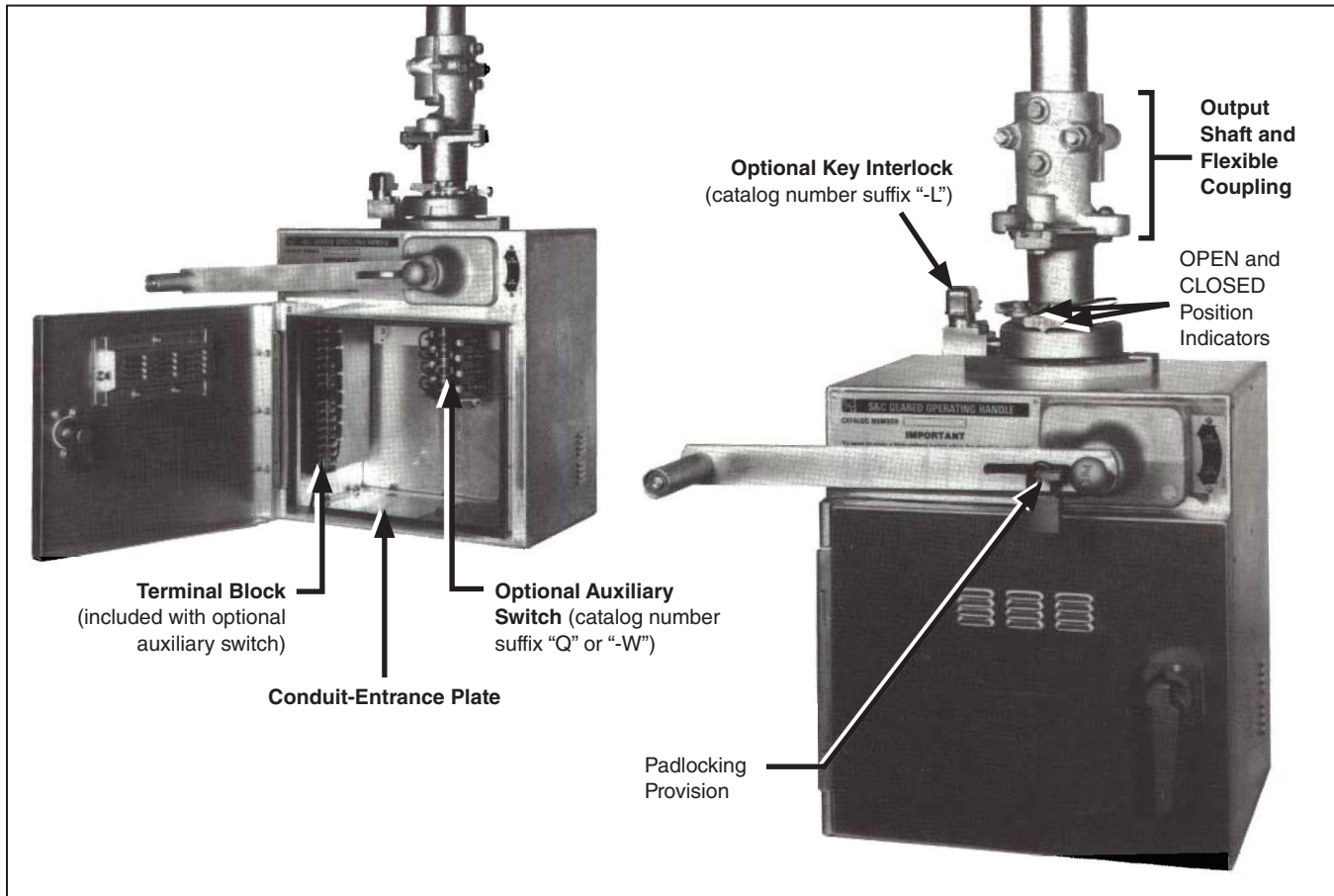

Figure 4. Manual Geared Operating Handle.

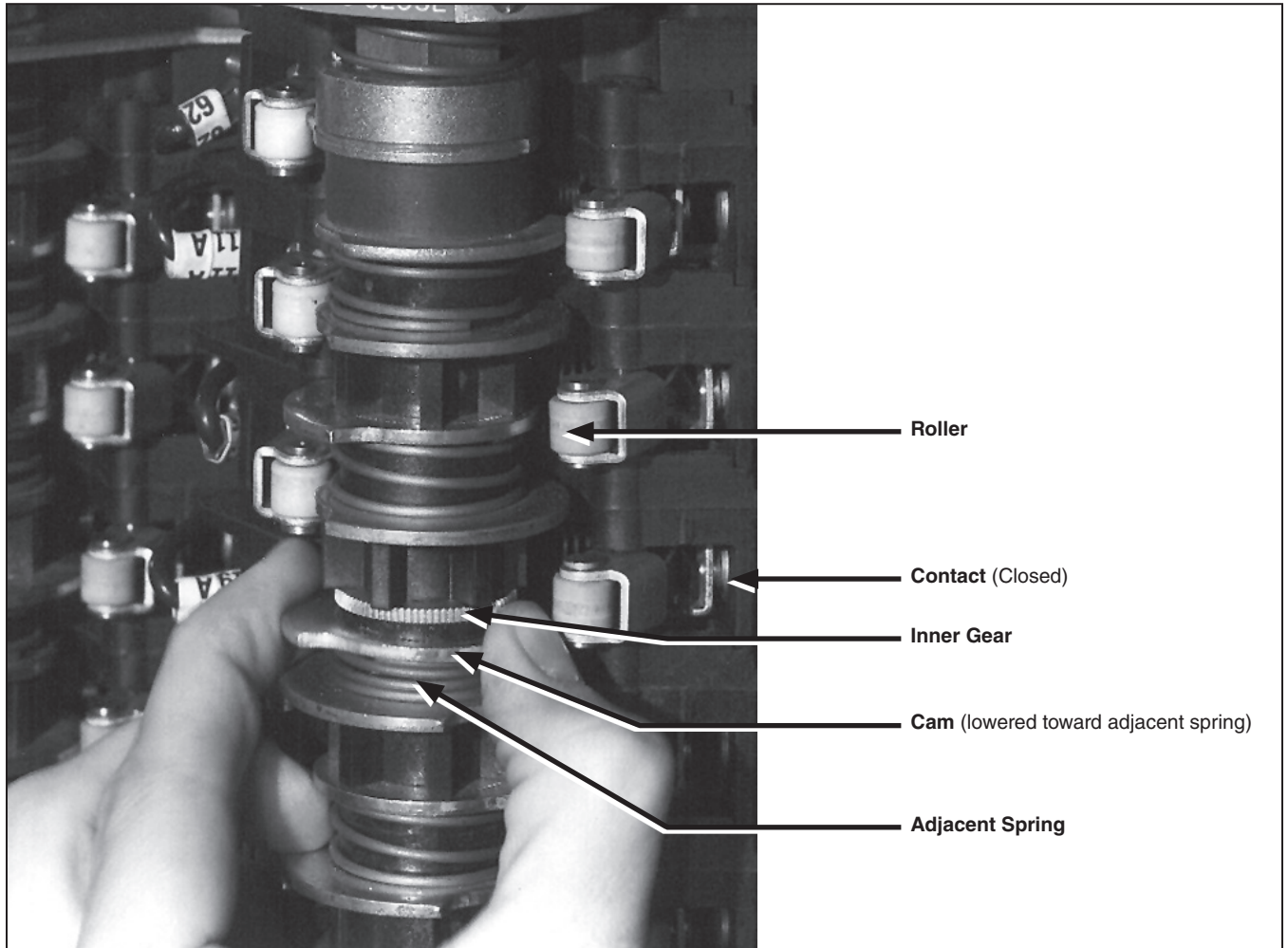

Figure 5. Adjustment of cams on auxiliary switch.

Inspection Recommendations

To ensure the grounding switch's continued proper procedures, it should be inspected in accordance with S&C's recommended schedule and procedures contained in S&C Instruction Sheet 711-590.