

Installation

Table of Contents

Introduction	2	Safety Precautions	4
Qualified Persons	2	Overview	5
Read This Instruction Sheet	2	Installation	6
Retain This Instruction Sheet	2	34.5-kV through 69-kV Vertical-Break Style and Integer-Style Circuit-Switcher Pre-Insertion Inductors	6
Proper Application.....	2	115-kV and 138-kV Vertical-Break Style Circuit- Switcher Pre-Insertion Inductors.....	11
Safety Information	3	Inspection Recommendations	14
Understanding Safety-Alert Messages	3		
Following Safety Instructions.....	3		
Replacement Instructions and Labels	3		



Introduction

Qualified Persons

WARNING

Only qualified persons knowledgeable in the installation, operation, and maintenance of overhead and underground electric distribution and transmission equipment, along with all associated hazards, may install, operate, and maintain the equipment covered by this publication. A qualified person is someone trained and competent in:

- The skills and techniques necessary to distinguish exposed live parts from nonlive parts of electrical equipment
- The skills and techniques necessary to determine the proper approach distances corresponding to the voltages to which the qualified person will be exposed
- The proper use of special precautionary techniques, personal protective equipment, insulated and shielding materials, and insulated tools for working on or near exposed energized parts of electrical equipment

These instructions are intended only for such qualified persons. They are not intended to be a substitute for adequate training and experience in safety procedures for this type of equipment.

Read This Instruction Sheet

NOTICE

Thoroughly and carefully read this instruction sheet and all materials included in the product's instruction handbook before installing or operating a Mark V Circuit-Switcher. Become familiar with the Safety Information on pages 3 and Safety Precautions on page 4. The latest version of this publication is available online in PDF format at sandc.com/en/contact-us/product-literature/.

Retain This Instruction Sheet Proper Application

This instruction sheet is a permanent part of the Mark V Circuit-Switcher. Designate a location where users can easily retrieve and refer to this publication.

WARNING

The equipment in this publication is only intended for use with Mark V Circuit-Switchers. The pre-insertion inductor must be within the ratings furnished for the equipment. Ratings for the Mark V Circuit-Switcher are listed in the ratings table in S&C Specification Bulletin 711-31. The ratings are also on the nameplate affixed to the side of the Type CS-1A Switch Operator.

Understanding Safety-Alert Messages

Several types of safety-alert messages may appear throughout this instruction sheet and on labels and tags attached to the product. Become familiar with these types of messages and the importance of these signal words:

⚠ DANGER
“DANGER” identifies the most serious and immediate hazards that will likely result in serious personal injury or death if instructions, including recommended precautions, are not followed.

⚠ WARNING
“WARNING” identifies hazards or unsafe practices that can result in serious personal injury or death if instructions, including recommended precautions, are not followed.

⚠ CAUTION
“CAUTION” identifies hazards or unsafe practices that can result in minor personal injury if instructions, including recommended precautions, are not followed.

NOTICE
“NOTICE” identifies important procedures or requirements that can result in product or property damage if instructions are not followed.

Following Safety Instructions

If any portion of this instruction sheet is unclear and assistance is needed, contact the nearest S&C Sales Office or S&C Authorized Distributor, or call the S&C Global Support and Monitoring Center at 1-888-762-1100. Telephone numbers are also listed on S&C’s website, sandc.com.

NOTICE	
Read this instruction sheet thoroughly and carefully before installing a pre-insertion inductor on a Mark V Circuit-Switcher.	

Replacement Instructions and Labels

If additional copies of this instruction sheet are required, contact the nearest S&C Sales Office, S&C Authorized Distributor, S&C Headquarters, or S&C Electric Canada Ltd.

It is important any missing, damaged, or faded labels on the equipment be replaced immediately. Replacement labels are available by contacting the nearest S&C Sales Office, S&C Authorized Distributor, S&C Headquarters, or S&C Electric Canada Ltd.

DANGER



Mark V Circuit-Switchers operate at high voltage. Failure to observe the precautions below will result in serious personal injury or death.

Some of these precautions may differ from your company's operating procedures and rules. Where a discrepancy exists, follow your company's operating procedures and rules.

1. **QUALIFIED PERSONS.** Access to Mark V Circuit-Switchers must be restricted only to qualified persons. See the "Qualified Persons" section on page 2.
2. **SAFETY PROCEDURES.** Always follow safe operating procedures and rules.
3. **PERSONAL PROTECTIVE EQUIPMENT.** Always use suitable protective equipment, such as rubber gloves, rubber mats, hard hats, safety glasses, and flash clothing, in accordance with safe operating procedures and rules.
4. **SAFETY LABELS.** Do not remove or obscure any of the "DANGER," "WARNING," "CAUTION," or "NOTICE" labels.
5. **OPERATING MECHANISM AND BASE.** Mark V Circuit-Switchers contain fast-moving parts that can severely injure fingers. Do not remove or disassemble operating mechanisms or remove access panels unless directed by S&C Electric Company.
6. **ENERGIZED COMPONENTS.** Always consider all parts live until de-energized, tested, and grounded. Voltage levels can be as high as the peak line-to-ground voltage last applied to the unit. Units that have been energized or installed near energized lines should be considered live until tested and grounded.
7. **GROUNDING.** The Mark V Circuit-Switcher must be connected to a suitable earth ground at the base of the utility pole, or to a suitable building ground for testing, before energizing the switch and at all times when energized.
The ground wire(s) must be bonded to the system neutral, if present. If the system neutral is not present, proper precautions must be taken to ensure the local earth ground, or building ground, cannot be severed or removed.
8. **SWITCH POSITION.** Always confirm the **Open/Close** position of each switch.
 - Switches and terminal pads may be energized from either side.
 - Switches and terminal pads may be energized with the switches in any position.
9. **MAINTAINING PROPER CLEARANCE.** Always maintain proper clearance from energized components.

These instructions are for field assembly and installation of enhanced-duty pre-insertion inductors when furnished as original equipment with S&C Mark V Circuit-Switchers of the following styles and voltage ratings:

- Integer-style rated 34.5 kV through 69 kV
- Vertical-break style rated 34.5 kV through 138 kV

In single-bank and multiple-bank (back-to-back) capacitor switching applications, pre-insertion inductors limit inrush current, overvoltage, and audible noise at the capacitor bank bus. Pre-insertion inductors also limit switching-surge overvoltages at remote transformers. Inclusion of enhanced-duty pre-insertion inductors is designated by the addition of the suffix “-P6” or “-P61” to the circuit-switcher catalog number.

Circuit-switchers equipped with pre-insertion inductors are capable of two consecutive closing operations 5 minutes apart, followed by one closing operation every hour.

Note: For standard-duty pre-insertion inductors, refer to Instruction Sheet 711-611.

Note: When pre-insertion inductors are to be retrofitted to a circuit-switcher not originally furnished with this accessory, or to a circuit-switcher originally furnished either with earlier-production pre-insertion inductors or with now-discontinued S&C Pre-Insertion Resistors, refer to Instruction Sheet 711-613.

34.5-kV through 69-kV Vertical-Break Style and Integer-Style Circuit-Switcher Pre-Insertion Inductors

Install pre-insertion inductors only after the circuit-switcher has been completely assembled and adjusted. Prior to assembly of component parts, thoroughly wire-brush aluminum mating surfaces. Immediately coat these surfaces with Penetrox® A (available from Burndy Corporation).

Repeat the following steps for each pole-unit:

- STEP 1.** Loosely attach the inductor mounting bar to the top of the jaw-contact terminal pad using four $\frac{1}{2}$ -13 \times 2 $\frac{1}{4}$ -inch hex-head stainless steel cap screws, eight hardened flat washers, and four $\frac{1}{2}$ -13-inch hex nuts furnished. See top and side views in Figure 1 on page 7.
- STEP 2.** Loosely attach the inductor mounting brackets and spacers to each side of the terminal adapter on the front insulator stack, using four $\frac{5}{8}$ -11 \times 1 $\frac{3}{4}$ -inch hex-head stainless steel cap screws and four $\frac{5}{8}$ -inch hardened flat washers. See front and side view in Figure 1 on page 7.

For 34.5-kV through 69-kV Circuit-Switchers furnished with inductor suffix “-P5”: Remove and discard the two $\frac{1}{2}$ -13 \times 1 $\frac{1}{2}$ -inch hex-head stainless steel cap screws and two $\frac{1}{2}$ -inch hardened flat washers securing the top inductor end cap to the inductor assembly. Attach the inductor lifting bracket to the top end cap using two $\frac{1}{2}$ -13 \times 1 $\frac{1}{4}$ -inch hex-head stainless steel cap screws and two hardened flat washers. Securely tighten the hardware. See top, front, and side views in Figure 1 on page 7. Proceed to Step 4.

For 69-kV Circuit-Switchers furnished with inductor suffix “-P51”: Attach the inductor lifting bracket to the top end cap of the inductor assembly using two $\frac{1}{2}$ -13 \times 1 $\frac{1}{4}$ -inch hex-head stainless steel cap screws and two hardened flat washers. Securely tighten the hardware. See front and side view in Figure 1 on page 7.

- STEP 3.** Lift the inductor assembly on top of the inductor mounting bar and inductor mounting brackets. Attach the bottom end cap of the inductor assembly to the inductor mounting bar and inductor mounting brackets.

Attach the bottom end cap of the inductor assembly to the inductor mounting bar and inductor mounting brackets using four $\frac{1}{2}$ -13 \times 2 $\frac{1}{4}$ -inch hex-head stainless steel cap screws and four $\frac{1}{2}$ -inch hardened flat washers. Securely tighten the hardware. See front and side view in Figure 1 on page 7.

- STEP 4.** Securely tighten the four $\frac{1}{2}$ -13 \times 2 $\frac{1}{4}$ -inch hex-head stainless steel cap screws attaching the inductor mounting bar to the top of the jaw-contact terminal pad. See side and top views in Figure 1 on page 7.
- STEP 5.** Securely tighten the four $\frac{5}{8}$ -11 \times 1 $\frac{3}{4}$ -inch hex-head stainless steel cap screws attaching the inductor mounting brackets and spacers to each side of the terminal adapter on the front insulator stack. See front and side view in Figure 1 on page 7.
- STEP 6.** Remove the two $\frac{1}{2}$ -13 \times 1 $\frac{1}{4}$ -inch hex-head stainless steel cap screws and two hardened flat washers securing the lifting bracket to the top end of the inductor assembly.
- STEP 7.** Loosely attach the inductor jaw-contact assembly to the contact support tube using two $\frac{3}{8}$ -16 \times 3 $\frac{1}{4}$ -inch hex-head stainless steel cap screws and two serrated washers. See front and side view in Figure 1 on page 7.
- STEP 8.** Loosely attach the contact support tube to the inductor assembly top end cap using two support tube mounting clamps, four $\frac{1}{2}$ -13 \times 1 $\frac{1}{4}$ -inch hex-head stainless steel cap screws, and four $\frac{1}{2}$ -inch serrated washers. See top and side views in Figure 1 on page 7.

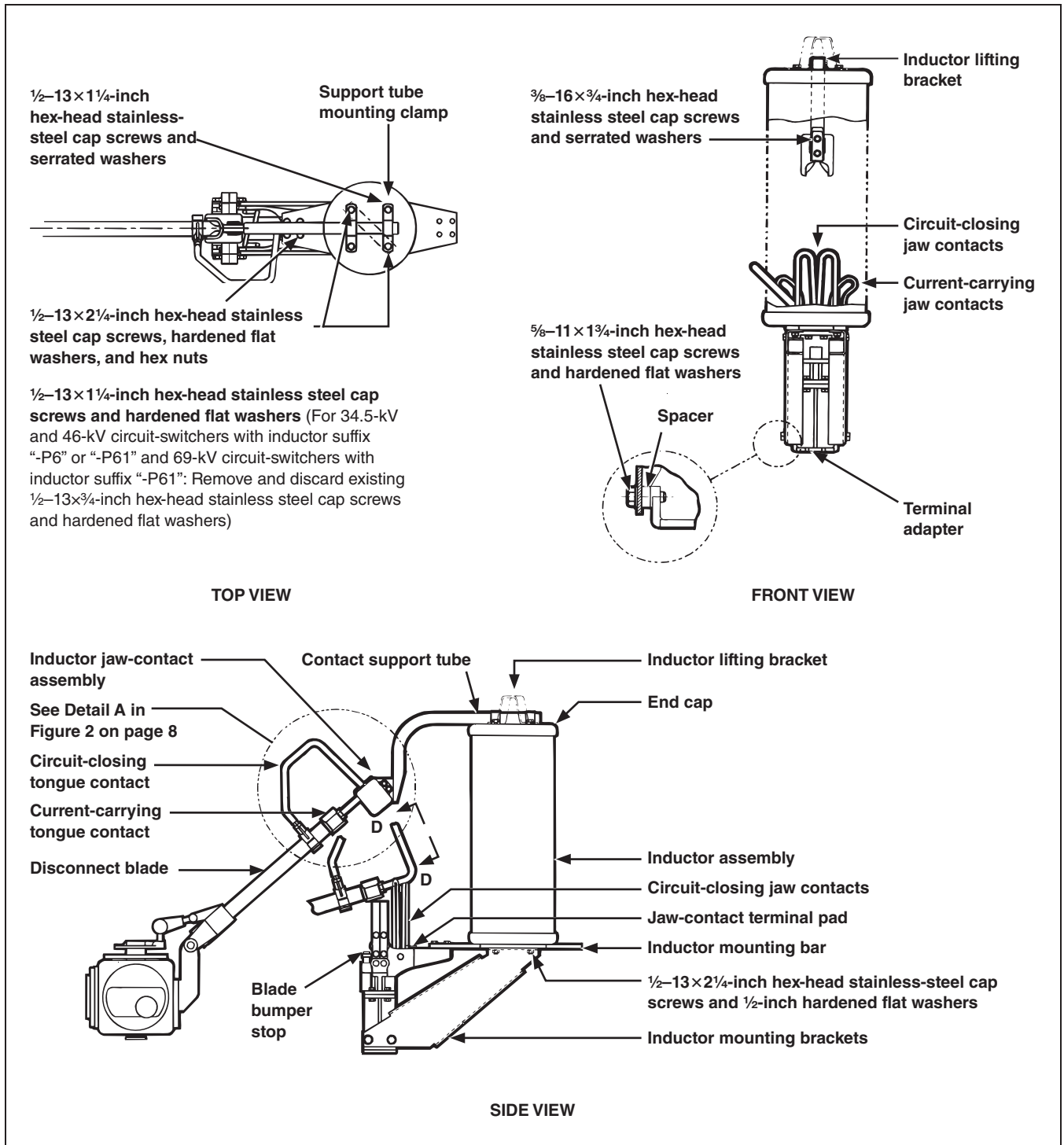

Figure 1. Top, front, and side view assembly details of standard-duty pre-insertion inductors for 34.5-kV through 69-kV vertical-break style and integer-style circuit-switchers.

Installation

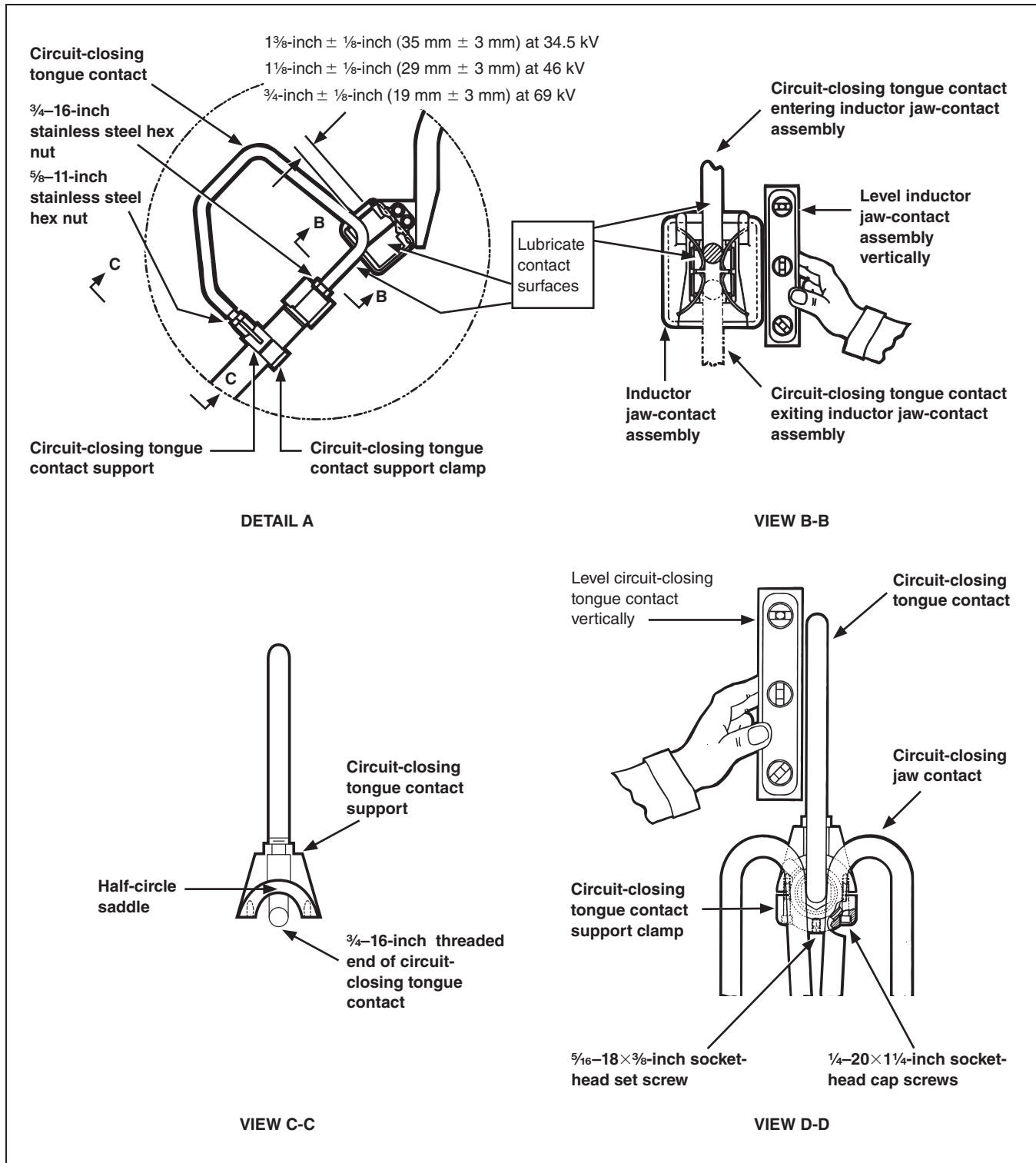

Figure 2. Detail views for assembly of standard-duty pre-insertion inductors for 34.5-kV through 69-kV vertical-break style and integer-style circuit-switchers.

STEP 9. As the circuit-switcher disconnect blade is closed, the circuit-closing tongue contact should engage each of the circuit-closing jaw-contact members with equal pressure, and the current-carrying tongue contact should enter between the current-carrying jaw-contact members with equal pressure on each side. The silver-surfaced area of the current-carrying tongue contact should center laterally with the silver-surfaced current-carrying jaw-contact members, and the blade should rotate with slight pressure against the blade bumper stop and come to rest either on the stop or slightly above it.

If adjustment of the jaw-contact assembly is necessary to obtain the described alignment, refer to the S&C Instruction Sheet 711-500 for integer-style circuit-switchers and S&C Instruction Sheet 711-510 for vertical-break style circuit-switchers.

STEP 10. Manually close the circuit-switcher so the circuit-closing tongue contact engages both contacts of the inductor jaw-contact assembly with equal pressure on each side. See View B-B in Figure 2 on page 8.

NOTICE

Make sure the circuit-switcher disconnect blades are correctly aligned with their jaw-contact assemblies.
Failure to obtain correct alignment at each pole-unit can result in damage to the circuit-switcher.

Adjust the contact support tube to attain the dimension shown in Detail A in Figure 2 on page 8. Securely tighten the four $\frac{1}{2}$ -13 \times 1 $\frac{1}{4}$ -inch hex-head stainless steel cap screws which secure the support tube mounting clamps to the inductor assembly top end cap.

STEP 11. Level the inductor jaw-contact assembly vertically while maintaining the circuit-closing tongue contact engaged between the inductor contacts with equal pressure. See View B-B in Figure 1 on page 7. Securely tighten the two $\frac{3}{8}$ -16 \times $\frac{3}{4}$ -inch hex-head stainless steel cap screws which attach the inductor jaw-contact assembly to the contact support tube. See side and front views in Figure 2 on page 8.

STEP 12. Continue closing the circuit-switcher and verify the circuit-closing tongue contact continues to engage both contacts with equal pressure as it exits the inductor contact assembly. See View B-B in Figure 2 on page 8.

If adjustment is necessary: Proceed to Step 13.

If adjustment is not necessary: Proceed to Step 14.

STEP 13. Loosen the $\frac{3}{4}$ -16-inch stainless steel hex nut which secures the circuit-closing tongue contact to the disconnect blade and loosen the two $\frac{1}{4}$ -20 \times 1 $\frac{1}{4}$ -inch socket-head cap screws and $\frac{5}{16}$ -18 \times $\frac{3}{8}$ -inch, socket-head set screw which secure the circuit-closing tongue contact support to the disconnect blade. See Detail A and View D-D in Figure 2 on page 8.

Rotate the circuit-closing tongue contact on the disconnect blade so the tongue contact engages both contacts of the inductor jaw-contact assembly with equal pressure as it exits the assembly during closing. Securely tighten the $\frac{3}{4}$ -16-inch stainless steel hex nut, the two $\frac{1}{4}$ -20 \times 1 $\frac{1}{4}$ -inch socket-head cap screws, and the $\frac{5}{16}$ -18 \times $\frac{3}{8}$ -inch, socket-head set screw.

Installation

STEP 14. Manually operate the circuit-switcher to recheck the circuit-closing tongue contact is centered on the contacts of the inductor jaw-contact assembly during closing and opening. Lubricate the contact surfaces with an appropriate lubricant, such as S&C catalog number 9999-043, furnished. See Detail A in Figure 2 on page 8.

NOTICE

Contact surfaces must be properly lubricated. Failure to lubricate these surfaces can result in excessive contact wear. Use Shell Gadus® S2 U1000 2 Lubricant catalog number 9999-043, Shell Darina SD2, Dow 33, or equivalent.

NOTICE

The circuit-closing tongue contact does not simultaneously engage the inductor jaw contact assembly and the circuit-closing jaw contact.

STEP 15. Inspect the exterior finish of the inductor winding for damage or exposure of the fiberglass roving. Use the furnished touch-up kit to refinish any damaged surfaces. Refer to Inspection Recommendations on page 14.

Note: Should the inductor winding be damaged to the extent coiled conductor is exposed, the inductor must be removed from service and replaced.

115-kV and 138-kV Vertical-Break Style Circuit-Switcher Pre-Insertion Inductors

Install pre-insertion inductors only after the circuit-switcher has been completely assembled and adjusted. Prior to assembly of component parts, thoroughly wire-brush aluminum mating surfaces. Immediately coat these surfaces with Penetrox A (available from Burndy Corporation).

Repeat the following steps for each pole-unit:

- STEP 1.** Loosely attach the inductor mounting bar to the top of the jaw-contact terminal pad, using four $\frac{1}{2}$ -13 \times $2\frac{1}{4}$ -inch hex-head stainless steel cap screws, eight hardened flat washers, and four $\frac{1}{2}$ -13-inch hex nuts furnished. See the top view and side view in Figure 3 on page 12.
- STEP 2.** Refer to front view in Figure 3 on page 12, and insert—from the underside—four $\frac{5}{8}$ -11 \times $1\frac{3}{4}$ -inch hex-head stainless steel cap screws and hardened flat washers through the tapped holes on each face of the terminal adapter. Loosely attach the inductor mounting brackets to the terminal adapter using four $\frac{5}{8}$ -inch hardened flat washers and $\frac{5}{8}$ -11-inch hex nuts furnished. See side view and front view in Figure 3 on page 12.
- STEP 3.** Attach the inductor lifting bracket to the top end cap of the inductor assembly using two $\frac{1}{2}$ -13 \times $\frac{3}{4}$ -inch hex-head stainless steel cap screws and hardened flat washers furnished. See Figure 3 on page 12. Securely tighten the hardware.
- STEP 4.** Lift the inductor assembly on top of the inductor mounting bar and the inductor mounting bracket. Attach the bottom end cap of the inductor assembly to the inductor mounting bar and inductor mounting bracket using four $\frac{1}{2}$ -13 \times $2\frac{1}{4}$ -inch hex-head stainless steel cap screws and hardened flat washers. See side view in Figure 3 on page 12. Securely tighten the hardware.
- STEP 5.** Securely tighten the $\frac{1}{2}$ -13 \times $2\frac{1}{4}$ -inch hex-head stainless steel cap screws which attach the inductor mounting bar to the top of the jaw-contact terminal pad.
- STEP 6.** Securely tighten each $\frac{5}{8}$ -11-inch hex nut attaching the inductor mounting bracket to the terminal adapter, while holding the associated $\frac{1}{2}$ -13 \times $\frac{3}{4}$ -inch hex-head stainless steel cap screw to prevent it from turning. See Figure 3 on page 12, front view. Now tighten each $\frac{5}{8}$ -11-inch hex nut $\frac{1}{8}$ additional turn.
- STEP 7.** Remove and retain the hardware securing the inductor lifting bracket to the top end cap of the inductor assembly and remove the lifting bracket.
- STEP 8.** Remove and retain the appropriate $\frac{1}{2}$ -13 \times $\frac{3}{4}$ -inch hex-head stainless steel cap screw and hardened flat washer from the top end cap of the inductor assembly. See top view in Figure 3 on page 12.
- Loosely attach the stationary arcing-rod assembly to the top end cap using two $\frac{1}{2}$ -13 \times $1\frac{3}{4}$ -inch hex-head stainless steel cap screws and hardened flat washers furnished. Insert a $\frac{1}{2}$ -13 \times $\frac{3}{4}$ -inch hex-head stainless steel cap screw and hardened flat washer into each of the other three tapped holes in the top end cap; securely tighten each of these screws.
- STEP 9.** As the circuit-switcher disconnect blade is closed, the circuit-closing tongue contact should engage each of the circuit-closing jaw-contact members with equal pressure, and the current-carrying tongue contact should enter between the current-carrying jaw-contact members with equal pressure on each side.
- The silver-surfaced area of the current-carrying tongue contact should center laterally with the silver-surfaced current-carrying jaw-contact members, and the blade should rotate with slight pressure against the blade bumper stop and come to rest either on the stop or slightly above it.

NOTICE

Make sure the circuit-switcher disconnect blades are correctly aligned with their jaw-contact assemblies. Failure to obtain correct alignment at each pole-unit can result in damage to the circuit-switcher.

Installation

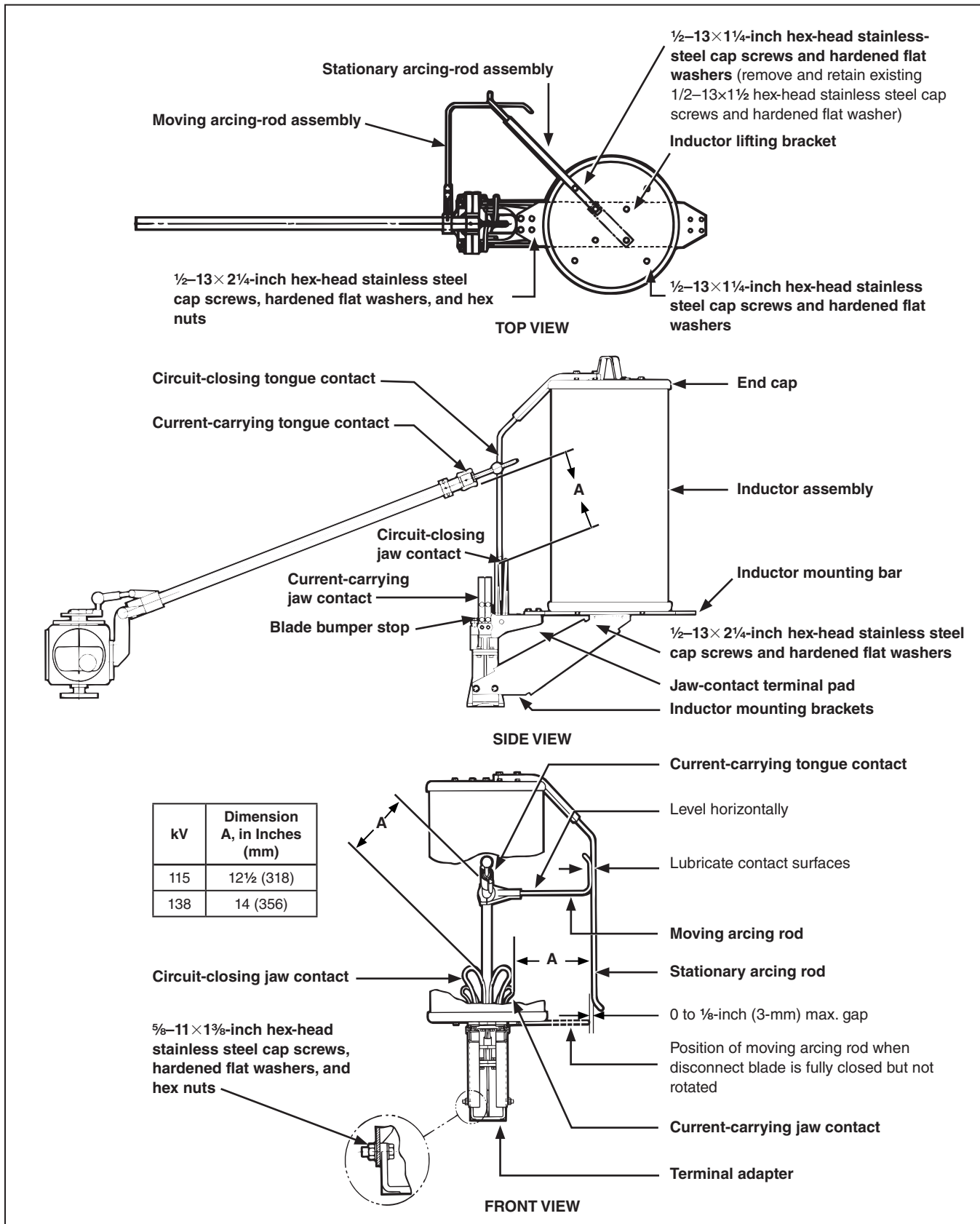

Figure 3. Assembly details of enhanced-duty pre-insertion inductors for 115-kV and 138-kV vertical-break style circuit-switchers.

If adjustment of the jaw-contact assembly is necessary to obtain the described alignment, refer to the adjustment instructions in S&C Instruction Sheet 711-510.

- STEP 10.** Manually close the circuit-switcher so the minimum metal-to-metal clearance between the current-carrying tongue contact and the nearest circuit-closing jaw contact is equal to Dimension A, as shown in side view and front view in Figure 3 on page 12.

Adjust the stationary arcing-rod assembly to obtain a 0-inch to $\frac{1}{8}$ -inch (3-mm) gap between the stationary arcing rod and the moving arcing rod. See front view in Figure 3 on page 12.

Securely tighten the two $\frac{1}{2}$ -13 \times 1 $\frac{3}{4}$ -inch hex-head stainless steel cap screws. Lubricate the contact surfaces with an appropriate lubricant, such as S&C catalog number 9999-043 or equivalent. See front view in Figure 3 on page 12.

NOTICE

Contact surfaces must be properly lubricated. Failure to lubricate these surfaces can result in excessive contact wear. Use Shell Gadus® S2 U1000 2 Lubricant catalog number 9999-043, Shell Darina SD2, Dow 33, or equivalent.

- STEP 11.** Manually operate the circuit-switcher to recheck the alignment between the moving and stationary arcing rods. During closing, the clearance between the moving and stationary arcing rods should be 0 inch to $\frac{1}{8}$ inch (3 mm), as shown in front view in Figure 3 on page 12. Readjust the stationary arcing-rod assembly, if necessary, and then securely retighten the cap screws on the inductor assembly end cap.

- STEP 12.** Verify the minimum metal-to-metal clearance between the stationary arcing rod and the nearest current-carrying jaw contact is equal to Dimension A, as shown in front view in Figure 3 on page 12.

If necessary, loosen the four $\frac{1}{2}$ -13 \times 2 $\frac{1}{2}$ -inch hex-head stainless steel cap screws which secure the inductor assembly to the inductor mounting bar and inductor mounting bracket and reposition the inductor assembly. Then, securely retighten the cap screws. Make sure the 0-inch to $\frac{1}{8}$ -inch (3 mm) gap between the stationary arcing rod and the moving arcing rod shown in front view in Figure 3 on page 12, has been maintained.

- STEP 13.** Inspect the exterior finish of the inductor winding for damage or exposure of the fiber-glass roving. Use the furnished touch-up kit to refinish any damaged surfaces. Refer to Inspection Recommendations on page 14.

Note: Should the inductor winding be damaged to the extent coiled conductor is exposed, the inductor must be removed from service and replaced.

Inspection Recommendations

Pre-insertion inductors should be inspected according to the schedule outlined in Instruction Sheet 711-590. The following procedure is recommended for inspecting and cleaning the pre-insertion inductor:

DANGER

De-energize and ground the circuit-switcher at all six terminals before making resistance measurements. Follow all applicable safety procedures.

Failure to de-energize and ground the circuit-switcher before inspection can result in serious injury or death.

- STEP 1.** Clean the exterior finish of inductor windings using a mild soap and water solution and a soft cloth. Inspect the fiberglass roving for damage or wear. Use a mild soap and water solution and a clean cloth to clean the exterior finish of the inductor winding. While cleaning the windings, inspect for damage or exposure of the fiberglass roving. Do not power wash.
- STEP 2.** If the fiberglass roving is damaged, use the touch-up kit, S&C catalog number SA-42721, to refinish any damaged surfaces. If the coiled conductor beneath the fiberglass roving is exposed, remove the inductor from service and contact the nearest S&C Sales Office for a replacement.
- STEP 3.** Inspect the moving and stationary arcing rods to verify their proper setting. Replace the arcing rods if they show significant wear or erosion.