

# Field Adjustment

## Table of Contents

<b>Introduction</b> .....	<b>2</b>	<b>Safety Precautions</b> .....	<b>4</b>
Qualified Persons .....	2	<b>Overview</b> .....	<b>5</b>
Read This Instruction Sheet .....	2	Before Starting .....	5
Retain This Instruction Sheet .....	2	<b>Adjustment of Shunt-Trip Equipped Circuit-Switchers</b> .....	<b>6</b>
Proper Application.....	2	<b>Adjustment of Non-Shunt-Trip Equipped Circuit-Switchers</b> .....	<b>9</b>
<b>Safety Information</b> .....	<b>3</b>		
Understanding Safety-Alert Messages .....	3		
Following Safety Instructions.....	3		
Replacement Instructions and Labels .....	3		

★ The instructions are also applicable to Mark IV Circuit-Switchers. For Mark III Circuit-Switchers, contact the local S&C Sales Office.



## Introduction

---

### Qualified Persons

#### **WARNING**

Only qualified persons knowledgeable in the installation, operation, and maintenance of overhead and underground electric transmission and distribution equipment, along with all associated hazards, may install, operate, and maintain the equipment covered by this publication. A qualified person is someone trained and competent in:

- The skills and techniques necessary to distinguish exposed live parts from nonlive parts of electrical equipment
- The skills and techniques necessary to determine the proper approach distances corresponding to the voltages to which the qualified person will be exposed
- The proper use of special precautionary techniques, personal protective equipment, insulated and shielding materials, and insulated tools for working on or near exposed energized parts of electrical equipment

These instructions are intended only for such qualified persons. They are not intended to be a substitute for adequate training and experience in safety procedures for this type of equipment.

### Read This Instruction Sheet

#### **NOTICE**

Thoroughly and carefully read this instruction sheet and all materials included in the product's instruction handbook before installing or operating the Mark V Circuit-Switcher. Become familiar with the Safety Information on page 3 and Safety Precautions on page 4. The latest version of this publication is available online in PDF format at [sandc.com/en/contact-us/product-literature/](http://sandc.com/en/contact-us/product-literature/).

### Retain This Instruction Sheet

This instruction sheet is a permanent part of the Mark V Circuit-Switcher. Designate a location where users can easily retrieve and refer to this publication.

### Proper Application

#### **WARNING**

The equipment in this publication is only intended for 69 kV single-gap Mark IV or Mark V Circuit-Switchers in ungrounded capacitor switching applications. Ratings for the Mark V Circuit-Switcher are listed in the ratings table in Specification Bulletin 711-31. The ratings are also on the nameplate affixed to the product.

**Understanding Safety-Alert Messages**

Several types of safety-alert messages may appear throughout this instruction sheet and on labels and tags attached to the product. Become familiar with these types of messages and the importance of these signal words:

<b>⚠ DANGER</b>
“DANGER” identifies the most serious and immediate hazards that will likely result in serious personal injury or death if instructions, including recommended precautions, are not followed.

<b>⚠ WARNING</b>
“WARNING” identifies hazards or unsafe practices that can result in serious personal injury or death if instructions, including recommended precautions, are not followed.

<b>⚠ CAUTION</b>
“CAUTION” identifies hazards or unsafe practices that can result in minor personal injury if instructions, including recommended precautions, are not followed.

<b>NOTICE</b>
“NOTICE” identifies important procedures or requirements that can result in product or property damage if instructions are not followed.

**Following Safety Instructions**

If any portion of this instruction sheet is unclear and assistance is needed, contact the nearest S&C Sales Office or S&C Authorized Distributor, or call the S&C Global Support and Monitoring Center at 1-888-762-1100. Telephone numbers are also listed on S&C’s website, [sandc.com](http://sandc.com).

<b>NOTICE</b>	
Read this instruction sheet thoroughly and carefully before adjusting the Mark V Circuit-Switcher.	

**Replacement Instructions and Labels**

If additional copies of this instruction sheet are required, contact the nearest S&C Sales Office, S&C Authorized Distributor, S&C Headquarters, or S&C Electric Canada Ltd.

It is important any missing, damaged, or faded labels on the equipment be replaced immediately. Replacement labels are available by contacting the nearest S&C Sales Office, S&C Authorized Distributor, S&C Headquarters, or S&C Electric Canada Ltd.

### DANGER



**Mark V Circuit-Switchers operate at high voltage. Failure to observe the precautions below will result in serious personal injury or death.**

Some of these precautions may differ from your company's operating procedures and rules. Where a discrepancy exists, follow your company's operating procedures and rules.

1. **QUALIFIED PERSONS.** Access to Mark V Circuit-Switchers must be restricted only to qualified persons. See the "Qualified Persons" section on page 2.
2. **SAFETY PROCEDURES.** Always follow safe operating procedures and rules.
3. **PERSONAL PROTECTIVE EQUIPMENT.** Always use suitable protective equipment, such as rubber gloves, rubber mats, hard hats, safety glasses, and flash clothing, in accordance with safe operating procedures and rules.
4. **SAFETY LABELS.** Do not remove or obscure any of the "DANGER," "WARNING," "CAUTION," or "NOTICE" labels.
5. **OPERATING MECHANISM AND BASE.** Mark V Circuit-Switchers contain fast-moving parts that can severely injure fingers. Do not remove or disassemble operating mechanisms or remove access panels unless directed by S&C Electric Company.
6. **ENERGIZED COMPONENTS.** Always consider all parts live until de-energized, tested, and grounded. Voltage levels can be as high as the peak line-to-ground voltage last applied to the unit. Units that have been energized or installed near energized lines should be considered live until tested and grounded.
7. **GROUNDING.** The Mark V Circuit-Switcher must be connected to a suitable earth ground at the base of the utility pole, or to a suitable building ground for testing, before energizing the switch and at all times when energized.  

The ground wire(s) must be bonded to the system neutral, if present. If the system neutral is not present, proper precautions must be taken to ensure the local earth ground, or building ground, cannot be severed or removed.
8. **SWITCH POSITION.** Always confirm the **Open/Close** position of each switch.
  - Switches and terminal pads may be energized from either side.
  - Switches and terminal pads may be energized with the switches in any position.
9. **MAINTAINING PROPER CLEARANCE.** Always maintain proper clearance from energized components.

## Before Starting

These instructions are for field adjustment of the pole-unit brains of 69 kV single-gap Mark V and Mark IV Circuit-Switchers in ungrounded capacitor-switching applications. Prior to March 1993, such circuit-switchers were offered for this application under the condition that the brains be inspected on a continuing basis, and adjusted as necessary to prevent the occurrence of restrikes during operation. Circuit-switchers equipped with the optional shunt-trip device should be inspected, and the brains adjusted every 500 operations.●

This procedure is not applicable to all other applications of the 69 kV single-gap Mark IV and Mark V Circuit-Switcher. Contact the local S&C Sales Office with any questions or concerns.

●After March 1993, two-gap Mark V Circuit-Switchers were offered for ungrounded capacitor-switching applications at 69 kV. Two-gap Mark V Circuit-Switchers do not require brain adjustment.

## Adjustment of Shunt-Trip Equipped Circuit-Switchers

### **⚠ DANGER**

The circuit-switcher must be de-energized, isolated from high-voltage sources, and grounded at all six terminals before performing this procedure.

**Failure to de-energize the circuit-switcher before adjusting the brain mechanism will cause serious injury or death.**

To measure and adjust opening simultaneity on shunt-trip equipped circuit-switchers, complete the following steps:

### **NOTICE**

To avoid multiple iterations of this procedure, do not adjust the the brains at more than two of the pole-units.

**STEP 1.** Follow standard utility procedures for clearing and tagging equipment on which work is to be performed. Then, close the circuit-switcher by pressing the CLOSE pushbutton on the Type CS-1A Switch Operator. ● For more information on the Type CS-1A Switch Operator, see S&C Instruction Sheet 719-501.

**STEP 2.** Using suitable user-furnished instrumentation, such as a digital or direct-writing oscillograph, measure the degree of opening simultaneity of the interrupters when electrically tripped by means of the shunt-trip device. If the time between the last break of the first pole-unit to trip is 3 milliseconds or less, proceed to Step 10. If this measurement is greater than 3 milliseconds, continue with Step 3.

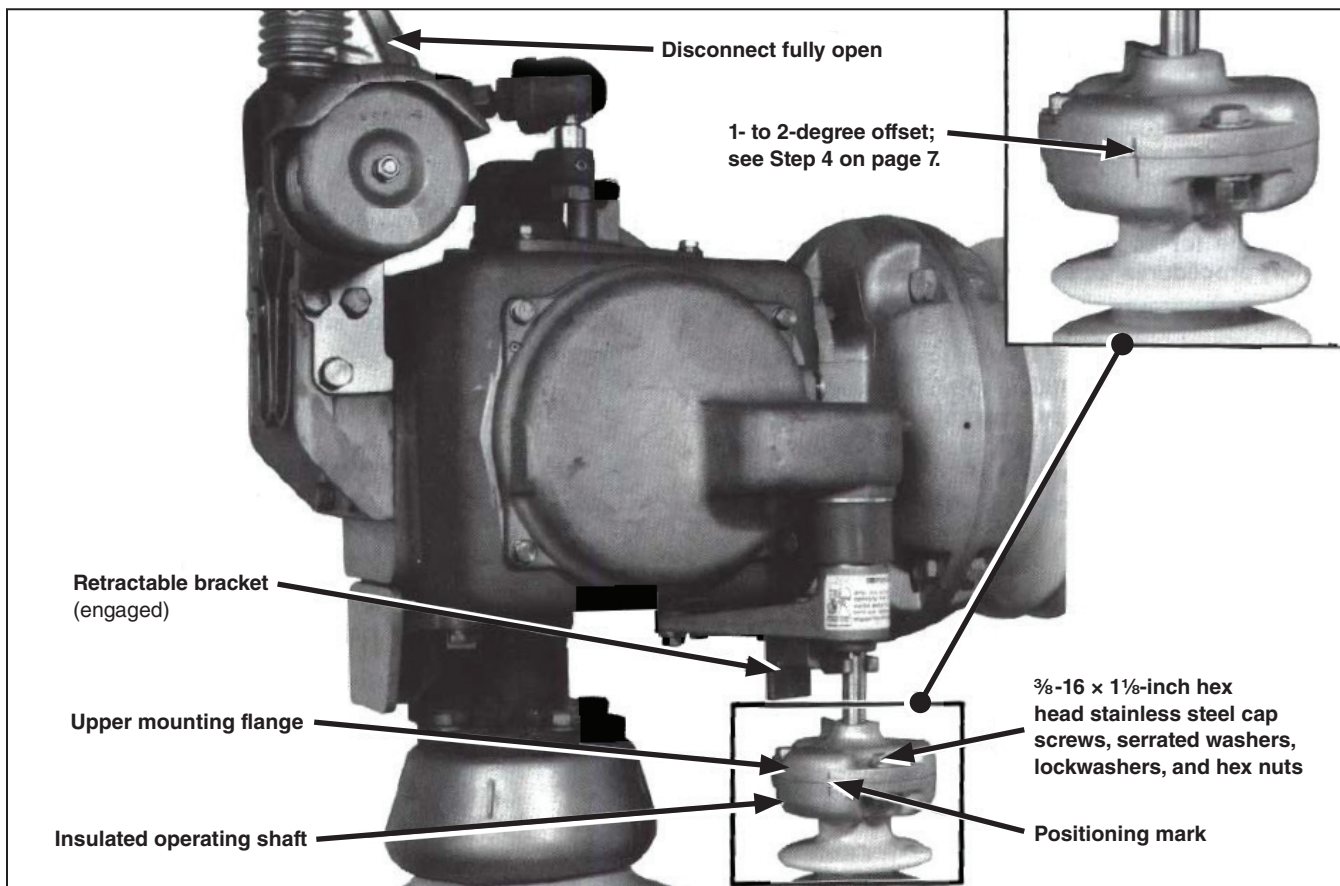

**Figure 1. Adjusting the angular position of the upper mounting flange with respect to the insulated operating shaft on a shunt-trip equipped Mark V Circuit-Switcher.**

● OPEN/CLOSE pushbuttons are not included on switch operators specified with catalog number suffix "-J." If pushbuttons are unavailable, momentarily jumper terminals 1 and 9 to close the circuit-switcher. (Terminal designations may differ if the switch operator was ordered as a "special." In such cases, refer to the wiring diagram for the correct terminal designations.)

- STEP 3.** With the circuit-switcher in the fully **Open** position, remove the fuseholder for the motor circuit and the fuseholder for the shunt-trip circuit from the Type CS-1A Switch Operator.
- STEP 4.** At the brain of the last pole-unit to trip, engage the retractable bracket as shown in Figure 1 on page 6. Draw a vertical positioning mark across the upper mounting flange and the shunt-trip insulated operating shaft, as shown. Loosen the three  $\frac{3}{8}$ -16  $\times$   $1\frac{1}{8}$ -inch hex head stainless steel cap screws which attach the upper mounting flange to the shunt-trip insulated operating shaft.

Rotate the upper mounting flange clockwise (as viewed from the top) 1 to 2 degrees with respect to the insulated operating shaft as shown in Figure 1 on page 6 (inset). Securely tighten the cap screws. This adjustment will result in an earlier tripping of the interrupter. Disengage the retractable bracket.

- STEP 5.** Replace the fuseholder for the motor circuit and the fuseholder for the shunt-trip circuit. Then, close the circuit-switcher.

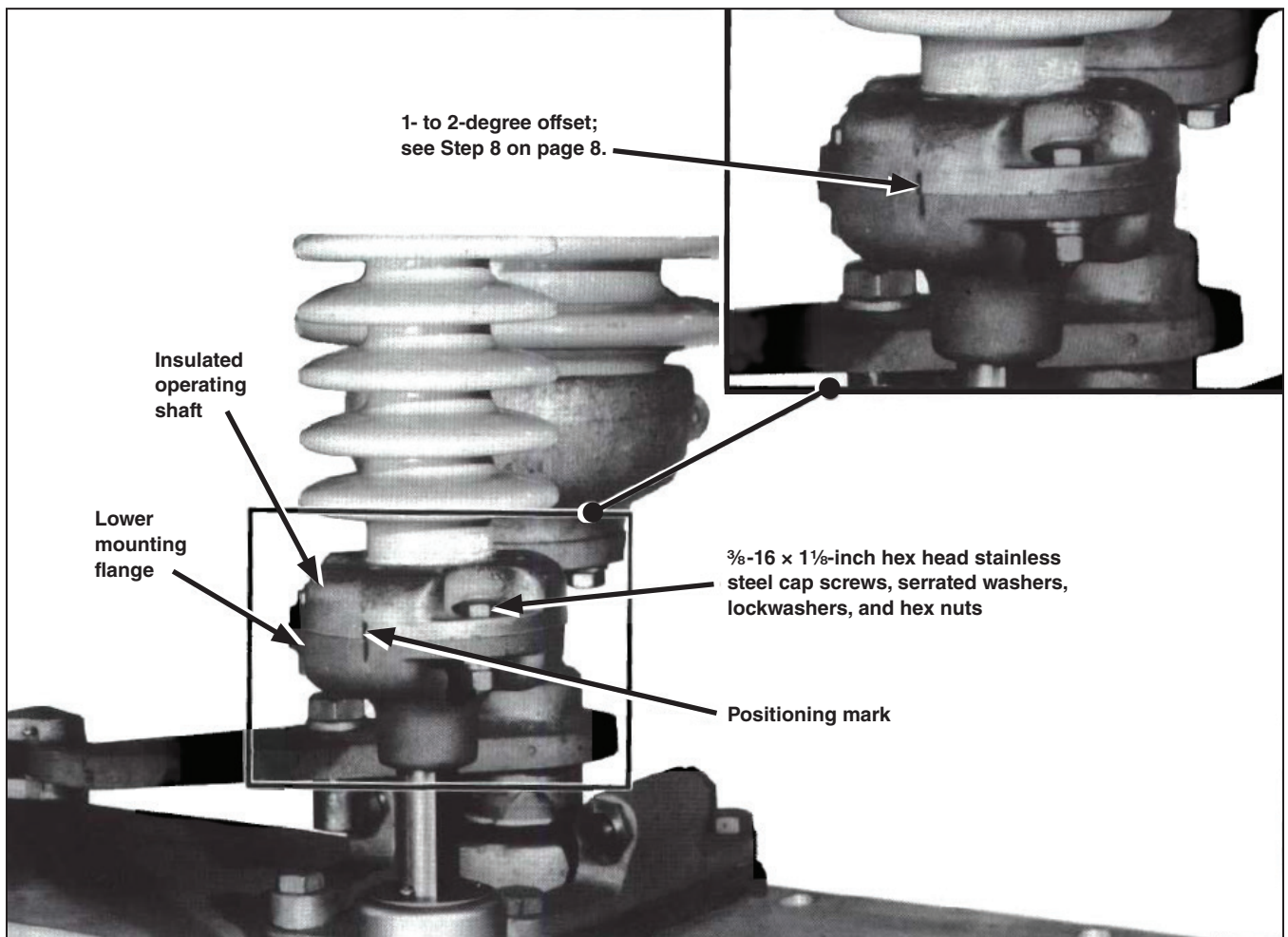

Figure 2. Adjusting the angular position of the lower mounting flange with respect to the insulated operating shaft on a shunt-trip equipped Mark V Circuit-Switcher.

## Adjustment of Shunt-Trip Equipped Circuit-Switchers

---

**STEP 6.** Again, using suitable user-furnished instrumentation, such as a digital or direct-writing oscillograph, measure the degree of opening simultaneity of the interrupters when electrically tripped by means of the shunt-trip device.

If the time between the last break of the first pole-unit to trip to the last break of the last pole-unit to trip is 3 milliseconds or less, proceed to Step 10. If this measurement is still greater than 3 milliseconds, continue with Step 7.

**STEP 7.** With the circuit-switcher in the fully **Open** position, remove the fuseholder for the motor circuit and the fuseholder for the shunt-trip circuit from the switch operator.

**STEP 8.** At the brain of the last pole-unit to trip, engage the retractable bracket as shown in Figure 1 on page 6. Draw a vertical positioning mark across the lower mounting flange and the

shunt-trip insulated operating shaft, as shown in Figure 2 on page 7. Loosen the three  $\frac{3}{8}$ -16 $\times$ 1 $\frac{1}{8}$ -inch hex head stainless steel cap screws which attach the lower mounting flange to the shunt-trip insulated operating shaft. Rotate the lower flange clockwise (as viewed from the top) 1- to 2-degrees with respect to the insulated operating shaft as shown in Figure 2 on page 7 (inset), and securely tighten the cap screws. This adjustment will result in earlier tripping of the interrupter. Disengage the retractable bracket.

**STEP 9.** Replace the fuseholder for the motor circuit and the fuseholder for the shunt-trip circuit. Then, close the circuit-switcher. Repeat Step 2 on page 6 through Step 8 until the time between the last break of the first pole-unit to trip is 3 milliseconds or less.

**STEP 10.** Disconnect the instrumentation. The circuit-switcher can now be returned to service.

## DANGER

The Mark V or Mark IV Circuit-Switcher must be de-energized, isolated from high-voltage sources, and grounded at all six terminals before performing this procedure.

**Failure to de-energize the circuit-switcher before adjusting the brain mechanism will cause serious injury or death.**

To measure and adjust opening simultaneity on Mark V or Mark IV Circuit-Switchers without the optional shunt-trip feature, complete the following steps:

## NOTICE

To avoid multiple iterations of this procedure, do not adjust the brains at more than two of the pole-units.

- STEP 1.** Follow standard utility procedures for clearing and tagging equipment on which work is to be performed. Then, close the circuit-switcher by pressing the CLOSE pushbutton on the Type CS-1A Switch Operator. ● For more information on the Type CS-1A Switch Operator, see S&C Instruction Sheet 719-501.
- STEP 2.** Using suitable user-furnished instrumentation, such as a digital or direct-writing oscillograph, measure the degree of opening simultaneity of

the interrupters when electrically tripped by the switch operator motor.

If the time between the last break of the first pole-unit to trip is 3 milliseconds or less, proceed to Step 8 on page 11. If this measurement is greater than 3 milliseconds, continue with Step 3.

- STEP 3.** With the circuit-switcher in the fully **Open** position, remove the fuseholder for the motor circuit from the Type CS-1A Switch Operator.

- STEP 4.** Use the manual operating handle on the switch operator to close the circuit-switcher. Slowly open the circuit-switcher by turning the manual operating handle, just until all three interrupters are heard to trip.

Continue to slowly open the circuit-switcher by turning the manual operating handle a few more degrees, just to the point at which the disconnect current-carrying tongue contacts disengage their respective current-carrying jaw contact. See Figure 3 on page 10.

With the disconnect in this position, remove—at the brain of the last pole-unit to trip—the four  $\frac{3}{8}$ -16  $\times$   $1\frac{1}{4}$ -inch hex-head stainless-steel cap screws from the brain cover. See Figure 4 on page 11. Use a small screwdriver or pry tool, if necessary, to pry the brain cover loose, but be careful not to damage the internal O-ring seal.

● OPEN/CLOSE pushbuttons are not included on switch operators specified with catalog number suffix “-J.” If pushbuttons are unavailable, momentarily jumper terminals 1 and 9 to close the circuit-switcher. (Terminal designations may differ if the switch operator was ordered as a “special.” In such cases, refer to the wiring diagram for the correct terminal designations.)

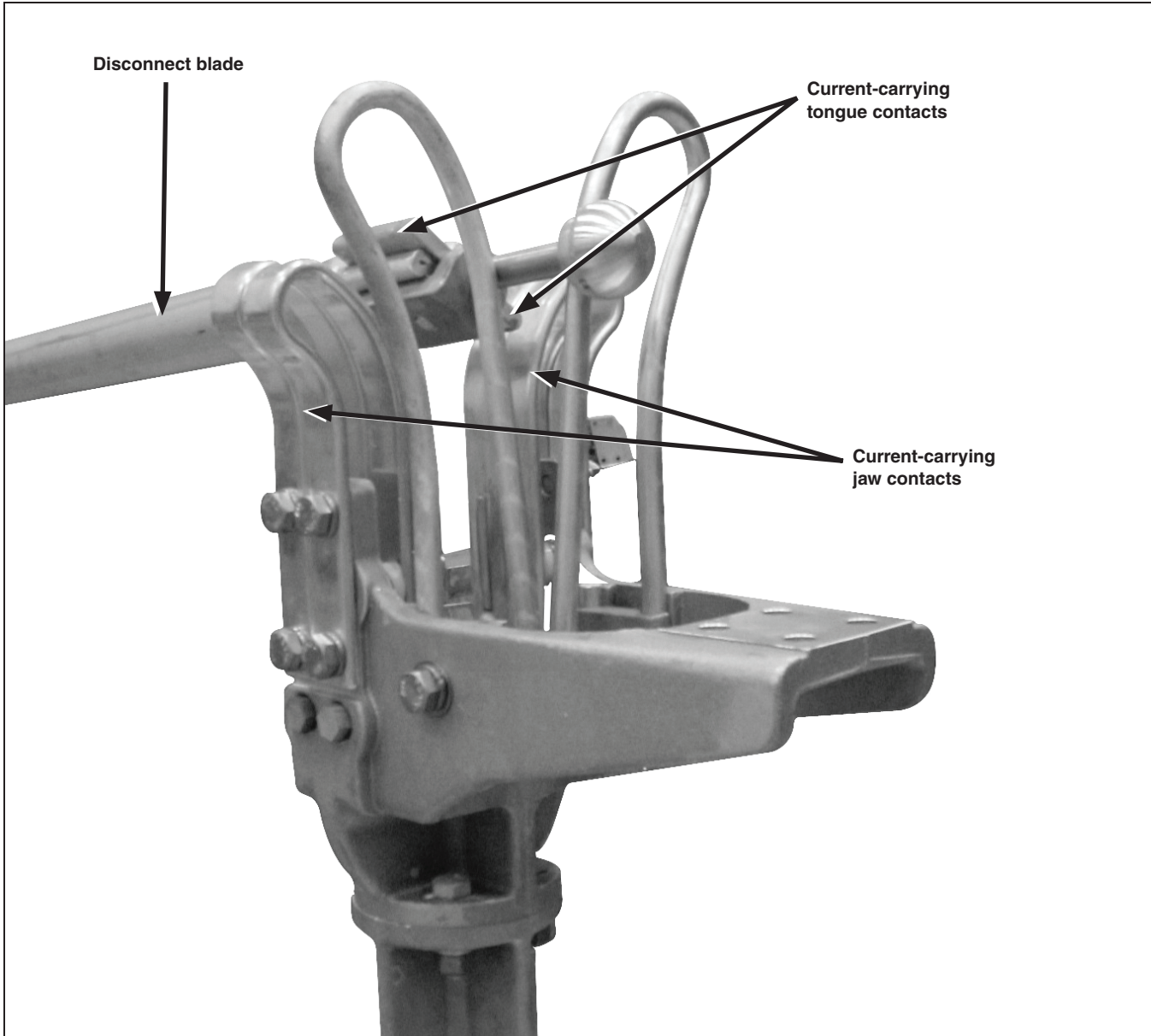

Figure 3. Position of the disconnect blade required for performing latch-gap adjustment of non-shunt-trip equipped Mark V Circuit-Switchers.

## Adjustment of Non-Shunt-Trip Equipped Circuit-Switchers

**STEP 5.** Using a 1/8-inch long-handled Allen wrench or a 3/8-inch Allen socket attached to a 3/8-inch socket wrench, turn the socket-head latch gap adjusting screw 1/2-turn clockwise. See Figure 5 on page 12. This latch-gap adjustment will result in earlier tripping of the interrupter.

### **⚠ WARNING**

DO NOT adjust the latch-gap adjusting screw on Mark V or Mark IV Circuit-Switchers with the disconnect opened further than shown in Figure 3 on page 10 since the stored-energy springs in the brain may be charged.

**Adjusting the latch-gap with the blade in any other position may result in the brain tripping, causing serious injury to the hands.**

**STEP 6.** Replace the fuseholder for the motor circuit. Then close the circuit-switcher and repeat Step 2 on page 9 through Step 5 until the time between the last break of the first pole-unit to trip is 3 milliseconds or less.

**STEP 7.** Replace the brain cover(s) using the locating pin on each brain housing (if furnished) as a positioning guide. See Figure 4. Take care not to damage the O-ring seal. Secure each brain cover using the reserved four 3/8-16 × 1 1/4-inch hex-head stainless-steel cap screws removed in Step 4 on page 9.

**STEP 8.** Disconnect the instrumentation. The circuit-switcher can now be returned to service.

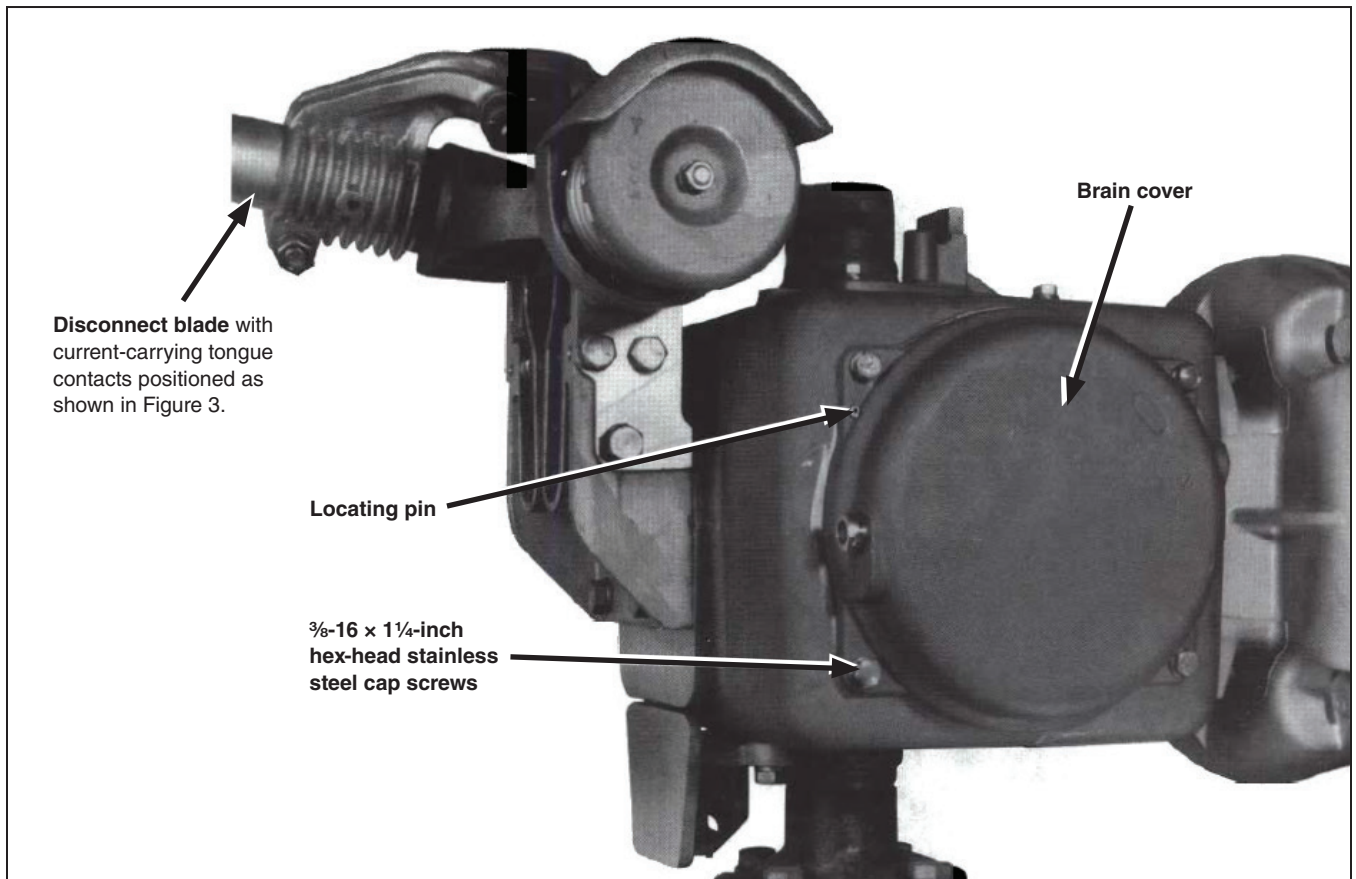

Figure 4. Removing the brain cover on non-shunt-trip equipped Mark V or Mark IV Circuit-Switchers.

## Adjustment of Non-Shunt-Trip Equipped Circuit-Switchers

### **WARNING**

DO NOT adjust the latch-gap adjusting screw on Mark V or Mark IV Circuit-Switchers with the disconnect opened further than shown in Figure 3 on page 10 because the stored-energy springs in the brain may be charged.

**Adjusting the latch-gap with the blade in any other position may result in the brain tripping, causing serious injury to the hands.**

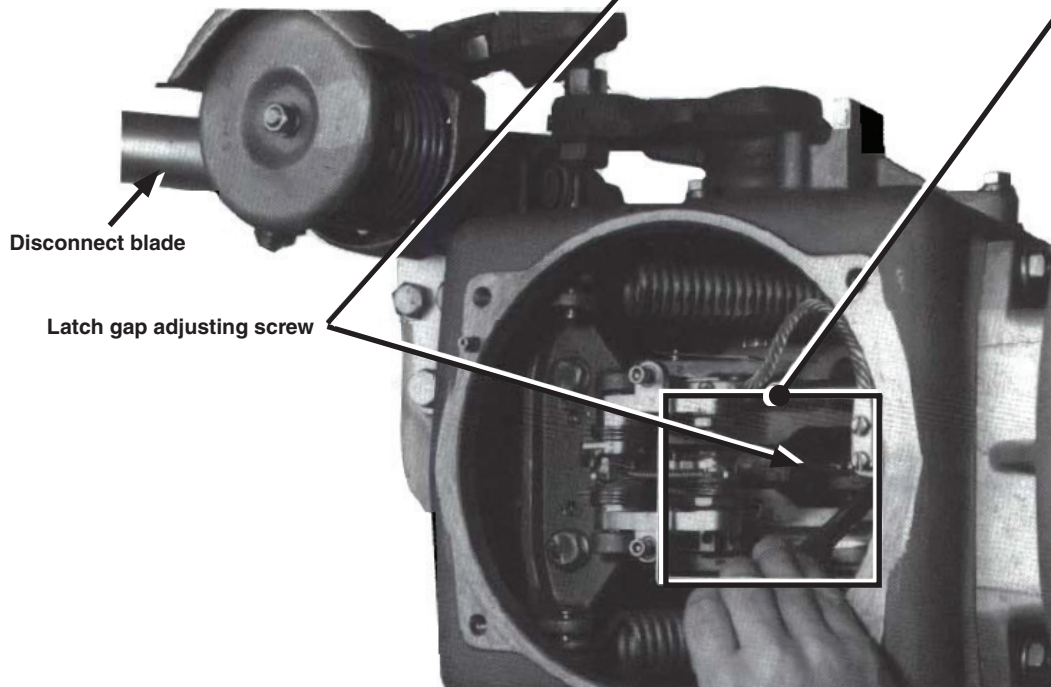
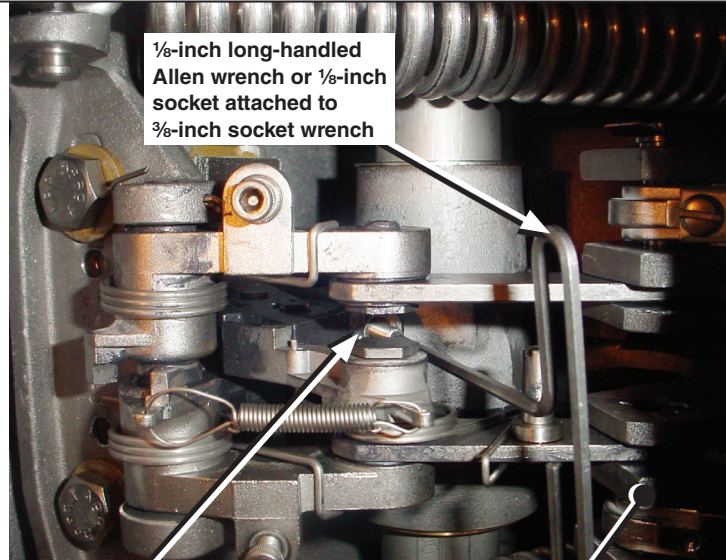

Figure 5. Latch gap on a non-shunt-trip equipped Mark V or Mark IV Circuit-Switcher