

Installation

Table of Contents

Introduction	2	Shipping and Handling	9
Qualified Persons	2	Inspection	9
Read this Instruction Sheet	2	Packing	9
Retain this Instruction Sheet	2	Handling.....	10
Proper Application.....	2	Battery	11
Warranty.....	3	Charging the Battery	11
Warranty Qualifications	3	Installation	13
Safety Information	4	Access to the Interior.....	13
Understanding Safety-Alert Messages	4	Placing the Gear	15
Following Safety Instructions.....	4	Cable Terminations.....	16
Replacement Instructions and Labels	4	S&C 600:5 Current Sensors	20
Location of Safety Labels	5	Fault Indicators	22
Safety Precautions	7	Completing the Installation.....	23
Overview	8	Dielectric Testing	25



Introduction

Qualified Persons

WARNING

Only qualified persons knowledgeable in the installation, operation, and maintenance of overhead and underground electric distribution equipment, along with all associated hazards, may install, operate, and maintain the equipment covered by this publication. A qualified person is someone trained and competent in:

- The skills and techniques necessary to distinguish exposed live parts from nonlive parts of electrical equipment
- The skills and techniques necessary to determine the proper approach distances corresponding to the voltages to which the qualified person will be exposed
- The proper use of special precautionary techniques, personal protective equipment, insulated and shielding materials, and insulated tools for working on or near exposed energized parts of electrical equipment

These instructions are intended only for such qualified persons. They are not intended to be a substitute for adequate training and experience in safety procedures for this type of equipment.

Read this Instruction Sheet

NOTICE

Thoroughly and carefully read this instruction sheet and all materials included in the product's instruction handbook before installing or operating remote supervisory PMH Pad-Mounted Gear. Become familiar with the Safety Information on pages 4 through 6 and Safety Precautions on page 7. The latest version of this publication is available online in PDF format at sandc.com/en/contact-us/product-literature/.

Retain this Instruction Sheet

This instruction sheet is a permanent part of remote supervisory PMH Pad-Mounted Gear. Designate a location where users can easily retrieve and refer to this publication.

Proper Application

WARNING

The equipment in this publication is only intended for a specific application. The application must be within the ratings furnished for the equipment. Ratings for remote supervisory PMH Pad-Mounted Gear are listed in the ratings table in Specification Bulletin 664-31. The ratings are also on the nameplate affixed to the product.

Warranty

The warranty and/or obligations described in S&C's Price Sheet 150, "Standard Conditions of Sale—Immediate Purchasers in the United States," (or Price Sheet 153, "Standard Conditions of Sale—Immediate Purchasers Outside the United States"), plus any special warranty provisions, as set forth in the applicable product-line specification bulletin, are exclusive. The remedies provided in the former for breach of these warranties shall constitute the immediate purchaser's or end user's exclusive remedy and a fulfillment of the seller's entire liability. In no event shall the seller's liability to the immediate purchaser or end user exceed the price of the specific product that gives rise to the immediate purchaser's or end user's claim. All other warranties, whether express or implied or arising by operation of law, course of dealing, usage of trade or otherwise, are excluded. The only warranties are those stated in Price Sheet 150 (or Price Sheet 153), and THERE ARE NO EXPRESS OR IMPLIED WARRANTIES OF MERCHANTABILITY OR FITNESS FOR A PARTICULAR PURPOSE. ANY EXPRESS WARRANTY OR OTHER OBLIGATION PROVIDED IN PRICE SHEET 150 (OR PRICE SHEET 153) IS GRANTED ONLY TO THE IMMEDIATE PURCHASER AND END USER, AS DEFINED THEREIN. OTHER THAN AN END USER, NO REMOTE PURCHASER MAY RELY ON ANY AFFIRMATION OF FACT OR PROMISE THAT RELATES TO THE GOODS DESCRIBED HEREIN, ANY DESCRIPTION THAT RELATES TO THE GOODS, OR ANY REMEDIAL PROMISE INCLUDED IN PRICE SHEET 150 (OR PRICE SHEET 153).

**Warranty
Qualifications**

The standard warranty contained in the seller's standard conditions of sale (as set forth in Price Sheet 150) does not apply to remote supervisory PMH Pad-Mounted Gear where fuse units, fuse unit end-fittings, holders, refill units, or switch blades of other than S&C manufacture are used in conjunction with S&C SML Mountings. Nor does it apply to remote supervisory PMH Pad-Mounted Gear where other than Fault Fiter® Electronic Power Fuses, S&C Switch Blades, or the current-limiting fuses listed in Table 1 of S&C Information Bulletin 660-50 are used in conjunction with Fault Fiter Electronic Power Fuse mountings and S&C Holders designed therefor, or when current-limiting fuses are applied other than as set forth in the "Recommended Voltage Ratings" section of S&C Information Bulletin 660-50.

The seller's standard warranty does not apply to major components not of S&C manufacture, such as remote terminal units and communication devices, including hardware, software, resolution of protocol-related matters, and notification of upgrades or fixes for those devices.

Safety Information

Understanding Safety-Alert Messages

Several types of safety-alert messages may appear throughout this instruction sheet and on labels and tags attached to the product. Become familiar with these types of messages and the importance of these various signal words:

DANGER

“DANGER” identifies the most serious and immediate hazards that will likely result in serious personal injury or death if instructions, including recommended precautions, are not followed.

WARNING

“WARNING” identifies hazards or unsafe practices that can result in serious personal injury or death if instructions, including recommended precautions, are not followed.

CAUTION

“CAUTION” identifies hazards or unsafe practices that can result in minor personal injury if instructions, including recommended precautions, are not followed.

NOTICE

“NOTICE” identifies important procedures or requirements that can result in product or property damage if instructions are not followed.

Following Safety Instructions

If any portion of this instruction sheet is unclear and assistance is needed, contact the nearest S&C Sales Office or S&C Authorized Distributor. Their telephone numbers are listed on S&C’s website sandc.com, or call the S&C Global Support and Monitoring Center at 1-888-762-1100.

NOTICE

Read this instruction sheet thoroughly and carefully before installing remote supervisory PMH Pad-Mounted Gear.



Replacement Instructions and Labels

If additional copies of this instruction sheet are required, contact the nearest S&C Sales Office, S&C Authorized Distributor, S&C Headquarters, or S&C Electric Canada Ltd.

It is important that any missing, damaged, or faded labels on the equipment be replaced immediately. Replacement labels are available by contacting the nearest S&C Sales Office, S&C Authorized Distributor, S&C Headquarters, or S&C Electric Canada Ltd.

Location of Safety Labels

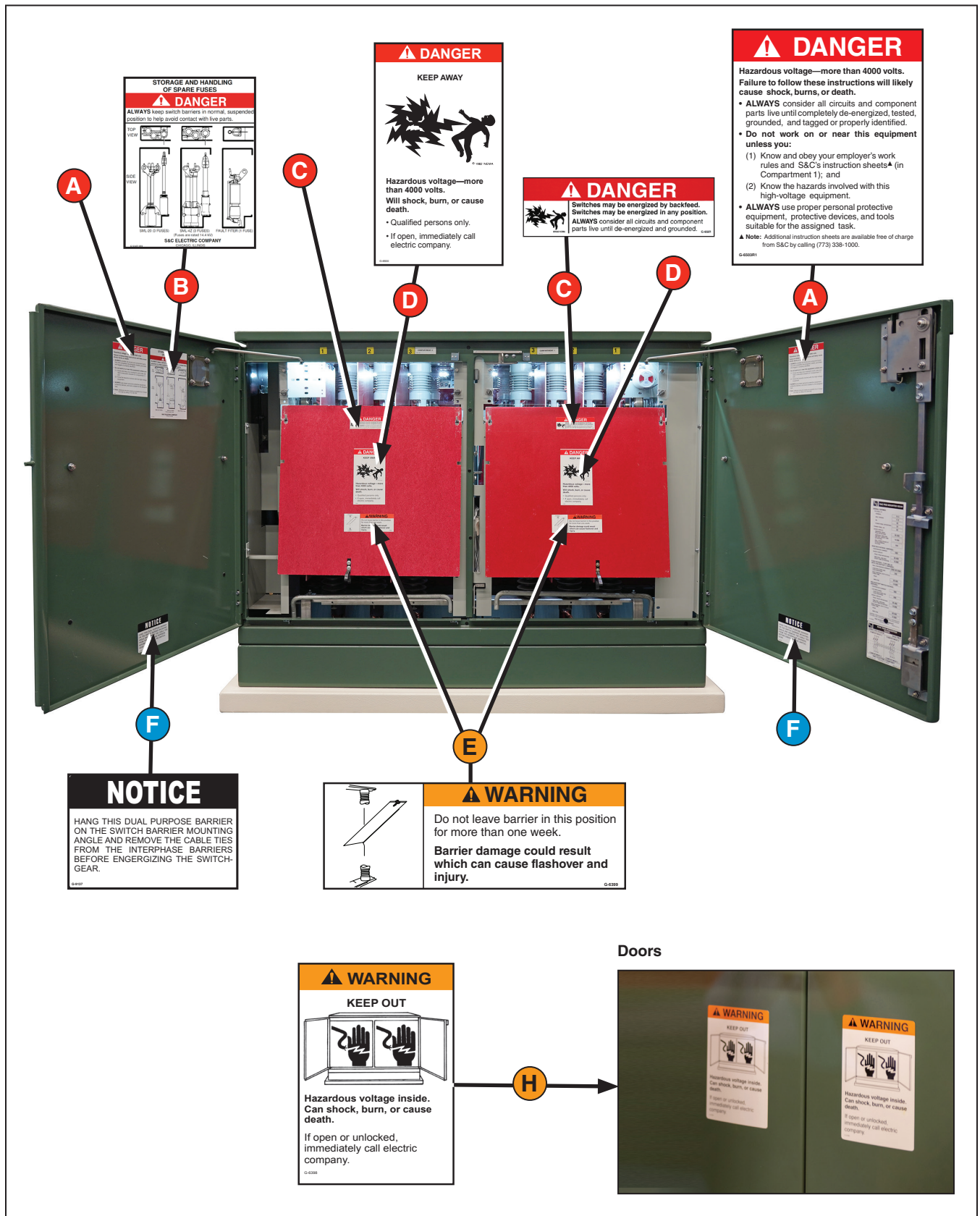

Safety Information

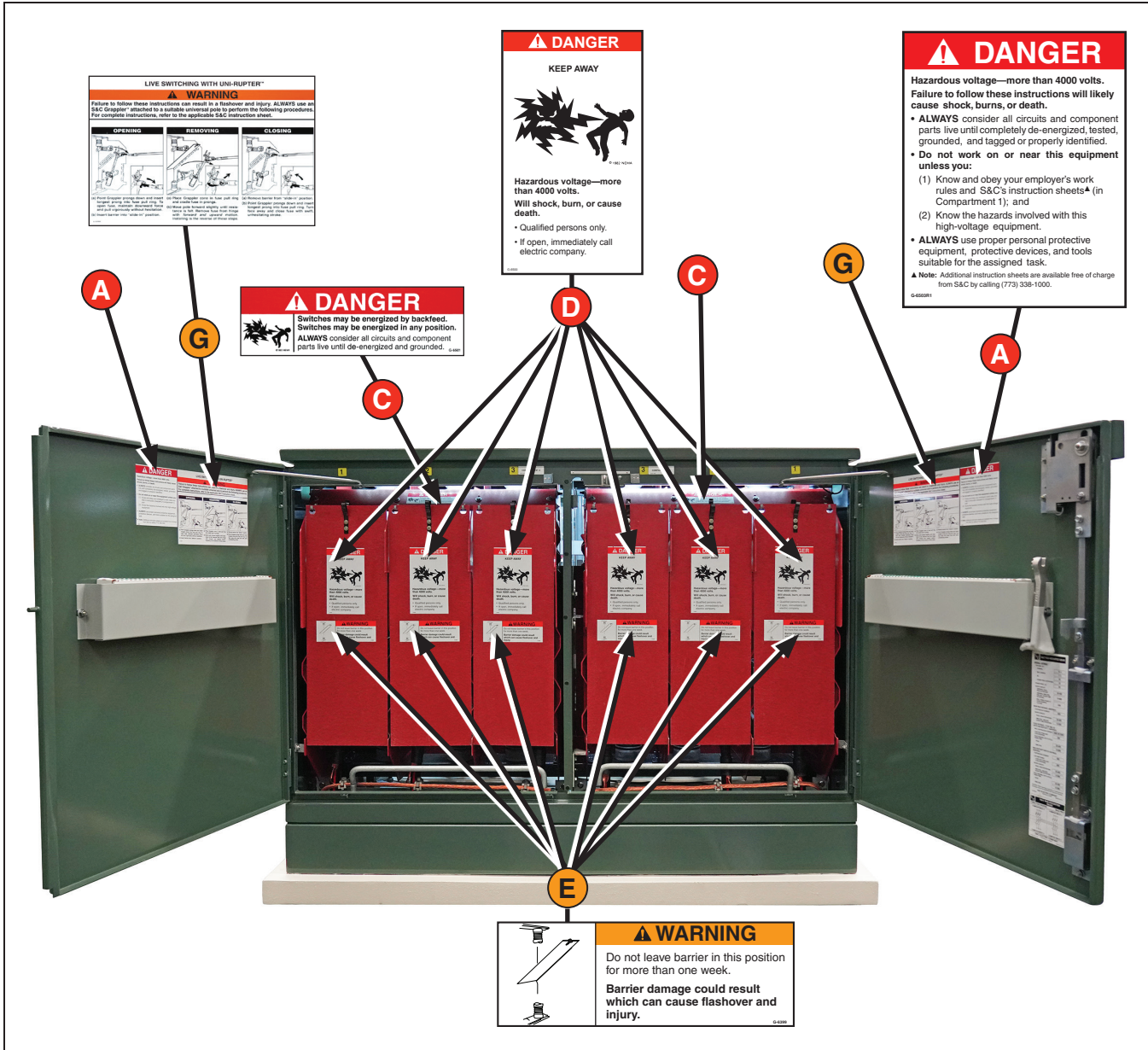

Reorder Information for Safety Labels

Location	Safety Alert Message	Description	Part Number
A	⚠ DANGER	Hazardous voltage —more than 400 volts . . .	G-6503
B	⚠ DANGER	Storage and handling of spare fuses	G-5147-1R1
C	⚠ DANGER	Switches may be energized . . .	G-6501
D	⚠ DANGER	Keep away. . .	G-6500
E	⚠ WARNING	Do not leave barrier in this position . . .	G-6399
F	NOTICE	Hang this dual purpose barrier . . .	G-9137
G	⚠ WARNING	Live switching with Uni-Rupter . . .	G-6369
H	⚠ WARNING	Keep out . . .	G-6398

⚠ DANGER



Remote supervisory PMH Pad-Mounted Gear operates at high voltage. Failure to observe the precautions below will result in serious personal injury or death.

Some of these precautions may differ from company operating procedures and rules. Where a discrepancy exists, follow your company's operating procedures and rules.

1. **QUALIFIED PERSONS.** Access to remote supervisory PMH Pad-Mounted Gear must be restricted only to qualified persons. See the "Qualified Persons" section on page 2.
2. **SAFETY PROCEDURES.** Always follow safe operating procedures and rules.
3. **PERSONAL PROTECTIVE EQUIPMENT.** Always use suitable protective equipment, such as rubber gloves, rubber mats, hard hats, safety glasses, and flash clothing, in accordance with safe operating procedures and rules.
4. **SAFETY LABELS.** Do not remove or obscure any of the "DANGER," "WARNING," "CAUTION," or "NOTICE" labels.
5. **HIGH-VOLTAGE ISOLATION.** Switch operators and controls are isolated from high voltage in grounded, metal-enclosed compartments. Access to these components is controlled by padlockable covers, which incorporate a nonremovable manual handle. Other low-voltage components, such as meters, selector switches, toggle switches, etc., are similarly isolated.
6. **TEST FOR VOLTAGE.** Test for voltage using proper high-voltage test equipment before touching any device to be inspected, serviced, or repaired in the high-voltage compartments.
7. **ENERGIZED COMPONENTS.** Always consider all parts live until de-energized, tested, and grounded. Voltage levels can be as high as the peak line-to-ground voltage last applied to the unit. Units energized or installed near energized lines should be considered live until tested and grounded.
8. **GROUNDING.** Remote supervisory PMH Pad-Mounted Gear must be connected to a suitable earth ground at the base of the utility pole, or to a suitable building ground for testing, before energizing the switchgear and at all times when energized.

The ground wire(s) must be bonded to the system neutral, if present. If the system neutral is not present, proper precautions must be taken to ensure the local earth ground or building ground cannot be severed or removed.
9. **MAINTAINING PROPER CLEARANCE.** Always maintain proper clearance from energized components.
10. **GROUNDING EQUIPMENT.** Install suitable grounding equipment before touching any device to be inspected, serviced, or repaired in the high-voltage compartments.
11. **PADLOCKS.** Non-removable, manual handles in high-voltage compartment doors and hinged-padlockable covers, as well as hinged-bolted panels, have provisions for padlocks that must be in place and secured at all times unless work is being performed inside the enclosure. Padlocks must be installed and secured on manual switch operating handles at all times unless the switch is being operated.
12. **KEY INTERLOCKS.** Key interlocks (if applicable) must be in place. Check the operating sequence of key interlocks to verify proper sequencing. After the switchgear is installed, destroy all duplicate keys or make them accessible only to authorized persons so the key interlock scheme will not be compromised. Key interlocks are not security locks.
13. **MECHANICAL CABLE INTERLOCKS.** Mechanical cable interlocks are provided to prevent access to fuses unless the switch is open and to prevent operation of stored-energy switch operators when the enclosure door is open. Do not attempt to operate any switch when the enclosure door is open. Periodically, verify these interlocks are functional.
14. **DO NOT APPLY UNDUE FORCE.** Do not apply any undue force when attempting to open a door. The use of undue force may damage the door-latching mechanism. If optional key interlocks are provided, make certain the interlocks are in their correct positions to allow door opening.
15. **FUSES MUST BE DISCONNECTED.** Make sure fuses are disconnected from all power sources (including backfeed) before being inspected or replaced.

Overview

The following instructions cover installation of remote supervisory PMH Pad-Mounted Gear. These units are equipped with Type PM Switch Operators for power operation of Mini-Rupter® Switches in response to remote or local pushbutton signals. They also include a low-voltage compartment, an interconnecting control-wiring base spacer, and a control equipment group that includes a combination of sensing, power, communication, and switch-control equipment suited to the particular needs of the application.

The catalog number stamped on the nameplates affixed to the outside of the doors of the pad-mounted gear is suffixed with letter-number combinations. These suffixes indicate the applicable control equipment group (catalog number suffixes “-Y2” through “-Y7”) and also designate the inclusion of optional features, such as key interlocks (catalog number suffix “-C1” “-C3,” or “-C4”). Refer to S&C Specification Bulletin 664-31 for a listing of the available control equipment groups and options for the gear.

Inspection

Examine the shipment for external evidence of damage as soon after receipt as possible, preferably before removal from the carrier's conveyance. Check the bill of lading to make sure all listed shipping skids, crates, and containers are present.

If there is visible loss and/or damage:

1. Notify the delivering carrier immediately.
2. Ask for a carrier inspection.
3. Note condition of shipment on all copies of the delivery receipt.
4. File a claim with the carrier.

If concealed damage is discovered:

1. Notify the delivering carrier within 15 days of receipt of shipment.
2. Ask for a carrier inspection.
3. File a claim with the carrier.

Also, notify S&C Electric Company in all instances of loss or damage.

Packing

Remote supervisory PMH Pad-Mounted Gear is fastened to a wood skid for shipment. Any components specified, such as fuses, refill units, fuse holders, end-fittings, etc., are packed separately and shipped within the enclosure.

At the first opportunity, remove all packing materials (cardboard, paper, foam padding, etc.) from the outside of the gear. This will prevent the finish from being damaged by rainwater absorbed by the packing materials and will also prevent wind-induced abrasion from loose cardboard.

Handling

WARNING

When handling the gear with an overhead hoist, observe standard lifting practices as well as the following general instructions.

Failure to follow these precautions can result in injury and equipment damage.

Follow these steps to lift and move the pad-mounted gear:

- STEP 1.** Make sure the lifting tabs are securely bolted to the enclosure before lifting the gear.
- STEP 2.** Use 6-foot (183-cm) or longer hoist slings of equal length to prevent overstressing the enclosure during lifting.

WARNING

Because the side of the gear where the low-voltage control compartment is located is heavier than the other side, the gear will tilt when lifting.

Care must be taken when lifting the gear to avoid injury and equipment damage.

- STEP 3.** Arrange the hoist slings to distribute the lifting forces equally between the lifting tabs. See Figure 1.
- STEP 4.** Avoid sudden starts and stops.

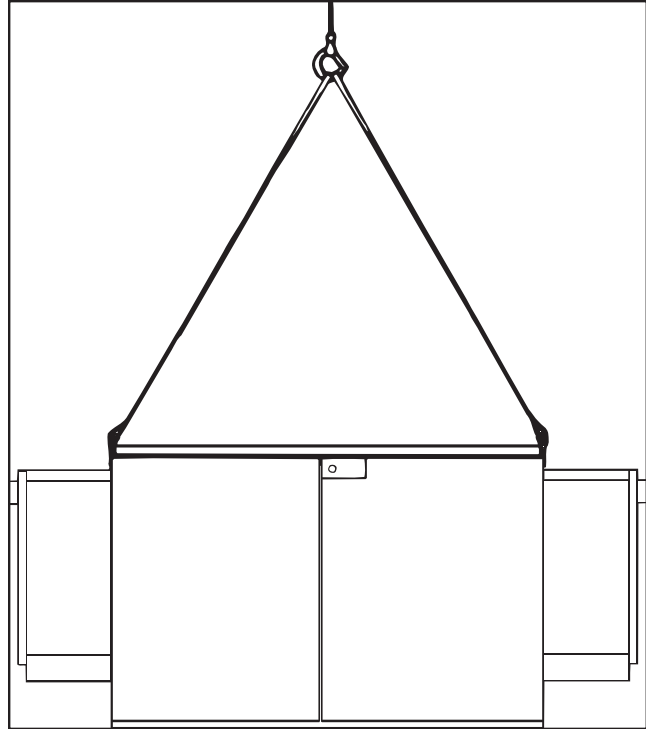

Figure 1. The hoist sling arrangement.

Depending on the control equipment group specified, remote supervisory PMH Pad-Mounted Gear may include an S&C Battery Charger and battery packs.

When furnished, the battery charger and battery packs are installed in the switch operator located on the left side of Compartment 1 for PMH-3 and PMH-5 Models or in Compartment 2 for all other models.

NOTICE

Remote supervisory pad-mounted gear furnished with a battery charger and battery packs should be installed and energized immediately. If the gear cannot be installed immediately, store it in a clean, cool, dry room or remove the battery packs and store them in a cool, dry place. See S&C Instruction Sheet 669-515 for instructions on removing the battery packs. Storing the battery packs at high temperatures reduces their operating life.

If the battery packs are not removed while the gear is in storage, make sure the POWER ON/OFF switch on the battery charger is in the **Off** position. See Figure 2 on page 12. The power will be drained from the battery packs if the switch is in the **On** position.

If the gear is not placed in service by the date on the tag attached to the switch operator containing the battery packs, the battery packs must be charged. **The battery packs will be damaged if allowed to discharge completely.**

Charging the Battery

If the pad-mounted gear has not been placed in service by the date on the tag attached to the switch operator containing the battery, the battery charger must be connected to a transformer-isolated 120-Vac power source. There are two 12-Vdc battery packs. See Figure 2 on page 12.

Follow these steps to connect a 120-Vac power source to the battery charger:

- STEP 1.** Open the switch operator door as described in the “Access to Interior” section on page 13.
- STEP 2.** Make sure the POWER ON/OFF switch on the battery charger is in the **Off** position.
- STEP 3.** Using a voltmeter, check the open-circuit voltage of each battery pack by placing the probes on the appropriate “+” and “-” terminals on the battery charger. One set of terminals is provided for each battery pack.
 - (a) If the open-circuit voltage of either battery pack is less than 10 Vdc, both battery packs must be replaced. Refer to S&C Instruction Sheet 669-515 for instructions about replacing the battery packs. Then, proceed to Step 7.
 - (b) If the open-circuit voltage of both battery packs is 10 Vdc or greater, continue with Step 4.
- STEP 4.** Place the battery-charger INPUT SELECTION switch in the **External Source** position.
- STEP 5.** Connect a transformer-isolated 120-Vac power source to the two EXT/AC terminals on the battery charger. Place the POWER ON/OFF switch on the battery charger in the **On** position and charge the battery for 24 hours.
- STEP 6.** After charging the battery, place the POWER ON/OFF switch on the battery charger in the **Off** position. Then, disconnect the 120-Vac power source, and place the battery-charger INPUT SELECTOR switch in the **Voltage Sensor Source** position.
- STEP 7.** Secure the switch operator door.

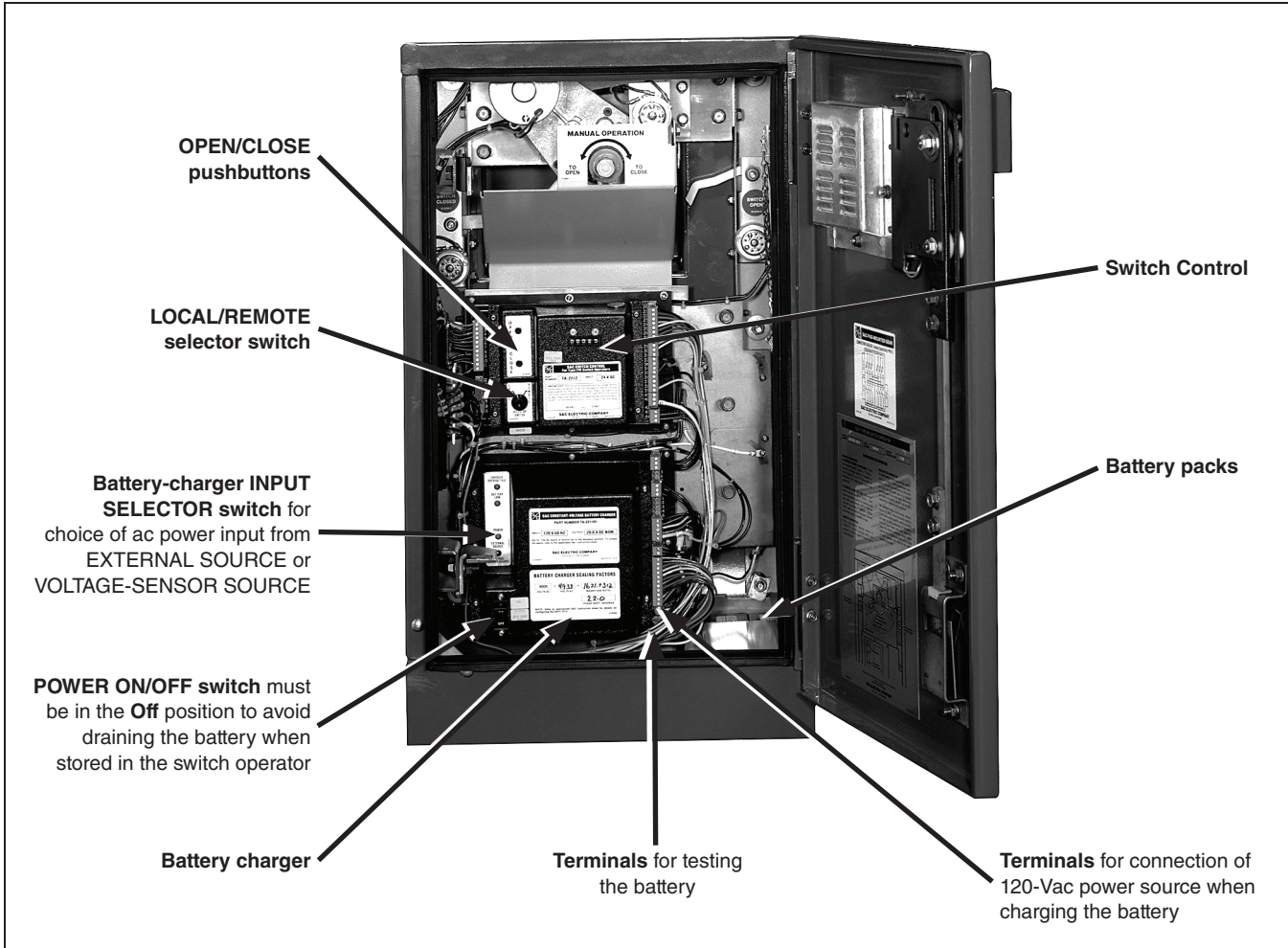

Figure 2. Interior view of the Type PM Switch Operator showing battery packs and battery charger.

Access to the Interior

Access to the interior of pad-mounted gear and its low-voltage control compartment is controlled by the Penta-Latch® Mechanism, which must be opened with a pentahead socket wrench or tool, except when hexhead actuators are specified.

The latching mechanism is coordinated with the provisions for padlocking so the mechanism can be unlatched only after the padlock has been removed. The padlock can be installed only after the door has been securely closed and completely latched.

Follow these steps to open the doors:

Opening the Front Doors

NOTICE
Do not force the doors open. Forcing a door can damage the latching mechanism.

STEP 1. Use a pentahead socket wrench or tool (a hexhead socket wrench or tool when catalog number suffix “-B1” or “-B2” is specified) to unlatch the Penta-Latch Mechanism by rotating the actuator counterclockwise approximately 60° against spring resistance until a distinct click is heard and the actuator reaches its stop. See Figure 3. This single motion unlatches the mechanism and recharges the latching spring for the subsequent closing operation.

STEP 2. Pull the door open and secure it with the door holder. See Figure 4.

NOTICE
If optional key interlocks are furnished, correctly position the interlocks so the doors can be opened.



Figure 3. To unlock the doors, turn the pentahead socket wrench 60° counterclockwise against spring resistance until a “click” is heard and the wrench reaches its stop.

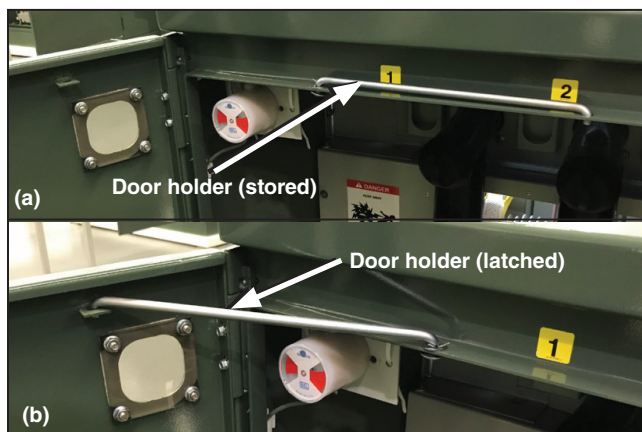

Figure 4. Using the door holder to hold the door open.

Installation

STEP 3. *For double-door models of pad-mounted gear:* The left-hand door to the interior of the gear is secured closed by a rotating latch and is overlapped by the right-hand door, which is equipped with the Penta-Latch Mechanism. The left-hand door can be opened after opening the right-hand door, removing the tie wrap securing it for shipment, and disengaging the rotating latch by rotating it upward. See Figure 5.

The left-hand door to the low-voltage control compartment is secured closed by two captive screws and is overlapped by the right-hand door. This door can be opened after opening the right-hand door and loosening the screws securing it closed.

Closing the Front Doors

Complete the following steps to close the doors:

STEP 1. Close the left-hand door and secure it as appropriate with the captive screws or with the latch by rotating the latch downward over the stop on the outer edge of the door. See Figure 5. The right-hand door latches automatically when the door is closed.

To close a door equipped with the Penta-Latch mechanism: Place one hand at the midpoint of the door-front near the edge and firmly push the door closed. When the latch points are positively engaged, the spring mechanism will trip to latch the door.

STEP 2. Pull outward on the cover of the Penta-Latch Mechanism to verify the door has latched securely. If it has not, use a pentahead (or hexhead, when applicable) socket wrench or tool to rotate the actuator counterclockwise until a distinct click is heard and the actuator reaches the stop.

If the actuator will not rotate counterclockwise, the mechanism was already charged for closing but was not closed properly. Close the door again, making sure all latch points engage completely and simultaneously.

STEP 3. When the door is securely latched, a padlock may be inserted into the hasp.



Figure 5. Rotate the latch upward to disengage the left-hand door, as shown above. To secure the left-hand door closed, rotate the latch downward over the stop on the outer edge of the door.

Placing the Gear

Complete the following steps to place the gear:

- STEP 1.** At the installation site, remove all separately packaged components shipped in the pad-mounted gear enclosure and set them aside in a protected area.
- STEP 2.** Unbolt the enclosure from its skid and lift the unit onto the mounting pad, observing the precautions in the “Shipping and Handling” section on page 9.
- STEP 3.** Open the doors to the interior of the gear and secure them with the door holders.
- STEP 4.** Refer to the catalog dimensional drawing furnished and verify the enclosure compartments are positioned correctly and the unit is properly aligned with respect to the anchor bolts or flush anchors.

Note: If excess lengths of direct-buried cable are in place and they must be fed into the enclosure compartments as the unit is being lowered, the doors must be opened (with door holders in place) to allow any excess cable to feed over the door stiles.

If switch interphase and end-barriers (where applicable) are removed to facilitate this procedure, note their position to ensure correct reinstallation.

It should not be necessary to remove any upper barriers. Refer to Step 1(b) of the “Cable-Termination” section on page 16 for instructions on removal of the switch barriers.

- STEP 5.** Level the pad-mounted gear enclosure using metal shims as required between the mounting pad and the enclosure. Shim the enclosure until the tops of the compartment doors are even. For two-compartment units, shim the enclosure until the top of each door is parallel with the top of the gear.
- STEP 6.** Secure the enclosure to the pad using the anchor brackets provided. See the anchor-bolt detail on the catalog dimensional drawing. Make sure all compartment doors open and latch closed without binding. Binding indicates enclosure distortion which must be corrected with additional shimming.

Installation

Cable Terminations

Complete the following steps to terminate the cables:

- STEP 1.** To facilitate makeup and connection of cable terminations to the switch terminals, switch interphase and end barriers (where applicable) can be removed by loosening the wing-head screw that secures each barrier to the barrier support angle.
- (a) Remove the tie wraps securing the wing-head screws for shipment. The screw will remain attached to the barrier, which is supported at the switch frame by the barrier guide. See Figure 6.
 - (b) Lift the barrier from the guide and place it in a location where the barrier will not be damaged.

- STEP 2.** Optional cable guides, if specified, include cable-support brackets (packed separately) and mounting angles (factory installed when an optional base spacer, 12-inch (30.5-cm) minimum, is specified; packed separately otherwise).

Using the hardware furnished, attach the mounting angles (if packed separately) to the tabs provided on the sidewalls of the compartments and attach the cable-support brackets to the angles. See Figure 6.

Note: Do not remove the protective sheet from the saddle of the bracket or install the cable wrap until instructed to do so in Step 3 on page 18.

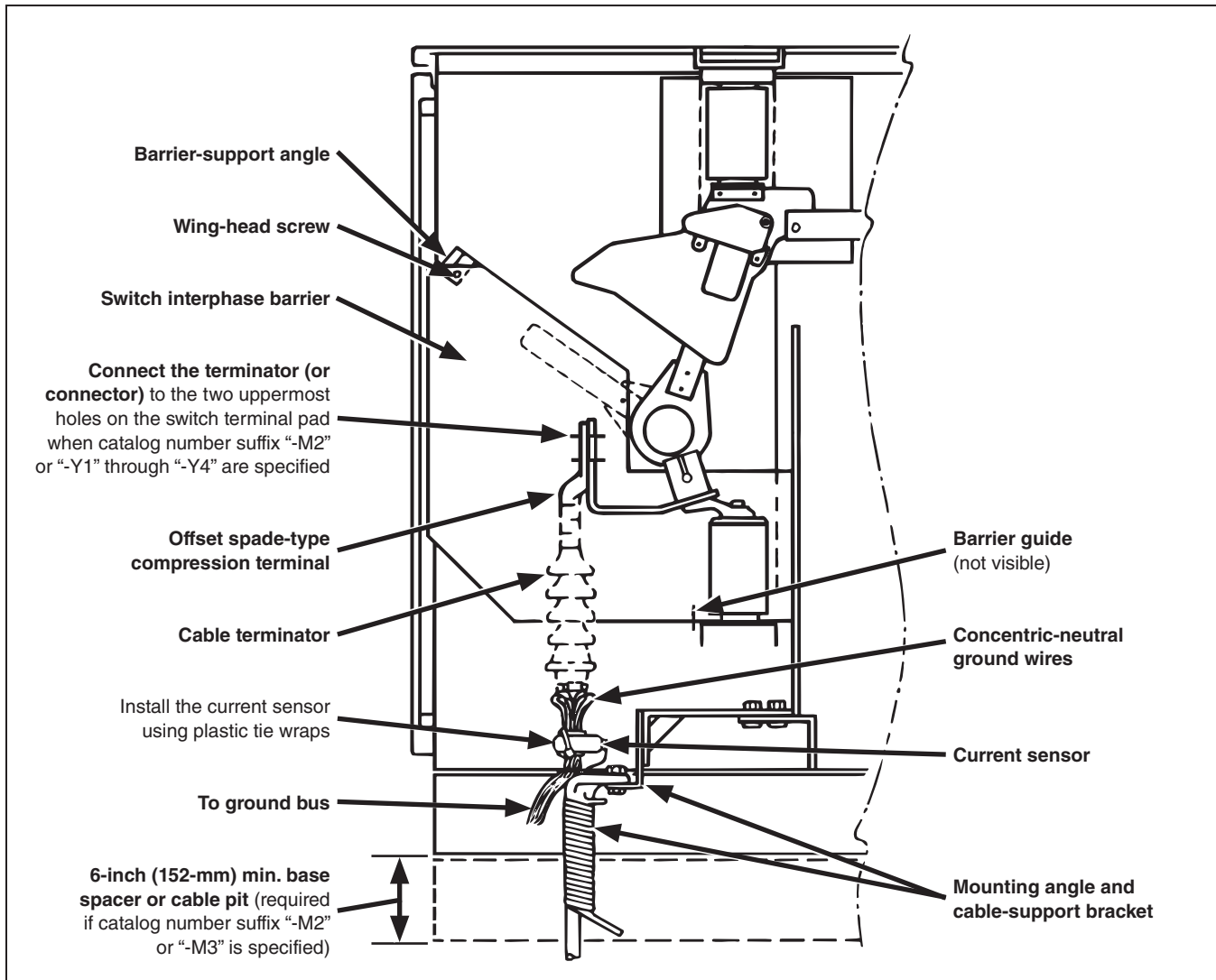

Figure 6. Side view of the switch showing the interphase barrier attachment points, terminal-pad connections, installation of the current sensors (furnished with the optional Overcurrent Lockout feature), and optional cable guides.

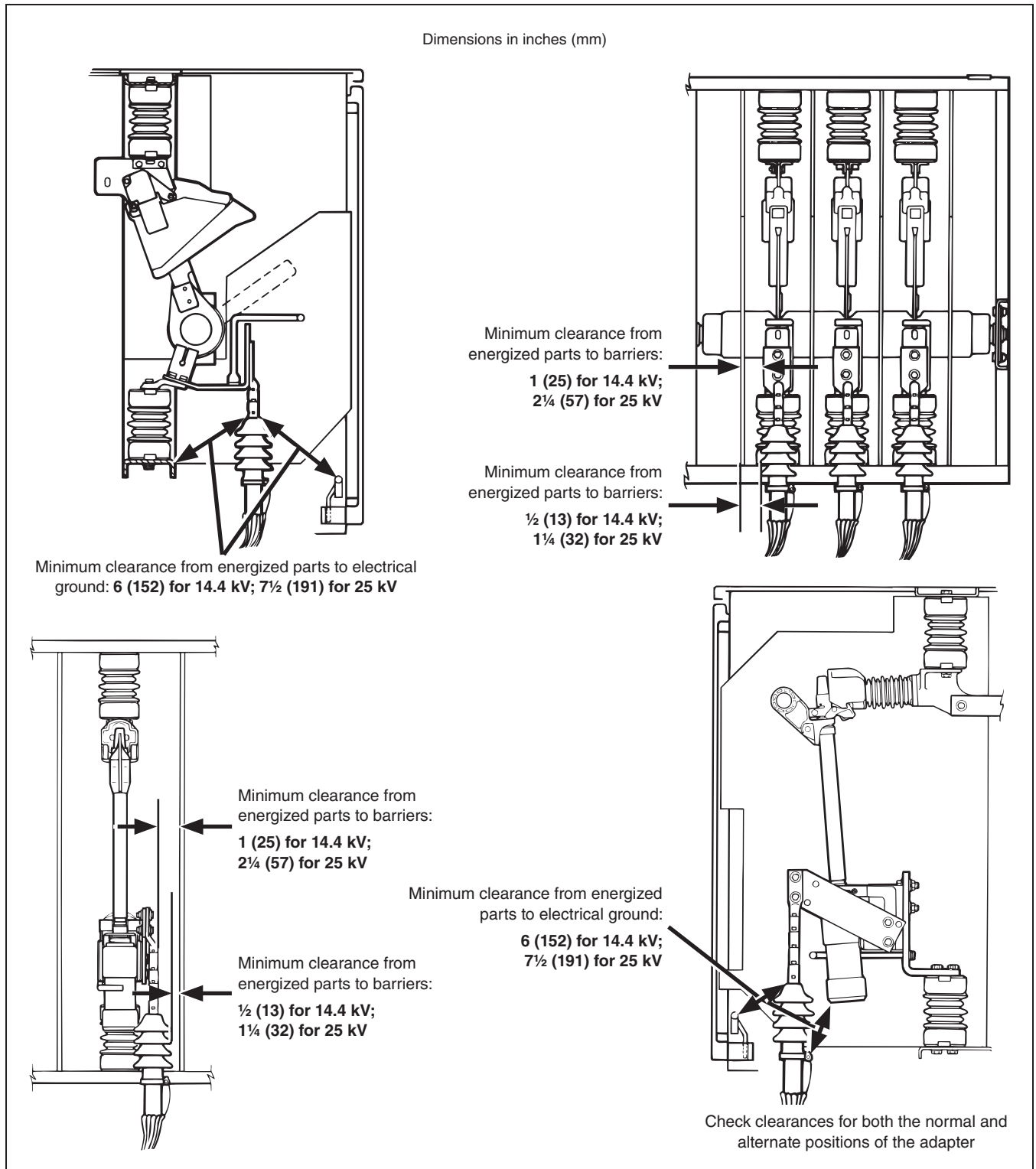

Figure 7. Minimum clearances must be maintained when installing cable terminators.

Installation

STEP 3. Set up cable terminations following the cable-terminator manufacturer's instructions.

WARNING

While the interior of source-transfer PMH Pad-Mounted Gear is protected from direct exposure to the elements, it is inherently an outdoor environment and requires selection and application of cable-terminating devices accordingly. Terminations must incorporate adequate leakage distance between the exposed conductor and the stress-relief cone, across a surface of non-tracking material (or surface rendered non-tracking by properly taping with a suitable material). Furthermore, to maintain the rated BIL, the following minimum clearances are required. See Figure 7 on page 17:

- From energized parts to electrical ground: 6 inches (152 mm) at 14.4 kV; 7½ inches (191 mm) at 25 kV
- From energized parts to fiberglass-reinforced polyester barriers: 1 inch (25 mm) at 14.4 kV; 2¼ inches (57 mm) at 25 kV
- From terminator skirts to fiberglass-reinforced polyester barriers: ½-inch (13 mm) at 14.4 kV; 1¼-inch (32 mm) at 25 kV

Two-position cable-terminator adapters are provided at the fuse hinge assemblies. See Figure 8. These adapters can be placed in their alternate positions when required for increased clearance from energized parts to grounded parts of the cable terminators.

Switch terminal pads are furnished with three mounting holes. In general, cable terminators may be connected to the two lower holes in the switch terminal pads. However, if the pad-mounted gear includes optional cable guides for switch terminals or current sensors, cable terminators must be connected to the two uppermost holes in the switch terminal pads. See Figure 6 on page 16.

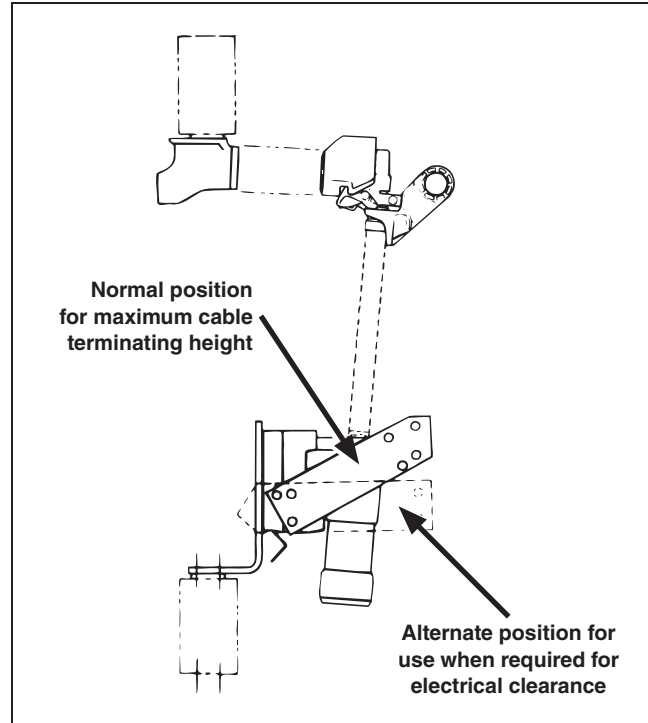

Figure 8. The fuse assembly showing the alternate arrangement of the two-position cable-terminator adapters.

NOTICE

When connecting cable terminators, avoid placing any intentional strain on switch or fuse terminals. Do not use the connecting bolts to pull the cables into alignment. Place each connector flat against the corresponding switch or fuse terminal pad with the bolt holes aligned. **Failure to follow these precautions can cause misalignment of the switch or fuse.**

- STEP 4.** Before connecting the cable terminators to the aluminum terminal pads, thoroughly wire-brush aluminum contact surfaces to remove any dirt or foreign materials as well as natural surface oxides. Immediately coat both contact surfaces to one-half inch (13 mm) beyond the joint with a uniform layer of Penetrox® A. Then, make the connections as follows. See Figure 9.

For aluminum connectors: Use ½-inch aluminum or galvanized steel hardware with two Belleville spring washers (not furnished), as shown in Detail A of Figure 9. Before tightening the connecting bolts, complete the installation of optional cable guides (where applicable) by following the cable-support manufacturer's instructions. Torque aluminum bolts to the manufacturer's specifications. Torque steel bolts to 50 foot-pounds (68 N-m) or, in the absence of a torque wrench, tighten each bolt until the Belleville washers are flat. Then, back off one-half turn. Do not use lock-washers with Belleville washers.

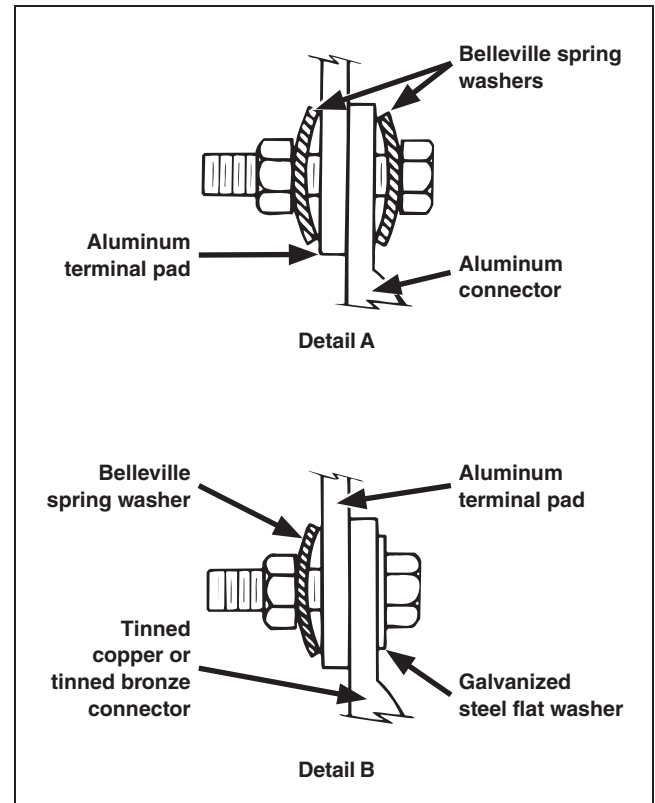

Figure 9. The terminal-pad connections.

For tinned copper or tinned bronze connectors: Use ½-inch galvanized steel hardware with one Belleville spring washer (not furnished) against the aluminum terminal pad and one galvanized steel flat washer against the tinned connector, as shown in Detail B of Figure 9 on page 19. Before tightening the connecting bolts, complete the installation of optional cable guides (where applicable) following the cable-support manufacturer's instructions. Torque the bolts to 50 foot-pounds (68 N-m) or, in the absence of a torque wrench, tighten each bolt until the Belleville washer is flat. Then, back off one-half turn. Do not use lockwashers with Belleville washers.

STEP 5. Connect the cable concentric-neutral ground wires and the ground pads inside the pad-mounted gear enclosure to the system ground facility in accordance with the user's standard grounding practice. Use the equivalent of 4/0 copper cable (or cable sized in accordance with the user's standard practice) in either a single or multiple connection to realize the maximum momentary rating of the gear. For a multiple connection, cables smaller than 1/0 copper or equivalent should not be used .

S&C 600:5 Current Sensors

WARNING

Low-voltage wiring routed inside the pad-mounted gear enclosure must be a minimum of 6 inches (152 mm) at 14.4 kV and 7½ inches (191 mm) at 25 kV away from components that will be energized at high voltage. Do not place wiring where it might fall onto a component that will be energized at high voltage, such as the bus, or where it will be in the way of moving parts.

Failure to maintain proper clearance can result in a flashover, injury, and equipment damage.

NOTICE

Openings made into the low-voltage control compartment must be sealed with a suitable compound to prevent the entry of moisture or animals. **Failure to properly seal the openings can result in damage to the electronic components.**

NOTICE

Do not install the current sensors on unshielded cables or on cables where the insulation is exposed but ungrounded (for example, where dielectric tape or heatshrink tubing is used). These current sensors are intended for application at ground potential and **can be damaged by the voltage gradient between the cable insulation and ground.**

● The use of untinned copper or bronze connectors is not recommended.

Pad-mounted gear equipped with the switch control equipment groups for use with RTU by others includes one set of three S&C 600:5 Current Sensors for each power-operated Mini-Rupter Switch.

Complete the following steps to install the current sensors:

NOTICE

Each S&C Current Sensor has a unique magnitude ratio and phase-angle shift. These values are used to calibrate the current-sensing inputs to a user-supplied RTU. The magnitude ratio and phase-angle shift of each current sensor must be recorded on the yellow card provided in accordance with the compartment and phase on which the current sensor will be installed. The magnitude ratio and phase-angle shift of each current sensor are written on a tag attached to the sensor and on the sensor.

- STEP 1.** Remove the current sensors, hardware, and wiring harness from the box marked “S&C Current Sensors.” Connect the current sensors to the wiring harness, as shown on the instructions provided with the sensors. Also refer to the interconnection wiring diagram provided with the gear.
- STEP 2.** Place each current sensor in front of the phase of the switch compartment on which it will be installed. Note the location of the receptacle on the galvanized-steel cover of the interconnecting-control-wiring base spacer. See Figure 10.
Note: Compartment and phase numbers are located on the upper rail above the door openings of the switch compartments.
- STEP 3.** Record the magnitude ratio and phase-angle shift of each current sensor in the appropriate location (in accordance with the compartment and phase on which the current sensor will be installed) on the yellow card provided in the “Installation and Operation Information Kit.” The magnitude ratio and phase-angle shift of each current sensor are written on a tag attached to the sensor and on the sensor.

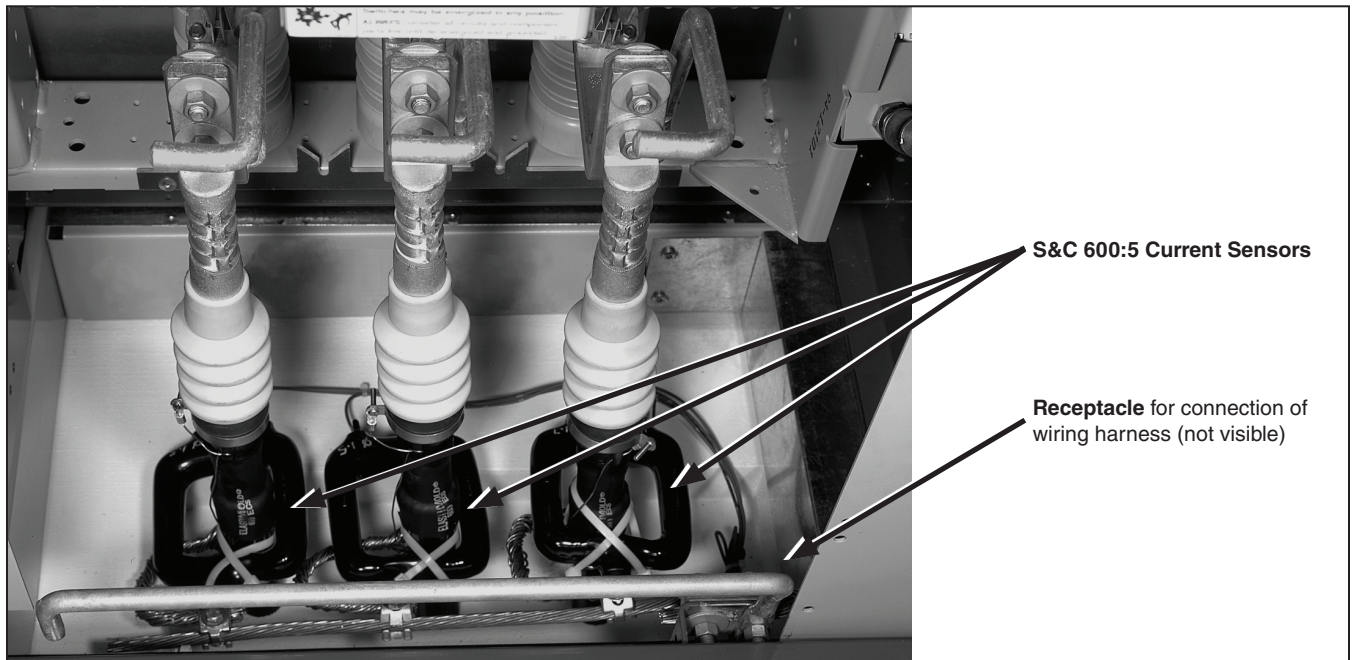

Figure 10. S&C 600:5 Current Sensor installation.

Installation

STEP 4. Remove the ¼–20 gap nut on one of the current sensors. Open the sensor and place it around the appropriate high-voltage cable. All three current sensors in a switch compartment must be installed with the polarity marks facing in the same direction—preferably up, so the magnitude ratio and phase-angle shift values are visible. Then, replace and tighten the gap nut. Refer to Figure 10 on page 21 and Figure 11.

STEP 5. Secure the current sensor to the high-voltage cable below the cable terminator or stress cone using the plastic tie wraps furnished. Refer to Figure 10 on page 21 and Figure 11. If the cable has a grounded concentric neutral, the current sensor must be secured in one of the following ways:

- It may be placed around the concentric neutral, in which case the concentric neutral must be brought back through the current sensor as shown in the left image in Figure 11.

- It may be placed above the concentric neutral, in which case the terminator drain wire must be brought through the sensor as shown in the right image in Figure 11.

STEP 6. Install the other two current sensors of the set by repeating instructions in Step 4 and Step 5.

STEP 7. Plug the current-sensor wiring harness into the receptacle on the galvanized-steel cover of the interconnecting control-wiring base spacer.

STEP 8. Cross-check the magnitude ratio and phase-angle shift of each current sensor with the information recorded on the yellow card.

STEP 9. Remove and discard the attached tags.

Fault Indicators

Optional mounting provisions for fault indicators are available. Fault indicators are to be furnished by the user and installed in accordance with the manufacturer's instructions. If mounting provisions are specified, mount the fault indicators on the mounting brackets and attach the associated sensors to the cables below the cable terminators.

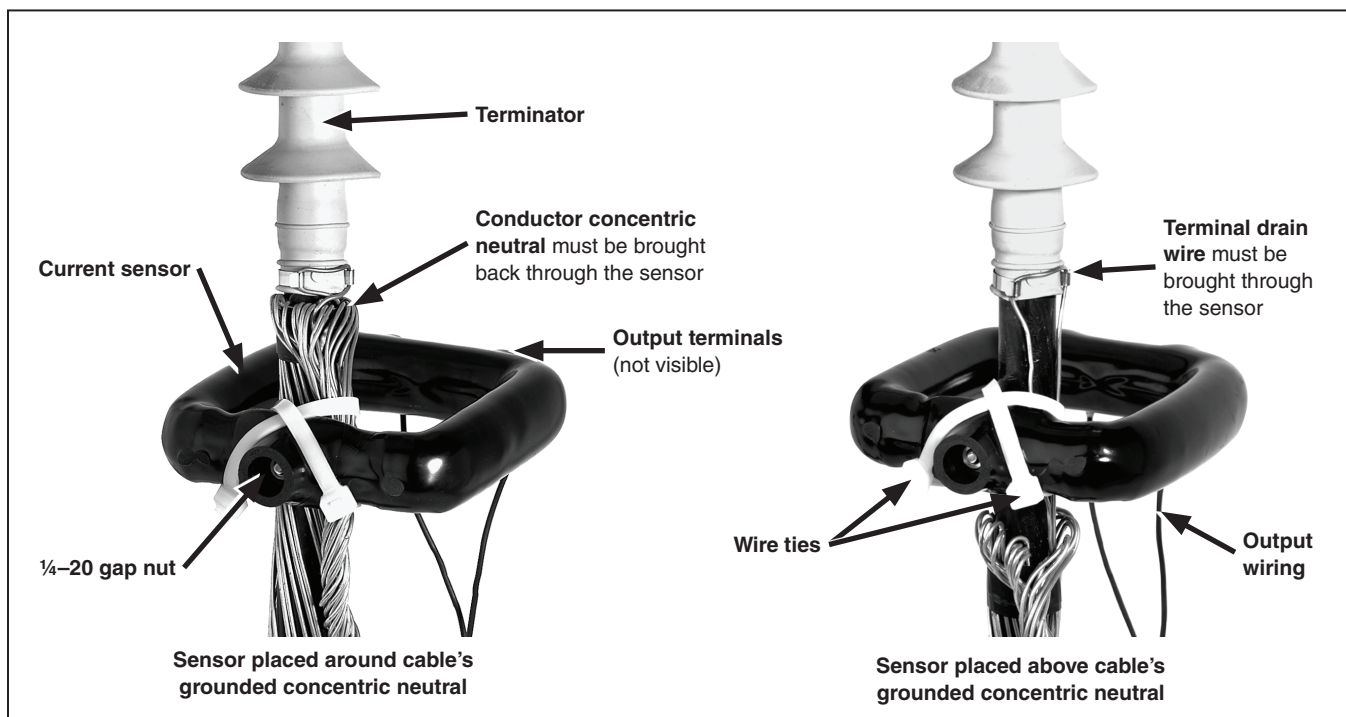

Figure 11. The S&C 600:5 Current Sensors can be placed around the cable concentric neutral (left) or above the cable concentric neutral (right).

Completing the Installation

Complete the following steps to complete the installation:

- STEP 1.** Optional surge arresters and optional mounting provisions for base-mounted surge arresters are available. These options include mounting provisions, surge arresters (when specified), and hard-drawn copper connectors to connect the surge arresters to the terminal pads of the Mini-Rupter Switch.

Install and connect surge arresters in accordance with the manufacturer's instructions.

WARNING

Always use the hard-drawn copper connectors provided to connect the surge arresters to the Mini-Rupter Switch. Do not use flexible leads. **Use of flexible leads can result in a flashover, injury, and equipment damage.**

- STEP 2.** If any switch interphase or end-barriers (where applicable) were removed to facilitate cable termination, reinstall them now. Position the rear of each barrier in the appropriate support notch of the barrier guide mounted on the base of the Mini-Rupter Switch. Then, tighten the wing-head screw of the barrier securely to the barrier-support angle at the front of the switch compartment.

Make sure the clearance from the barriers to energized parts and from the barriers to terminator skirts conforms to the minimum dimensions specified in Step 3 on page 18.

WARNING

Verify the rear of each switch barrier is correctly positioned in its support notch on the switch frame and the front of the barrier is securely fastened to the barrier-support angle. **Failure to properly reinstall the switch barriers will reduce the clearance between the barriers and energized parts or terminator skirts, and can result in a flashover, injury, and equipment damage.**

- STEP 3.** Check the functional operation of key interlocks, if furnished.

WARNING

An extra set of keys is provided with pad-mounted gear that has optional key interlocks. These keys are for use only during installation. After installation, either: (1) destroy the extra set of keys or (2) make them accessible only to authorized persons. This will maintain the integrity of the key-interlock scheme. **Failure to maintain the integrity of the key interlock scheme may lead to equipment damage, personal injury, or death.**

Note: Key interlocks are not security locks and are not a substitute for padlocks.

NOTICE

Do not force doors open. **Forcing a door can damage the latching mechanism.**

If optional key interlocks are furnished, correctly position the interlocks so the doors can be opened.

- STEP 4.** Make sure the doors open and close without binding and the shimming of the pad-mounted gear enclosure is adequate. A resilient closed-cell gasket on the bottom flange of the enclosure protects the finish from being scratched during installation and isolates it from the alkalinity of the concrete foundation. This gasket also helps seal the enclosure to the foundation and guard against entry of rodents, insects, or weeds, and to discourage tampering.

Installation

If the gasket does not compensate for an uneven foundation, grout the bottom of the enclosure as necessary. The grout should be recessed enough to permit caulking. To complete the installation, caulk around the bottom of the enclosure with a weatherproof compound applied with a standard caulking gun. A room-temperature vulcanizing (RTV) silicon-rubber compound is recommended. Apply a suitable compound to fill the spaces between the cable and the conduit, and cap all empty conduits to prevent the entry of moisture or animals.

- STEP 5.** Remove the lifting tabs and replace the bolts to plug the blind-tapped holes.
- STEP 6.** Check the interior of the pad-mounted gear. Remove all foreign materials and tools that may have been mislaid, and sweep the interior clear of debris.
- STEP 7.** Remove the tie wraps securing the dual-purpose barriers to the inside of the door.
- STEP 8.** Wipe barriers, insulators, switches, fuses, and terminators clean with a mineral-spirits solvent and dry with a clean cloth.
- STEP 9.** Hang dual-purpose front barriers in their normal, suspended positions. Also install optional inner barrier panels, if furnished.

WARNING

Dual-purpose front barriers must be wiped clean before placing them in the **Slide In** position. Do not leave the dual-purpose front barriers in the **Slide In** position for more than one week. These barriers are intended for temporary use in the **Slide In** position while work is being performed. If the barriers are left in this position for an extended period of time, there is the possibility of corona discharge to the barriers.

Prolonged exposure to corona discharge can damage the barriers and result in a flashover, injury, and equipment damage.

STEP 10. Store spare SMU-20® Fuse Units or SM-4® Refill Units (as applicable) in the fuse-storage racks inside the fuse-compartment doors. Storage for Fault Fiter Electronic Power Fuses or current-limiting fuses cannot be provided in these racks.

STEP 11. Wipe down the exterior of the enclosure with a clean, damp cloth. To preserve the integrity of the surface, refinish any scratches or abrasions with S&C touch-up finish and red-oxide primer, which are available in aerosol spray cans. See S&C Specification Bulletin 664-31 for catalog number information used for ordering.

No other finish or primer is approved. The area to be touched up should be cleaned to remove all oil and grease. Sand the area, removing any traces of rust that may be present, and make sure all edges are feathered before applying primer.

Note: Labels indicating the area around the pad-mounted gear must be kept clear so work on the gear can be done safely are provided in the “Installation and Operation Information Kit.” These labels (or equivalent labels) should be affixed to the exterior of the gear. Refer to the “Location of Safety Labels” section on pages 5 through 6.

When the installation is completed, refer to S&C Instruction Sheet 664-510 for operating instructions regarding the pad-mounted gear and source-transfer control.

When high-voltage dielectric tests will be performed on remote supervisory PMH Pad-Mounted Gear, special precautions should be taken to prevent damage to the voltage sensors and voltage limiters. Refer to S&C Instruction Sheet 591-500.