

S&C PureWave® UPS System
2.5 MVA – 20 MVA (2 MW – 16 MW)
4 kV – 15 kV



Operation and Maintenance

Table of Contents

Section	Page
Introduction	
Qualified Persons	2
Read this Instruction Sheet.	2
Retain this Instruction Sheet.	2
Proper Application.	2
Warranty	2
Warranty Qualifications.	2
Safety Information	
Understanding Safety-Alert Messages	3
Following Safety Instructions	3
Replacement Instructions and Labels.	3
Hazardous Voltages	3
Safety Equipment, Precautions, and Practices	4
Additional Safety Instructions	4
Location of Safety Labels	5
Safety Precautions	
Insulated Hand Tools	8
Emergency Procedures and Equipment	8
Shipping and Handling	
Inspection	9
Components and Controls	
Enclosure	10
Doors	13
Air Control and Ventilation.	13
Operating Controls	14
Monitoring Computer	14

Section	Page
Operation	
System Operation	15
States	15
Transition States	16
Contacts	16
Remote Disable (Optional)	16
Operating Modes and Procedures	17
Maintenance Bypass Procedure	17
Returning the PureWave UPS System to the Ready State	17
System Emergency Bypass Isolation Procedure	17
Battery Charging Modes	18
Generator Interface	18
Alarms List and Troubleshooting Tips	19
Warning Alarms	19
Inhibit Alarms	22
Bypass Alarms	22
Bypass Isolate Alarms	23
Monitoring	
Overview.	24
Monitoring Software Security	24
Monitoring Software	24
Maintenance	
Overview.	27
Quarterly Maintenance	28
Annual Maintenance	32



Introduction

Qualified Persons

WARNING

The equipment covered by this publication must be installed, operated, and maintained by qualified persons who are knowledgeable in the installation, operation, and maintenance of electric power distribution equipment and the associated hazards. A qualified person is one who is trained and competent in:

- The skills and techniques necessary to distinguish exposed live parts from nonlive parts of electrical equipment
- The skills and techniques necessary to determine the proper approach distances corresponding to the voltage to which the qualified person will be exposed
- The proper use of the special precautionary techniques, personal protective equipment, insulating and shielding materials, and insulated tools for working on or near exposed energized parts of electrical equipment

These instructions are intended only for such qualified persons. They are not intended to be a substitute for adequate training and experience in safety procedures for this type of equipment. Failure to comply can result in personal injury or even death.

Read this Instruction Sheet

NOTICE

Read this instruction sheet thoroughly and carefully before operating your S&C PureWave UPS System. Familiarize yourself with the Safety Information and Safety Precautions on pages 3 through 8. The latest version of this publication is available online in PDF format at sandc.com/Support/Product-Literature.asp.

Retain this Instruction Sheet

This instruction sheet is a permanent part of your PureWave UPS System. It does not include instruction sheets from the original battery manufacturer. Designate a location where you can easily retrieve all information and refer to it.

Proper Application

WARNING

The equipment in this publication must be selected for a specific application. The application must be within the ratings furnished for the equipment.

Warranty

The warranty and/or obligations described in S&C's standard conditions of sale, as set forth in Price Sheet 150, plus any special warranty provisions, as set forth in the applicable product-line specification bulletin, are exclusive. The remedies provided in the former for breach of these warranties shall constitute immediate purchaser's or end user's exclusive remedy and a fulfillment of all seller's liability. In no event shall seller's liability to immediate purchaser or end user exceed the price of the specific product that gives rise to immediate purchaser's or end user's claim. All other warranties, whether express or implied or arising by operation of law, course of dealing, usage of trade or otherwise, are excluded. The only warranties are those stated in Price Sheet 150, and THERE ARE NO EXPRESS OR IMPLIED WARRANTIES OF MERCHANTABILITY OR FITNESS FOR A PARTICULAR PURPOSE. ANY EXPRESS WARRANTY OR OTHER OBLIGATION PROVIDED IN PRICE SHEET 150 IS GRANTED ONLY TO THE IMMEDIATE PURCHASER AND END USER, AS DEFINED THEREIN. OTHER THAN AN END USER, NO REMOTE PURCHASER MAY RELY ON ANY AFFIRMATION OF FACT OR PROMISE THAT RELATES TO THE GOODS DESCRIBED HEREIN, ANY DESCRIPTION THAT RELATES TO THE GOODS, OR ANY REMEDIAL PROMISE INCLUDED IN PRICE SHEET 150.

Warranty Qualifications

The seller's warranties are contingent upon the installation and adjustment of the S&C PureWave UPS System in accordance with S&C's applicable instruction sheets, data sheets, and/or data bulletins.

Understanding Safety-Alert Messages

Several types of safety-alert messages may appear throughout this instruction sheet and on labels attached to crate, packing, and equipment. Familiarize yourself with these types of messages and the importance of these various signal words:

⚠ DANGER
“DANGER” identifies the most serious and immediate hazards that <i>will likely</i> result in serious personal injury or death if instructions, including recommended precautions, are not followed.

⚠ WARNING
“WARNING” identifies hazards or unsafe practices that <i>can</i> result in serious personal injury or death if instructions, including recommended precautions, are not followed.

⚠ CAUTION
“CAUTION” identifies hazards or unsafe practices that <i>can</i> result in minor personal injury if instructions, including recommended precautions, are not followed.

NOTICE
“NOTICE” identifies important procedures or requirements that <i>can</i> result in product or property damage if instructions are not followed.

Following Safety Instructions

If you do not understand any portion of this instruction sheet and need assistance, contact your nearest S&C Sales Office or S&C Authorized Distributor. Their telephone numbers are listed on S&C’s website sandc.com Or call S&C Headquarters at (773) 338-1000; in Canada, call S&C Electric Canada Ltd. at (416) 249-9171.

NOTICE	
Read this instruction sheet thoroughly and carefully before installing or operating your S&C PureWave UPS System.	

Replacement Instructions and Labels

If you need additional copies of this instruction sheet, contact your nearest S&C Sales Office, S&C Authorized Distributor, S&C Headquarters, or S&C Electric Canada Ltd.

It is important that any missing, damaged, or faded labels on the equipment be replaced immediately. Replacement labels are available by contacting your nearest S&C Sales Office, S&C Authorized Distributor, S&C Headquarters, or S&C Electric Canada Ltd.

Hazardous Voltages

⚠ DANGER
Potentially lethal voltages are present inside the PureWave UPS System. Dc voltage is present even without utility power connected. Hazardous voltages should also be expected in all interconnecting components and lines.

To maintain safety, the user should use padlocks on each enclosure door. The doors and the use of the padlocks provide protection against inadvertent contact with high-voltage circuits.

Safety Information

Safety Equipment, Precautions, and Practices

S&C PureWave UPS System and battery instruction sheets must be available to all operators and other employees. If doors to the electrical controllers or panels to the system enclosure must be opened, refer to the instruction sheet for procedures for guarding against electric shock. Lockout and tagout procedures should be developed and implemented in accordance with 29 CFR 1910.147.

Additional Safety Instructions

Consult the supplier of the batteries and metal-clad switchgear for additional safety instructions and procedures.

Location of Safety Labels

NOTICE

For safety labels, contact S&C Electric Company for the following:

- Exact location of the standard safety labels
- Project-specific safety labels
- Instructions on how to replace labels (reference the label part numbers as shown below)

Front of the Enclosure

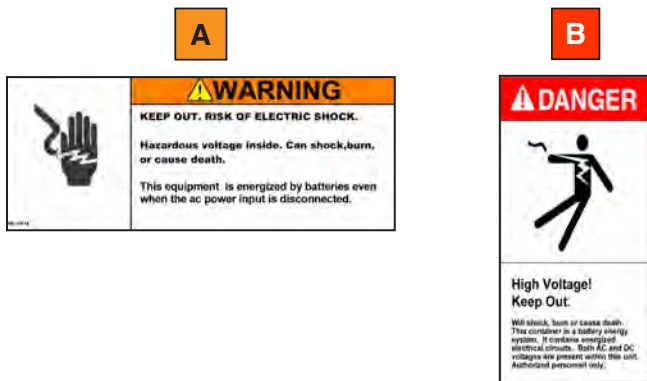
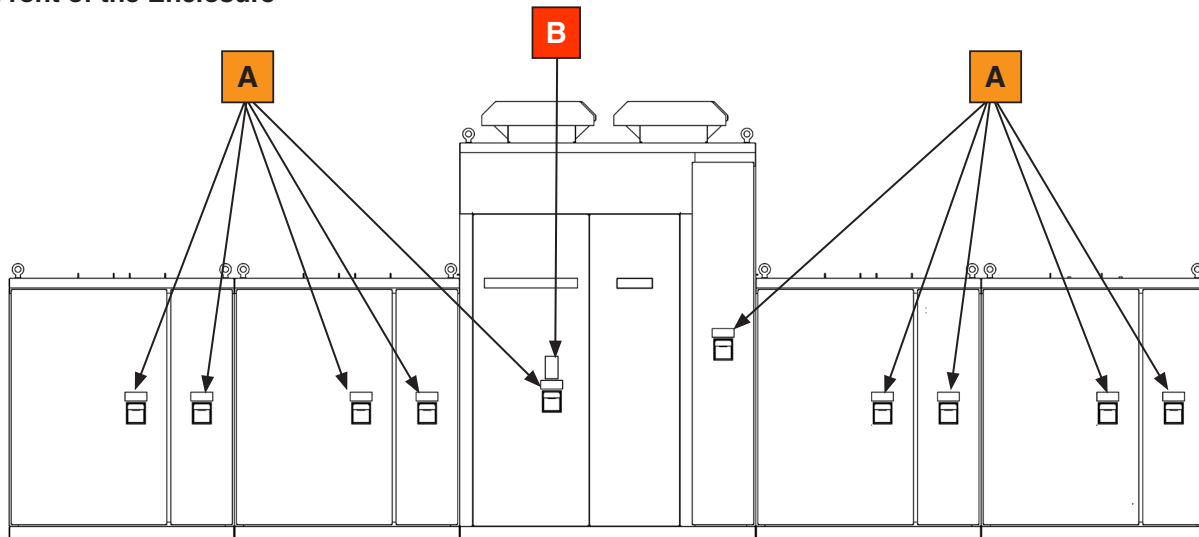

Reorder Information for Safety Labels

Location	Safety Alert Message	Description	Part Number
A	⚠ WARNING	Keep out. Risk of electric shock...	PE-70314
B	⚠ DANGER	High voltage! Keep out.	PE-70236
C	⚠ DANGER	Hazardous voltage...	PE-70315
D	⚠ DANGER	Keep out. Risk of electric shock...	PE-70323
E	⚠ DANGER	Before energizing...	G-6073

Safety Information

Inside of Doors

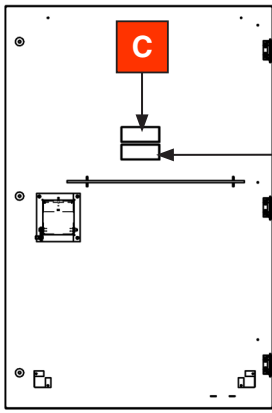

Battery bay door.

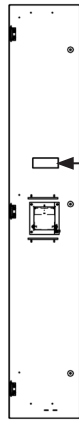

Power conversion module section door.

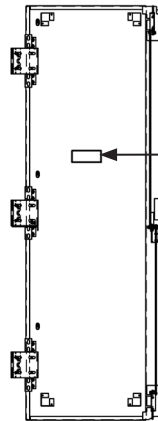

Control bay left door.

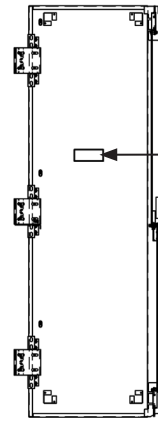

Control bay right door.

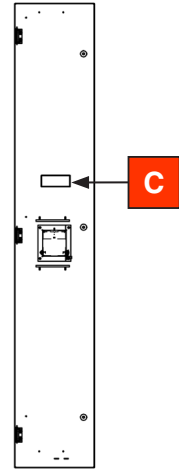

Ac-filter capacitor section door.

Rear of the Enclosure

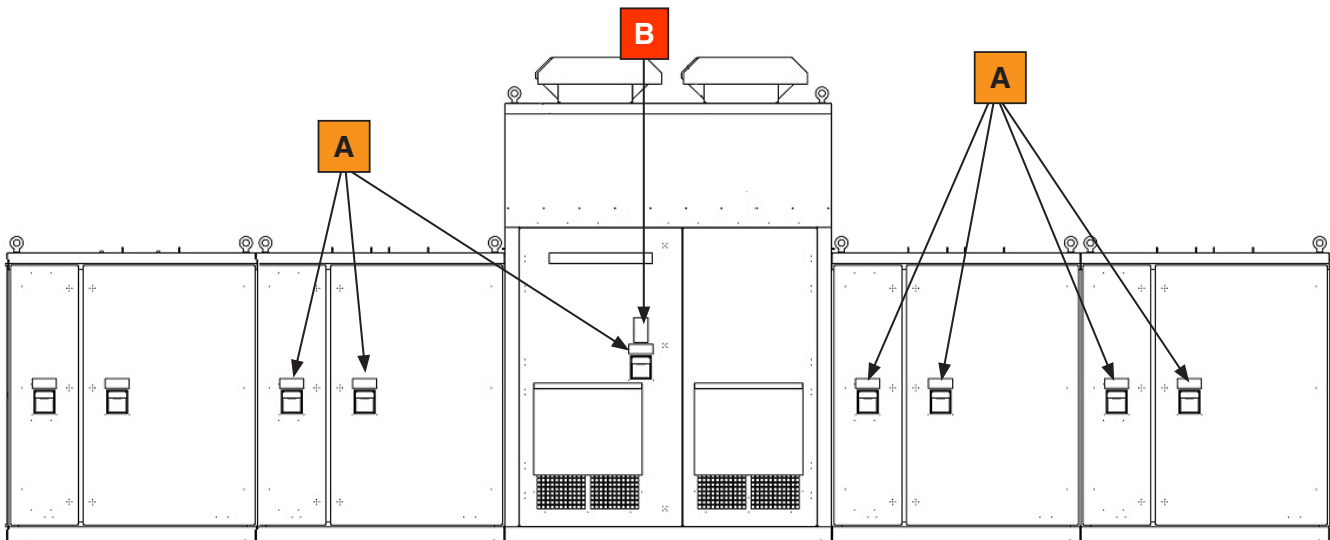

Dead-front panel screens inside the transformer bay

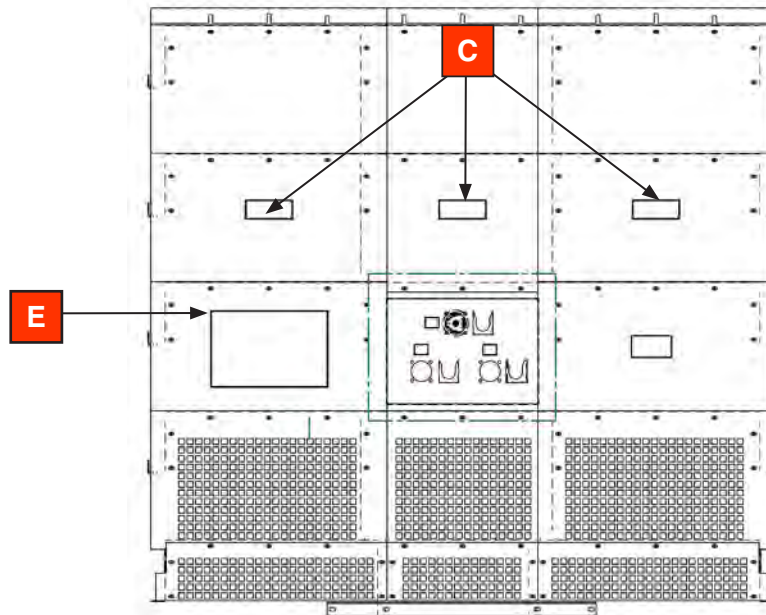

Reorder Information for Safety Labels

Location	Safety Alert Message	Description	Part Number
A	⚠ WARNING	Keep out. Risk of electric shock...	PE-70314
B	⚠ DANGER	High voltage! Keep out.	PE-70236
C	⚠ DANGER	Hazardous voltage...	PE-70315
D	⚠ DANGER	Keep out. Risk of electric shock...	PE-70323
E	⚠ DANGER	Before energizing...	G-6073

Safety Precautions

DANGER



The S&C PureWave UPS System operates at high ac and dc voltages. Failure to observe the precautions below will result in serious personal injury or death.

Some of these precautions may differ from your company's operating procedures and rules. Where a discrepancy exists, follow your company's operating procedures and rules.

1. **QUALIFIED PERSONS.** Access to the PureWave UPS System must be restricted only to qualified persons. See "Qualified Persons" on page 2.
2. **SAFETY PROCEDURES.** Always follow safe operating procedures and rules.
3. **PERSONAL PROTECTIVE EQUIPMENT.** Always use suitable protective equipment such as rubber gloves, rubber mats, hard hats, safety glasses, and flash clothing, in accordance with safe operating procedures and rules.
4. **SAFETY LABELS.** Do not remove or obscure any of the "DANGER," "WARNING," "CAUTION," or "NOTICE" labels.
5. **OPERATING MECHANISM AND BASE.** The PureWave UPS System contains moving parts that can severely injure fingers. Do not remove or disassemble operating mechanism or circuit breakers, or remove dead-front access panels on the PureWave UPS System unless directed by S&C Electric Company.
6. **ENERGIZED COMPONENTS.** Always consider all parts live until de-energized, tested, and grounded.
7. **GROUNDING.** The PureWave UPS System enclosure must be connected to a suitable earth ground or to a suitable building ground for testing before energizing the unit and at all times when energized.
8. **MAINTAINING PROPER CLEARANCE.** Always maintain proper clearance from energized components.

Insulated Hand Tools

Insulated hand tools are required when working on or around any energized equipment. Use only properly rated tools for the energy present. Tool inventories should be kept to ensure that all tools that enter the system enclosure are removed before energizing the system.

Emergency Procedures and Equipment

The owner should develop policies and procedures for handling emergency situations. It is the responsibility of the owner to develop site-specific emergency action plans for response to such situations.

Inspection

After the PureWave UPS System is commissioned and the unit is online, inspection and maintenance should be scheduled on a regular basis to ensure proper system operation.

Enclosure

⚠ DANGER

Do not enter the system enclosures unless trained, certified, and authorized to do so by S&C Electric Company. Physical entry into the enclosure should never be attempted while the system is enabled or when the modules are on-line. Voltages up to 600 Vdc and 15 kVac should be expected under normal operating conditions. Dc voltage is present even without the utility power connected.

The enclosure is meant to provide access for field-troubleshooting purposes only when properly grounded. Never, under any circumstances, open the enclosure doors while it is online or has not been fully discharged and grounded. Failure to do this can result in equipment damage, personal injury, or even death.

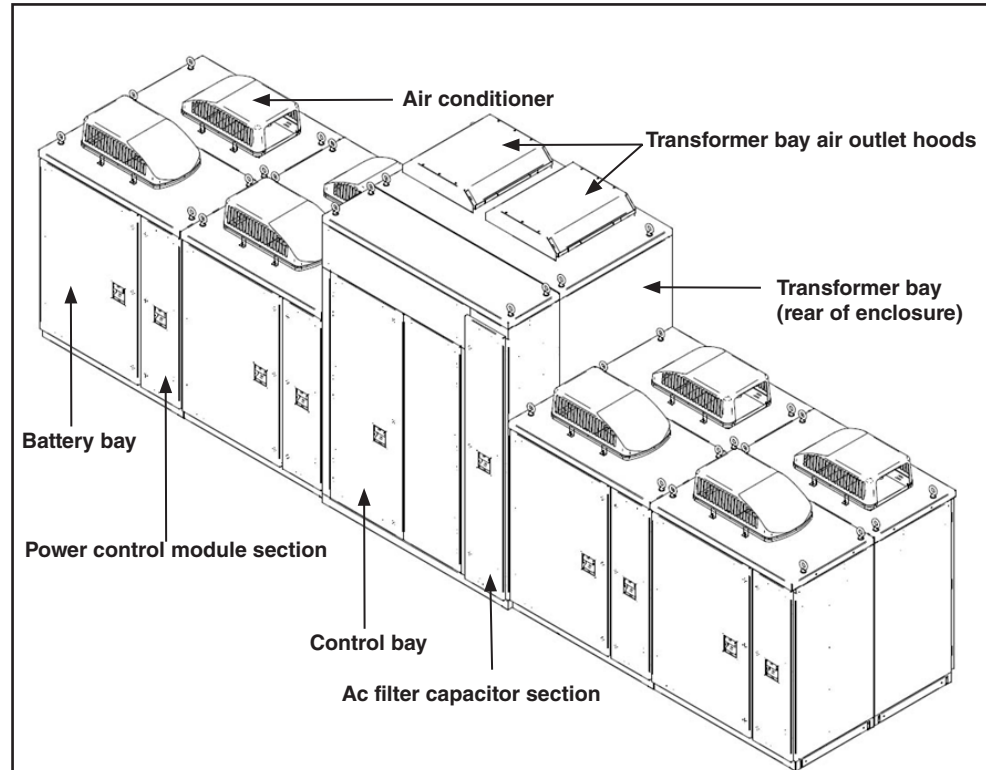

Figure 1. Location of the bays, sections, and components of a 2.25-MW/2.5-MVA PureWave UPS System enclosure.

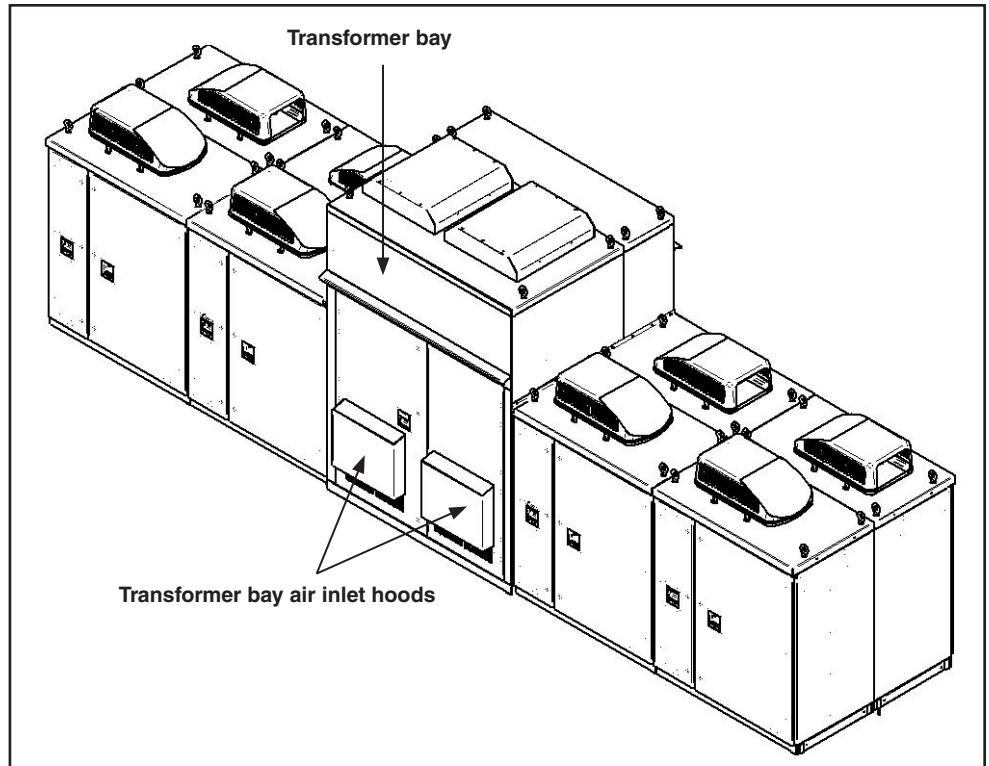

Figure 2. Rear view of a PureWave UPS System enclosure, showing the transformer bay air inlet hoods.

As shown in Figure 1 on page 10 and Figure 2, the enclosure consists of the following bays:

- Battery bay
- Control bay
- Transformer bay

Battery bay - Each battery bay contains a 250-kW battery module and a power conversion module (PCM) section. The PCM section contains the PCM, which is comprised of one inverter module consisting of power-conversion electronics and controls. The PCM is panel-mounted and supported by a welded and bolted steel structural base. See Figure 3 below for a view of the battery bay.

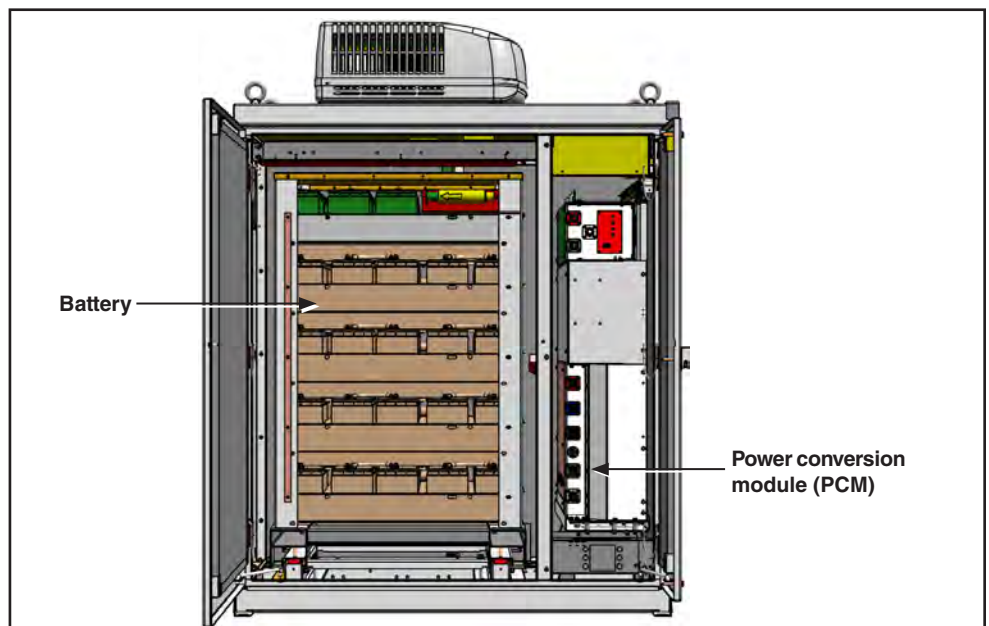

Figure 3. View of the battery bay (with the door open).

NOTICE

The battery bay in Figure 3 on page 11 shows the PCM section on the right side and the battery module on the left side of the bay. These are right-hand battery bays. At the rear of the enclosure, the PCM section and battery module configurations are reversed, where the PCM is on the left side and the battery module is on the right side of the bay. These are left-hand battery bays.

Control bay - The control bay houses the control system and ac filter capacitor section. In addition, an ENABLE/DISABLE keylock is integrated into the control bay door. Inside of the control bay is a control panel which has a RESET pushbutton, an HVAC TEST pushbutton, and a CPC connector. See Figure 4 below for a view of the control bay.

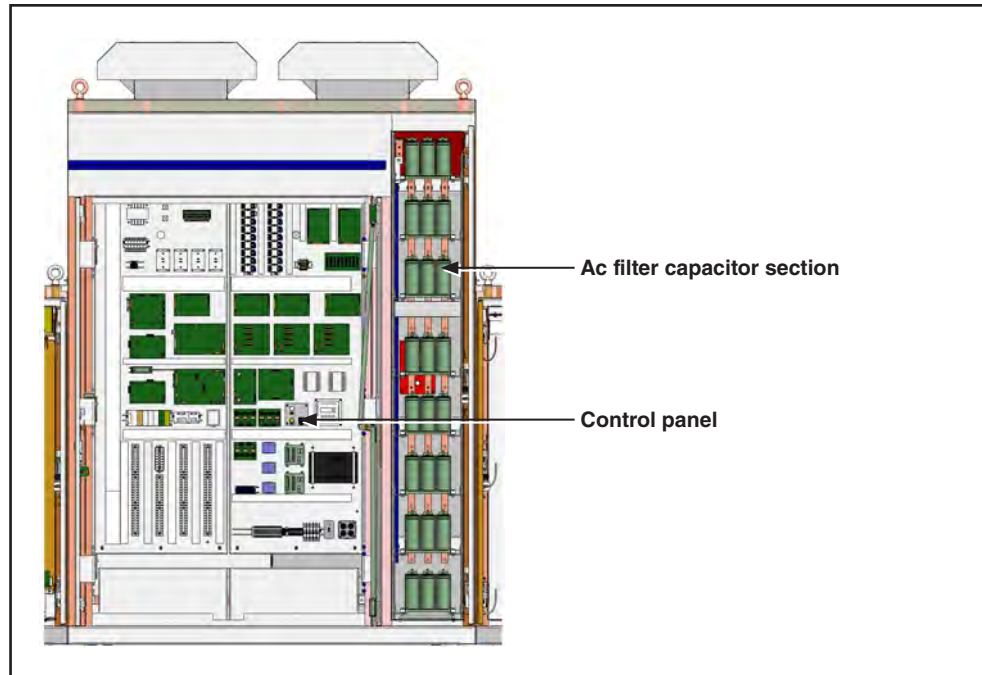

Figure 4. View of the control bay (with the doors open).

Transformer bay - The transformer bay, which is located at the rear of the enclosure, houses the isolation transformer used to match the voltage of the critical load once the energy from the system batteries is converted to ac. See Figure 5 for a view of the transformer bay.

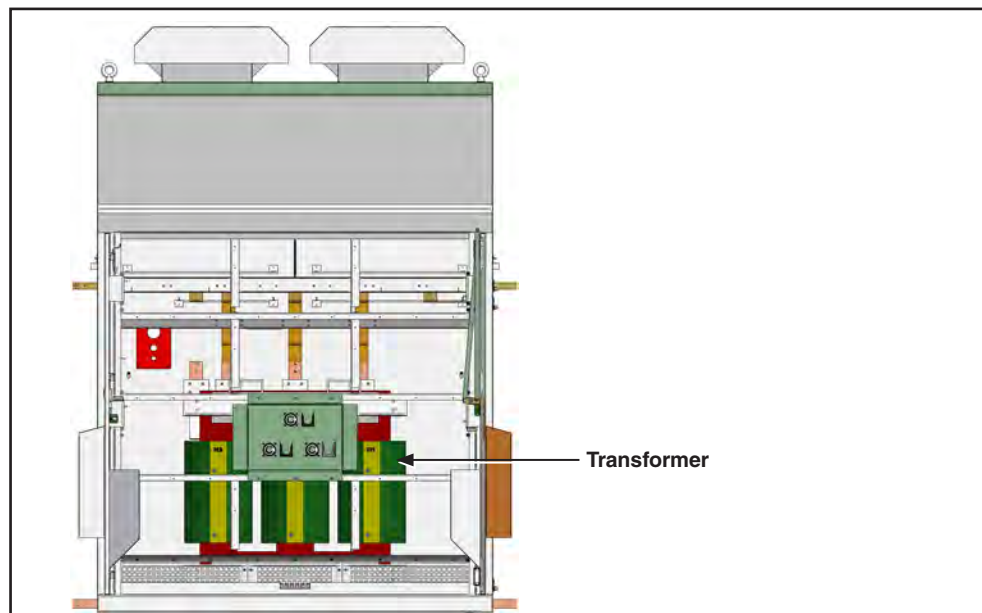

Figure 5. View of the transformer bay (with the door open).

Doors

To open a bay door, remove the padlock from the security hasp and pull the door handle. Once the door is opened approximately 90 degrees or 135 degrees, engage the lock-bar at the bottom of the door to prevent the door from accidentally closing. See Figure 6.



Figure 6. Lock bar at the bottom of a bay door.

To close a door, disengage the lock-bar by lifting the lock-bar and returning it to its storage location. Swing the door closed and secure the door handle.

NOTICE

To open the control bay door, the ENABLE/DISABLE keylock needs to be unlocked, which would result in disabling the system.

Air Control and Ventilation

Components such as air conditioners and air-inlet and -outlet vent/vent hoods are used to regulate the air inside the enclosure. Periodic maintenance is required to ensure the air conditioners, air-inlet filter, vents, and hoods are clear of debris or obstructions that can restrict air flowing in and out of the PureWave UPS System enclosure. Refer to the maintenance instruction sheet for detailed instructions for proper air ventilation maintenance.

Operating Controls

CAUTION

Access and operation of the controls should be performed by authorized personnel who have been trained in using and servicing the PureWave UPS System. Failure to do so can result in damage to the equipment.

Operating controls are located on the control bay door and inside the control bay. The ENABLE/DISABLE keylock is on the control bay door. Inside the control bay (on the control panel) are the following service controls: RESET, HVAC TEST, and CPC (connection).

ENABLE/DISABLE – This keylock is located on and integrated with the control bay door. The lock must be unlocked to open the control bay door. When unlocked, the system is disabled. When the door is closed and locked, the system is enabled.

RESET – This pushbutton allows the operator to manually reset the system alarm(s). When the system is in the **Bypass** state and the RESET pushbutton is pushed, all latched alarm(s) will be reset if the alarm(s) have cleared.

HVAC TEST – This pushbutton allows authorized service personnel to perform periodic maintenance testing of the heating, ventilation, and air conditioning systems of the PureWave UPS System enclosure.

CPC – This connector allows authorized service personnel to connect to the PureWave UPS System for testing purposes.

Monitoring Computer

The monitoring computer is used to monitor the PureWave UPS System by logging events, displaying active alarms and real-time parameter measurements. The computer is typically installed in one of the power electronic switch (PES) lineup bays.

System Operation

Under normal conditions, power is supplied from the utility grid to the critical load through the input circuit breaker, PES, and output isolation circuit breaker.

The system's utility disturbance monitor (UDM) continuously monitors the supply voltage for a disturbance activity. When a disturbance occurs, the PureWave UPS System turns on the system's high-power inverter(s). The stored energy in the system's batteries is converted to ac and supplied through a voltage-matching isolation transformer while the PES is commanded off (open) to isolate the customer's critical loads from the faulted utility. Output power matches the customer load for one minute at full load (or up to three minutes at reduced power) during the utility voltage disturbance or momentary power interruption.

The entire transfer sequence occurs typically within 1 to 4 milliseconds (less than ¼ cycle). An electrically operated bypass circuit breaker permits continued service to the customer from the utility in the event the PureWave UPS System is out of service for maintenance. See Figure 7 for a diagram of the PureWave UPS System.

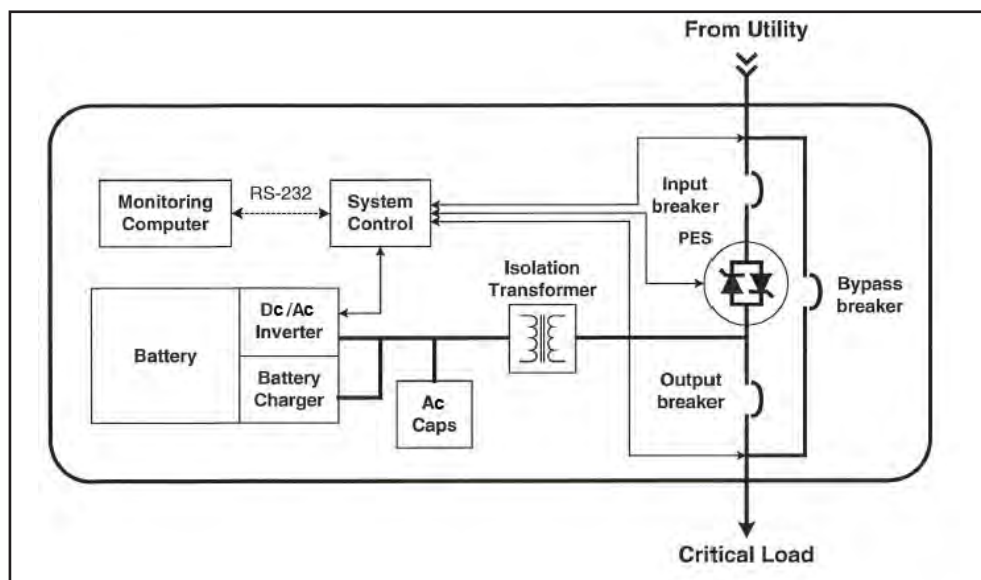

Figure 7. Diagram of the PureWave UPS System.

States

Listed in Table 1 are the states of the PureWave UPS System. Depending on the alarm condition encountered, the system can be in any of these states. The user interface shall inform the user the state that the system is currently in. Below is the list and description of each state.

Table 1. Operating States for the PureWave UPS System.

States	Description
Ready	In this state, the PureWave UPS System is ready to protect the load in the event of a disturbance.
Run	In this state, the PureWave UPS System is running to protect the load from a utility disturbance. The inverters are on, and the PES is open.
Inhibit	In this state, the PureWave UPS System has been inhibited from running; however, the load is being fed through the PES. The bypass circuit remains open.
Bypass	In this state, the bypass circuit breaker has been closed; however, the input and output circuit breakers remain closed.
Bypass Isolate	In this state, the bypass circuit breaker is closed, and the input and output circuit breakers are open.
Test in Bypass	This state is used during the startup of the PureWave UPS System or during service. This state permits the system to perform runs while the load is being fed from the utility through the bypass circuit breaker. In this state, the bypass circuit breaker is closed, and the output circuit breaker is open.

Transition States

Listed in Table 2 are the transition states of the PureWave UPS System. These temporary states occur while the PureWave UPS control logic is transitioning from one primary state to another primary state. Primary states are listed in Table 1.

Table 2. Transition states of the PureWave UPS System.

States	Description
Reset	This state is used to reset PureWave UPS System alarms.
Force Off PES	This state is used to command the PES off. The PES remains off for the duration of the Run state, keeping the load isolated from the utility.
Close Mechanical Bypass	This state occurs as the PureWave UPS System is going to the Bypass state. During this transition state, the controls are commanding the bypass circuit breaker closed before transitioning to the Bypass state.
Soft Transfer	The PureWave UPS System enters this state at the end of a Run state. In this state, the load is being transferred to the utility or an optional generator to gradually prevent a voltage or frequency drop that could potentially affect the load.
Load Decelerate	This state is an optional state that will disconnect the load from the utility if the PureWave UPS System cannot run (because of discharged batteries or from a UPS malfunction) and if the load is not in phase with the utility. The purpose of this state is to prevent spinning loads (motors) from being damaged by transferring them from the PureWave UPS System to the utility when the UPS output voltage is not in phase with the utility voltage. The loads will be permitted to decelerate before being re-energized.

Contacts

The following alarm contacts are available as standard for the PureWave UPS System and can be used to activate a customer supplied device:

System Warning: The **System Warning** contact will annunciate upon any warning alarm. Warning alarms indicate a condition that requires attention. However, the Pure Wave UPS System remains in the **Ready** state protecting the load from power disturbances.

System Fault: The **System Fault** contact will annunciate upon any alarm that will place the PureWave UPS System in the **Inhibit** state, **Bypass** state, or **Bypass Isolate** state. System faults indicate a condition that requires attention and that the PureWave UPS System is not protecting the critical load from power disturbances.

The following optional contacts are available. The contacts operate as follows, if provided:

Low Battery: The **Low-Battery** contact will annunciate during a PureWave UPS System run after 50% of its run-time has been used. The contact will annunciate at 30 seconds during a run at full-load.

Load Overcurrent: The **Load Overcurrent** contact will annunciate an alarm when the load current exceeds 115% of the current rating the PureWave UPS System is capable of providing.

UPS Running: The UPS Running contact will annunciate when the PureWave UPS System is in the **Run** state.

Remote Disable (Optional)

If supplied, a normally closed input contact must be provided by the user to the PureWave UPS System. Upon opening of the input contact, the system will go to the **Bypass** state and an output contact will close to indicate the system has been remotely disabled.

Operating Modes and Procedures

The following procedures can be used to operate the PureWave UPS System

WARNING

The following procedures should be followed by authorized personnel who are trained in operating the PureWave UPS System. Failure to do so can result in injury or equipment damage.

Maintenance Bypass Procedure

The following procedures can be used to put the PureWave UPS System into the **Bypass** state:

STEP 1. Disable the PureWave UPS system by unlocking the ENABLED/DISABLE selector keylock, located on the control bay door.

NOTICE

When the keylock is unlocked to the **Disabled** position, the bypass circuit breaker will automatically close and, after a short time delay, the output and input circuit breakers will open.

STEP 2. Verify the PureWave UPS System's input and output circuit breakers are open and that the bypass circuit breaker is closed. If the bypass circuit breaker did not close and the input and output circuit breakers did not open, follow the "System Emergency Bypass Isolation Procedure" below.

Returning the PureWave UPS System to the Ready State

The following procedure provides the means for returning the PureWave UPS System to the **Ready** state from the **Bypass** state.

STEP 1. Verify the input and output circuit breakers are open and the bypass circuit breaker is closed.

STEP 2. Re-enable the UPS by locking the ENABLE/DISABLE selector keylock.

STEP 3. Reset the PureWave UPS System using the monitoring software, if necessary.

System Emergency Bypass Isolation Procedure

In the event that the bypass circuit breaker does not close and the input and output circuit breakers do not open after the maintenance bypass procedure has been implemented, the PureWave UPS System can be placed in the **Bypass** state manually by using the following procedure:

STEP 1. Ensure the ENABLE/DISABLE selector keylock is unlocked (in the **Disabled** position).

STEP 2. Manually close the bypass circuit breaker and isolate any external controls.

The PureWave UPS System may be manually isolated from the utility and load using the following procedure:

STEP 3. Manually open the input and output circuit breakers and isolate any external controls.

NOTICE

If further assistance is needed with the above system emergency bypass isolation procedures, please contact S&C Electric Company.

Battery Charging Modes

Two battery charging modes ensure the batteries are kept in proper working condition. Once a charge cycle of any type begins, the only normal operating mode that can interrupt it is a **Run** event.

Automatic Charge: The PureWave UPS System uses an automatic charging method to ensure the system is ready to handle any power disturbances. Battery modules are charged immediately following a disturbance event. The duration of the charge is directly related to the magnitude and duration of the event. The batteries are charged for two minutes for each second of discharge at full load. The battery charger will remain on for one hour after the batteries are charged.

Equalize Charge: A complete equalization charge cycle will be automatically performed every two months. Equalize charging is a battery conditioning function that ensures top performance of the batteries.

Besides the charging modes above, the battery modules may be manually charged. Manual charging may be required if the PureWave UPS System is not commissioned within 60 days of shipment or if the PureWave UPS System is in the **Bypass** state for more than 60 days. Contact S&C if manual charging is required.

Generator Interface

As an option and if provided, the PureWave UPS System control can be electrically connected to the transfer switch via a dry contact. Actuating the contact (transfer signal) commands the transfer switch to start the generator and transfer to the generator (after the generator is at rated voltage and frequency). The PureWave UPS System will actuate the transfer signal after the system has been running for 5 to 10 seconds (5 seconds at full load, 10 seconds at half-load or less).

Following is a sequence of events listing the events that occur during an outage of more than 5 seconds (assuming full load):

- STEP 1.** Upon a voltage disturbance, the PureWave UPS System goes into the **Run** state.
- STEP 2.** After 5 seconds, the PureWave UPS System actuates the transfer signal to the transfer switch.
- STEP 3.** The transfer switch sends a start signal to the generator.
- STEP 4.** After the generator is at the rated voltage and frequency (as determined by the transfer switch), the transfer switch transfers to the generator.
- STEP 5.** The PureWave UPS System "soft" loads the generator.
- STEP 6.** After the generator accepts the load, the PureWave UPS System returns to the **Ready** state.
- STEP 7.** The PureWave UPS System maintains the transfer signal to the transfer switch until the batteries have charged. After the batteries have charged, the Pure Wave UPS System will de-actuate the transfer signal.
- STEP 8.** The transfer switch will transfer the load back to the utility after the utility voltage is restored and all applicable time delays have timed out.
- STEP 9.** The PureWave UPS System will go into the **Run** state while the transfer switch returns the critical load to the utility.

If the load is at 50% or less of the PureWave UPS System rating, the system will wait for 10 seconds before actuating the transfer signal.

Alarms List and Troubleshooting Tips

The PureWave UPS System contains an extensive self-diagnosis system. If any abnormal condition occurs, or if the system cannot protect the load from a disturbance, the system will activate an alarm. The alarms can be categorized by alarm type. Alarm types are categorized as **Warning**, **Inhibit**, **Bypass**, and **Bypass Isolate**.

NOTICE
<p>The Troubleshooting tips listed in the following tables are for guidance purposes. Please contact S&C Electric Company if more Troubleshooting assistance is required or if there are any doubts about how to handle an alarm event.</p> <p>Some alarms in the following tables may be masked and will not be available for use. Alarms can also be reconfigured during operation and should be documented accordingly.</p>

Warning Alarms

A Warning alarm indicates a condition that requires attention. The system will remain in the Ready state protecting the load from power disturbances. See Table 3 for the listed warning alarms.

Table 3. Warning alarms.

Warning Alarms	Description
Best Power Circuit Warning	Indicates the backup control power has malfunctioned Troubleshooting Tip: Contact S&C Electric Company.
Broken Thermocouple	Indicates a broken thermocouple inside the system enclosure Troubleshooting Tip: One of the thermocouples that are plugged into the analog interface board on the control panel has been unplugged or is broken. Verify they are plugged in. If so, check the thermocouples for broken connections.
CB Over Current	Indicates the bypass circuit breaker or one of the isolation circuit breakers tripped because of an overcurrent Troubleshooting Tip: After verification and gathering information on the states leading the system to this fault, reset the system and verify the fault clears. If problem persists, contact S&C Electric Company.
Charger Start Alarm	Indicates the charger did not turn on when expected to Troubleshooting Tip: Turn off the dc power to the module. Contact S&C Electric Company.
Container Over Temp	Indicates the temperature inside the system enclosure is over 40°C (104°F) Troubleshooting Tip: The air conditioners may not be working, or they may not be able to keep up with the temperature rise. Check the output block that turns on the contactors and the circuit breakers that feed the air conditioners. The air conditioners may be frozen and need to be de-iced.
Container Under Temp	Indicates the temperature inside the system enclosure is below 5°C (41°F) Troubleshooting Tip: The heater in the air curtain may not be working. Check the output block that turns on the heater and the circuit breaker that feeds the air curtain.
Genset CB Close Alarm	Indicates the generator circuit breaker did not close when expected to Troubleshooting Tip: Contact S&C Electric Company.
Genset CB Open Alarm	Indicates the generator circuit breaker did not open when expected to Troubleshooting Tip: Contact S&C Electric Company.
Genset Start Alarm	Indicates the generator did not start when expected to Troubleshooting Tip: Contact S&C Electric Company.
Input CB Alarm	Indicates the input circuit breaker is open when it should be closed or is closed when it should be open Troubleshooting Tip: Contact S&C Electric Company.
Load Switch Is Open	Indicates the load switch is open Troubleshooting Tip: If the load switch is closed and this alarm is active, contact S&C Electric Company.

Table 3. Warning alarms—continued.

Warning Alarms	Description
Module Fault	Indicates a power module has a condition that renders it unavailable to operate Troubleshooting Tip: A module fault could be an effect and not a cause in most events. Rule out all other causes of the alarm.
Output CB Alarm	Indicates the output circuit breaker is open when it should be closed, or closed when it should be open Troubleshooting Tip: Contact S&C Electric Company.
PES Blower Alarm	Indicates the PES blowers are not running as expected (The system will go to bypass if the temperature has exceeded 104°C (219°F)) Troubleshooting Tip: Contact S&C Electric Company.
PES Blower Warning	Indicates the PES blowers should be running but are moving less air than expected Troubleshooting Tip: Contact S&C Electric Company.
PES Over Temp Warn	Indicates the PES is at 90°C (194°F) or higher Troubleshooting Tip: This could be caused by restricted air flow because of a dirty or obstructed air filter or a blower malfunction. Check these components to ensure they are clean and functioning properly.
PES Over Temperature	Indicates the PES is at 100°C (212°F) or higher Troubleshooting Tip: This could be caused by restricted air flow because of a dirty or obstructed air filter or a blower malfunction. Check these components to ensure they are clean and functioning properly.
Regulator Fault	Indicates the voltage and current regulator circuit board has detected a fault Troubleshooting Tip: Contact S&C Electric Company.
Shorted SCR Warning	Indicates an SCR is shorted Troubleshooting Tip: Contact S&C Electric Company.
Smoke Warning	Indicates a single smoke detector is activated Troubleshooting Tip: Investigate the bays to see if there is a fire.
Test In Bypass Req	Indicates the system has been placed in the Test in Bypass state Troubleshooting Tip: No action is required.
Test Run Request	Indicates a test run of the system was requested Troubleshooting Tip: No action is required.
Time Not Set	Indicates the time is not set in the master control board Troubleshooting Tip: Contact S&C Electric Company.

Table 3. Warning alarms—continued.

Warning Alarms	Description
Transformer Over Temp	Indicates the transformer compartment is at or above 88°C (190°F) Troubleshooting Tip: This could be caused by restricted air flow because of a dirty or obstructed air filter. Check these components to ensure they are clean and functioning properly.
Utility CB Close Alarm	Indicates the utility circuit breaker did not close when expected to Troubleshooting Tip: Contact S&C Electric Company.
Utility CB Open Alarm	Indicates the utility circuit breaker did not open when expected to Troubleshooting Tip: Contact S&C Electric Company.
Utility Over Freq	Indicates the system is sensing a utility frequency greater than 1 Hz above the nominal frequency Troubleshooting Tip: The system will respond based on the over-frequency settings. The frequency threshold can be changed if desired.
Utility Over Voltage	Indicates the system is sensing a utility voltage greater than 110% of the nominal voltage Troubleshooting Tip: The system will respond based on the over-voltage settings. The voltage threshold can be changed if desired.
Utility Under Freq	Indicates the system is sensing a utility frequency greater than 1.5 Hz below the nominal frequency Troubleshooting Tip: The system will respond based on the under-frequency settings. The frequency threshold can be changed if desired.
Utility Undr Voltage	Indicates the system is sensing a utility voltage less than 90% of the nominal voltage Troubleshooting Tip: The system will respond based on the under-voltage settings. The voltage threshold can be changed if desired.

Inhibit Alarms

An **Inhibit** alarm indicates a condition that requires attention and places the system in the **Inhibit** state. The system is not available to protect the load from power disturbances. See Table 4 for the listed Inhibit alarms.

Table 4. Inhibit alarms.

Inhibit Alarm	Description
Battery Discharged	Indicates the batteries are discharged Troubleshooting Tip: Batteries should automatically be charging. If not and the problem persists, contact S&C Electric Company.
Load Over Current	Indicates the load current has exceeded 115% of the current rating of the system Troubleshooting Tip: Check the load against what the PureWave UPS System was sized for.
Load Over Power	Indicates the load power has exceeded 115% of the power rating of the system Troubleshooting Tip: Check the load against what the PureWave UPS System was sized for.
Lost Synch With Util	Indicates the system is not synchronized with the utility Troubleshooting Tip: If the utility voltage, frequency, and phase rotation are good, contact S&C Electric Company. If the voltage, frequency, or phase rotation is bad, the inverter may not be able to lock to the utility until the voltage and frequency are both within tolerance.
Parallel Bd Comm Err	Indicates the parallel board communication is delayed or interrupted Troubleshooting Tip: Contact S&C Electric Company.
Reverse Phase Rotate	Indicates the phase rotation of the utility and/or load conductors is not correct Troubleshooting Tip: Verify the phasing by safely checking the utility connection wires.
UPS Disconnect Open	Indicates the disconnect circuit breaker is open Troubleshooting Tip: If the circuit breaker is closed and this alarm is active, contact S&C Electric Company.

Bypass Alarms

A **Bypass** alarm indicates a condition that requires attention and places the system in the **Bypass** state. The system is not available to protect the load from power disturbances. See Table 5 for the listed bypass alarms.

Table 5. Bypass alarms.

Bypass Alarm	Description
Bypass CB Alarm	Indicates the bypass circuit breaker is open when it should be closed, or closed when it should be open Troubleshooting Tip: Contact S&C Electric Company.
Remote Disable	Indicates the system was disabled remotely Troubleshooting Tip: If the customer did not remotely disable the system, contact S&C Electric Company.
UPS Output Fault	Indicates a fault downstream of the system Troubleshooting Tip: Investigate the distribution system and loads before returning the system to the Ready state.

Bypass Isolate Alarms

A **Bypass Isolate** alarm indicates a condition that requires attention and places the system in the **Bypass Isolate** state. The system is not available to protect the load from a power disturbance. See Table 6 for the listed bypass isolate alarms.

Table 6. Bypass Isolate alarms.

Bypass Isolate Alarm	Description
Fire Hot Temp Zone #	Indicates temperature is over 65°C (149°F) at the designated bay Troubleshooting Tip: There is a fire in the designated zone. Contain the fire and then contact S&C Electric Company.
Fire Hot Temp	Indicates the temperature inside the enclosure has reached 65°C (149°F) Troubleshooting Tip: There is a fire in the container. Contact S&C Electric Company after responding to the fire.
Neutral Res Voltage	Indicates a system neutral or module fault Troubleshooting Tip: Contact S&C Electric Company.
Open PES Alarm	Indicates the PES is expected to close but does not Troubleshooting Tip: The system will automatically reset three times. After the third time, if the PES is still open, contact S&C Electric Company.
Operation Disabled	Indicates the load has been placed in the Bypass Isolate state via the ENABLE/DISABLE toggle switch or the ENABLE/DISABLE pushbutton Troubleshooting Tip: No action is required. However, if the system was not disabled by the switch or pushbutton, contact S&C Electric Company.
Shorted PES Alarm	Indicates the PES is shorted Troubleshooting Tip: Contact S&C Electric Company.
Smoke In Container	Indicates the smoke detector detected smoke Troubleshooting Tip: Investigate to see whether there is a possible fire inside the container. Contact S&C Electric Company after the smoke has cleared.
UPS Disconnect Fuse Open	Indicates the disconnect fuse is open Troubleshooting Tip: If the fuse is not open and this alarm is active, contact S&C Electric Company.

Overview

The PureWave UPS System can be monitored in two ways. The system can be monitored through the computer provided in a PES lineup bay via a local connection and remotely accessed using an Ethernet connection.

Monitoring Software Security

The PureWave UPS System computer can only be accessed by users with the appropriate security clearance. A valid username and password are necessary to access the system information. To access the system remotely, the remote monitoring software is required along with a username and password for authorized access.

NOTICE

Contact S&C Electric Company to obtain the username and password for access to the monitoring program if you forget your username and/or password.

Monitoring Software

After the username and password have been entered, the user will have access to the monitoring software. The home screen is the *System One-Line* screen. The *System One-Line* screen shows the overview of the PureWave UPS System. It displays the power flow path through the system, providing the user with accurate and timely system information.

Icons

Icons on the status screen change according to the state of the system. The icons and the lines connecting the icons change color depending on the state of the object represented by the icon. See Figure 8 to see the icons and their meanings on the *System One-Line* screen.

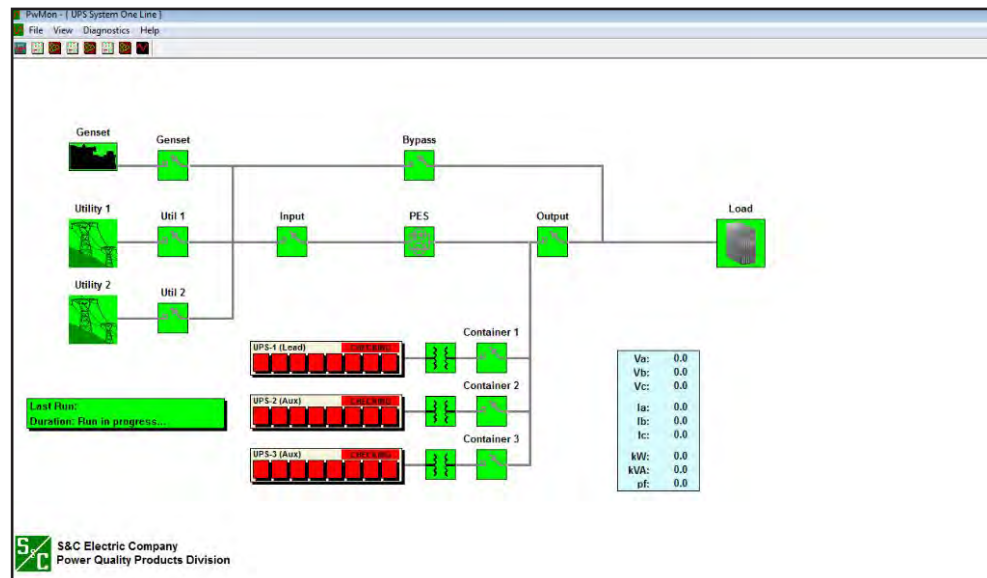

Figure 8. System One-Line screen.

Utility source – If this icon is red, it indicates that the utility is a good source. If the icon is green, it indicates the utility is not good (the source is not within voltage and frequency tolerance).

Power electronic switch (PES) – If this icon is green, the switch is open. If the icon is red, the switch is closed.

Circuit breakers and switches – If these icons are green, the circuit breaker or switch is open. If these icons are red, the circuit breaker or switch is closed.

Load – If this icon is red, the load is being supplied with power. If this icon is green, the load is not being supplied with power.

For power flow, a gray line indicates the power is not flowing through the line. A red line indicates that power is flowing through the line.

At the top-left of the screen are icons that help the user navigate through the monitoring program. See Figure 9.

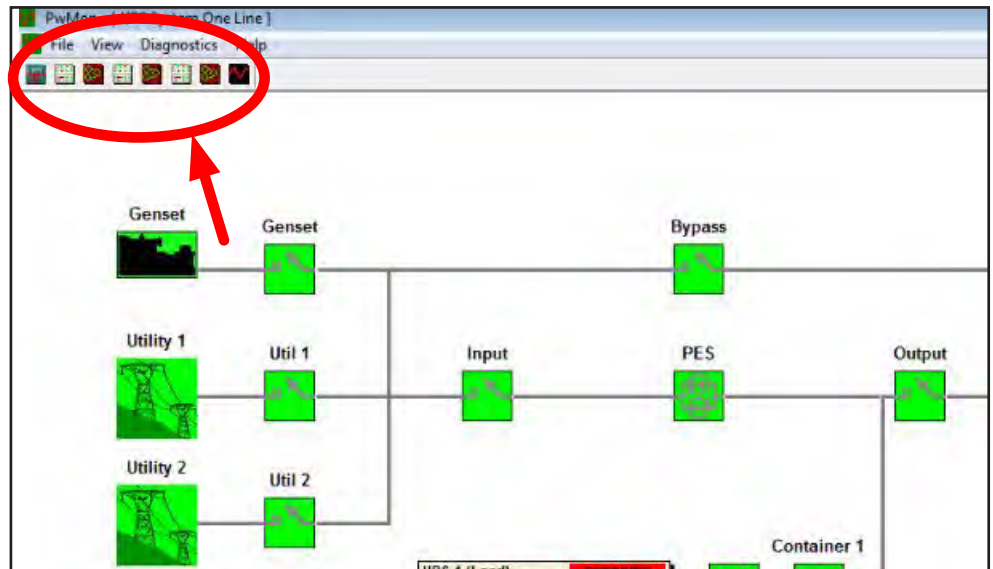

Figure 9. Navigation icons.

The icons provided are as follows:

- *One-line* screen
- *Status* screen
- Snapshot Viewer – For service personnel only
- Event Viewer – For service personnel only

For systems with multiple system enclosures, a *Status* screen and a *Snapshot Viewer* screen are available per enclosure to show the relevant status data.

Displayed Parameters

Figure 10 shows the areas of the One-Line screen where the user can find measured parameters of the PureWave UPS System.

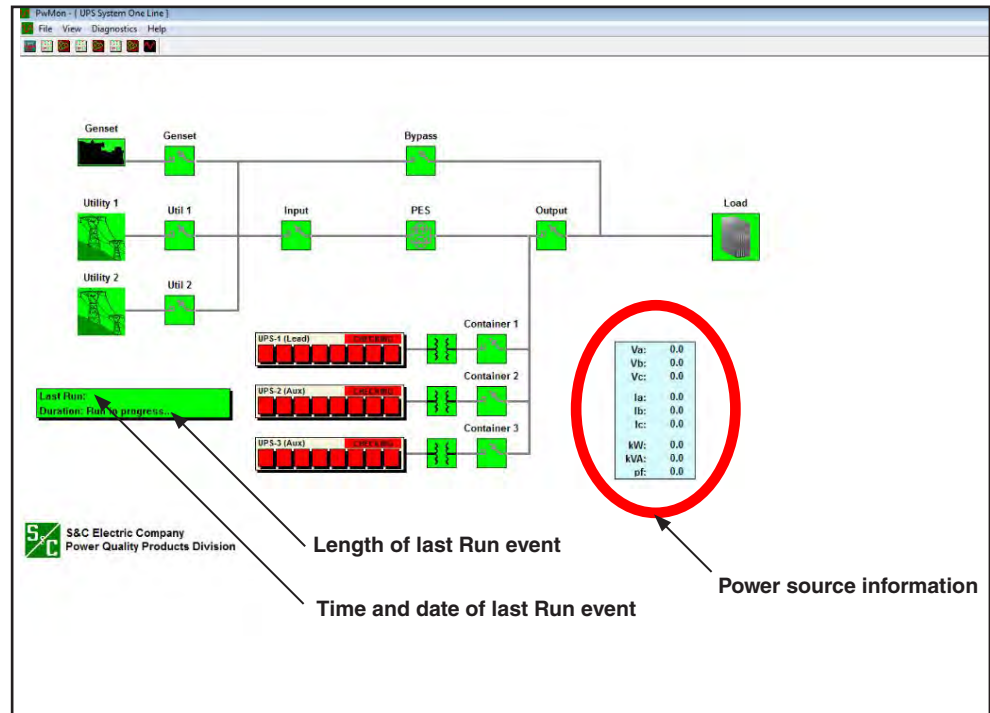

Figure 10. Displayed parameters on the System One-Line screen.

Status Screen

The Status screen shows all the alarms for the PureWave UPS System and displays the active alarms using color indicators. In addition, the screen shows the current, voltage, and other parameters of the system as displayed in Figure 11.

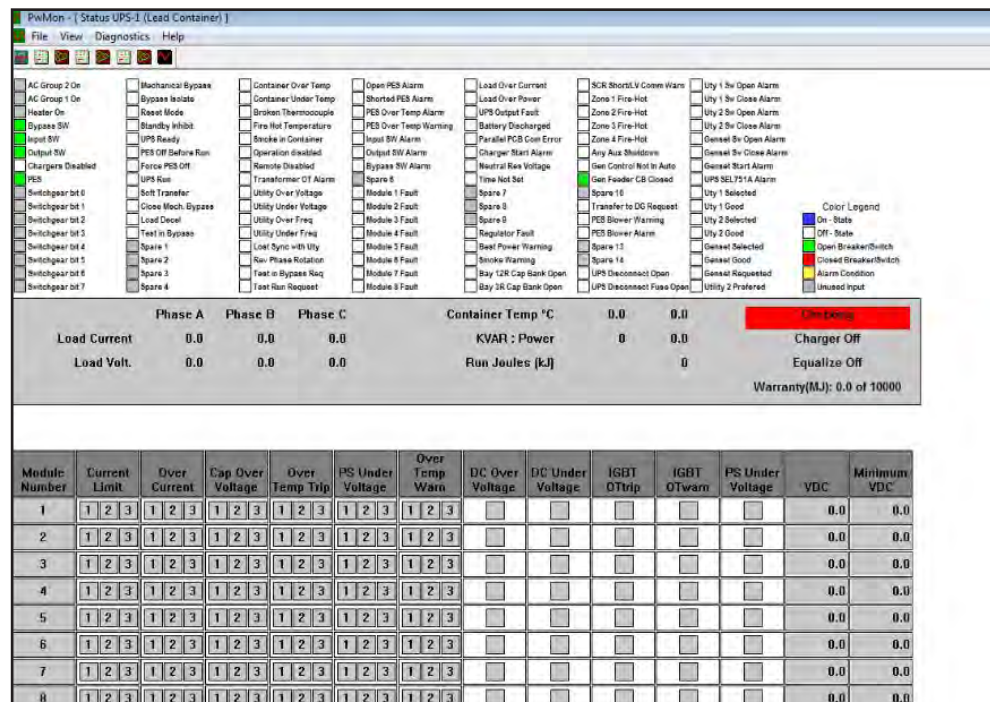

Figure 11. Status screen.

Overview

The following checklist provides the inspection activities that are to be performed on an annual basis for the PureWave UPS System. The amount of dust and dirt varies from site to site. Therefore, schedules for maintenance should be reviewed by the user based on the given site conditions and, if required, the frequency of the recommended maintenance may be increased to ensure the reliability of their PureWave UPS System.

S&C Electric Company has extended service agreements and spare parts kits available for the PureWave UPS System. Please contact S&C Electric Company – Global Support Monitoring Center at (888) 762-1100.

The PureWave UPS System will require maintenance to help ensure high system reliability and efficiency. The following checklists can be used as a reference to assist in properly maintaining the system.

Quarterly Maintenance

DANGER

Refer to the battery, circuit breaker, and metal-clad switchgear manufacturer maintenance documents to ensure proper maintenance and protection against serious injury or even death.

Proper personal protective equipment (PPE) must be used.

Preparation

- Review the steps in this procedure to prepare the proper tools and test equipment that will be needed to complete the tasks.
- Bring site-specific schematics and familiarize yourself with when and how you will isolate the circuits during the maintenance.
- Coordinate with the site facilitator to obtain keys for locks (if applicable) to unlock the doors to the PureWave UPS System enclosure(s).
- Confirm with the site facilitator that the PureWave UPS System is de-energized prior to conducting maintenance on the system.

Verified By: _____ Date: _____

Required Tools

- Shop vacuum
- Rags or paper towels
- General purpose cleaner (e.g. Simple Green)
- Personal protective equipment
- Standard insulated hand tools (wrench and flat-head screwdriver)
- DAP concrete sealant
- PureWave UPS enclosure touch-up paint

Verified By: _____ Date: _____

Arrival

- Jobsite name:
- Discuss maintenance plan with the local jobsite facilitator.

Record the following information:

- System state: _____
- List any active alarms: _____

Verified By: _____ Date: _____

⚠ DANGER

The PureWave UPS System must be disabled, placed in the **Bypass Isolate** state, and de-energized before performing maintenance on the equipment. Failure to do so can result in serious injury or even death.

Maintenance should only be conducted by S&C Electric Company personnel or personnel who are properly trained by S&C Electric Company.

Follow these steps for each PureWave UPS System enclosure:

- Enclosure #: _____
- Visually inspect the outside of the enclosure for signs of deterioration or rust.
- Rust found? **YES** or **NO** (circle one)
 - If yes, clean the rust and paint using the correct paint color for the enclosure.
 - If deterioration or rust is found, but not cleaned and painted, why?

-
- Inspect the enclosure doors. Verify the door seals are intact by closing each door.
 - Inspect the seals between the enclosure and concrete. Reseal any cracks with DAP concrete sealant.

Verified By: _____ Date: _____

Follow these steps for each PureWave UPS System enclosure battery bay:

- Enclosure #: _____ Battery Bay #: _____
- Inspect the top and bottom hydrogen vents located along the inside wall of the bay. Clean any debris or obstructions that can restrict air flow. See Figure A for the location of the hydrogen vents.

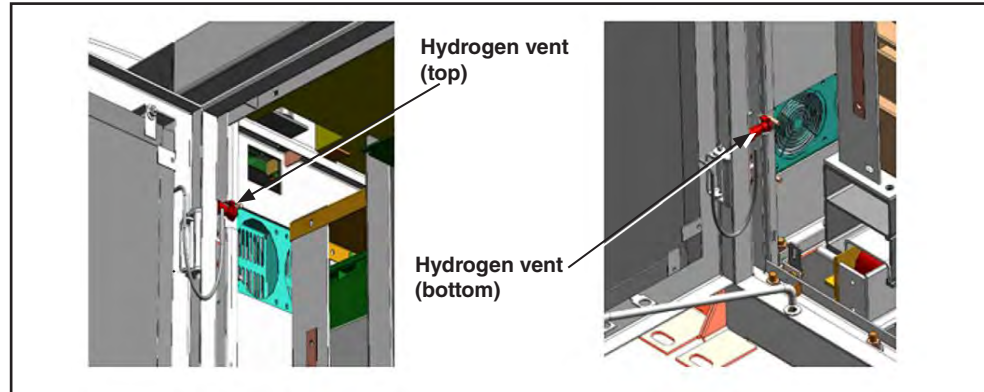

Figure A. Location of the hydrogen vents in the battery bay.

Inspect the air conditioners at the top of the battery bay. Clean any debris or obstructions that can restrict air flow. See Figure B for the location of the air conditioners.

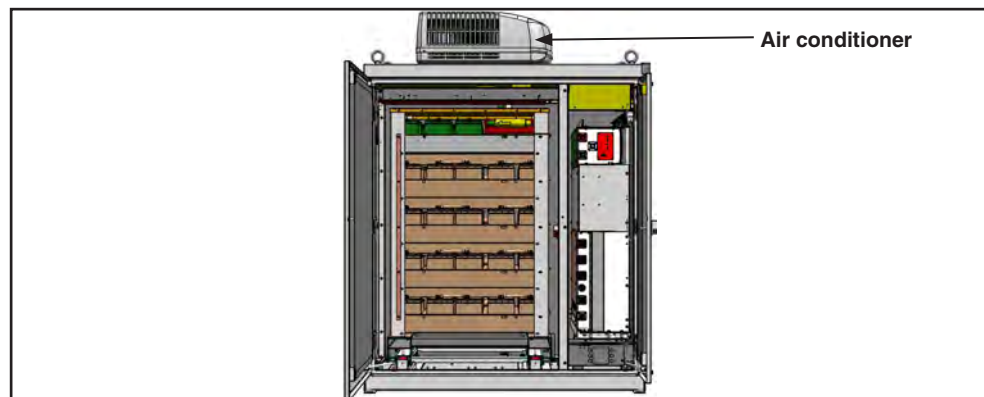

Figure B. Location of an air conditioner on top of the battery bay.

- Inspect the general interior of the bay and verify the bay is clean. Use a vacuum cleaner to perform general cleaning, if necessary.

Verified By: _____ **Date:** _____

Follow these steps for each PureWave UPS System enclosure control bay:

- Enclosure #: _____
- Inspect the general interior of the bay and verify the bay is clean. Use a vacuum cleaner to perform general cleaning, if necessary.

Verified By: _____ Date: _____

Follow these steps for each PureWave UPS System enclosure transformer bay:

- Enclosure #: _____
- Inspect the transformer air-inlet vents located on the doors of the bay. Clean any debris or obstructions that can restrict air flow.

Verified By: _____ Date: _____

Follow these steps for the PureWave UPS System PES lineup:

- Visually inspect the outside of the enclosure for signs of deterioration or rust.
- Rust found? **YES** or **NO** (circle one)
 - If yes, clean the rust and paint using the correct paint color for the enclosure.
 - If deterioration or rust is found, but not cleaned and painted, why?

- Inspect the enclosure doors. Verify the door seals are intact by closing each door.
- Inspect the seals between the enclosure and concrete. Reseal any cracks with DAP concrete sealant.
- Clean inside the bay containing the monitoring computer using paper towels and/or vacuum cleaner.
- Inspect the monitoring computer to ensure it is operating properly and displaying the proper information.

Verified By: _____ Date: _____

Maintenance

Departure

- Perform general housekeeping, ensuring there is no garbage or debris in or around each system enclosure, the PES lineup, and metal-clad switchgear.
- Bring the PureWave UPS System back online.
- Record the system state: _____
- Close and lock all the enclosure doors and return site keys to the facility supervisor (if applicable).

Notes:

Verified By: _____ **Date:** _____

Annual Maintenance

DANGER

The PureWave UPS System must be disabled, placed in the **Bypass Isolate** state, and de-energized before performing maintenance on the equipment. Failure to do so can result in serious injury or even death.

Maintenance should only be conducted by S&C Electric Company personnel or personnel who are properly trained by S&C Electric Company.

Preparation

- Review the steps in this procedure to prepare the proper tools and test equipment that will be needed to complete the tasks.
- Bring site-specific schematics and familiarize yourself with when and how you will isolate the circuits during the maintenance.
- Coordinate with the site facilitator to obtain keys for locks (if applicable) to unlock the doors to the PureWave UPS System enclosure(s).
- Confirm with the site facilitator that the PureWave UPS System is de-energized.

Verified By: _____ Date: _____

Required Tools

- Shop vacuum
- Rags or paper towels
- General purpose cleaner (e.g. Simple Green)
- Personal protective equipment
- Insulated torque wrench
- Standard assorted insulated hand tools (wrench, flat-head screwdriver, etc.)
- DAP concrete sealant
- PureWave UPS enclosure touch-up paint
- Lock-out/Tag-out tags and locks
- Calibrated Hioki 16 Channel Digital Waveform Recorder or oscilloscope
- Two calibrated Fluke 87 digital multimeters

Verified By: _____ Date: _____

Arrival

- Jobsite name:
- Discuss maintenance plan with the local jobsite facilitator.

Record the following information:

- System state: _____
- List any active alarms: _____

Verified By: _____ Date: _____

⚠ DANGER

The PureWave UPS System must be disabled, placed in the **Bypass Isolate** state, and de-energized before performing maintenance on the equipment. Failure to do so can result in serious injury or even death.

Maintenance should only be conducted by S&C Electric Company personnel or personnel who are properly trained by S&C Electric Company.

Follow these steps for each PureWave UPS System enclosure:

- Enclosure #: _____
- Visually inspect the outside of the enclosure for signs of deterioration or rust.
- Rust found? **YES** or **NO** (circle one)
 - If yes, clean the rust and paint using the correct paint color for the enclosure.
 - If deterioration or rust is found, but not cleaned and painted, why?

- Inspect the interior of the enclosure bays and verify there are no signs of water ingress.
- Inspect the enclosure doors. Verify the door seals are intact by closing each door.
- Inspect the seals between the enclosure and concrete. Reseal any cracks with DAP concrete sealant.
- Verify ground connections are firmly in place.
- Verify all affixed labeling is legible and in place.
- Verify all hardware connections are tight.

Verified By: _____

Date: _____

Follow these steps for each PureWave UPS System enclosure battery bay:

- Enclosure #: _____ Battery Bay #: _____
- Inspect the top and bottom hydrogen vents located along the inside wall of the bay. Clean any debris or obstructions that can restrict air flow. See Figure A for the location of the hydrogen vents.

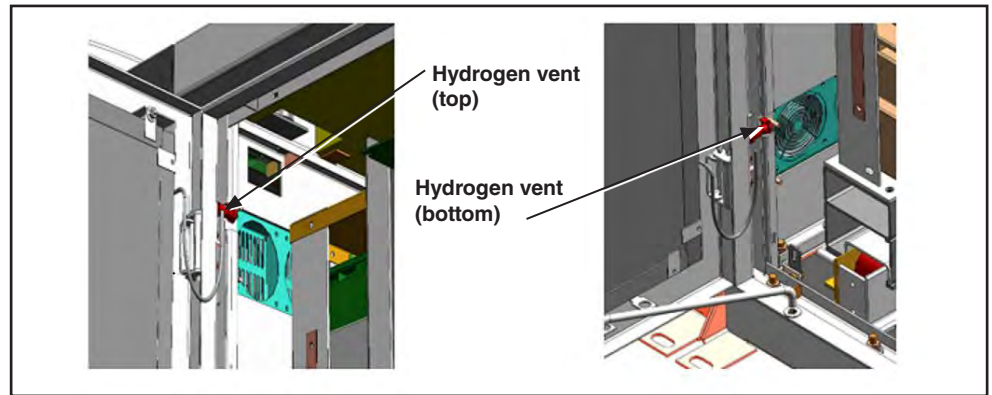

Figure A. Location of the hydrogen vents in the battery bay.

In the PCM section, verify the following:

- Camlok connections are clean and firmly in place.
- Control connections are clean and firmly in place.
- Fiber optic connections are clean and firmly in place.
- Hydrogen vent tubes for batteries are clean and firmly in place.
- Inspect the air conditioners at the top of the battery bay. Clean any debris or obstructions that can restrict air flow. See Figure B for the location of the air conditioners.

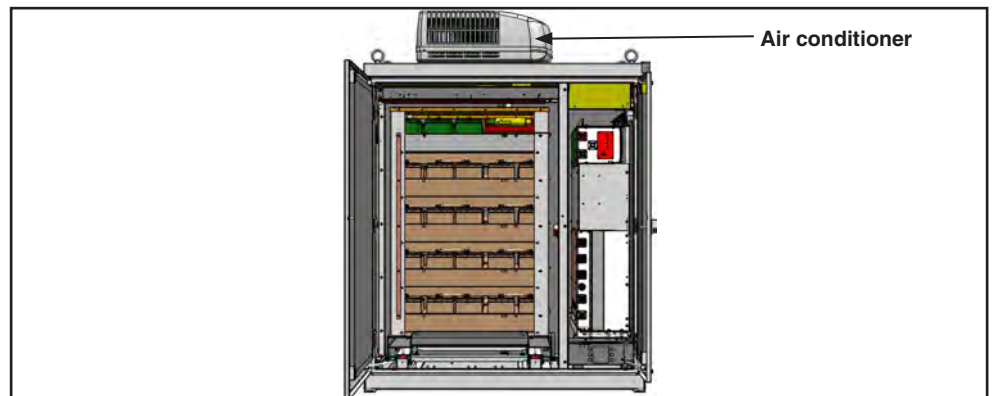

Figure B. Location of an air conditioner on top of the battery bay.

- Inspect the battery bay hold-down bolts. Clean and re-tap threads, if required.
- Inspect the general interior of the bay and verify the bay is clean. Use a vacuum cleaner to perform general cleaning, if necessary.

Verified By: _____ Date: _____

Follow these steps for each PureWave UPS System enclosure control bay:

- Enclosure #: _____
- Inspect the general interior of the bay and verify the bay is clean. Use a vacuum cleaner to perform general cleaning, if necessary.
- Verify tightness of all wire terminations.

Verified By: _____ Date: _____

Follow these steps for each PureWave UPS System enclosure transformer bay:

- Enclosure #: _____
- De-energize and apply the lockout/tagout procedure to the transformer.
- Apply the safety grounds to the transformer.

⚠ CAUTION

Do not use liquid cleaners when cleaning inside the transformer bay. The chemicals may damage the insulating materials.

- Verify the bay is clean and free of dirt (especially accumulations of the coil). If the coil is dirty, use a vacuum cleaner to clean it.
- Transformer lead supports, terminal boards, and other major insulating surfaces should be wiped clean with a clean cloth.
- Inspect the transformer air inlet vents located on the doors of the bay. Clean any debris or obstructions that can restrict air flow.
- After cleaning and inspection, remove the safety grounds.
- Remove the lockout/tagout and re-energize the transformer.

Verified By: _____

Date: _____

Follow these steps for the PureWave UPS System PES and lineup:

- Decouple the input and output operators.
- Use the key-flow procedure (if applicable) to ground the PES.
- Visually inspect the outside of the enclosure for signs of deterioration or rust.
- Rust found? **YES** or **NO** (circle one)
 - If yes, clean the rust and paint using the correct paint color for the enclosure.
 - If deterioration or rust is found, but not cleaned and painted, why?

- Inspect the enclosure doors. Verify the door seals are intact by closing each door.
- Inspect the seals between the enclosure and concrete. Reseal any cracks with DAP concrete sealant.
- Clean inside the bay containing the monitoring computer using paper towels and/or vacuum cleaner.
- Inspect the monitoring computer to ensure it is operating properly and displaying the proper information.
- Open the PES door and verify there is no power present.
- Measure the resistance (in both directions) for each module within the PES. Record the findings in the table below:

Stage	A Phase		B Phase		C Phase	
	Positive	Negative	Positive	Negative	Positive	Negative
1						
2						
3						
4						
5						
6						
7						
8						
9						

- Verify the snubber capacitors (1 uF) and snubber resistors (100 ohms) are good.
- Verify the 10000-ohm resistor behind the high voltage gate boards are good.
- Check all hardware to verify tightness.
- Inspect the PES blower dampers and verify they operate freely and do not bind.
- Use the key-flow procedure (if applicable) to ground the PES.
- Couple the input and output operators.

Verified By: _____ Date: _____

NOTICE
Contact S&C Electric Company to conduct calibration verification and operational testing services.

⚠ WARNING

The following procedures require the PureWave UPS System to have utility power. The system should be placed in the **Bypass Isolate** state prior to conducting the proceeding equipment testing procedures. Failure to do so can result in personal injury or equipment damage.

Equipment Testing

- Verify all smoke detectors are available, undamaged and operate when tested.
- Enable the system and verify the air conditioners are working properly by measuring and recording the compressor current draw on each A/C unit with an Ammeter after the A/C unit is running for 2 minutes. Operate the A/C unit by either pushing in the A/C contactor in the bay being tested or by applying a jumper at the HVAC PLC. The current should be between 10 and 15 amps. Record these measurements in Table A below.
- Hold your hand under each of the air conditioners to verify cool air is still being produced.
- Record the ambient temperature below when air conditioner testing is being performed. Replace the switchable output blocks with the original output blocks after verification (if used).

Ambient Temperature: _____

Enclosure #: _____

Battery Bay	Compressor Current Draw (Amperes)
1	
2	
3	
4	
5	
6	
7	
8	

Table A. Air conditioners testing data.

NOTICE

If the air conditioners are not providing proper cooling of the batteries, the condition can reduce the life of the batteries. Overheating of the batteries could void any warranty because of lack of proper maintenance of the PureWave UPS System enclosure. Contact S&C Electric Company if air conditioner malfunction is suspected.

- To verify the heaters are working properly, check each heater to verify they are still putting out heat. Operate the heaters by either jumping around the relay in the bay being tested or by applying a jumper at the HVAC PLC.
- Verify the container temperature sensing via monitoring computer.
- Remove a thermocouple from the analog board and verify there is a broken thermocouple warning on the monitoring computer and on the LCD.
- Verify (visually) the control relays are not damaged.
- Verify all fuses are in working order on the control panel.
- Verify the service outlets and lights are operational.

Verified By: _____ **Date:** _____

Departure

- Perform general housekeeping, ensuring there is no garbage or debris in or around each system enclosure, the PES lineup, and metal-clad switchgear.
- Bring the PureWave UPS System back online.
- Record the system state: _____
- Close and lock all the enclosure doors and return site keys to the facility supervisor (if applicable).

Verified By: _____ **Date:** _____