

Network Evaluation Guide

Table of Contents

Section	Page
Introduction	
Qualified Persons	2
Read this Instruction Sheet	2
Retain this Instruction Sheet	2
Proper Application	2
Special Warranty Provisions	2
Safety Information	
Understanding Safety-Alert Messages	3
Following Safety Instructions	3
Replacement Instructions and Labels	3
Overview	4
Test Demonstrations	5
SpeedNet Configuration	
Factory Configuration	6
Radio Setup	6
Basic Network Configuration	11
Build a Two-Node Network	14

Section	Page
Single Link Testing	
Testing with a 32-Byte Payload	18
Testing with a 300-Byte Payload	18
Testing Bandwidth with Iperf	19
Building a Three-Node Network	21
Testing Route Discovery	25
Building a Four-Node Network	26
Testing Alternate Routing	29
Building a Five-Node Network	31
Point-to-Multipoint Network	34
Testing Route Optimization	37
AODV Gateway	38
Security	39
Serial Mode	40



Introduction

Qualified Persons

 WARNING
<p>The equipment covered by this publication must be installed, operated, and maintained by qualified persons who are knowledgeable in the installation, operation, and maintenance of radios in electric power distribution equipment, along with the associated hazards. A qualified person is a radio technician who is qualified to install transmission-power-limited radio equipment per FCC Part 15 and who is trained and competent in:</p> <ul style="list-style-type: none">• The skills and techniques necessary to distinguish exposed live parts from nonlive parts of electrical equipment• The skills and techniques necessary to determine the proper approach distances corresponding to the voltages to which the qualified person will be exposed• The proper use of the special precautionary techniques, personal protective equipment, insulating and shielding materials, and insulated tools for working on or near exposed energized parts of electrical equipment <p>These instructions are intended only for such qualified persons. They are not intended to be a substitute for adequate training and experience in safety procedures for this type of equipment.</p>

Read this Instruction Sheet

NOTICE
<p>Thoroughly and carefully read this instruction sheet before programming, operating, or maintaining your S&C SpeedNet Radios. Familiarize yourself with the Safety Information on page 3. The latest version is available online in PDF format at sandc.com/en/support/product-literature/.</p>

Retain this Instruction Sheet

This instruction sheet should be available for reference wherever SpeedNet Radio is to be used. Retain this instruction sheet in a location where you can easily retrieve and refer to it.

Proper Application

 WARNING
<p>The equipment in this publication must be selected for a specific application. The application must be within the ratings furnished for the selected equipment.</p>

Special Warranty Provisions

The standard warranty contained in the seller's standard conditions of sale, as set forth in Price Sheet 150, applies to S&C SpeedNet Radios, except that the first paragraph of the said warranty is replaced by the following:

(1) General: The seller warrants to the purchaser for a period of two years from the date of shipment that the equipment delivered will be of the kind and quality specified in the contract description and will be free of defects of workmanship and material. Should any failure to conform to this warranty appear under proper and normal use within two years after the date of shipment, the seller agrees, upon prompt notification thereof and confirmation that the equipment has been stored, installed, operated, inspected, and maintained in accordance with the recommendations of the seller and standard industry practice, to correct the nonconformity either by repairing any damaged or defective parts of the equipment or (at the seller's option) by shipment of necessary replacement parts. The above special warranty does not apply to gateway communication devices applied with SpeedNet Radios.

Understanding Safety-Alert Messages

Several types of safety-alert messages may appear throughout this instruction sheet as well as on labels attached to the SpeedNet Radio. Familiarize yourself with these types of messages and the importance of these various signal words:

⚠ DANGER
“DANGER” identifies the most serious and immediate hazards that <i>will</i> likely result in serious personal injury or death if instructions, including recommended precautions, are not followed.

⚠ WARNING
“WARNING” identifies hazards or unsafe practices that <i>can</i> result in serious personal injury or death if instructions, including recommended precautions, are not followed.

⚠ CAUTION
“CAUTION” identifies hazards or unsafe practices that <i>can</i> result in minor personal injury if instructions, including recommended precautions, are not followed.

NOTICE
“NOTICE” identifies important procedures or requirements that <i>can</i> result in product or property damage if instructions are not followed.

Following Safety Instructions

If you do not understand any portion of this instruction sheet and need assistance, contact your nearest S&C Sales Office or S&C Authorized Distributor. Their telephone numbers are listed on S&C’s website sandc.com. Or call S&C Headquarters at (773) 338-1000; in Canada, call S&C Electric Canada Ltd. at (416) 249-9171.

NOTICE	
Read this instruction sheet thoroughly and carefully before installing or operating your S&C SpeedNet Radio.	

Replacement Instructions and Labels

If you need additional copies of this instruction sheet, contact your nearest S&C Sales Office, S&C Authorized Distributor, S&C Headquarters, or S&C Electric Canada Ltd.

It is important that any missing, damaged, or faded labels on the equipment be replaced immediately. Replacement labels are available by contacting your nearest S&C Sales Office, S&C Authorized Distributor, S&C Headquarters, or S&C Electric Canada Ltd.

The SpeedNet Network Evaluation Kit is used to demonstrate SpeedNet capabilities and ease of use. Unlike other radios that are dedicated to a particular network topology (such as point-to-point, point-to-multipoint, or mesh), SpeedNet technology is application-agile so the most suitable topology can be used for a given application such as SCADA, AMI backhaul, or peer-to-peer. Users can set up a small network to explore the dynamics of SpeedNet technology, its configuration simplicity, and robust network reliability.

The Network Evaluation Kit allows a customer to experience superior SpeedNet Radio:

- Latency
- Bandwidth
- Routing discovery
- Route optimization
- Route recovery
- Security
- Over-the-air firmware upgrade

The network evaluation kit includes:

- 5 SpeedNet Radios
- 5 power supplies
- 5 “rubber-duck” antennas
- Ten 30 dB attenuators
- 2 CAT5 Ethernet cables
- 2 laptop PC computers with administrative privileges
 - SpeedNet Client Tool installed
 - Iperf Performance Measurement Tool installed

The customer will supply:

- Large lab area, radios must be separated by 4 meters
- Labels to mark radio configuration (e.g. Post-it® Notes)

To simulate an actual deployment, all radios are shipped with factory default settings. When the first radio has been configured, the other radios are set up over-the-air with a predetermined configuration sequence. The radios must be configured sequentially to avoid IP conflicts, because they share the same factory IP setting. The radios can be configured to demonstrate different network topologies, and the instructions show where to install specific attenuators for creating various network events and demonstrating how SpeedNet Radios adapt to them.

Test Demonstrations

The following SpeedNet network tests are described in these instructions:

- Set up the first radio and change its IP address.
- Establish a two-node network—***point-to-point***
 - Perform single-link latency test with a payload of 32 bytes and 300 bytes
 - Perform a bandwidth test using Iperf
- Establish a three-node network
 - Observe network entry
 - Observe route discovery
 - Perform three-node latency test with a payload of 32 bytes and 300 bytes
 - Perform a bandwidth test using Iperf, check route optimization, and alternate routing
- Establish a four-node network—***mesh***
 - Observe network entry
 - Observe route discovery
 - Route optimization
 - Alternate routing
- Establish a five-node network—***point-to-multi-point***
 - Observe network entry
 - Observe route discovery
 - Route optimization
 - Alternate routing

SpeedNet Configuration

Factory Configuration

The demo radios are shipped with factory default settings:

- Ethernet IP = 192.168.200.1
 - Wireless IP = 192.168.202.1
 - Network ID = 1
- Contact S&C for default credentials.

Radio Setup

Follow these steps to set up your SpeedNet Radio:

- STEP 1.** Access Network Connections on Laptop #1. (*Start>Control Panel>View network status and tasks*)
- STEP 2.** Power up one of the demo radios and label it as Radio #10.
- STEP 3.** Connect Radio #10 and Laptop #1 with a Cat5 cable.
- STEP 4.** Connect the Rubber Duck antenna.
- STEP 5.** Click the Local Area Connection Properties dialog on Laptop #1 and click on the **Properties** button. Scroll and select the **Internet Protocol Version 4 (TCP/IPv4)** option. See Figure 1.

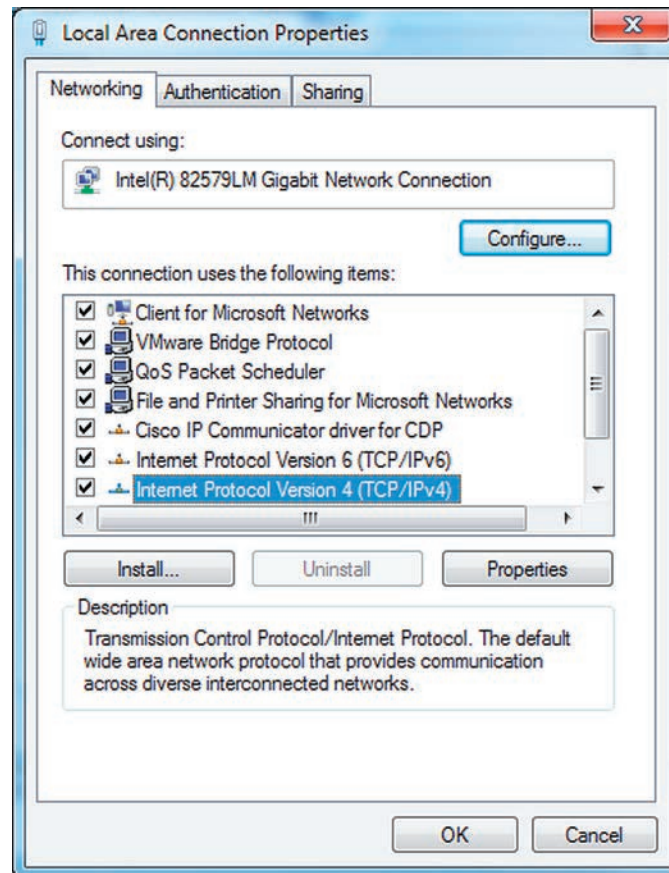

Figure 1. Local Area Connection Properties dialog box.

NOTICE

Laptop firewalls must be disabled for these SpeedNet tests.

Only the Ethernet interface with the radio must be active. All other network interfaces, including WiFi, must be turned off.

STEP 6. Step 6. Click on the **Properties** button. The Internet Protocol Version 4 (TCP/IPv4) Properties dialog box will open. See Figure 2. Select the **Use the Following IP address** option.

STEP 7. Enter the following:

IP address: 192.168.200.50

Subnet Mask: 255.255.255.0

Default Gateway: 192.168.200.1

STEP 8. Click the **OK** button on the Internet Protocol Version 4 (TCP/IPv4) Properties dialog box.

STEP 9. Click the **Close** button on the Local Area Connection Properties dialog box.

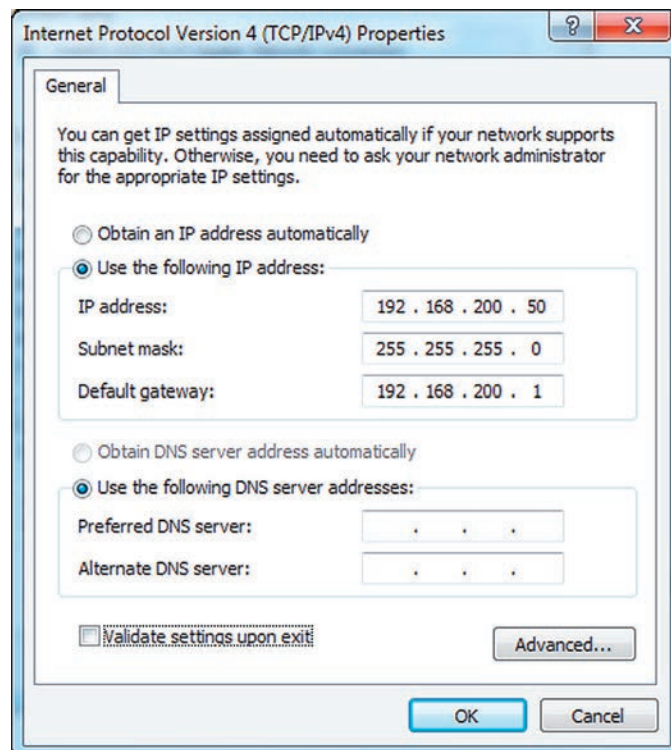

Figure 2. Internet Protocol Version 4 (TCP/IPv4) Properties dialog box.

SpeedNet Configuration

STEP 10. Open the Windows Command Prompt page (*Start>All Programs>Accessories >Command Prompt* screens) and verify connectivity to Radio #10 with this command: **C:\Documents and Settings\>ping 192.168.200.1**

STEP 11. Open the Client Tool (see Figure 3) and enter the following:

IP address: 192.168.200.1

Username: <Default Credentials>

Password: <Default Credentials>

STEP 12. Click the **Login** button.

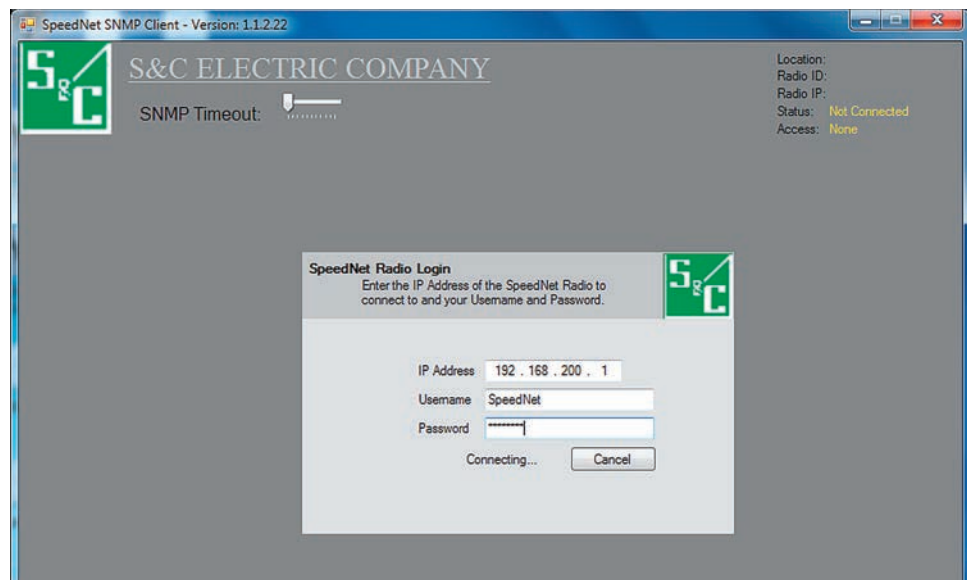

Figure 3. SpeedNet Radio login dialog box.

STEP 13. The **Main** screen will open, as shown in Figure 4. Click on the **Interfaces** tab.

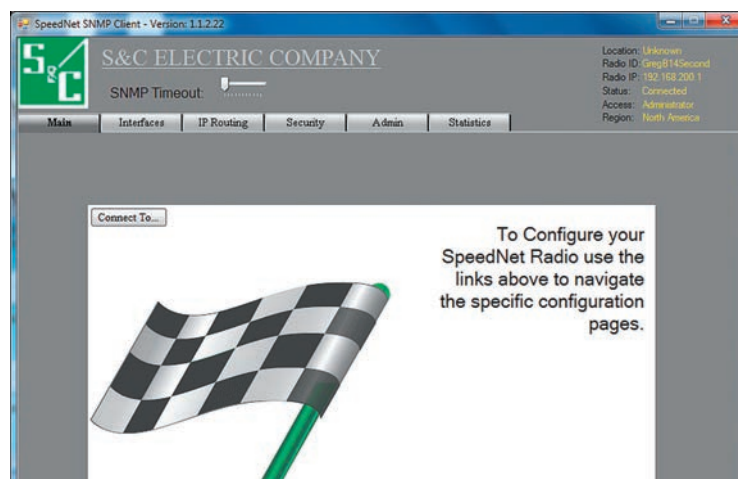

Figure 4. Main screen for SpeedNet configuration.

STEP 14. The *Interfaces* screen will open. Click on the **Wireless** tab. See Figure 5.

STEP 15. Change the IP Address to: **192.168.202.10**, and click on the **Apply** button..

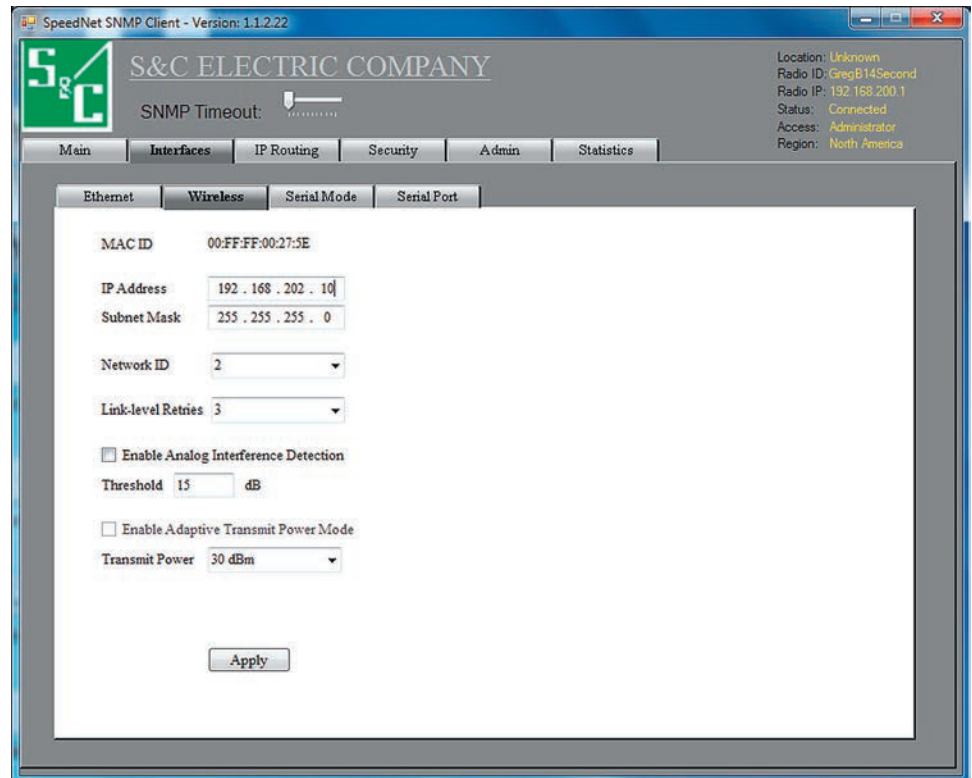

Figure 5. Wireless configuration dialog box.

STEP 16. Open the Client Tool (see Figure 6 on page 10) and enter:

IP Address: 192.168.200.1

Username: <Default Credentials>

Password: <Default Credentials>

STEP 17. Click on the **Login** button.

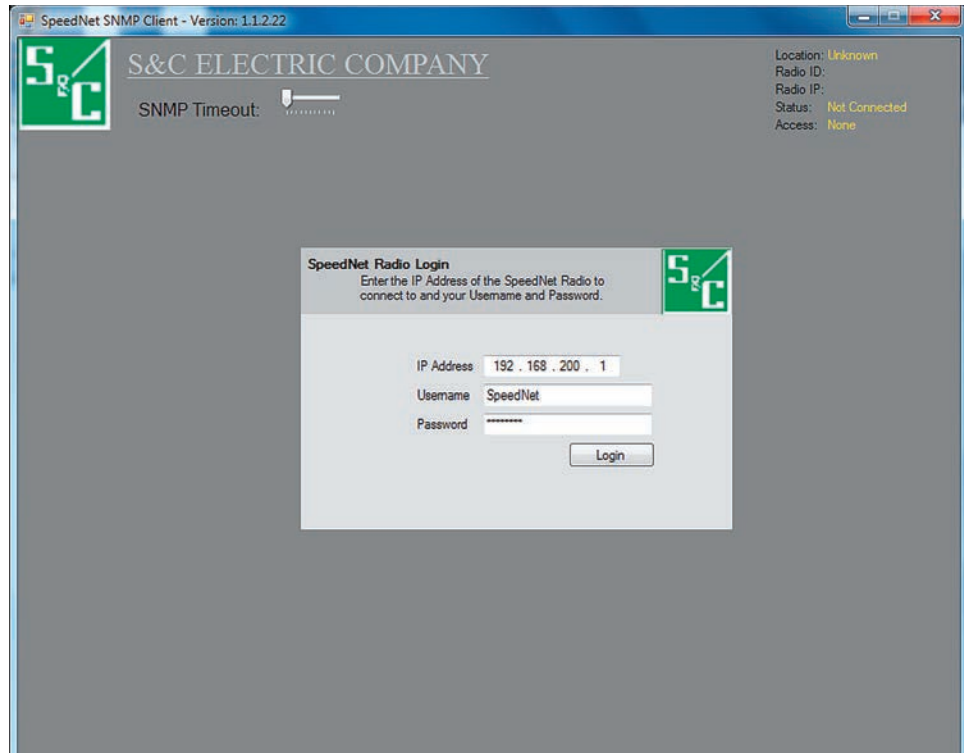

Figure 6. SpeedNet Radio login dialog box.

STEP 18. The *Main* screen will open, as shown in Figure 4 on page 8. Click on the **Interfaces** tab.

STEP 19. The *Interfaces* screen will open. Click on the **Ethernet** tab. See Figure 7.

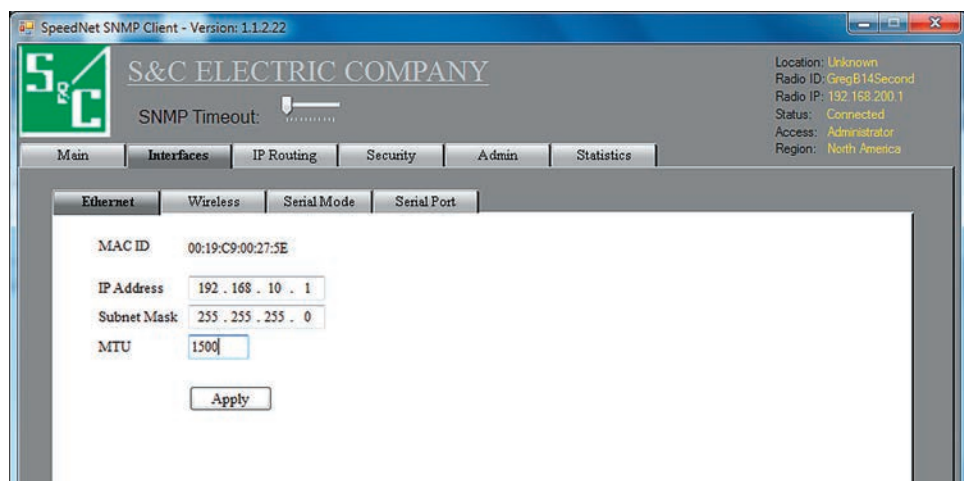

Figure 7. Ethernet configuration dialog box.

Basic Network Configuration

STEP 20. Change the IP Address to: **192.168.10.1**, and click on the **Apply** button.

In Step 20, we changed the Ethernet IP address of Radio #10. Now, in order for the PC to communicate with the radio at the new address, we must change the directly connected PC's Ethernet port IP address to match in the following Steps 21 through 24.

STEP 21. Open the Local Area Connection Properties dialog box on Laptop #1. Scroll and select the **Internet Protocol Version 4 (TCP/IPv4)** option. See Figure 8.

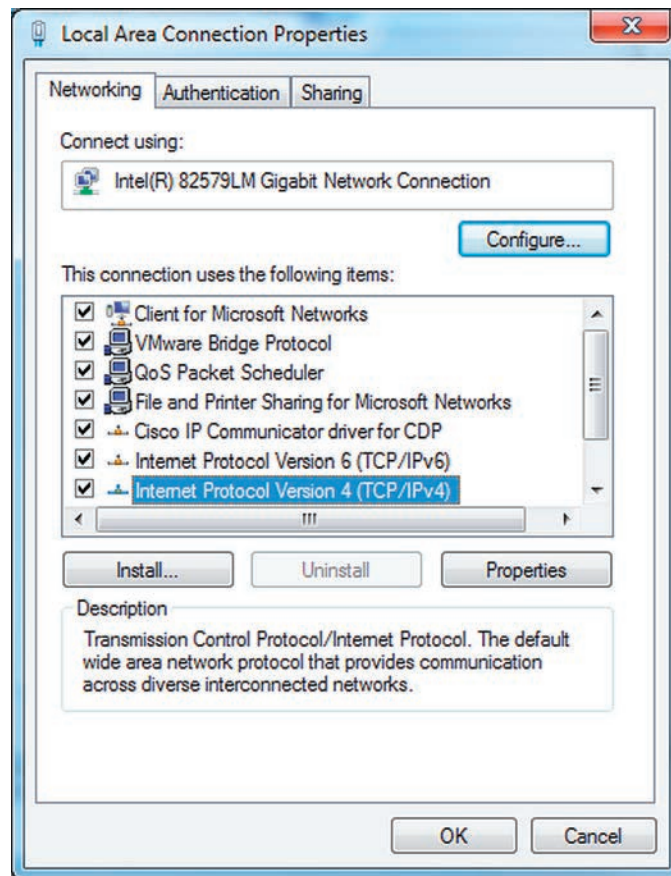

Figure 8. Local Area Connection Properties dialog box.

SpeedNet Configuration

STEP 22. The Internet Protocol Version 4 (TCP/IPv4) Properties dialog box will open. See Figure 9. Left click on the **Use the Following IP address** option.

STEP 23. Enter the following:

IP address: 192.168.10.50

Subnet Mask: 255.255.255.0

Default Gateway: 192.168.10.1

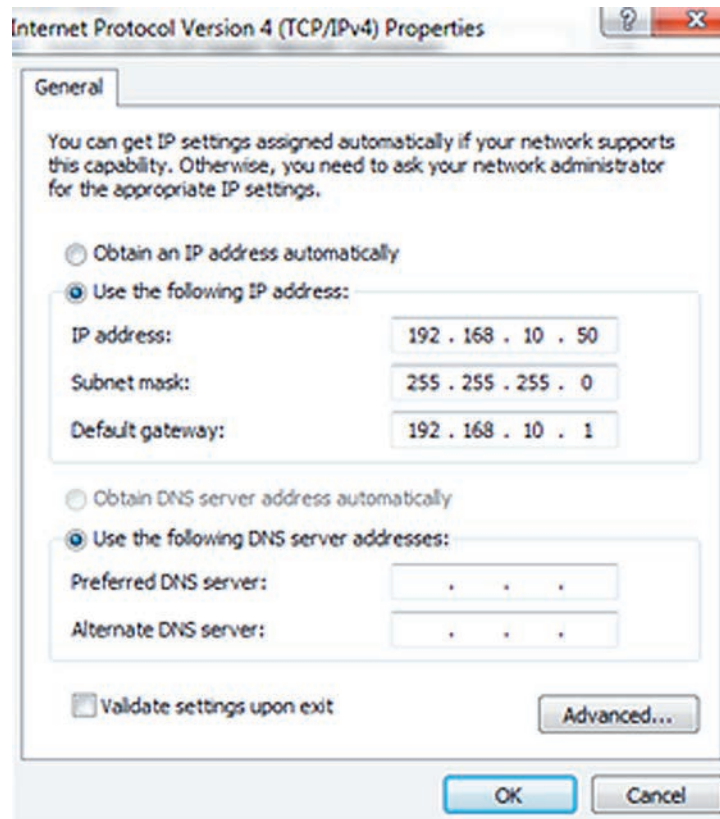

Figure 9. Internet Protocol Version 4 (TCP/IPv4) Properties dialog box.

STEP 24. Click the **OK** button on the Internet Protocol Version 4 (TCP/IPv4) Properties dialog box.

STEP 25. Click the **Close** button on the Local Area Connection Properties dialog box. In steps 26 through 28, we verify connectivity to Radio #10 using first ping and then a client tool login. Using ping and then a client tool login are common steps used to verify connectivity in deployed SpeedNet systems.

STEP 26. Open the Windows Command Prompt and verify connectivity to Radio #10 with this command: **C:\Documents and Settings\>ping 192.168.10.1**

STEP 27. Open the Client Tool (see Figure 10) and enter:

IP Address: 192.168.10.1

Username: <Default Credentials>

Password: <Default Credentials>

STEP 28. Click on the **Login** button.

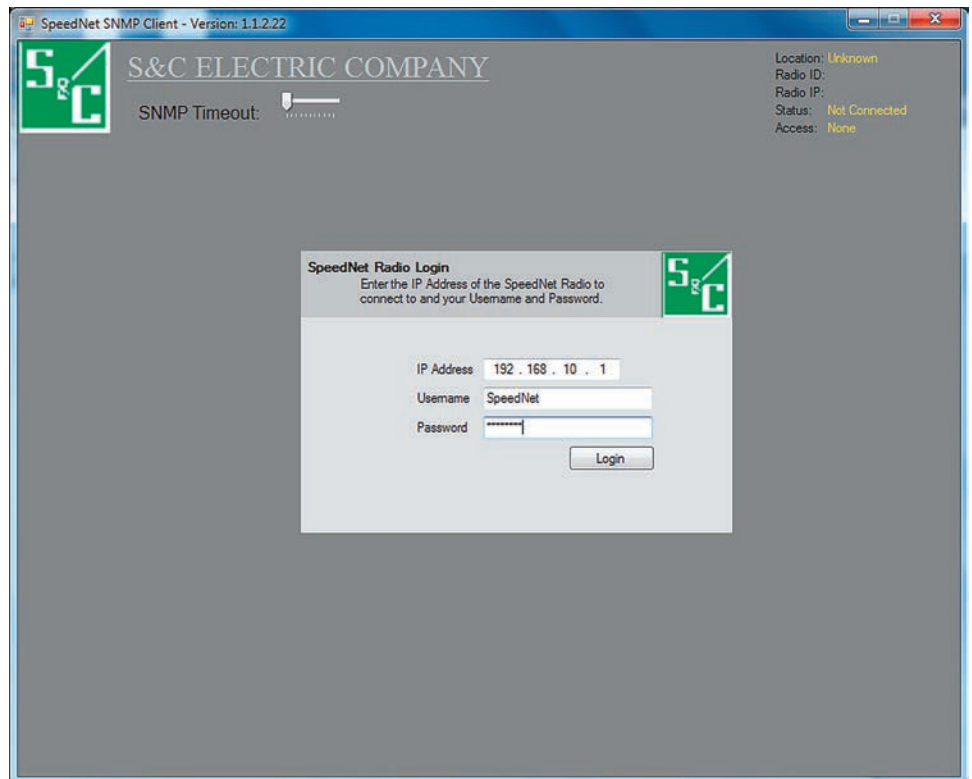

Figure 10. SpeedNet Radio login dialog box.

You have just set up a SpeedNet Radio.

Building a Two-Node Network

Follow these step to build a two-node network:

STEP 1. Power up another demo radio and label it as Radio #20

STEP 2. Connect antenna.

STEP 3. Observe that Radio #20 synchronizes with Radio #10, as indicated by a solid green **Wireless Link LED** on the front panel of both radios.

STEP 4. Via Radio #10, access the *Client Tool>Stats>AODV* screen.

STEP 5. Verify that Radio #20 has “neighbored up,” 192.168.202.1, by observing that the factory default wireless IP address 192.168.202.1 now appears in the Radio 10 AODV Neighbor list.

STEP 6. Access Radio #20 with the Client Tool. See Figure 11. Open the Client Tool and enter:

IP Address: 192.168.200.1

Username: <Default Credentials>

Password: <Default Credentials>

STEP 7. Click on the **Login** button.

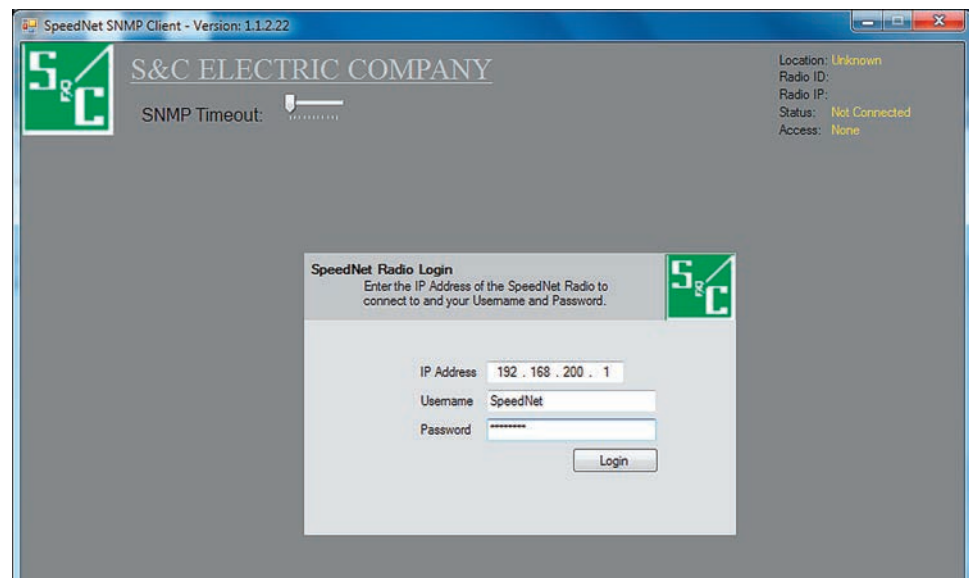

Figure 11. SpeedNet Radio login dialog box.

At this point, you have logged into Radio #20 through Radio #10 using Radio #20's factory-default Ethernet IP address of 192.168.200.1. Radio #10 is functioning as a router to accomplish this. Radio #10 is the PC's default gateway and is routing your client login traffic to/from Radio #20. No change to the PC's settings was required because the radio to which it was directly connected had no configuration changes to its Ethernet port IP settings. It is important to change the PC address, mask, and default gateway when changes are made to the attached radio's Ethernet port IP settings.

STEP 8. The *Main* screen will open, as shown in Figure 12. Click the **Interfaces** tab.

STEP 9. The *Interfaces* screen will open. Click the **Ethernet** tab. See Figure 13.

STEP 10. Change the IP Address to: **192.168.20.1**, and click on the **Apply** button.

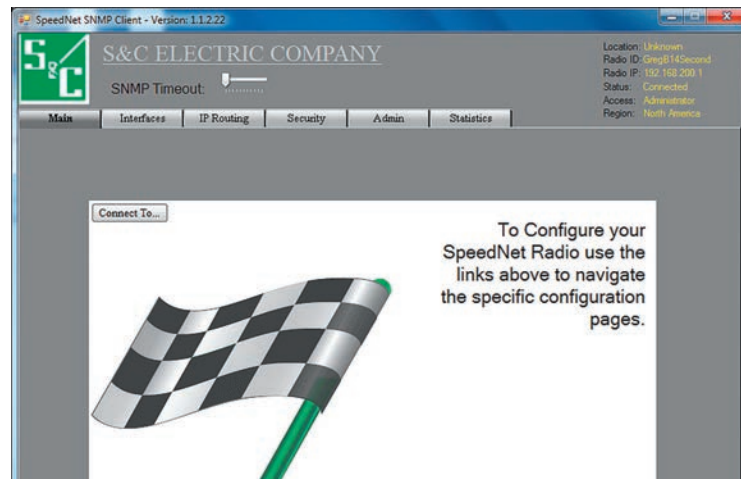

Figure 12. *Main* screen for SpeedNet configuration.



Figure 13. Ethernet configuration dialog box.

Building a Two-Node Network

STEP 11. Open the Client Tool (see Figure 14) and enter:

IP Address: 192.168.20.1

Username: <Default Credentials>

Password: <Default Credentials>

STEP 12. Click on the **Login** button.

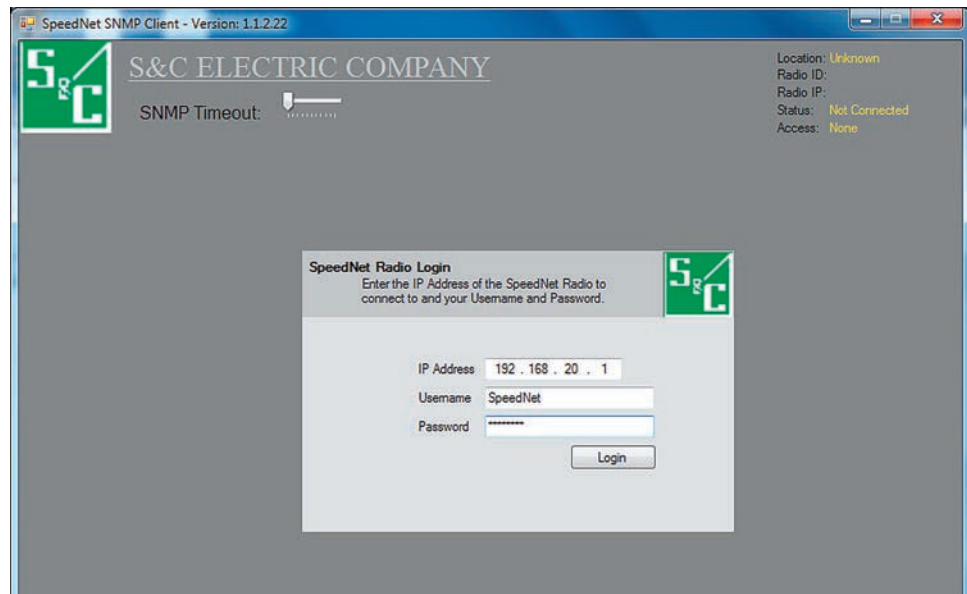

Figure 14. SpeedNet Radio login dialog box.

STEP 13. The *Main* screen will open, as shown in Figure 15. Click the **Interfaces** tab. See Figure 15.

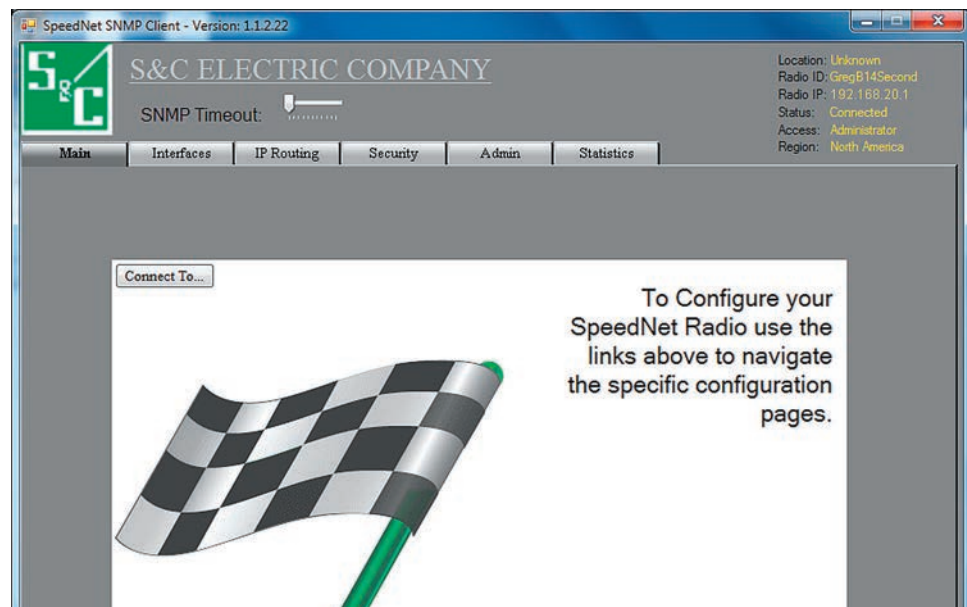

Figure 15. Main screen for SpeedNet configuration.

STEP 14. The *Interfaces* screen will open. Click the **Wireless** tab. See Figure 16.

STEP 15. Change the IP Address to: **192.168.202.20**, and click on the **Apply** button.

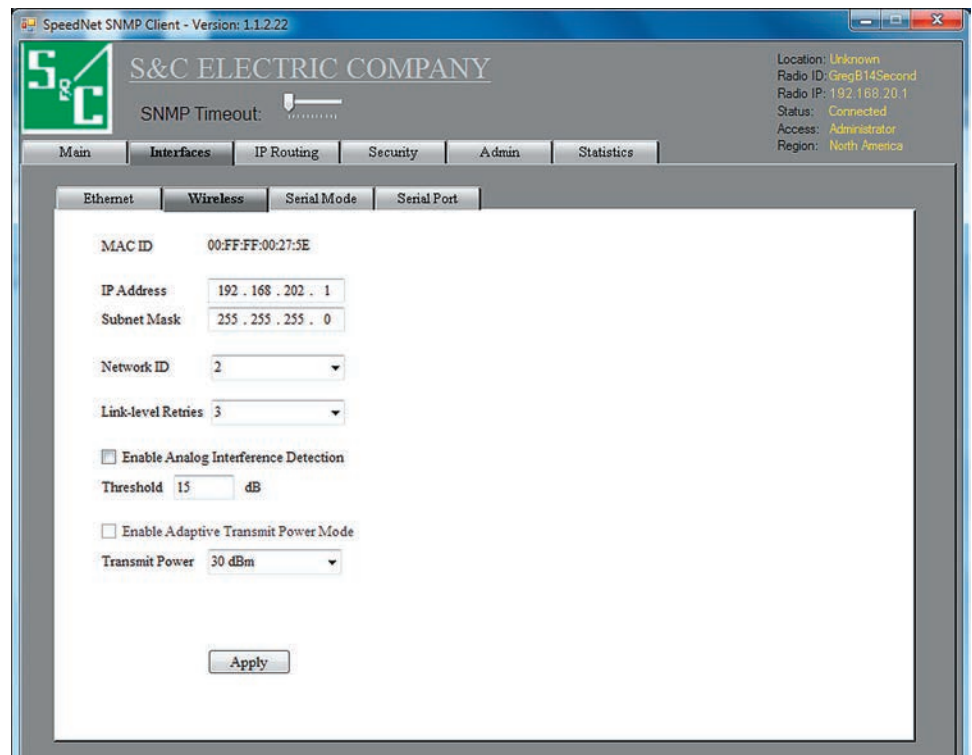

Figure 16. Wireless configuration dialog box.

STEP 16. Access the Client Tool and login to the Radio #10 IP address: 192.168.10.1. (This is the Wireless IP address of the radio attached to your PC. Generally, you can log into a radio using either of its two addresses.)

STEP 17. Go to the *Tab>Stats>AODV* screen, and verify that Radio #20 has “neighbored up,” by checking for the address: 192.168.202.20 in the Statistics/AODV neighbor table of Radio #10.

You have just set up a two-node network.

Single Link Testing

Testing with a 32-Byte Payload

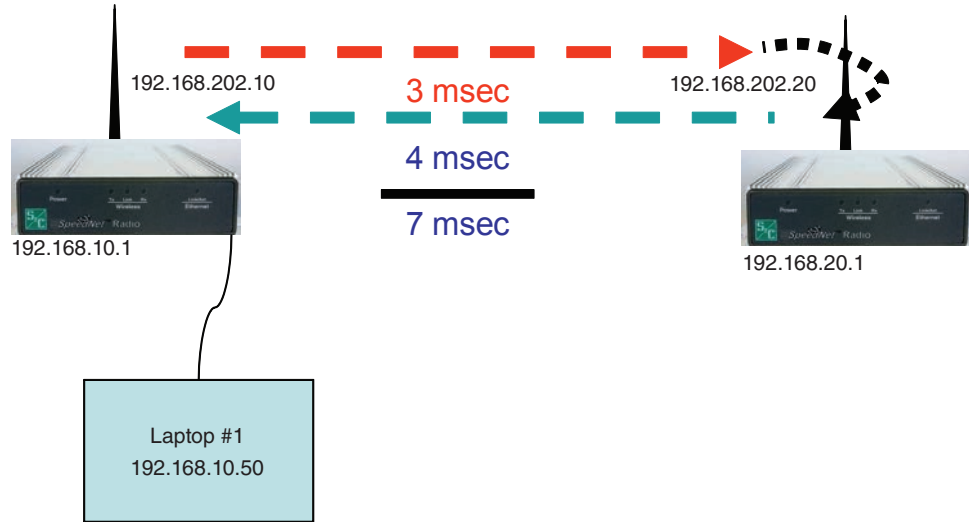

Figure 17. Single link latency test with 32 byte payload.

Follow these step to test with a 32-byte payload:

Step 1. See Figure 17. Open the Windows Command Prompt and verify connectivity to Radio #10 with this command: `C:\Documents and Settings>ping 192.168.20.1 -n 300`.

Step 2. After the initial ping establishes the route, roundtrip latency should be around 6 to 8 msec with no packet loss.

Testing with a 300-Byte Payload

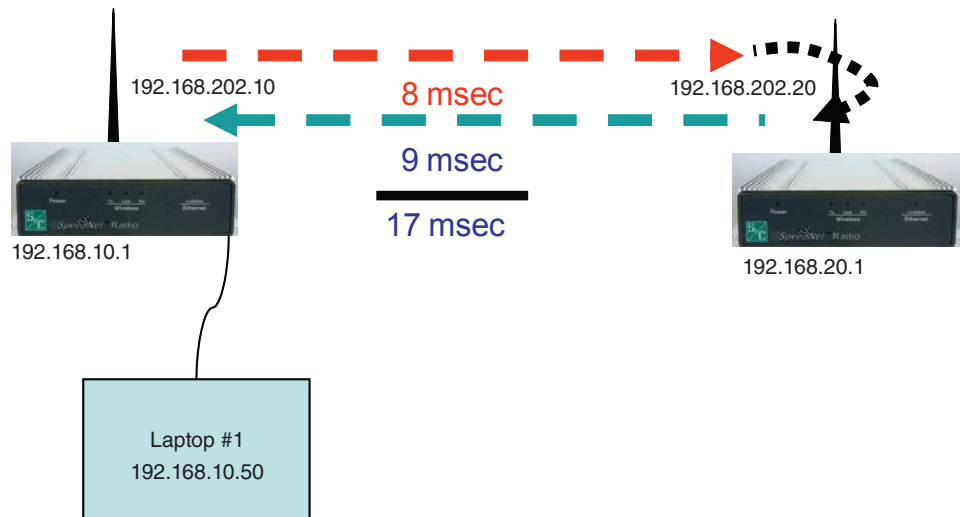

Figure 18. Single link latency test with 300 byte payload.

Follow these steps to test with a 300-byte payload:

Step 1. See Figure 18. Open the Windows Command Prompt and verify connectivity to Radio #10 with this command: `C:\Documents and Settings>ping 192.168.20.1 -n 300 -l 300`.

Step 2. Roundtrip latency is 16 to 18 msec with no packet loss.

Testing Bandwidth with Iperf

Iperf is a shareware tool developed to assess the performance of a network link. It can measure the bandwidth, packet loss latency, and jitter of a link. S&C recommends using Iperf for SpeedNet demonstrations and lab evaluations.

NOTICE

For Windows Vista and higher, Iperf must run in **Administrative Privilege** mode. To run in **Administrative Privilege** mode: go to the *Start>All Programs>Accessories* screen. Then, navigate to Command Prompt and right click to select the **Run as Administrator** option.



Figure 19. Testing single-link bandwidth.

Follow these steps to test bandwidth with Iperf:

- STEP 1.** Configure your single-link network with the IP addresses shown in Figure 19.
- STEP 2.** Install Iperf in both laptop computers. Use DOS prompt to go to the Iperf directory on both computers.
- STEP 3.** Set up Iperf Server on Laptop #1 listening on UDP port 5001, UDP window size: 8.00 KByte (default).
Run `iperf -s -u -l 565 -t 30 -i 10` as shown in Figure 20.

```

C:\Temp\Iperf>iperf -s -u -l 565 -t 30 -i 10
Server listening on UDP port 5001
Receiving 565 byte datagrams
UDP buffer size: 8.00 KByte (default)
-----
[1928] local 192.168.220.50 port 5001 connected with 192.168.214.7 port 2849
[ ID] Interval      Transfer      Bandwidth      Jitter    Lost/Total Datagrams
[1928] 0.0-10.0 sec   335 KBytes    275 Kbits/sec  1.967 ms  1162690894/ 608 (1.9e+008%)
[1928] 10.0-20.0 sec 336 KBytes    275 Kbits/sec  3.993 ms   0/ 609 (0%)
[1928] 20.0-30.0 sec 335 KBytes    275 Kbits/sec  2.333 ms   0/ 608 (0%)
[1928] 0.0-30.0 sec 1008 KBytes    275 Kbits/sec  2.051 ms   0/ 1827 (0%)
[1928] local 192.168.220.50 port 5001 connected with 192.168.214.7 port 2850
[ ID] Interval      Transfer      Bandwidth      Jitter    Lost/Total Datagrams
[1928] 0.0-10.0 sec   336 KBytes    275 Kbits/sec  1.841 ms   0/ 609 (0%)
[1928] 10.0-20.0 sec 335 KBytes    275 Kbits/sec  3.653 ms   0/ 608 (0%)
[1928] 20.0-30.0 sec 336 KBytes    275 Kbits/sec  2.513 ms   0/ 609 (0%)
[1928] 0.0-30.0 sec 1008 KBytes    275 Kbits/sec  2.356 ms   0/ 1827 (0%)

```

Figure 20. Iperf screen shown at the server side.

STEP 4. Set up Iperf Client on Laptop #2. Run `iperf -c 192.168.10.50 -u -l 565 -t 30 -b 275k -i 10` as shown in Figure 21.

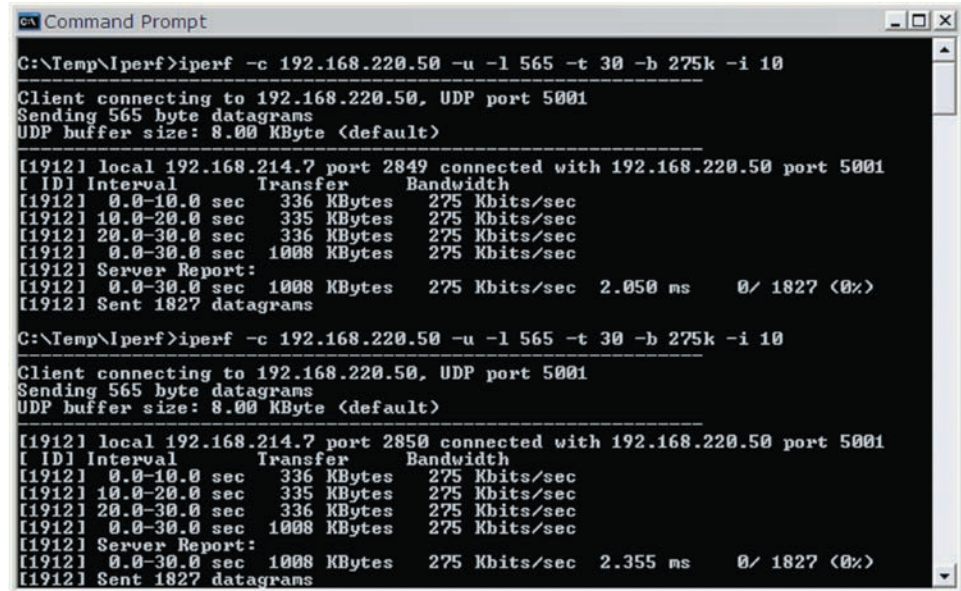

```
GA Command Prompt
C:\Temp\Iperf>iperf -c 192.168.220.50 -u -l 565 -t 30 -b 275k -i 10
-----
Client connecting to 192.168.220.50, UDP port 5001
Sending 565 byte datagrams
UDP buffer size: 8.00 KByte (default)
-----
[1912] local 192.168.214.7 port 2849 connected with 192.168.220.50 port 5001
[ ID] Interval      Transfer      Bandwidth
[1912]  0.0-10.0 sec   336 KBytes    275 Kbits/sec
[1912] 10.0-20.0 sec   335 KBytes    275 Kbits/sec
[1912] 20.0-30.0 sec   336 KBytes    275 Kbits/sec
[1912]  0.0-30.0 sec  1008 KBytes    275 Kbits/sec
[1912] Server Report:
[1912]  0.0-30.0 sec  1008 KBytes    275 Kbits/sec    2.050 ms    0/ 1827 (0%)
[1912] Sent 1827 datagrams

C:\Temp\Iperf>iperf -c 192.168.220.50 -u -l 565 -t 30 -b 275k -i 10
-----
Client connecting to 192.168.220.50, UDP port 5001
Sending 565 byte datagrams
UDP buffer size: 8.00 KByte (default)
-----
[1912] local 192.168.214.7 port 2850 connected with 192.168.220.50 port 5001
[ ID] Interval      Transfer      Bandwidth
[1912]  0.0-10.0 sec   336 KBytes    275 Kbits/sec
[1912] 10.0-20.0 sec   335 KBytes    275 Kbits/sec
[1912] 20.0-30.0 sec   336 KBytes    275 Kbits/sec
[1912]  0.0-30.0 sec  1008 KBytes    275 Kbits/sec
[1912] Server Report:
[1912]  0.0-30.0 sec  1008 KBytes    275 Kbits/sec    2.355 ms    0/ 1827 (0%)
[1912] Sent 1827 datagrams
```

Figure 21. *Iperf* screen shown at the client side.

Follow these steps to build a three-node network:

STEP 1. Power up a third radio and label it Radio #30.

STEP 2. Connect the Rubber Duck antenna.

STEP 3. Open the Client Tool and tab to the *Stats>AODV* screen, and verify that Radio #30 has “neighbored up” by observing that the factory default wireless IP address 192.168.202.1 now appears in the AODV neighbor list.

STEP 4. Open the Client Tool (see Figure 22) and enter:

IP Address: 192.168.202.1

Username: <Default Credentials>

Password: <Default Credentials>

STEP 5. Click on the **Login** button.

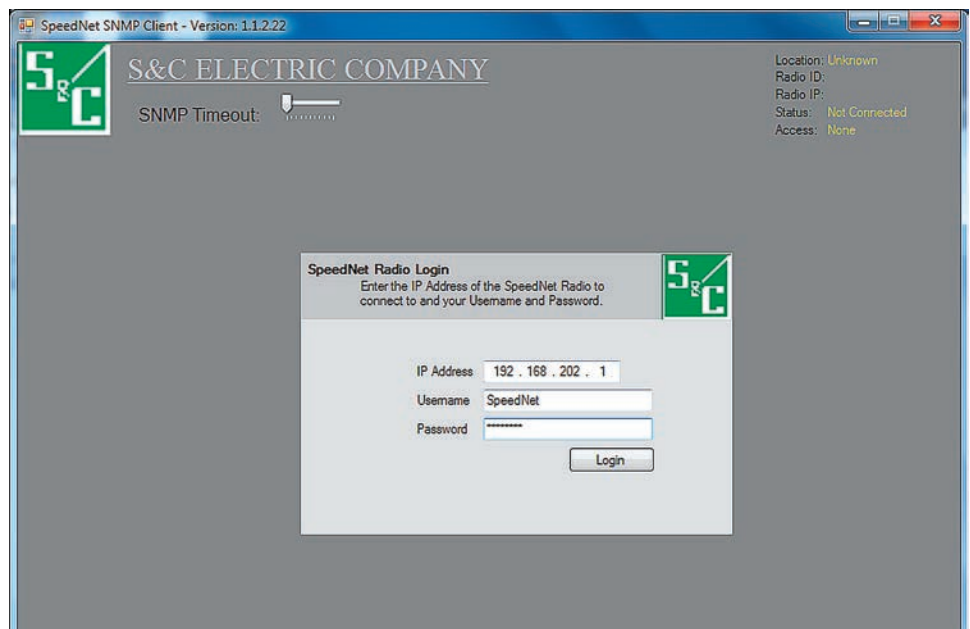

Figure 22. SpeedNet Radio login dialog box.

Building a Three-Node Network

STEP 6. The *Main* screen will open, as shown in figure 23. Click on the **Interfaces** tab.

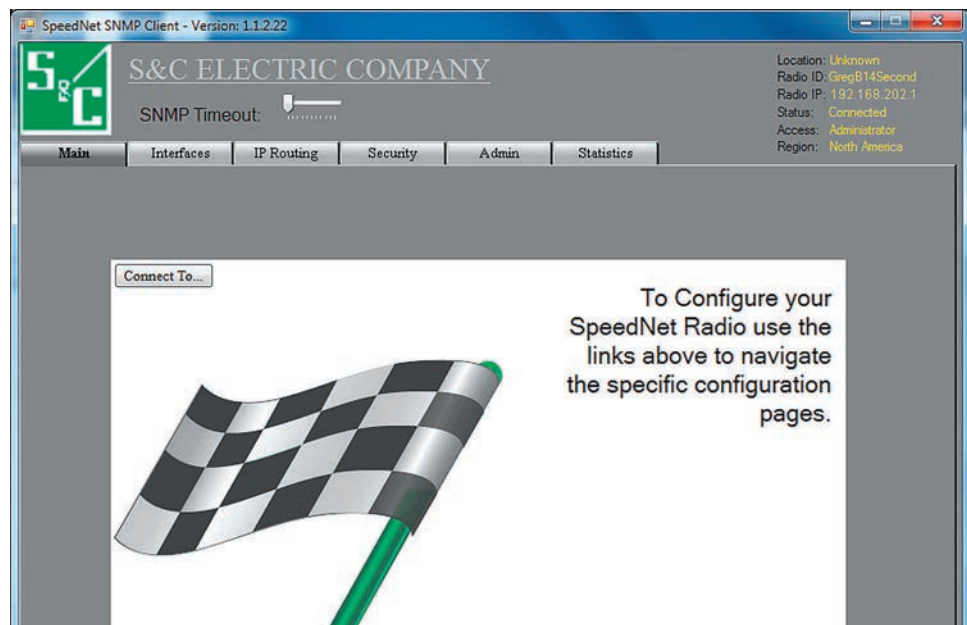

Figure 23. *Main* screen for SpeedNet configuration.

STEP 7. The *Interfaces* screen will open. Click on the **Ethernet** tab. See Figure 24.

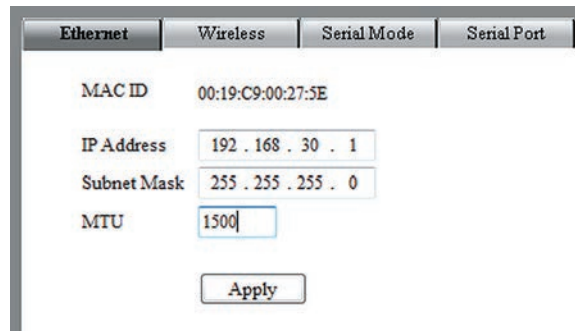

Figure 24. Wireless configuration dialog box.

STEP 8. Change the IP Address to: **192.168.30.1**, and click on the **Apply** button.

STEP 9. Open the Client Tool (see Figure 25) and enter:

IP Address: 192.168.30.1

Username: <Default Credentials>

Password: <Default Credentials>

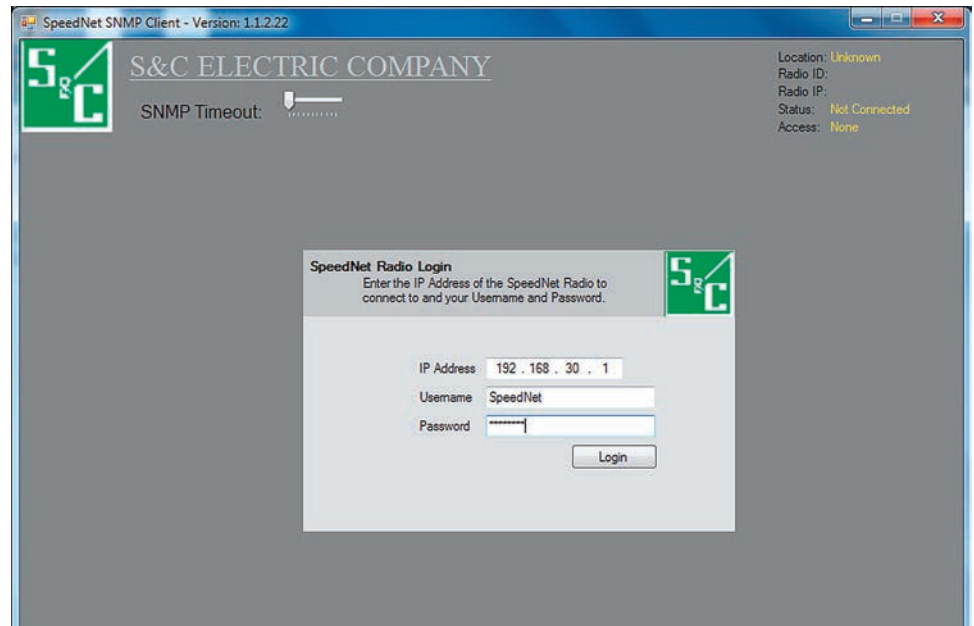

Figure 25. SpeedNet Radio login dialog box.

STEP 10. Click on the **Login** button.

STEP 11. The *Main* screen will open, as shown in Figure 26. Click on the **Interfaces** tab.

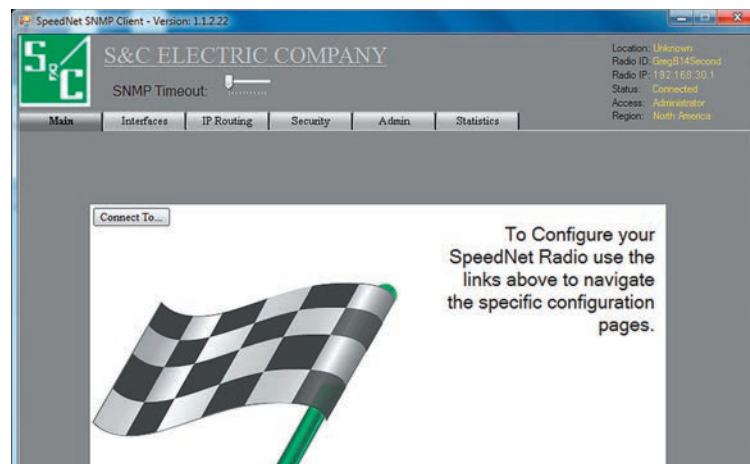

Figure 26. Main screen for SpeedNet Radio configuration.

Building a Three-Node Network

STEP 12. The *Interfaces* screen will open. Click on the **Wireless** tab. See Figure 27.

STEP 13. Change the IP Address to: **192.168.202.30**, and click on the **Apply** button.



The image shows a software interface for configuring wireless settings. At the top, there are four tabs: "Ethernet", "Wireless", "Serial Mode", and "Serial Port". The "Wireless" tab is selected. Below the tabs, the following settings are visible:

- MAC ID: 00:FF:FF:00:27:5E
- IP Address: 192 . 168 . 202 . 30
- Subnet Mask: 255 . 255 . 255 . 0
- Network ID: 2 (dropdown menu)
- Link-level Retries: 3 (dropdown menu)
- Enable Analog Interference Detection
- Threshold: 15 dB
- Enable Adaptive Transmit Power Mode
- Transmit Power: 30 dBm (dropdown menu)

At the bottom center of the dialog box is an "Apply" button.

Figure 27. Wireless configuration dialog box.

At this point, you have constructed a three-node SpeedNet network where all three radios can communicate directly with one another.

In the next five steps, you will use attenuators to force a change in routing and observe the establishment of a new route. The attenuation installed on Radio #10 and Radio #30 will prevent them from directly “seeing” one another due to an overall additional attenuation of 180 dB between them. However, because Radio #20 has no additional attenuation, it should still “see” both Radio #10 and Radio #30 through their 90 dB each of attenuation, enabling it to route traffic between them.

STEP 1. At Radio #10, install three 30-dB attenuators between the antenna and the antenna connector.

STEP 2. At Radio #30, install three 30-dB attenuators between the antenna and the antenna connector. See Figure 28.

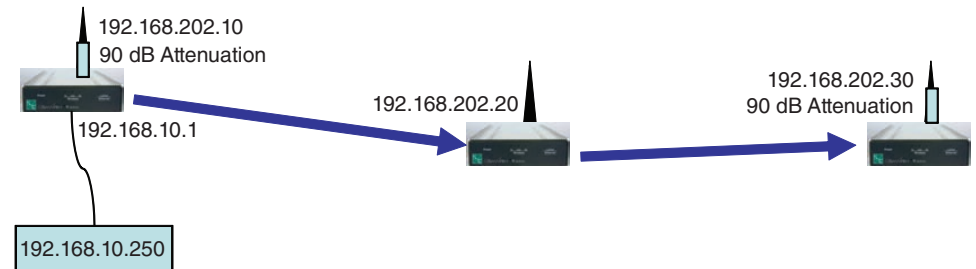

Figure 28. Testing for route discovery.

STEP 3. Open the Windows Command Prompt and run the command `C:\ping 192.168.202.30 -t`.

STEP 4. In this order, access Node 30 and reboot, access Node 20 and reboot, and access Node 10 and reboot. A route is established between Node 10 and Node 30 >10 seconds.

Building a Four-Node Network

Follow these steps to build a four-node network:

STEP 1. Power up a fourth radio and label it Radio #40.

STEP 2. Connect the Rubber Duck antenna.

STEP 3. Via Radio #10 access the Client Tool and tab to the *Stats>AODV* screen, and verify that Radio #40 has “neighbored up” by observing that the factory-default wireless IP address 192.168.202.1 now appears in Radio #10’s AODV neighbor table.

STEP 4. Open the Client Tool (see Figure 29) and enter:

IP Address: 192.168.202.1

Username: <Default Credentials>

Password: <Default Credentials>

STEP 5. Click on the **Login** button.

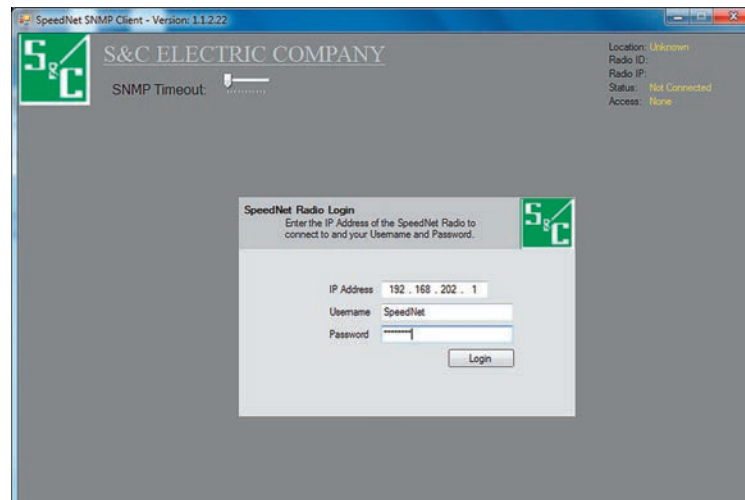

Figure 29. SpeedNet Radio login dialog box.

STEP 6. The *Main* screen will open, as shown in Figure 30. Click on the **Interfaces** tab.

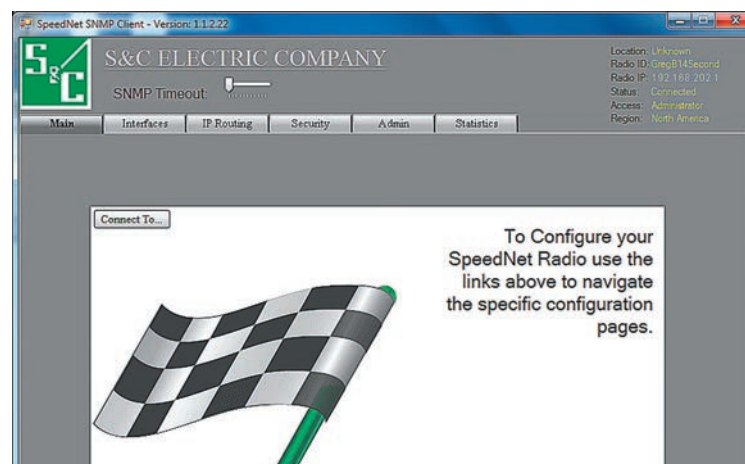
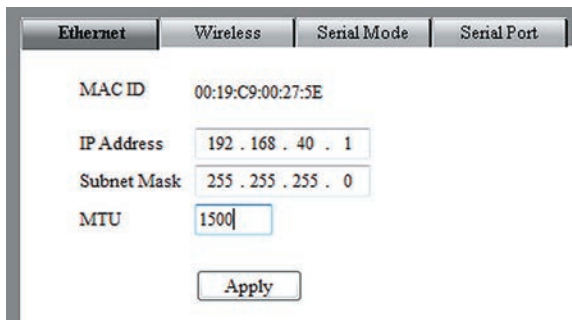

Figure 30. Main screen for SpeedNet configuration.

STEP 7. The *Interfaces* screen will open. Click on the **Ethernet** tab. See Figure 31.

STEP 8. Change the IP Address to: **192.168.40.1**, and click on the **Apply** button.



The screenshot shows a configuration window with four tabs: Ethernet, Wireless, Serial Mode, and Serial Port. The Ethernet tab is selected. The configuration fields are as follows:

MAC ID	00:19:C9:00:27:5E
IP Address	192 . 168 . 40 . 1
Subnet Mask	255 . 255 . 255 . 0
MTU	1500

At the bottom of the dialog is an **Apply** button.

Figure 31. Wireless configuration dialog box.

STEP 9. Open the Client Tool (see Figure 32) and enter:

IP Address: 192.168.40.1

Username: <Default Credentials>

Password: <Default Credentials>

STEP 10. Click on the **Login** button.

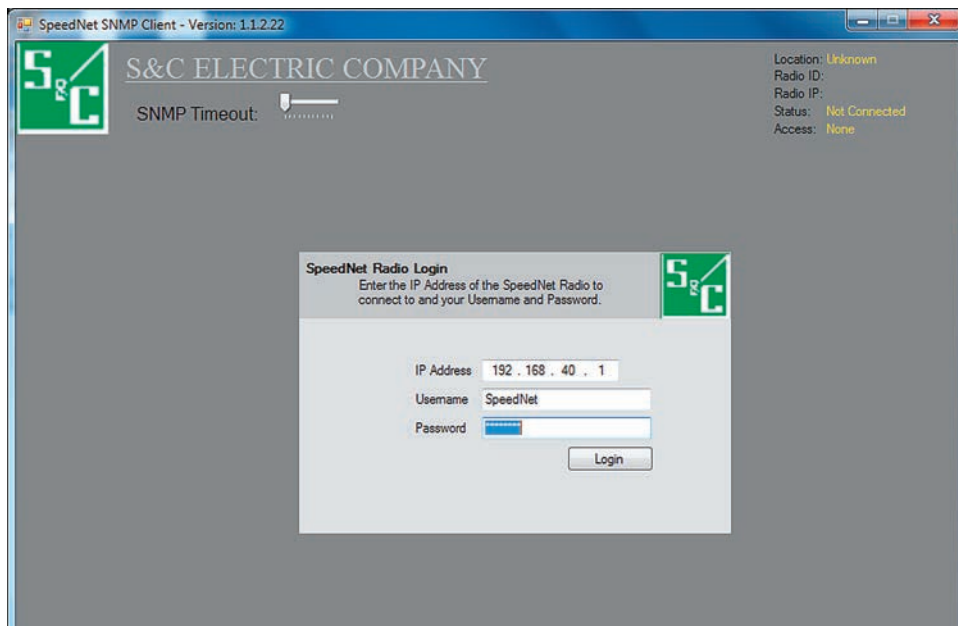

The screenshot shows the SpeedNet SNMP Client application window. The title bar reads "SpeedNet SNMP Client - Version: 1.1.2.22". The main window has a header with the S&C logo and "S&C ELECTRIC COMPANY". Below the header is an "SNMP Timeout" slider. In the top right corner, there is a status area with the following information:

- Location: Unknown
- Radio ID:
- Radio IP:
- Status: Not Connected
- Access: None

In the center of the window is a "SpeedNet Radio Login" dialog box. It contains the following fields:

- IP Address: 192 . 168 . 40 . 1
- Username: SpeedNet
- Password: [masked]

A **Login** button is located at the bottom right of the dialog box.

Figure 32. SpeedNet Radio login dialog box.

STEP 11. The *Main* screen will open, as shown in Figure 33. Click on the the **Interfaces** tab.

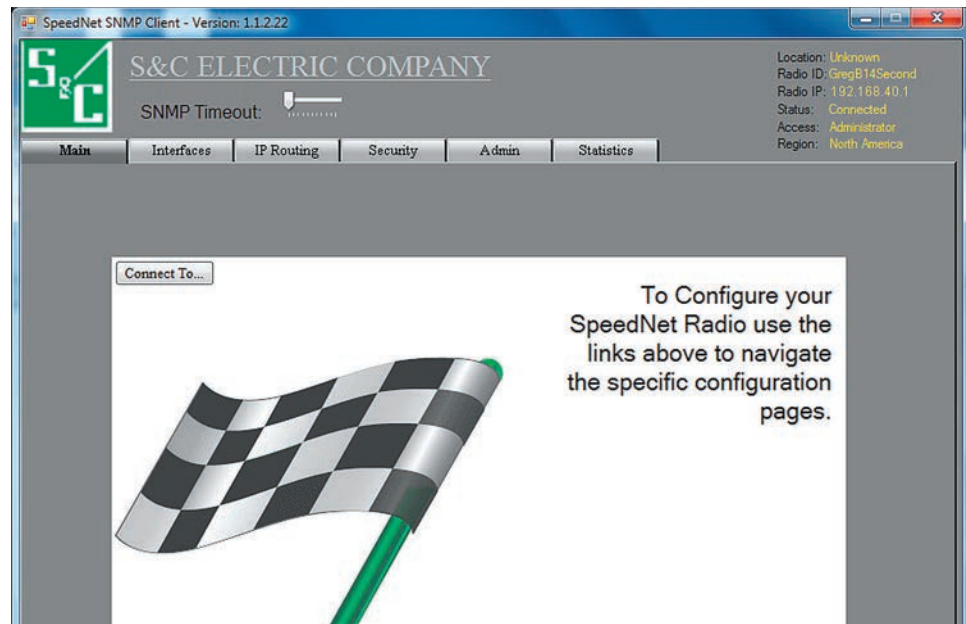

Figure 33. Main screen for SpeedNet configuration.

STEP 12. The *Interfaces* screen will open. Click on the **Wireless** tab. See Figure 34.

STEP 13. Change the *IP Address* to: **192.168.202.40**, and click on the **Apply** button.

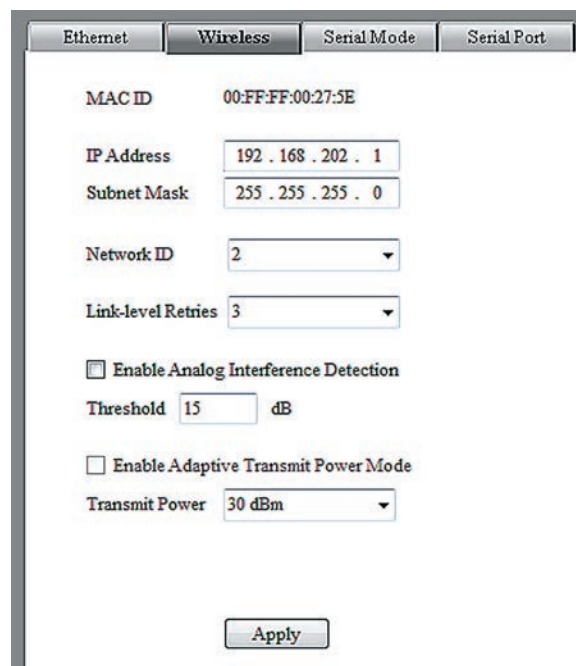

Figure 34. Wireless configuration dialog box.

Follow these steps to test alternate routing:

STEP 1. Install one 30dB attenuator between the antenna and the antenna connector of Radio 20. See Figure 35 for the network diagram.

STEP 2. Ping Radio #30.

STEP 3. Tracert to Radio #30.

STEP 4. Observe the route from Radio #10 to Radio #30 is through Radio #40. See Figure 35. C:\>ping 192.168.202.30 -t. C:\>tracert 192.168.202.30.

Trace the route to 192.168.202.30 over a maximum of 30 hops.

```

1  *      *      *      Request timed out
2. 11 ms  18 ms  18 ms  192.168.202.40
3. 24 ms  24 ms  29 ms  192.168.202.30
    
```

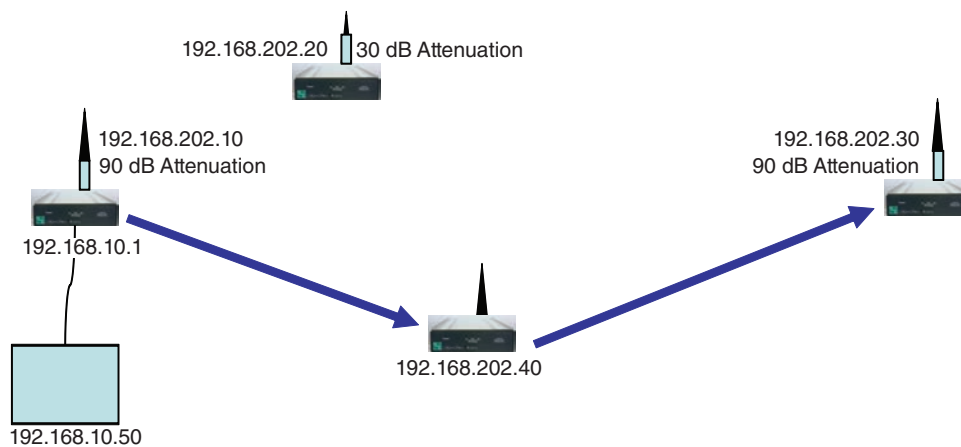

Figure 35. Testing for alternate routing.

STEP 5. Unplug radio power to Radio #40.

Testing Alternate Routing

STEP 6. Observe the pings as the network finds a route through Radio #20. See Figure 36. C:\ping 192.168.202.30 -t. C:\>tracert 192.168.202.30.

Trace the route to 192.168.202.30 over a maximum of 30 hops.

```
1 * * * Request timed out
2. 11 ms 18 ms 18 ms 192.168.202.20
3. 24 ms 24 ms 29 ms 192.168.202.30
```

Route established between Node 10 and Node 20 > 15 seconds.

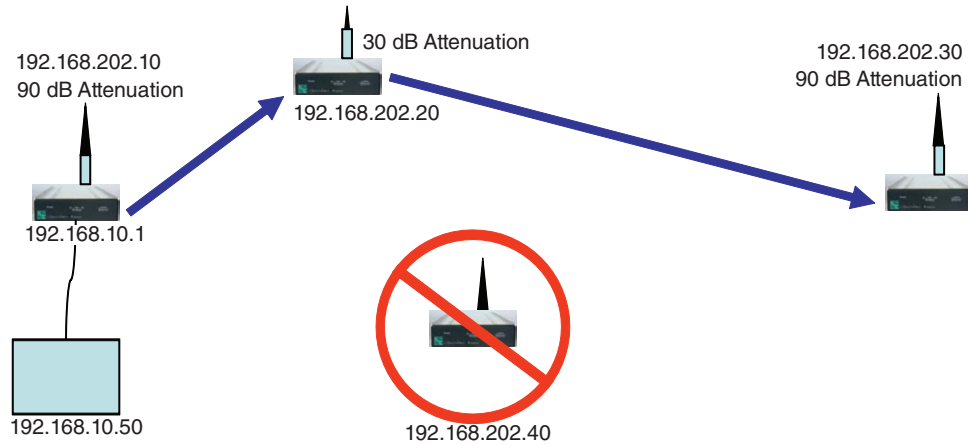

Figure 36. Testing for alternate routing, Node 40 not available.

STEP 7. Re-power Radio #40 and observe the tracert and pings as the node reroutes to optimum performance. See Figure 37. C:\ping 192.168.202.30 -t. C:\>tracert 192.168.202.30.

Trace the route to 192.168.202.30 over a maximum of 30 hops.

```
1 * * * Request timed out
2. 11 ms 18 ms 18 ms 192.168.202.40
3. 24 ms 24 ms 29 ms 192.168.202.30
```

Route established between Node 10 and Node 40 > 15 seconds.

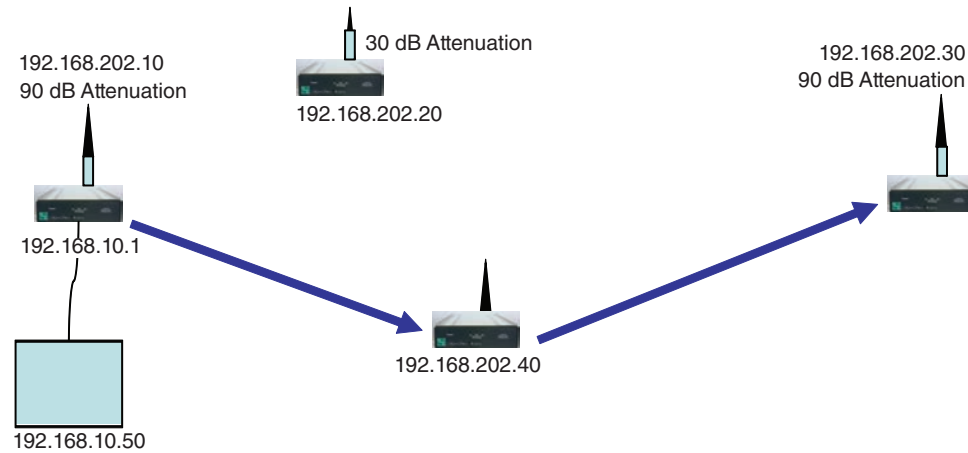

Figure 37. Testing for alternate routing, Node 40 restored.

Follow these steps to build a five-node network:

STEP 1. Power up the fifth radio and label it Radio #50.

STEP 2. Connect the Rubber Duck antenna.

STEP 3. Via Radio #10 access the Client Tool and tab to the *Stats>AODV* screen, and verify that Radio #50 has “neighbored up” by observing that the factory-default wireless IP Address 192.168.200.1 initially used by Radio #50 now appears in Radio#10’s AODV neighbor table.

STEP 4. Open the Client Tool (see Figure 38) and enter:

IP Address: 192.168.200.1

Username: <Default Credentials>

Password: <Default Credentials>

STEP 5. Click on the **Login** button.

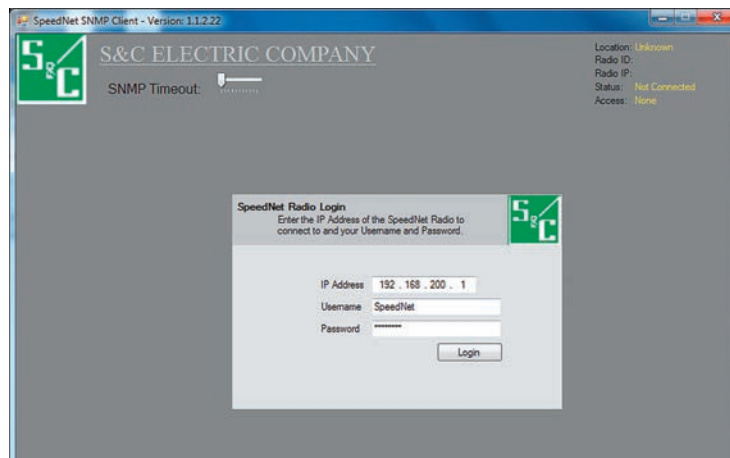

Figure 38. SpeedNet Radio login dialog box.

STEP 6. The *Main* screen will open, as shown in Figure 39. Click on the **Interfaces** tab.

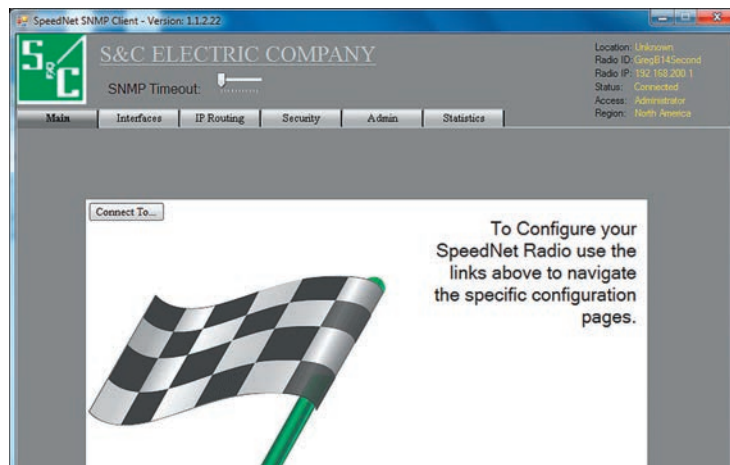
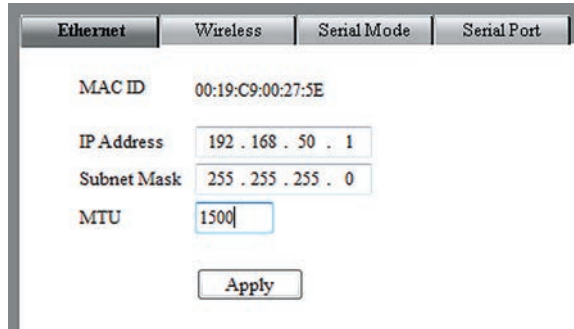

Figure 39. Main screen for SpeedNet configuration.

Building a Five-Node Network

STEP 7. The *Interfaces* screen will open. Click on the **Ethernet** tab. See Figure 40.

STEP 8. Change the IP Address to: **192.168.50.1**, and click on the **Apply** button.



The image shows a configuration dialog box with four tabs: Ethernet, Wireless, Serial Mode, and Serial Port. The Ethernet tab is selected. The configuration fields are as follows:

MAC ID	00:19:C9:00:27:5E
IP Address	192 . 168 . 50 . 1
Subnet Mask	255 . 255 . 255 . 0
MTU	1500

At the bottom of the dialog is an **Apply** button.

Figure 40. Wireless configuration dialog box.

STEP 9. Open the Client Tool (see Figure 41) and enter:

IP Address: 192.168.50.1

Username: <Default Credentials>

Password: <Default Credentials>

STEP 10. Click on the **Login** button.

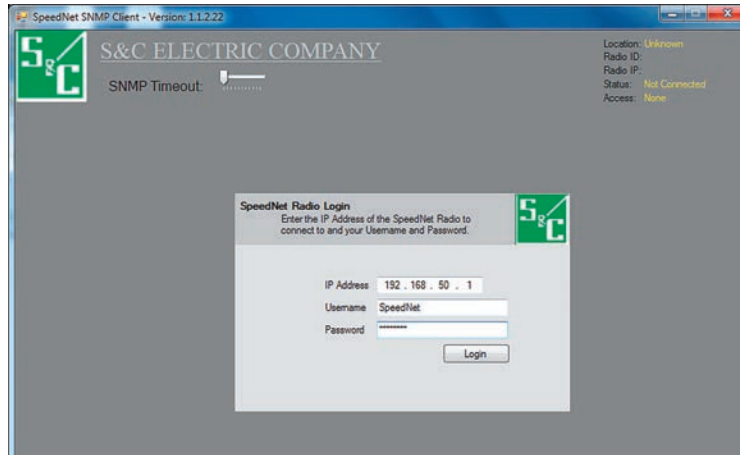

The image shows the SpeedNet SNMP Client - Version: 1.1.2.22 window. The S&C Electric Company logo is in the top left. The main area contains a "SpeedNet Radio Login" dialog box with the following fields:

IP Address	192 . 168 . 50 . 1
Username	SpeedNet
Password	*****

A **Login** button is at the bottom of the dialog box. In the top right corner of the main window, the status is displayed as: Location: Unknown, Radio ID: , Radio IP: , Status: Not Connected, Access: None.

Figure 41. SpeedNet Radio login dialog box.

STEP 11. The *Main* screen will open, as shown in Figure 42. Click on the **Interfaces** tab.

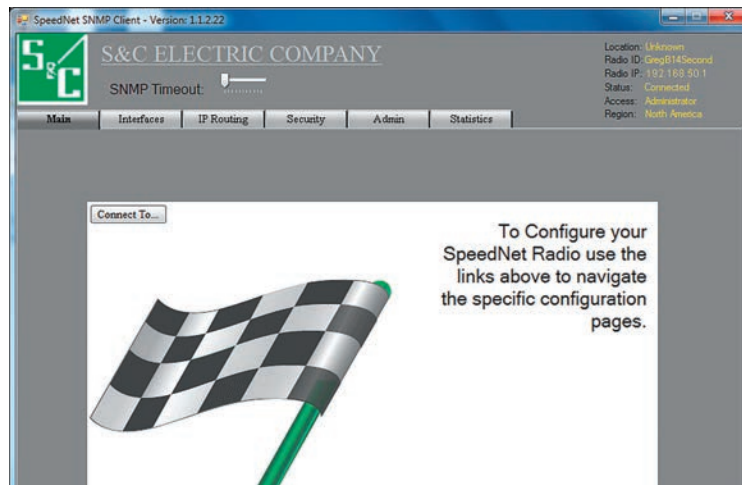

Figure 42. *Main* screen for SpeedNet configuration.

STEP 12. The *Interfaces* screen will open. Click on the **Wireless** tab. See Figure 43.

STEP 13. Change the IP Address to: **192.168.202.50**, and click on the **Apply** button.

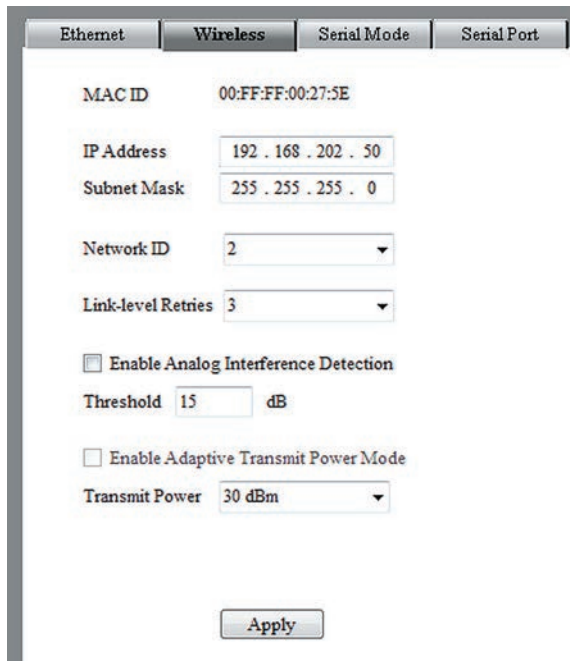

Figure 43. Wireless configuration dialog box.

Point-to-Multipoint Network

Follow these steps to create a point-to-multipoint network:

STEP 1. Configure the radio network as shown in Figure 44.

STEP 2. Observe the results from running the following commands: C:\>ping 192.168.202.30 -t and C:\>tracert 192.168.202.30.

Trace the route to 192.168.202.30 over a maximum of 30 hops.

```
1 * * * Request timed out
2. 11 ms 18 ms 18 ms 102.168.202.50
3. 11 ms 18 ms 18 ms 102.168.202.30
```

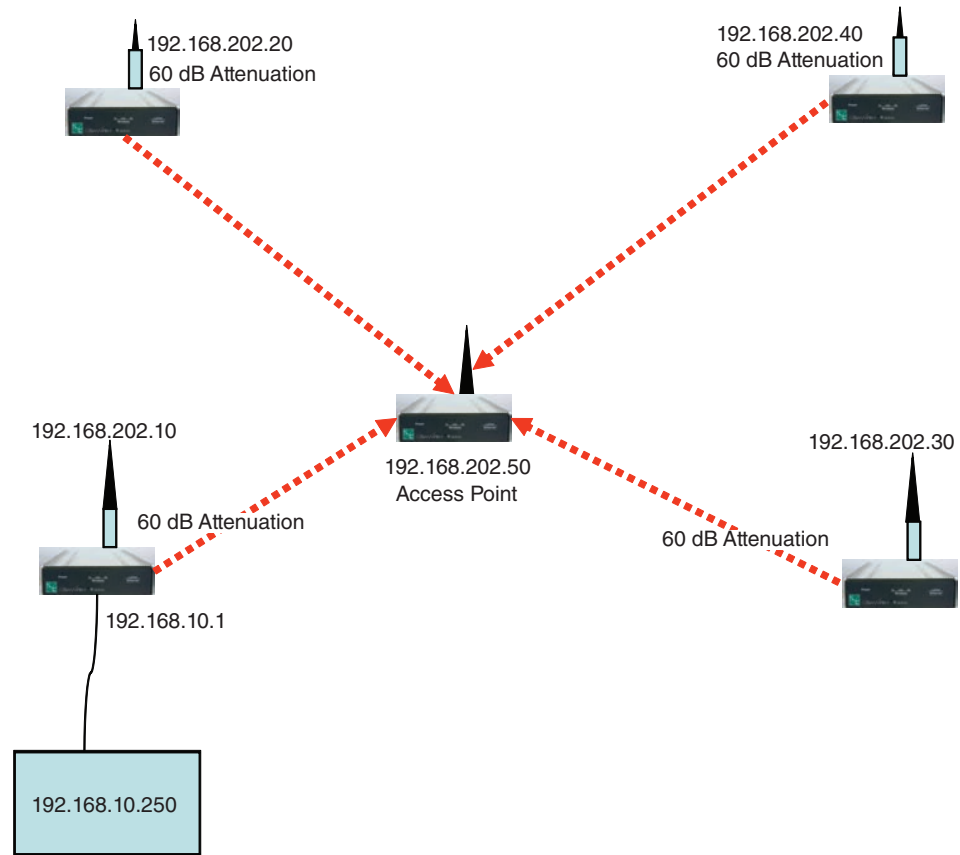

Figure 44. Point-to-multipoint network.

STEP 3. See Figure 45. Remove power from the access point (Radio #50).

STEP 4. Observe the results from running the following commands: C:\ping 192.168.202.30 -t and C:\>tracert 192.168.202.30.

Trace the route to 192.168.202.30 over a maximum of 30 hops.

- ```
1 * * * Request timed out
2. 11 ms 18 ms 18 ms 102.168.202.30
```

Route established between Node 10 and Node 30 > 15 seconds.

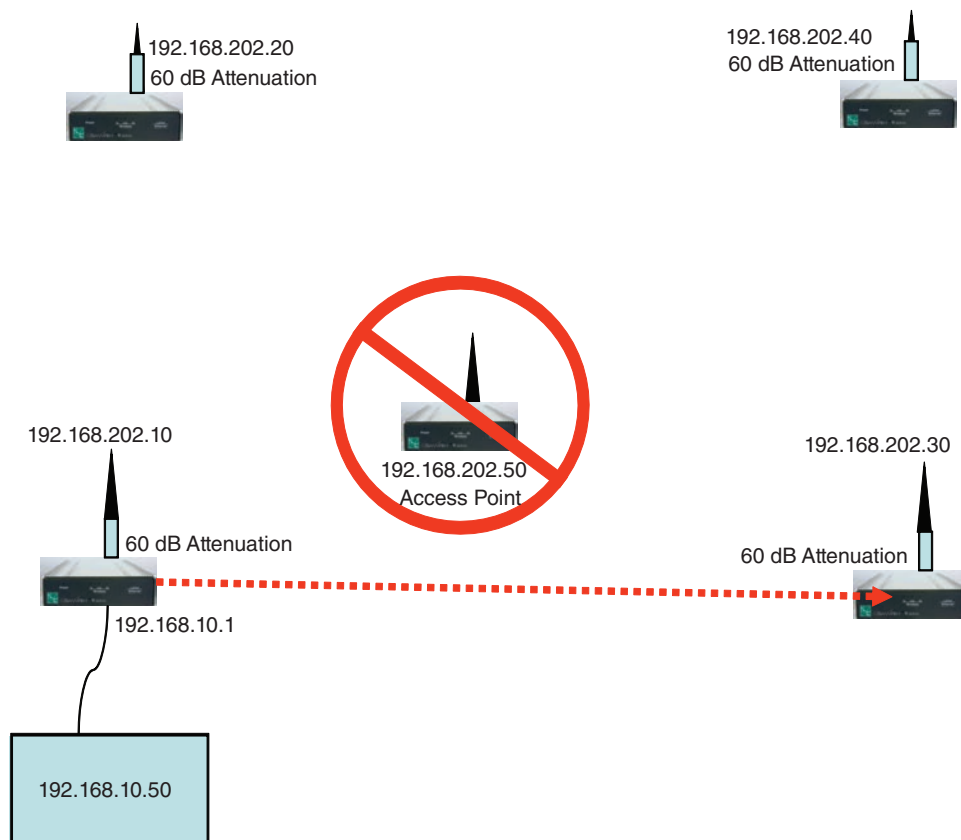

**Figure 45. Point-to-multipoint network.**

## Point-to-Multipoint Network

**STEP 5.** See Figure 46. Restore power to the access point (Radio #50).

**STEP 6.** Observe the results from running the following commands: C:\ping 192.168.202.30 -t -w 0 and C:\>tracert 192.168.30.1.

Trace the route to 192.168.202.30 over a maximum of 30 hops.

```
1 * * * Request timed out
2. 11 ms 18 ms 18 ms 102.168.202.50
3. 11 ms 18 ms 18 ms 102.168.202.30
```

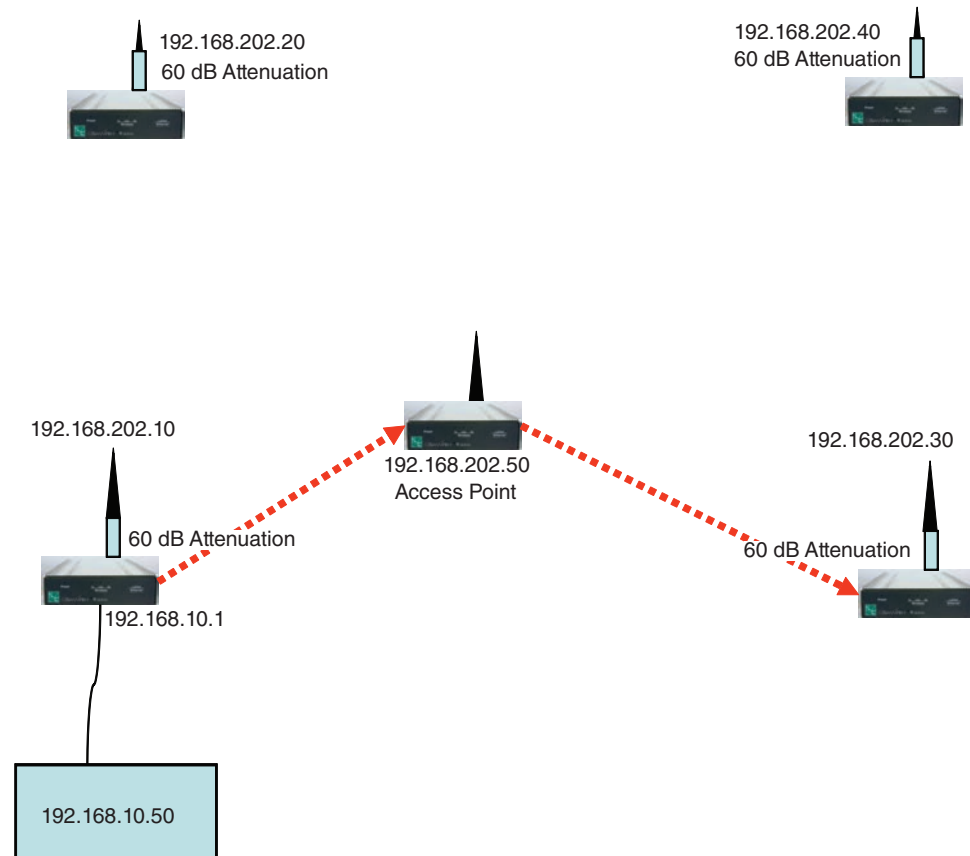

Figure 46. Point-to-multipoint network.

Follow these steps to test route optimization:

**STEP 1.** Reconfigure all the radios, as shown in Figure 47.

**STEP 2.** Reboot all the radios.

**STEP 3.** Observe the results from running the following commands: C:\ping 192.168.202.30 -t and C:\>tracert 192.168.202.30.

Trace the route to 192.168.202.30 over a maximum of 30 hops.

```
1 * * * Request timed out
2. 11 ms 18 ms 18 ms 192.168.202.50
3. 24 ms 24 ms 29 ms 192.168.202.30
```

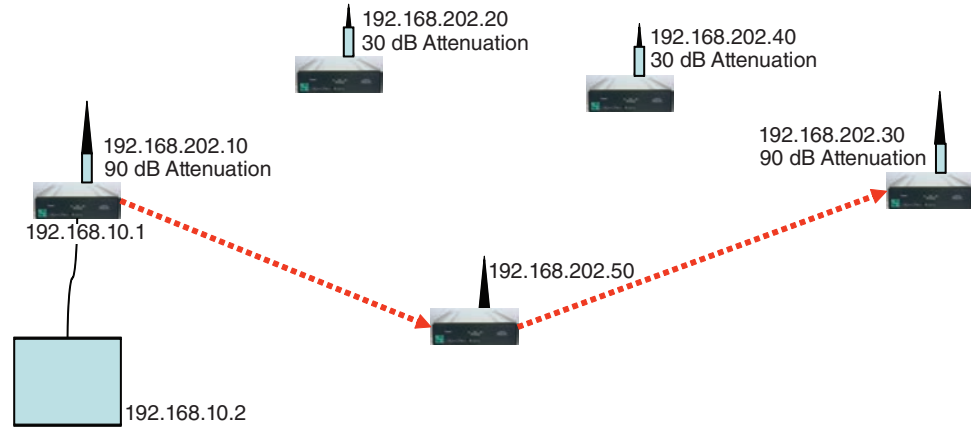

Figure 47. Testing five-node route optimization.

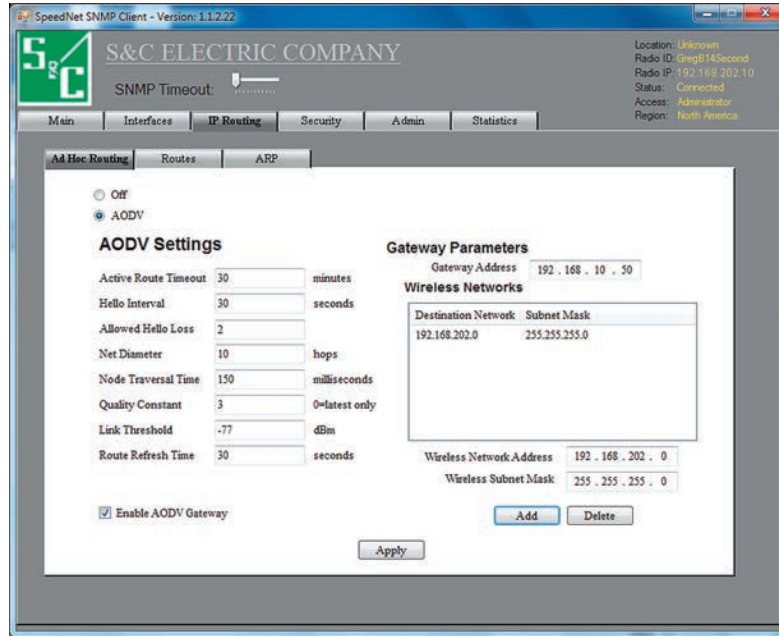

Figure 48. AODV configuration screen.

Follow these steps to create an AODV gateway:

- STEP 1.** On the *Main* screen, select the **IP Routing** tab, and open the *AODV Settings* screen. See Figure 48.
- STEP 2.** Enable the AODV Gateway.
- STEP 3.** Enter Default Gateway Address, 192.168.10.50.
- STEP 4.** Add SpeedNet Network Address, 192.168.202.0.
- STEP 5.** Apply settings. See Figure 49.

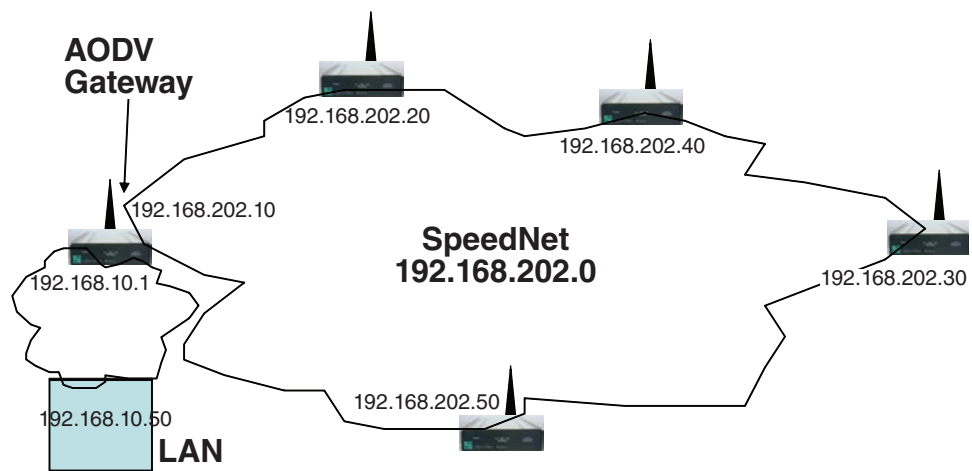

Figure 49. AODV gateway illustration.

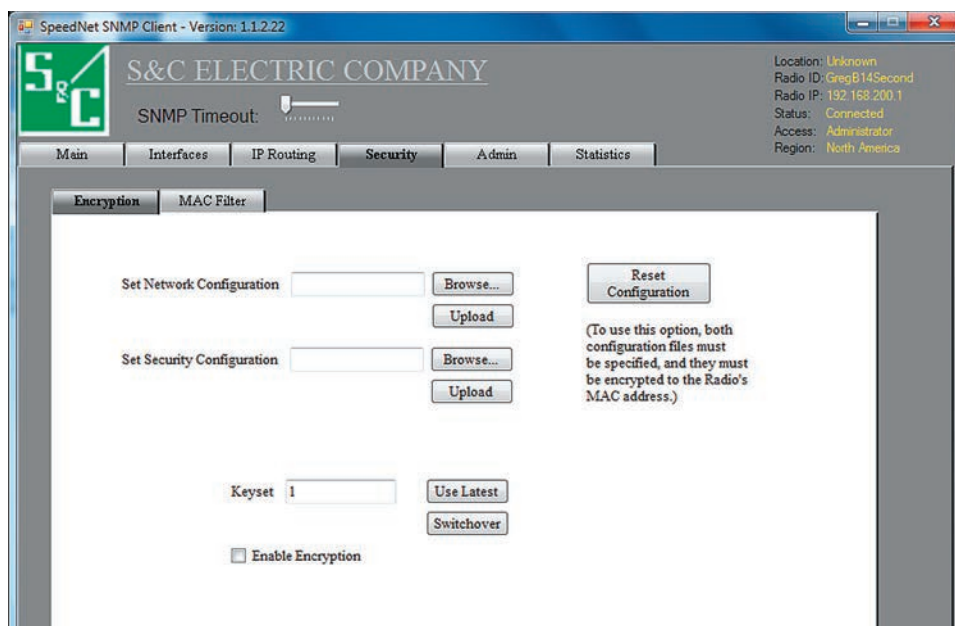

Figure 50. Security and encryption configuration window.

When enabling encryption, make sure to start with the furthest node out and work your way back to the Gateway radio.

SpeedNet Radios only encrypt at the source and decrypt at the destination. This is accomplished by tunneling, so nodes that are part of the route do not decrypt. This mitigates latency due to encryption. See Figure 50.

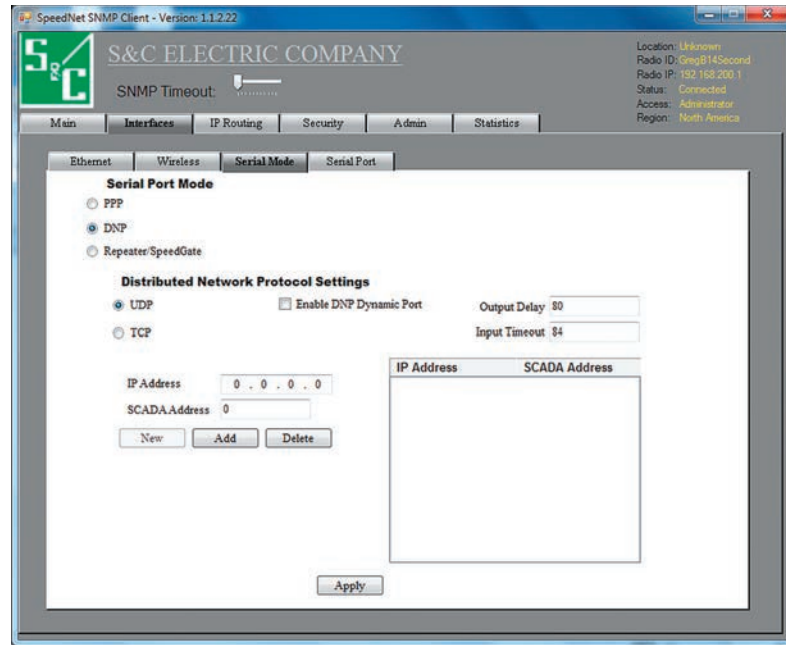

Figure 51. Serial Port Mode and DNP Settings configuration window.

The Serial Mode wraps Serial DNP data in a UDP Packet. See Figure 51. Follow these steps to enable Serial Mode:

- STEP 1.** Enable DNP and click on the **Apply** button.
- STEP 2.** Enable UDP and DNP Dynamic Port.
- STEP 3.** Add the DNP/IP address to the lookup table; use the radio wireless IP address.
- STEP 4.** Click on the **Apply** button.



Figure 52. Serial port configuration window.

The serial port can be configured for Baud Rate, Data Bits, Parity, Stop Bits, and Flow Control. See Figure 52.