

This document provides specifications for the Vista Underground Distribution Switchgear voltage-sensing circuit. The voltage-sensing circuit consists of three parts: a capacitive tap molded inside the bushing or bushing well, a tank-mounted voltage signal amplifier, and a voltage output card in the Vista switchgear's electronics

rack located inside the low-voltage enclosure. The voltage indicator (option suffix “-L1” or “-L2”) also receives its inputs from the voltage signal amplifier. A 5-Vac output is standard, but a 69-Vac output is available using the high-voltage output card in place of the standard voltage output card in the Vista switchgear electronics rack.

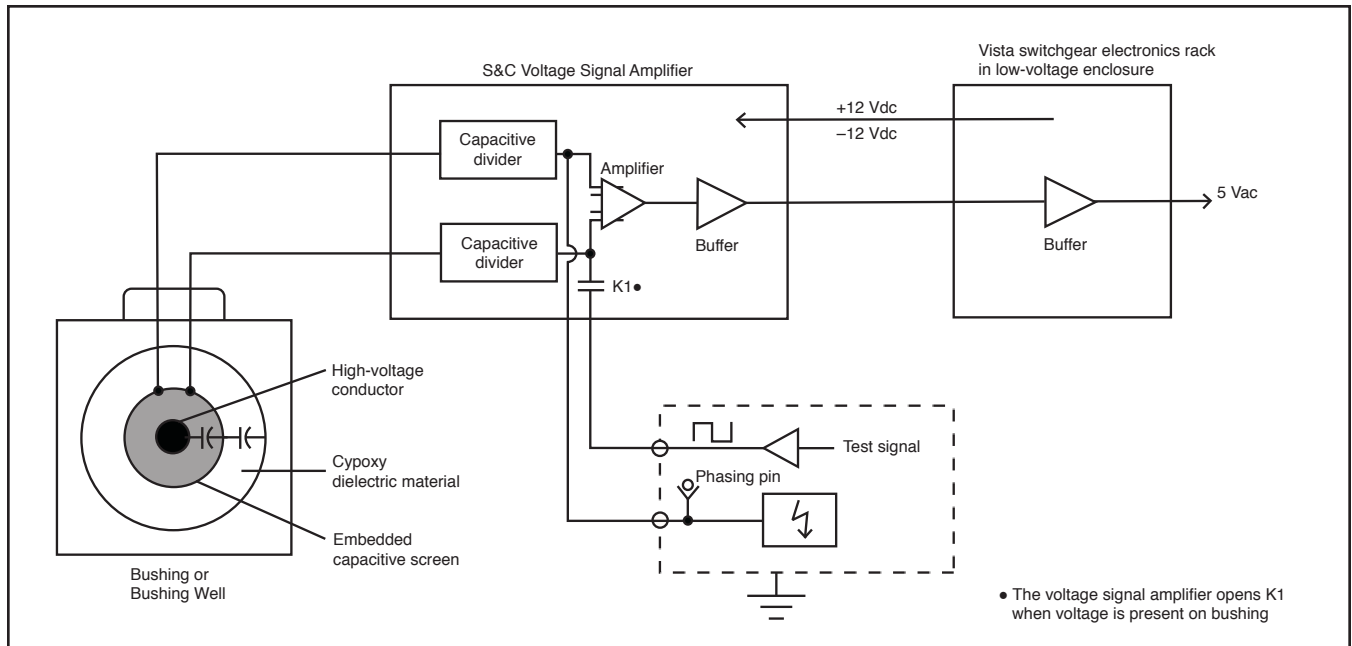

Figure 1. Schematic of a Vista switchgear voltage-sensing circuit.

Table 1. Input Ratings And Physical Characteristics

Voltage, kV		
Max	Operating Range <sup>①</sup>	Impulse Withstand (BIL)
15.5	11.43 to 15.5	95
29	20.44 to 29	125
38	28.3 to 38	150

<sup>①</sup> For lower system voltages, consult the nearest S&C Sales Office.

Table 2. Output Ratings

Voltage, Vac	Power, VA	Voltage Ratio, Nominal <sup>①</sup>			Phase-Angle, Nominal	Accuracy <sup>②</sup>	
		14.4 kV	25 kV	34.5 kV		Magnitude	Phase Angle
5	0.001	1656:1	2926:1	4071:1	3° leading	±3.0%	±1.0°
69	0.05	120:1	212:1	295:1	3° leading	±3.0%	±1.0°

<sup>①</sup> The voltage ratios are nominal. As there is variance in analog input impedance, user calibration of the voltage sensor is required.

<sup>②</sup> The accuracies shown are in percent of reading and reflect user calibration of the voltage-sensor output using the precise magnitude

ratio and phase-angle shift appropriate for each sensor, and they are applicable over the operating temperature range listed and under all weather conditions.



Supersedes Data Sheet 682-93 dated 12-21-09.

June 1, 2020

© S&C Electric Company 2002-2020, all rights reserved