

This information bulletin contains specifications for S&C Current Sensors and S&C Voltage Sensors furnished as part of the control equipment group for S&C Remote Supervisory Pad-Mounted Gear or as an optional feature or accessory for Type PM Switch Operators for a field retrofit. These specifications are especially useful when the sensors are used in applications where the RTU is supplied by others.

Remote Supervisory PMH or PME Pad-Mounted Gear can be furnished with a control equipment group that includes field-installed S&C Current Sensors for three-phase current sensing. An integral S&C Voltage Sensor may also be included for single-phase voltage sensing and/or control-power input to a battery charger and battery packs for powering the switch operators mounted on the gear.

When the voltage sensor is used for voltage sensing, additional voltage sensors for three-phase voltage sensing are available as an option. Type PM Switch Operators can be specified with a single field-installed S&C Voltage Sensor for control-power input to a battery charger and battery packs for powering one or more switch operators.

S&C Current Sensors are available as an accessory. In applications where S&C does not furnish the remote terminal unit (RTU) and the voltage sensor is used to provide control-power input to a battery charger and battery packs, the voltage sensor cannot be used for voltage sensing and cannot be used to power any user-supplied equipment.

S&C Current Sensors are of a split-core closed-gap design with uniformly distributed windings protected by a black semiconductive coating and are designed for

customer installation on the cables of power-operated Mini-Rupter® Switches. Because these current sensors are of a saturating type, shorting switches are not required. The current sensors have an output current ratio of 600:5 and can drive conventional current transducers.

Note: The output of the sensor at primary currents in excess of 2000 amperes RMS is a distorted waveform that may affect the performance of certain fault detection schemes. See Figure 2 on page 3.

S&C Voltage Sensors are of molded Cypoxy™ Insulator construction and are constant-current output devices similar to current transformers. Primary fusing—as required by voltage transformers—is therefore eliminated.

User-selectable burdens are included on the switch control in the switch operator to provide either a 5-Vac output or 69-Vac output. A voltage limiter is also included in the switch operator to protect the voltage sensors in the event the secondary circuit is inadvertently opened or the burden is removed.

The voltage sensors furnished in remote supervisory pad-mounted gear serve as support insulators for the switch live parts—thereby eliminating the complexity and space requirements associated with voltage transformers. For PM Switch Operators for a field retrofit, the optional voltage sensor is mounted on a bracket for installation by the user in the switch compartment of the pad-mounted gear.

Typical amplification factors for voltage sensors up to the 17th harmonic are provided in Figures 4 and 5 on page 6. The current sensor response is essentially flat for all harmonics, therefore, no correction of secondary current harmonic measurements is required.



Type PM Switch Operators

Current Sensor

Type: Saturating split-core closed-gapped

Operating Temperature Range: -40°C (-40°F) to +40°C (+104°F)

Table 1. Input Ratings

Current, Amperes		Voltage, kV
Nominal	Saturation	
600	2000	●

● The split-core current sensor is applicable to all voltage classes of remote supervisory pad-mounted gear.

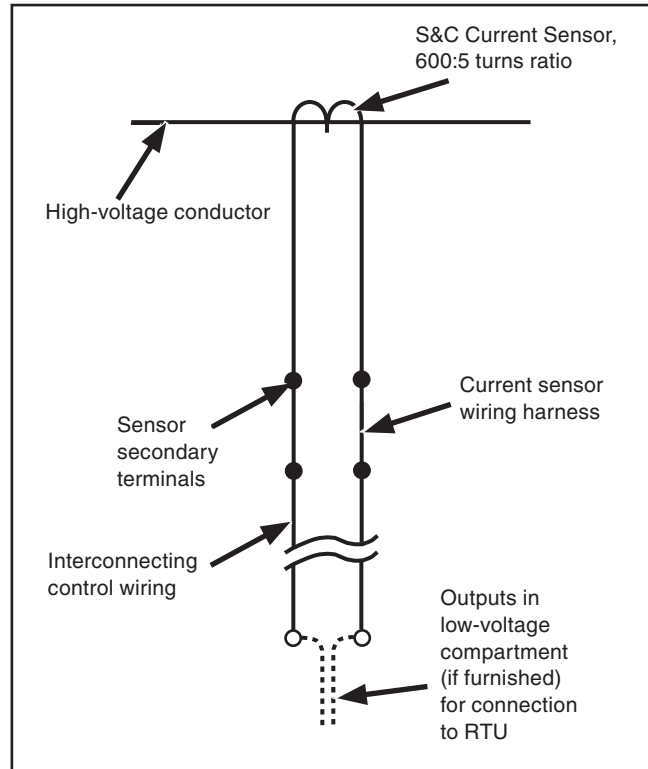

Figure 1. Schematic of an S&C Current Sensor.

Table 2. Current Sensor Output Ratings

Current, Nominal, Amperes ac	Power, Nominal, VA ^①	Open Circuit Voltage, Vac ^②		Current Ratio, Nominal	Phase Angle Shift, Nominal	Accuracy ^③ , for Primary Currents from			
		At 900 Amperes	At 12,500 Amperes			60 to 200 Amperes		200 to 900 Amperes	
						Magnitude	Phase Angle	Magnitude	Phase Angle
5.0	5.0	40	300	120:1	1.0° leading	+/- 1.5%	+/- 1.5°	+/- 1.0%	+/- 1.0°

① Measured at the secondary terminals of the sensor. The combined burden of user-supplied equipment (transducers, RTU, etc.) connected to the current sensor output terminals (in the low-voltage compartment, if furnished) must be less than 1.0 volt-ampere.

② Open circuit voltage is expressed as the RMS value of a sine wave having the same peak voltage as the open circuited current sensor.

③ Accuracies shown are in percent of reading and reflect user calibration of the current sensor output using the precise magnitude ratio and phase angle shift appropriate for each sensor, and are applicable over the operating temperature range listed and under all

weather conditions. The precise magnitude ratio and phase angle shift for each current sensor are marked on the current sensor and, when the sensor was installed, should also have been written on the yellow card included in the Installation and Operation Information Kit provided with the remote supervisory pad-mounted gear or PM Switch Operator. The accuracies are +/- 5% for magnitude and +/- 4° for phase angle if the current sensor outputs are calibrated using the nominal magnitude ratio and phase angle shift. To develop overall system accuracy, additional tolerances must be added to reflect user-supplied equipment.

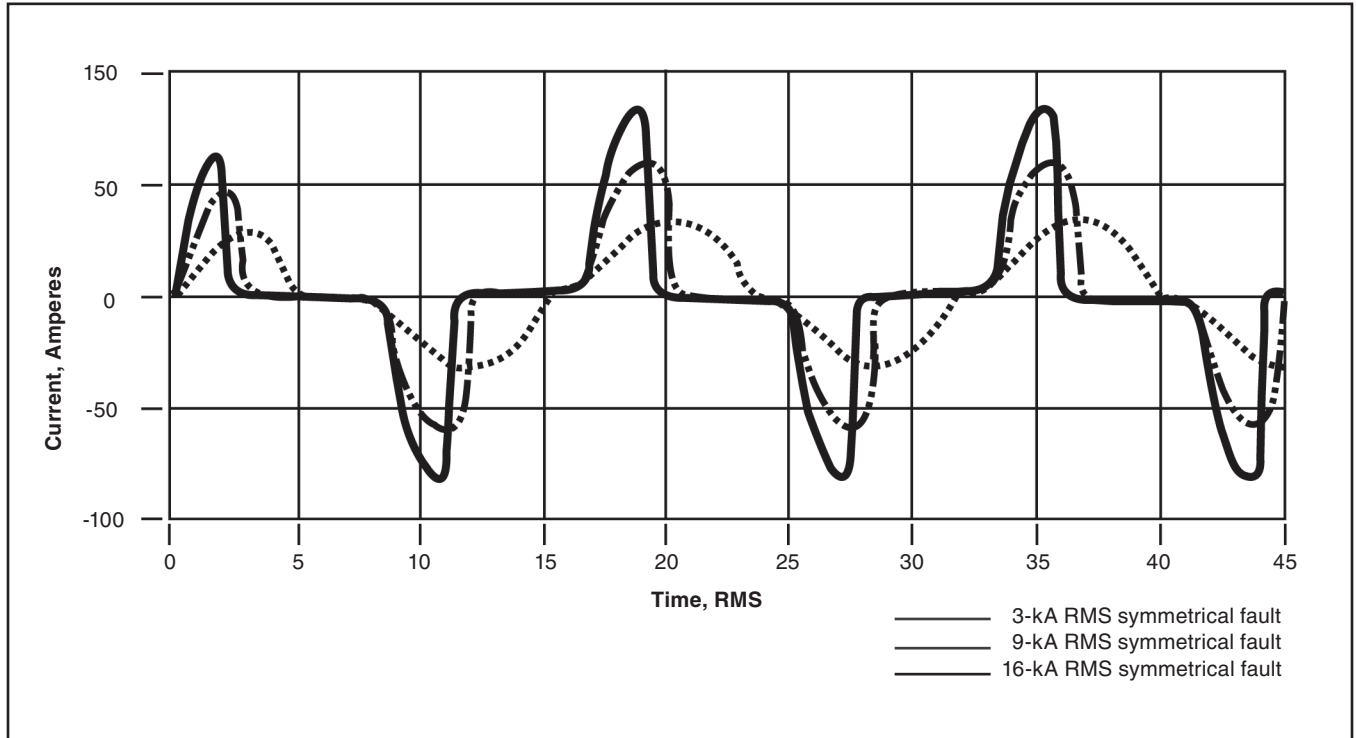

Figure 2. Output waveforms of a saturated current sensor (with maximum allowable burden).

Type PM Switch Operators

Voltage Sensors

Type: High-voltage capacitor series connected to dry-type transformer

Surge Protection: Internal gas-filled spark gap

Operating Temperature Range: -40°C (-40°F) to +40°C (+104°F)

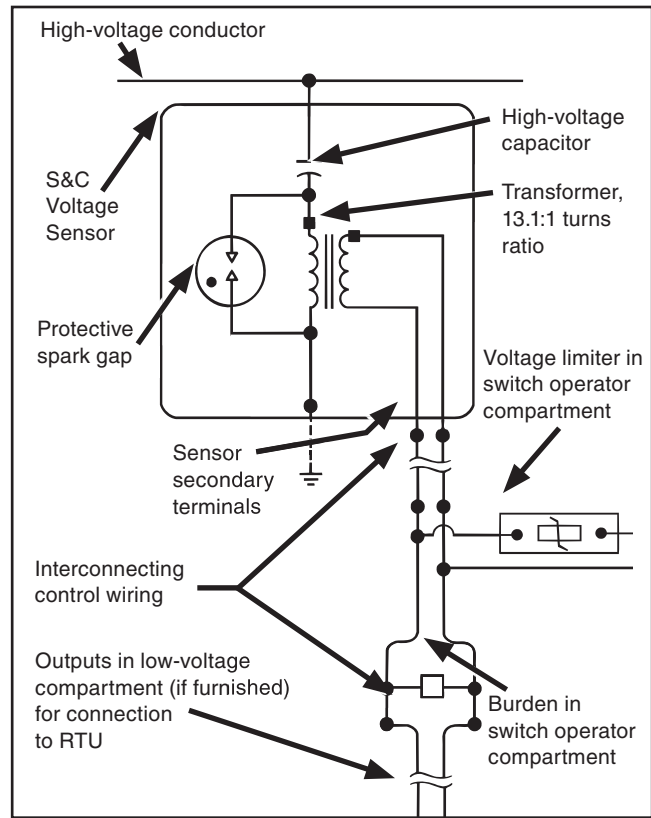

Figure 3. Schematic of an S&C Voltage Sensor.

Table 3. Voltage Sensor Input Ratings and Physical Characteristics

Voltage, kV		Impulse Withstand (BIL)	60-Hz Withstand	Leakage Distance, Inches (mm)	Dry Arcing Distance, Inches (mm)
Nominal	Operating Range ^①				
14.4	11.43 to 17.0	110	36	11¾ (30)	6¼ (16)
25	20.44 to 29	150	60	18 (46)	7½ (19)

① For lower system voltages, consult the nearest S&C Sales Office.

Table 4. Voltage Sensor Output Ratings

Voltage, Vac		Power, Nominal, VA ^③	Voltage Ratio, Nominal		Phase-Angle Shift, Nominal	Accuracy ^④	
Nominal ^①	Open Circuit ^②		14.4 kV	25 kV		Magnitude	Phase Angle
5	220	1.0	1386:1	2440:1	88.0° leading	+/- 1.0%	+/- 1.0°
69	220	11.5	126:1	212:1	1.0° leading	+/- 3.0%	+/- 1.0°

① The S&C Switch Control includes user-selectable 33.2-ohm and 6.5 µf (408-ohm equivalent) burdens are furnished to provide 5-Vac or 69-Vac outputs, respectively. **Note:** The nominal outputs listed do not precisely correspond to the nominal input rating.

② Open circuit voltage is expressed as the RMS value of a sine wave having the same peak voltage as the open-circuited voltage sensor (with the voltage limiter in place).

③ Measured across the voltage sensor burden on the switch control. The combined burden of user-supplied equipment (transducers, RTU, etc.) connected to the voltage sensor output terminals (at the switch control in the switch operator or in the low-voltage compartment if furnished) must be less than 0.001 volt-amperes for the 5-Vac output and 2.5 volt-amperes for the 69-Vac output. Additional burden will affect the accuracies published herein.

④ Accuracies shown are in percent of reading and reflect user calibration of the voltage sensor output using the precise magnitude ratio and phase angle shift appropriate for each sensor, and are applicable over the operating temperature range listed and under all weather conditions. The precise magnitude ratio and phase angle shift for each voltage sensor are marked on the voltage sensor and, for remote supervisory pad-mounted gear are also written on the yellow card included in the Installation and Operation Information Kit provided with the gear. To develop overall system accuracy, additional tolerances must be added to reflect user-supplied equipment.



Figure 4. Amplification factor versus the order of harmonic for a 5-Vac nominal voltage sensing output at 25°C (77°F). Applicable to S&C Voltage Sensors of all ratings.

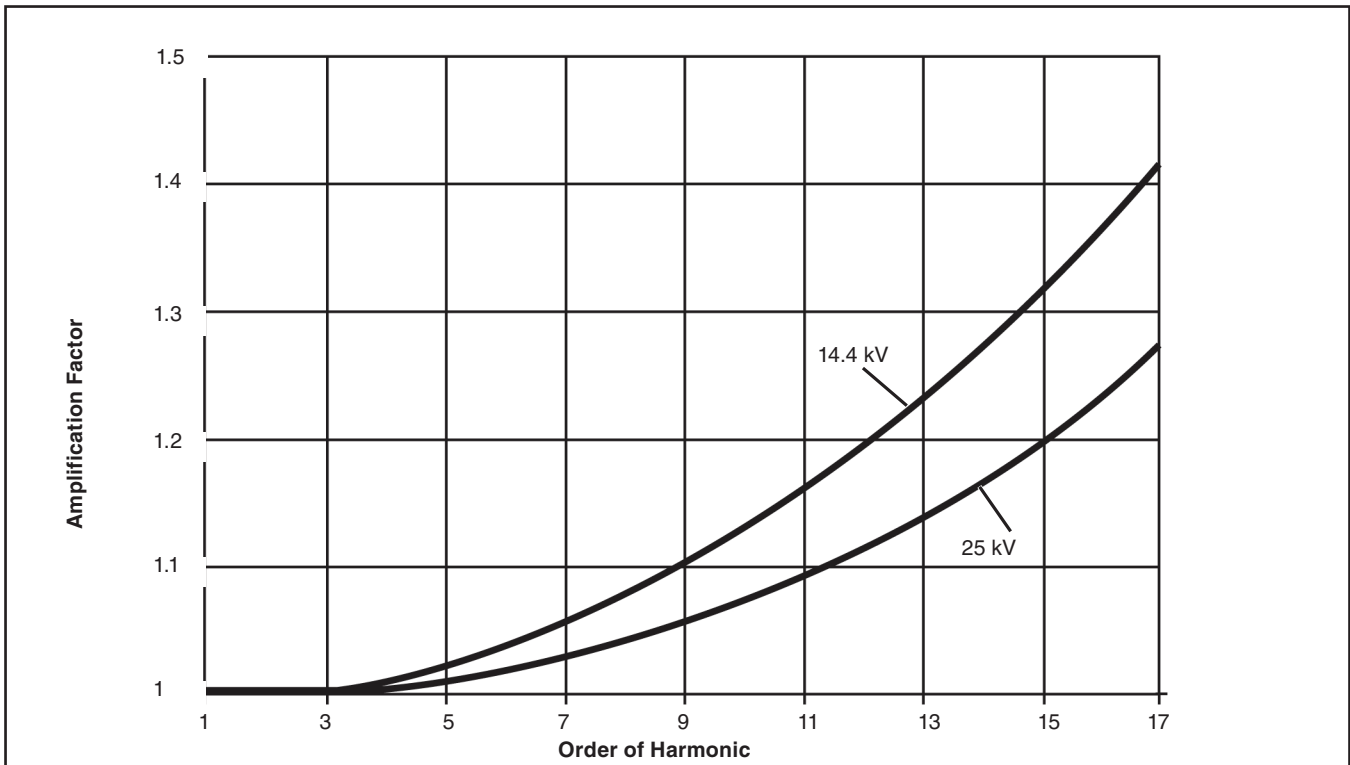

Figure 5. Amplification factor versus the order of harmonic for a 69-Vac nominal voltage sensing output at 25°C (77°F). Applicable to S&C Voltage Sensors of all ratings shown.