

Design Requirements for Structures or Pedestals to Support Circuit-Switchers

The Mark V Circuit-Switcher's high operating speed (total blade-travel time of 1.25 to 1.5 seconds) produces high acceleration and deceleration rates, resulting in high dynamic forces—which are transferred to the supporting structures (or pedestals) and adjoining bus.

Supporting structures (or pedestals) must be designed to support dead weight and to minimize deflections from bending moments. Structures (or pedestals) should limit deflections as follows:

1. Maximum deflection, under dynamic forces, of any supporting member of the circuit-switcher should not exceed $\frac{3}{8}$ inch (9.5 mm) in any direction.
2. Similarly, the deflection under static wind load should not exceed one inch (24.5 mm).
3. The rotational deflection of the switch-operator support in resisting the switch-operator locked-rotor torque of 21,500 inch-pounds should not exceed 5.0 degrees.

For purposes of supporting-structure design, it is assumed dynamic forces and static wind loads do not occur simultaneously. Generally, the bending moments produced by dynamic forces will dictate the design of the structure and the foundation. Forces produced by wind loads must be considered in the case of high structures, as these static bending moments may exceed the dynamic moments.

M_{wt} and M_{wl} (see page 2) are the wind moments in the transverse and longitudinal directions, respectively,

at each circuit-switcher pole-unit. F_{wt} and F_{wl} are the wind forces in the transverse and longitudinal directions, respectively, at each circuit-switcher pole-unit. For the most common mounting arrangement, in which the mounting-frame weldment is supported by a single pedestal of height "B," the maximum bending moment at the foundation may be found as follows:

Transverse: $3M_{wt} + (3F_{wt} \times B) +$ (Bending moment from wind acting on pedestal)

Longitudinal: $3M_{wl} + (3F_{wl} \times B) +$ (Bending moment from wind acting on pedestal)

F_c and F_o appear as forces at the circuit-switcher terminal pads accompanying closing and opening operations. F_c is a direct compression force resulting from closing of the circuit-switcher. F_o is a shear force parallel to the pole-unit centerline. M_o is a turning moment tending to rotate the pole-unit in a counter-clockwise direction as viewed in the elevation drawing on page 2. Limiting deflections of the circuit-switcher supporting members to recommended values will ensure these forces will be absorbed by the pedestals and not transferred to adjoining bus or other apparatus (e.g., bushings). Use of expansion joints at circuit-switcher terminal pads will compensate for inherent insulator-column deflection.

The weight of the bus plus any associated ice load exerts a vertical force on the circuit-switcher terminal pads. This vertical force must not exceed 400 pounds (181 kg) at any terminal pad.

★ Information given in this publication applies to equivalent models of Mark IV Circuit-Switchers.



Upright Mounting

In these loading diagrams, no attempt has been made to indicate a specific arrangement of the supporting structure, because there are many ways it can be executed. However, the values shown provide complete loading data. (Steel pedestals are available from S&C which meet the requirements outlined here.)

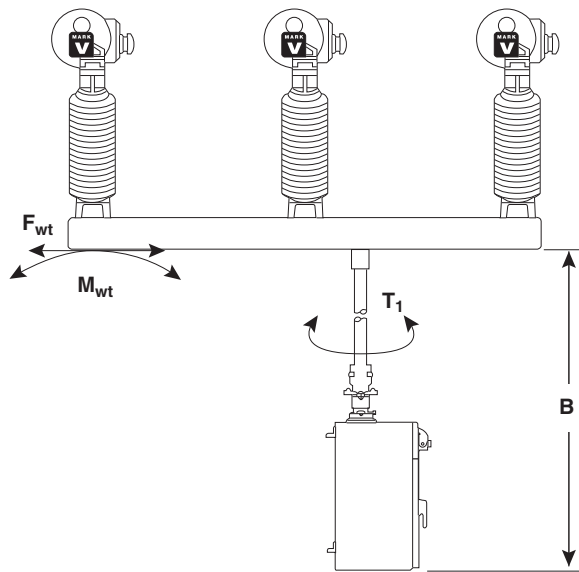

Maximum vertical force from weight of bus plus any ice load not to exceed 400 pounds (181 kg.) at any terminal pad

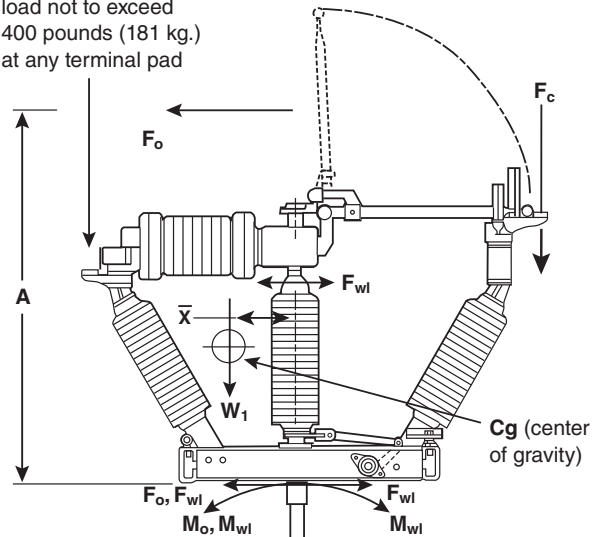

Legend:

- A** Moment arm for force F_o
- B** Height of mounting pedestal or supporting structure
- Cg** Center of gravity
- F_c** Dynamic force accompanying closing operation
- F_o** Dynamic force accompanying opening operation
- F_{wl}** Static wind force, longitudinal
- F_{wt}** Static wind force, transverse
- M_o** Dynamic bending moment ($= F_o \times A$)
- M_{wl}** Static wind bending moment, longitudinal
- M_{wt}** Static wind bending moment, transverse
- T_1** Switch-operator locked-rotor torque
- T_2** Torque delivered to interphase shaft
- W_1** Weight of one circuit-switcher pole-unit
- W_2** Weight of switch operator
- \bar{X}** Horizontal distance from centerline of center rotating insulator stack to center of gravity

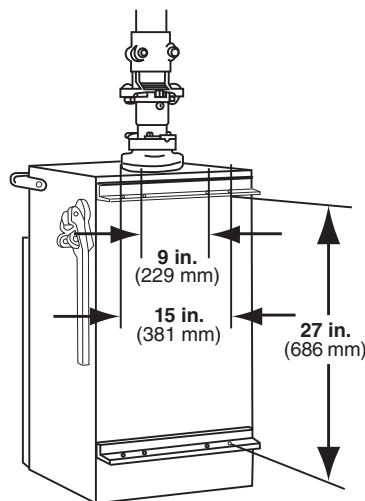

Switch operator mounting-hole spacing

Table 1. Loading Data^①

Rating, kV	F _c , Lbs. ②	F _o , Lbs. ②	F _{wl} , Lbs. ②	F _{wl} , Lbs. ②	M _o , In-Lbs. ②	M _{wl} , In-Lbs. ②	M _{wl} , In-Lbs. ②	T ₁ , In-Lbs.	W ₁ , Lbs. (kg.) ②	W ₂ , Lbs. (kg.)	A, Inches (mm)	X̄, Inches (mm)
34.5	130	115	180	460	7 800	3685	9 950	21 500	2250 (1021)	350 (159)	68 (1727)	4 (102)
46	140	125	190	500	9 400	4185	11 600	21 500	3040 (1379)	350 (159)	75 (1905)	5 ³ / ₈ (137)
69	225	200	235	610	17 600	5700	16 700	21 500	3330 (1510)	350 (159)	88 (2235)	3 ¹ / ₄ (83)

① Values shown are for circuit-switchers equipped with: (a) station post insulators, (b) the maximum number of interrupting gaps, and (c) Type CS-1A Switch Operator. Wind force is based on 100-mph wind velocity.

② Per circuit-switcher pole-unit.