

S&C Type PM Switch Operators provide power operation of the associated Mini-Rupter® Switch in response to a remote or local-pushbutton signal. Type PM Switch Operators are furnished for field retrofit on installed models of S&C Pad-Mounted Gear, or are factory-installed on S&C Remote Supervisory Pad-Mounted Gear.

When purchased for field retrofit, one switch operator on each unit of pad-mounted gear being retrofitted must be equipped to supply control power to all switch operators on that unit. Optionally, control power can be provided by two series-connected 12-volt, 5 ampere-hour battery packs that are charged by an S&C-designed and manufactured constant-voltage battery charger. The optional battery charger requires a 120-volt ac input which is provided either from an external user-supplied power source or from an internal S&C-supplied power source (voltage sensor). The optional voltage sensor provides a 20-volt-ampere, 120-volt, 60-hertz voltage source for input to the battery charger. For field retrofit applications, the voltage sensor is available only for PMH and PMS models.

For switch operators that are factory-installed on S&C Remote Supervisory Pad-Mounted Gear, the source of control power is determined by the control equipment group that is specified with the particular unit of pad-mounted gear. Depending on the control equipment group specified, one switch operator on each unit of pad-mounted gear may include an S&C Battery Charger with

battery packs (as described above for field retrofit switch operators). Similarly, the 120-volt ac input to the battery charger may be provided by an S&C Voltage Sensor.

When furnished, the S&C Battery Charger and battery packs provide control power for operation of all switch operators as well as for the remote terminal unit and applicable transceivers, if specified. The battery charger features dual 12-volt dc outputs to provide control power when the ac source is present. Upon loss of ac source, the battery packs—if fully charged—will provide control power for the operating times shown on page 2. When the RTU and associated equipment are supplied by others, the battery charger and battery packs only provide power to the switch operators and are not intended to supply power to any user-furnished equipment.

The battery charger is fully temperature compensated and features an integral load-disconnect circuit to prevent deep-discharge of the batteries on loss of ac source. It also includes an alarm circuit to indicate loss of ac source (field selectable), battery low-voltage, or charger overvoltage.

The battery packs are manufactured by Hawker Energy Products, and the batteries are of starved-electrolyte sealed-lead construction.

Following are specifications for the battery charger and for the battery packs.

S&C Battery Charger

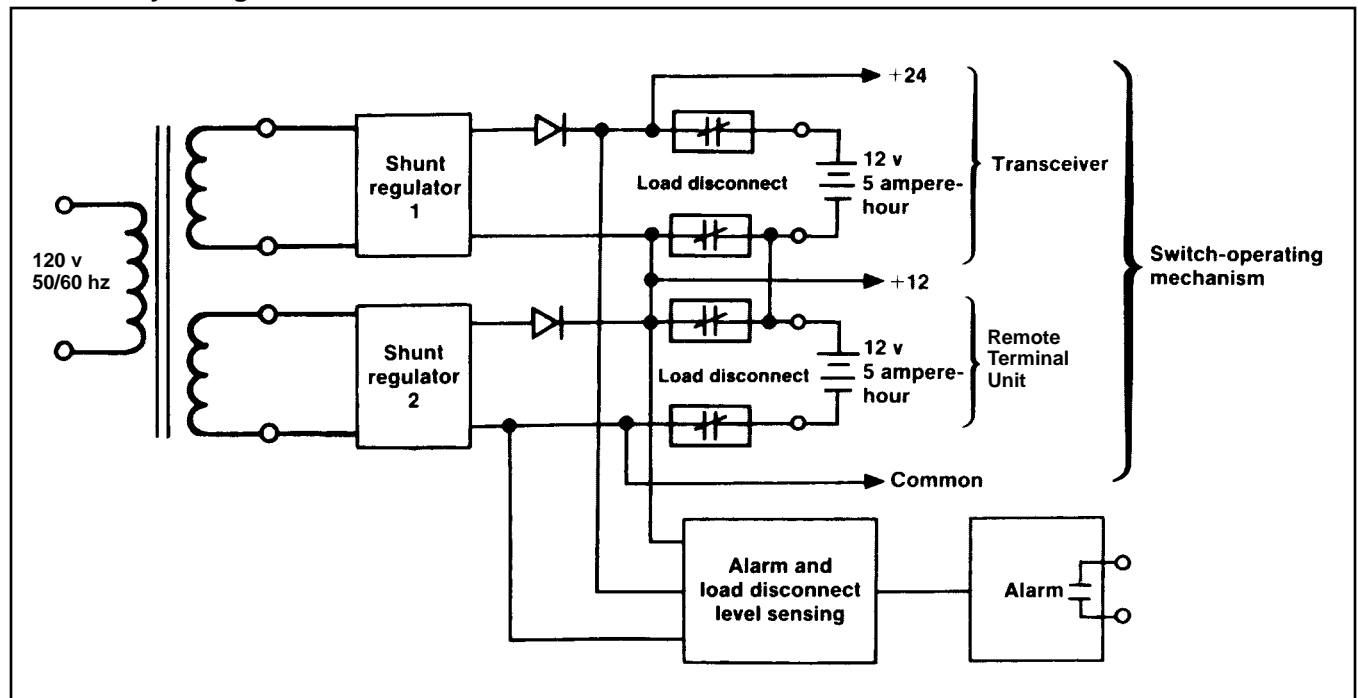

S&C Battery Charger

Manufacturer S&C Electric Company
Type Constant-Voltage Temperature Compensated
Operating Temperature Range -40°C to +70°C
Input Voltage 120 volts, 50/60 Hz
Number of Battery Charging Outputs 2
Float Charge Voltage 13.5 volts at +25°C
Low-Voltage Load Disconnect 11.8 volts at +25°C
Low-Voltage Alarm-Contact Opening 12.1 volts at +25°C
Charger Overvoltage Alarm-Contact Opening 15.5 volts
at +25°C

Loss of Ac Source Alarm◆
(Field Selectable, Shipped Disabled) 0.0 volts
Maximum Time to Recharge Battery Packs
Upon Return of Ac Source 24 hours
Dc Output Fuse Type 3 AG, 10 A
Ac Input Fuse Type 3 AG, 3/8 A

Monobloc Battery Packs in Plastic Outer Case

Manufacturer Hawker Energy Products
Type Rechargeable, sealed-lead, starved-electrolyte
Part Number 0809-0016 (S&C # 9931-267)
Number of Packs Required 2
Nominal Voltage (each battery pack) 12 volts dc
at +25°C
Rated Capacity (10-Hour Rate) 5 ampere-hour
at +25°C

Operating Temperature Range -40°C to +40°C
Life Expectancy★ 2-6 years
Maximum Recommended Interval
Between Charge 6 months
Deep Discharge Limit (12-volt pack) 10.2 volts
Deep Discharge Limit (24-volt pack) 21.6 volts
Maximum Storage Temperature +40°C

Operating Time▲ (when disconnected from ac source)
For 1-Watt Radio at -40°C 7 hours
For 1-Watt Radio at +25°C 13 hours
For 5-Watt Radio at -40°C 4 hours
For 5-Watt Radio at +25°C 9 hours

- ◆ To enable loss of ac source alarm, remove cover from battery charger and move jumper in upper left-hand corner from position "W1" to "W2."
- ★ Dependent on storage conditions, charger settings, temperature, and type of load.
- ▲ The values shown represent the approximate length of time that S&C Automated Switching Systems will function before the low-voltage load-disconnect circuit in the battery charger operates to prevent deep discharge of the battery packs. These time values are based on continuous operation of the RTU drawing 3 watts, and occasional recharging of the switch-operating mechanism.