

CONFIDENTIAL: This document contains confidential information of S&C Electric Canada Ltd. It is intended solely for internal use. Such confidential information may not be emailed, posted, used, reproduced, or disclosed to any other parties for any other purpose without the express written permission of S&C Electric Canada Ltd.

April 8, 2020

This week marks our first week with the strengthened weekend shift. This decision made assembly areas less dense and hence, social distancing was easier to achieve in those areas. In my perspective, this fortified weekend shift appears to be helping with social distancing for both day and afternoon shifts. If you have ideas for improvement, I strongly encourage team members to please bring it up with their leadership team. We are always open to “tweaking” the plan. If we all work together, I am confident we can find a formula that will provide a safer work environment and still meet our customer’s demands.

Some team members asked me about the use of masks. S&C Canada is closely monitoring the position of both the World Health Organization (WHO) and Canada’s Chief Public Health Officer, Dr. Theresa Tam, with respect to the use of masks. Dr. Theresa Tam recently stated that Canadians can use a non-medical mask (e.g. home-made face coverings) to help stop the spread of COVID-19. Wearing a mask is an added layer of protection that can help prevent pre-symptomatic and asymptomatic people from inadvertently infecting others with COVID-19. However, she advised that the use of non-medical masks should be applied in connection with other preventative measures, including social distancing measures and staying at home, to limit the transmission of the COVID-19 virus. S&C Canada would like to add the following measures which include frequent hand-washing and staying at home if you or someone you are in close contact with is sick.

- As per the CDC, if you are healthy, masks are effective only when used in combination with frequent hand-cleaning with alcohol-based hand rub or soap and water. If you wear a mask, then you must know how to use it and dispose of it properly.
 - Before putting on a mask, clean hands with alcohol-based hand rub or soap and water.
 - Cover mouth and nose with mask and make sure there are no gaps between your face and the mask.
 - Avoid touching the mask while using it; if you do, clean your hands with alcohol-based hand rub or soap and water.
 - Replace the mask with a new one as soon as it is damp and do not re-use single-use masks.
 - To remove the mask: remove it from behind (do not touch the front of mask); discard immediately; clean hands with alcohol-based hand rub or soap and water.

Furthermore, S&C Canada is working to procure masks. If you have a personal mask, either purchased or homemade, please feel free to wear it at work. If you would like to make your own mask, attached is a document outlining three different “do-it-yourself” mask designs. As you can imagine, obtaining enough disposable masks for the entire S&C Canada population is proving challenging during these times, but I am confident our Supply Chain team will be successful in short order.

We presently have 9 Canadian team members out due to illness, travel and family; down from last week’s announcement of 18 team members. To-date, no team members have tested positive for COVID-19. Human Resources (HR) have been diligent in monitoring these team members over the course of their quarantine and clearing them when it is safe to return to work. **If you are feeling ill or have been in contact with an individual who may have the COVID-19 virus or is experiencing any sickness, please do not come to work and continue to follow HR guidelines and reach out to HRHelp@sandc.com**

If you have not already done so, please sign up to S&C Canada’s a private Instagram page at: **sccanadaupdates** to receive the latest updates on what is happening at S&C Canada.

I would like to wish you all a wonderful long weekend. Please stay safe. During these times, it is customary to spend time with family. I encourage you to please stay home and phone your loved ones. **Let’s all work together to stop the spread of COVID-19.**

Sincerely



Angelo Gravina

Attch.

Use of Cloth Face Coverings to Help Slow the Spread of COVID-19

How to Wear Cloth Face Coverings

Cloth face coverings should—

- fit snugly but comfortably against the side of the face
- be secured with ties or ear loops
- include multiple layers of fabric
- allow for breathing without restriction
- be able to be laundered and machine dried without damage or change to shape

CDC on Homemade Cloth Face Coverings

CDC recommends wearing cloth face coverings in public settings where other social distancing measures are difficult to maintain (e.g., grocery stores and pharmacies), **especially** in areas of significant community-based transmission.

CDC also advises the use of simple cloth face coverings to slow the spread of the virus and help people who may have the virus and do not know it from transmitting it to others. Cloth face coverings fashioned from household items or made at home from common materials at low cost can be used as an additional, voluntary public health measure.

Cloth face coverings should not be placed on young children under age 2, anyone who has trouble breathing, or is unconscious, incapacitated or otherwise unable to remove the cloth face covering without assistance.

The cloth face coverings recommended are not surgical masks or N-95 respirators. Those are critical supplies that must continue to be reserved for healthcare workers and other medical first responders, as recommended by current CDC guidance.

Should cloth face coverings be washed or otherwise cleaned regularly? How regularly?

Yes. They should be routinely washed depending on the frequency of use.

How does one safely sterilize/clean a cloth face covering?

A washing machine should suffice in properly washing a cloth face covering.

How does one safely remove a used cloth face covering?

Individuals should be careful not to touch their eyes, nose, and mouth when removing their cloth face covering and wash hands immediately after removing.



CS316353B 04/04/2020, 12:22 PM

[cdc.gov/coronavirus](https://www.cdc.gov/coronavirus)

Sewn Cloth Face Covering

Materials

- Two 10"x6" rectangles of cotton fabric
- Two 6" pieces of elastic (or rubber bands, string, cloth strips, or hair ties)
- Needle and thread (or bobby pin)
- Scissors
- Sewing machine

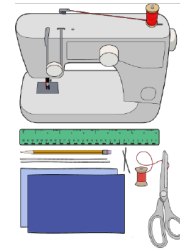

Tutorial

1. Cut out two 10-by-6-inch rectangles of cotton fabric. Use tightly woven cotton, such as quilting fabric or cotton sheets. T-shirt fabric will work in a pinch. Stack the two rectangles; you will sew the cloth face covering as if it was a single piece of fabric.

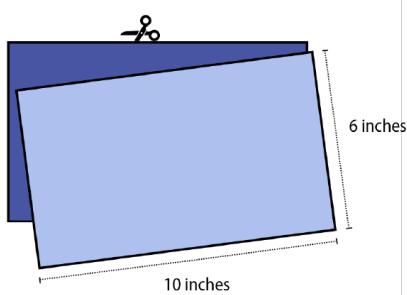

2. Fold over the long sides 1/4 inch and hem. Then fold the double layer of fabric over 1/2 inch along the short sides and stitch down.

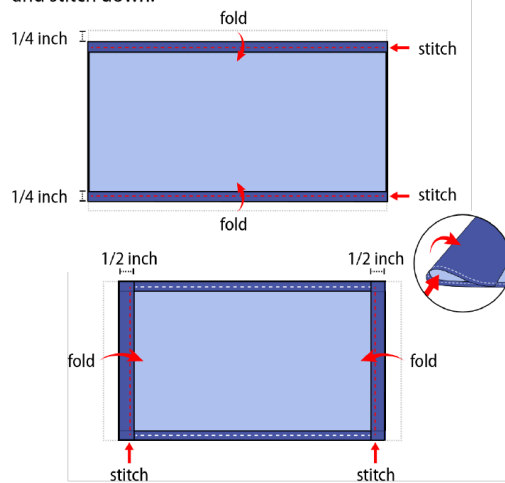

3. Run a 6-inch length of 1/8-inch wide elastic through the wider hem on each side of the cloth face covering. These will be the ear loops. Use a large needle or a bobby pin to thread it through. Tie the ends tight. Don't have elastic? Use hair ties or elastic head bands. If you only have string, you can make the ties longer and tie the cloth face covering behind your head.

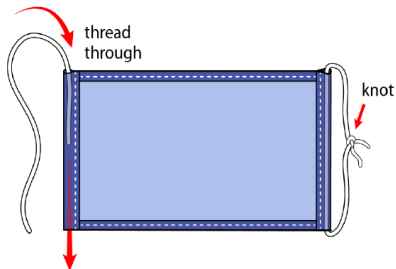

4. Gently pull on the elastic so that the knots are tucked inside the hem. Gather the sides of the cloth face covering on the elastic and adjust so the cloth face covering fits your face. Then securely stitch the elastic in place to keep it from slipping.

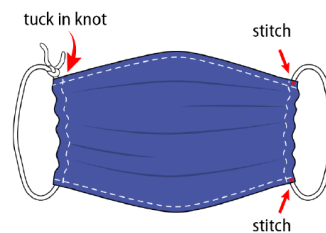

Quick Cut T-shirt Cloth Face Covering (no sew method)

Materials

- T-shirt
- Scissors

Tutorial

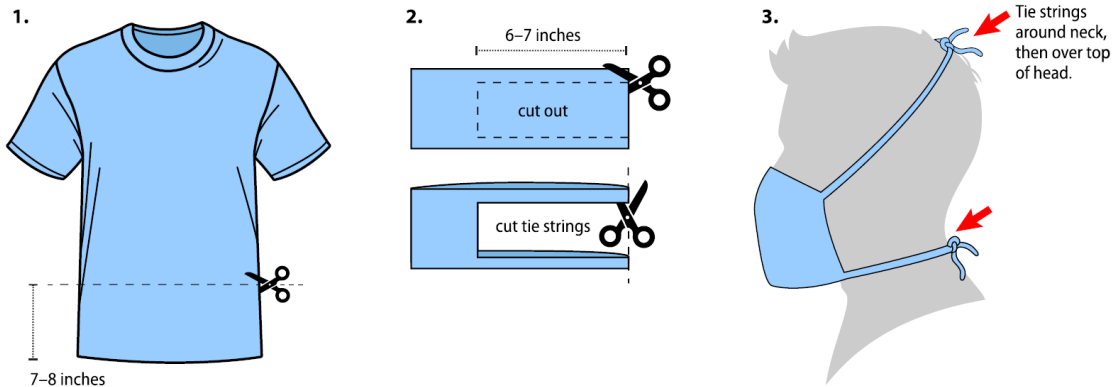

Bandana Cloth Face Covering (no sew method)

Materials

- Bandana (or square cotton cloth approximately 20"x20")
- Coffee filter
- Rubber bands (or hair ties)
- Scissors (if you are cutting your own cloth)

Tutorial

