

S&C Series 2000 Circuit-Switchers Outdoor Transmission

Remote Gas-Density Monitor
69 kV through 230 kV

Instructions for Installation

TABLE OF CONTENTS

Section	Page	Section	Page
INTRODUCTION		PROGRAMMING	
Qualified Persons	2	Programming the Receiver	12
Read this Instruction Sheet	2	UNDERSTANDING SYSTEM OUTPUTS	
Retain this Instruction Sheet	2	Normal Operating Conditions	15
Proper Application	2	System Alarms	15
Warranty	3	BATTERY REPLACEMENT	17
FCC Acceptance	3	TROUBLESHOOTING	
SAFETY INFORMATION		System Trouble Alarm Will Not Clear	19
Understanding Safety-Alert Messages	4	“Error” Message in Percent-Full Display	19
Following Safety Instructions	4	“Bad Checksum” Message Temporarily Displayed in System Status Display	20
Replacement Instructions and Labels	4	“Not Enough Data” Message Temporarily Displayed in System Status Display	20
INSPECTION AND PACKING	5	SPECIFICATIONS	
INSTALLATION		Spare Interrupters	21
Before Starting	6	Spare or Replacement Parts for Remote Gas-Density Monitor Option	21
Installing the Transmitter	6		
Installing the Receiver Antenna	9		
MONITORING SYSTEM START-UP	11		



S&C ELECTRIC COMPANY
Specialists in High-Voltage Switching and Protection

Instruction Sheet 716-530
February 7, 2005 ©2005
Supersedes Instruction Sheet 716-530 dated 2-11-02

INTRODUCTION



Qualified Persons

WARNING

The equipment covered by this publication must be installed, operated, and maintained by qualified persons who are knowledgeable in the installation, operation, and maintenance of electric power distribution equipment along with the associated hazards. A qualified person is one who is trained and competent in:

- The skills and techniques necessary to distinguish exposed live parts from non-live parts of electrical equipment.
- The skills and techniques necessary to determine the proper approach distances corresponding to the voltages to which the qualified person will be exposed.
- The proper use of the special precautionary techniques, personal protective equipment, insulating and shielding materials, and insulated tools for working on or near exposed energized parts of electrical equipment.

These instructions are intended only for such qualified persons. They are *not* intended to be a substitute for adequate training and experience in safety procedures for this type of equipment.

Read this Instruction Sheet

Read this instruction sheet thoroughly and carefully before installing or operating your S&C Remote Gas-Density Monitor. Familiarize yourself with “SAFETY INFORMATION” on page 3.

Retain this Instruction Sheet

This instruction sheet is a permanent part of your S&C Remote Gas-Density Monitor. These instructions should be stored in the operator cabinet of the Circuit-Switcher, using the instruction manual holder.

Proper Application

CAUTION

The equipment in this publication is only intended for use with an S&C Series 2000 Circuit-Switcher.



Warranty

The warranty and/or obligations described in S&C's standard conditions of sale, as set forth in Price Sheet 150, plus any special warranty provisions, as set forth in the applicable product-line specification bulletin, are exclusive. The remedies provided in the former for breach of these warranties shall constitute immediate purchaser's or end user's exclusive remedy and a fulfillment of all seller's liability. In no event shall seller's liability to immediate purchaser or end user exceed the price of the specific product which gives rise to immediate purchaser's or end user's claim. All other warranties whether express or implied or arising by operation of law, course of dealing, usage of trade or otherwise, are excluded. The only warranties are those stated in Price Sheet 150, and THERE ARE NO EXPRESS OR IMPLIED WARRANTIES OF MERCHANTABILITY OR FITNESS FOR A PARTICULAR PURPOSE. ANY EXPRESS WARRANTY OR OTHER OBLIGATION PROVIDED IN PRICE SHEET 150 IS GRANTED ONLY TO THE IMMEDIATE PURCHASER AND END USER, AS DEFINED THEREIN. OTHER THAN AN END USER, NO REMOTE PURCHASER MAY RELY ON ANY AFFIRMATION OF FACT OR PROMISE THAT RELATES TO THE GOODS DESCRIBED HEREIN, ANY DESCRIPTION THAT RELATES TO THE GOODS, OR ANY REMEDIAL PROMISE INCLUDED IN PRICE SHEET 150.

The seller's warranties are contingent upon the installation and adjustment of Series 2000 Circuit-Switcher in accordance with S&C's applicable instruction sheets, data sheets, and/or data bulletins.

FCC Acceptance

The transmitters used in the Series 2000 Circuit-Switchers Remote Gas-Density Monitor operate at a frequency of 916.5 MHz and are designed specifically for unlicensed remote-control and data-link applications that operate in the U.S.A. under FCC Part 15.249 and in Canada under TRS RSS-210. **No licenses are required.**

SAFETY INFORMATION



Understanding Safety-Alert Messages

There are several types of safety-alert messages which may appear throughout this instruction sheet as well as on labels attached to the Series 2000 Circuit-Switcher and remote gas-density monitor. Familiarize yourself with these types of messages and the importance of the various signal words, as explained below.

DANGER

“DANGER” identifies the most serious and immediate hazards which *will likely* result in serious personal injury or death if instructions, including recommended precautions, are not followed.

WARNING

“WARNING” identifies hazards or unsafe practices which *can* result in serious personal injury or death if instructions, including recommended precautions, are not followed.

CAUTION

“CAUTION” identifies hazards or unsafe practices which *can* result in minor personal injury or product or property damage if instructions, including recommended precautions, are not followed.

NOTICE

“NOTICE” identifies important procedures or requirements that *can* result in product or property damage if instructions are not followed.

Following Safety Instructions

If you do not understand any portion of this instruction sheet and need assistance, contact your nearest S&C Sales Office or S&C Authorized Distributor. Their telephone numbers are listed on S&C’s website www.sandc.com. Or call S&C Headquarters at (773) 338-1000; in Canada, call S&C Electric Canada Ltd. at (416) 249-9171.

NOTICE

Read this instruction sheet thoroughly and carefully before installing or operating your S&C Remote Gas-Density Monitor.



Replacement Instructions and Labels

If you need additional copies of this instruction sheet, contact your nearest S&C Sales Office, S&C Authorized Distributor, S&C Headquarters, or S&C Electric Canada Ltd.

It is important that any missing, damaged, or faded labels on the equipment be replaced immediately. Replacement labels are available by contacting your nearest S&C Sales Office, S&C Authorized Distributor, S&C Headquarters, or S&C Electric Canada Ltd.



Inspection

Examine the shipment for external evidence of damage as soon after receipt as possible, preferably before removal from the carrier's conveyance. Check the bill of lading to make sure that all shipping skids, crates, and containers listed thereon are present.

If there is visible loss and/or damage:

1. Notify the delivering carrier immediately.
2. Ask for a carrier inspection.
3. Note condition of shipment on all copies of the delivery receipt.
4. File a claim with the carrier.

If concealed damaged is discovered:

1. Notify the delivering carrier within 15 days of receipt of shipment.
2. Ask for a carrier inspection.
3. File a claim with the carrier.

Also notify S&C Electric Company in all instances of loss and/or damage.

Packing

The remote gas-density monitor consists of three transmitters, a receiver, a receiver antenna, mounting hardware, and a magnet tool.

The transmitters are shipped with the interrupters—one per interrupter. It is important to keep each transmitter with its associated interrupter, since it has been factory-calibrated for that specific interrupter. The interrupter and transmitter serial numbers should match exactly.

The receiver is factory-mounted in the operator—no assembly is required. The antenna bracket and its hardware are plastic-wrapped and can be found attached to the protective packaging of an insulating support column. Set these items aside in a protected area. A magnet tool for use with a standard hotstick is also included, and located on the inside of the operator enclosure door.

Unpack the remaining parts of the Circuit-Switcher as specified in its installation instructions.

NOTICE

Each transmitter is factory-calibrated for the interrupter with which it is shipped, and must be installed on its associated interrupter. The interrupter and transmitter serial numbers should match exactly. **Failure to do so can cause inaccurate and inconsistent gas-density readings.**

INSTALLATION



Before Starting

Before installing the transmitter, make sure to read, understand, and follow the instructions for installing the Series 2000 Circuit-Switcher. The remote gas-density monitor installation instructions are supplemental to the installation instructions for the Series 2000 Circuit-Switcher.

Installing the Transmitter

⚠ DANGER

Make sure that the Circuit-Switcher is de-energized, isolated from all power sources, and grounded at all six terminals before starting. **Working on an energized Circuit-Switcher can result in severe personal injury or death.**

Step 1

Before mounting an interrupter to its associated transition box, locate the red sensor cable on the base of the interrupter. Cut and remove the wire ties and the wire tie mounts securing the sensor cable, taking care not to damage the cable. Do not remove the shorting plug from the end of the green 6-pin connector at this time. See Figure 1.

⚠ CAUTION

Exercise care when mounting the interrupter to the transition box. The sensor cable is factory-installed on the interrupter and cannot be replaced in the field if damaged. **Damage to the cable will necessitate returning the interrupter and transmitter to the factory for replacement and recalibration.**

Step 2

On Circuit-Switchers with vertical interrupters (Model 2020 and Model 2030): The transmitter is mounted in place of the transition box access cover. Remove the four $\frac{5}{16}$ "-18 \times $\frac{3}{4}$ " socket-head cap screws that secure the transmitter to the transition box. Save the mounting hardware and set the transmitter aside in a protected area. See Figure 2a.

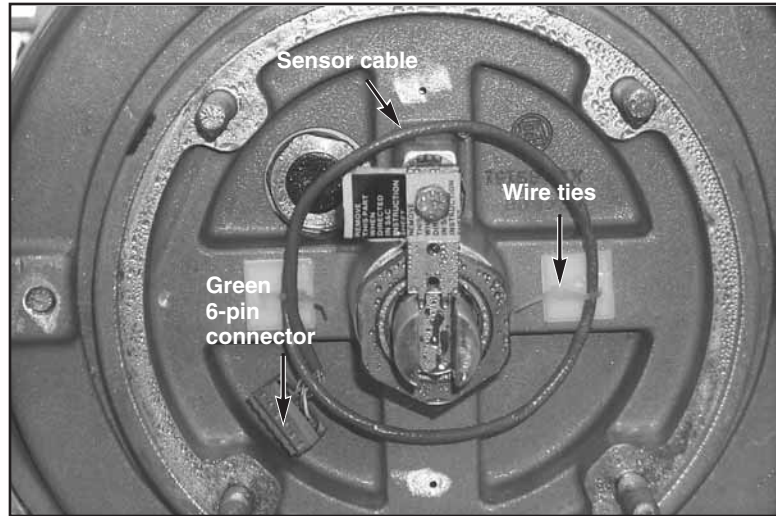

Figure 1. Remove wire ties and wire tie mounts from the sensor cable.

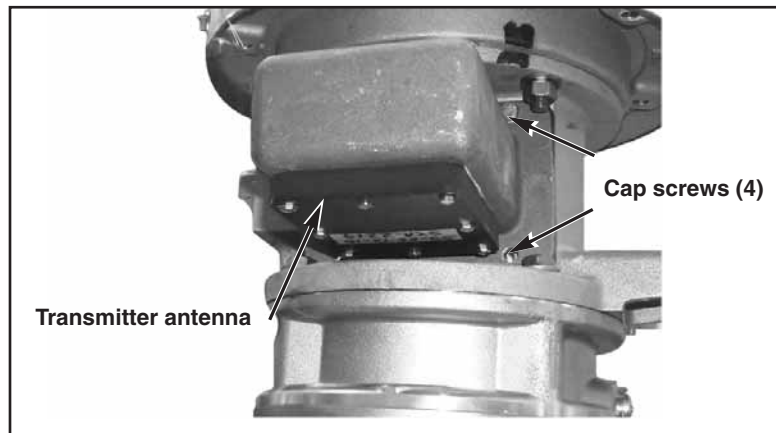

Figure 2a. Transmitter mounted on transition box with antenna facing the ground. (Model 2030 shown. Model 2020 similar.)



On Circuit-Switchers with horizontal interrupters (Model 2010 and Model 2040): The transmitter is mounted on an adapter panel. The adapter panel assembly is mounted in place of the transition box access cover. Remove the six stainless-steel $\frac{5}{16}$ "-18 \times $\frac{3}{4}$ " hex-head cap screws, with stainless-steel $\frac{5}{16}$ " flat washers that secure the adapter panel to the transition box. It is not necessary to separate the transmitter from the adapter panel. Save the mounting hardware and set the transmitter aside in a protected area. See Figure 2b.

NOTICE

Each transmitter is factory-calibrated for the interrupter with which it is shipped, and must be installed on its associated interrupter. The interrupter and transmitter serial numbers should match exactly. **Failure to do so can cause the remote gas-density monitoring system to deliver inaccurate readings.**

Step 3

On Circuit-Switchers with vertical interrupters (Model 2020 and Model 2030): During interrupter installation, feed the sensor cable in through the top of the transition box. Make sure the cable is fed through the transition box on the side of the operating rod that is towards the access opening. Feeding the sensor cable from behind the operating rod may cause the cable to catch on the rod during switch operation. See Figure 3a.

On Circuit-Switchers with horizontal interrupters (Model 2010 and Model 2040): During interrupter installation, feed the sensor cable in through the side of the transition box. Make sure the cable is not wound around the transition lever. Winding the cable from behind the transition lever may cause the cable to become disconnected. See Figure 3b.

CAUTION

Make sure the sensor cable is not caught on or wrapped around the Circuit-Switcher operating rod or transition lever. **Failure to do so can cause disconnection of the sensor cable, or damage to the cable that would necessitate replacing the interrupter.**

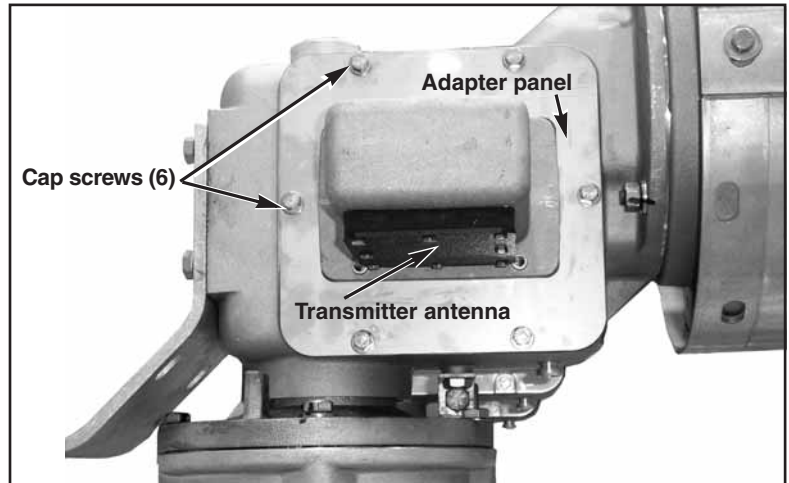

Figure 2b. Transmitter mounted to adapter panel. (Model 2040 shown. Model 2010 similar.)

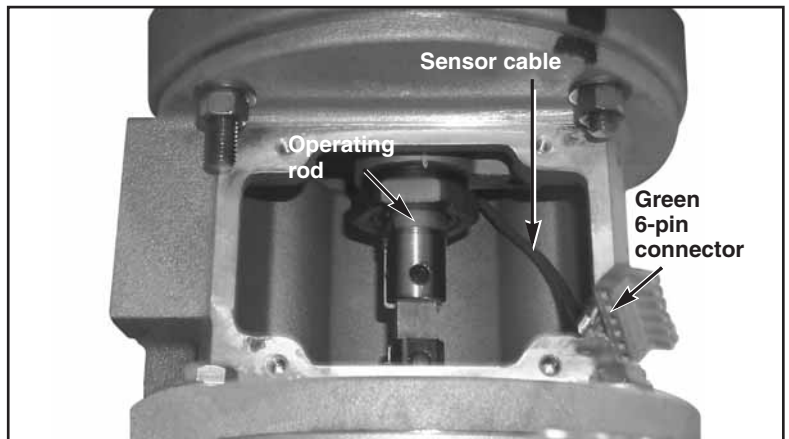

Figure 3a. Inside of transition box, showing sensor cable. Feed the cable through the transition box towards the front, to avoid snagging on the operating rod. (Model 2030 shown. Model 2020 similar.)

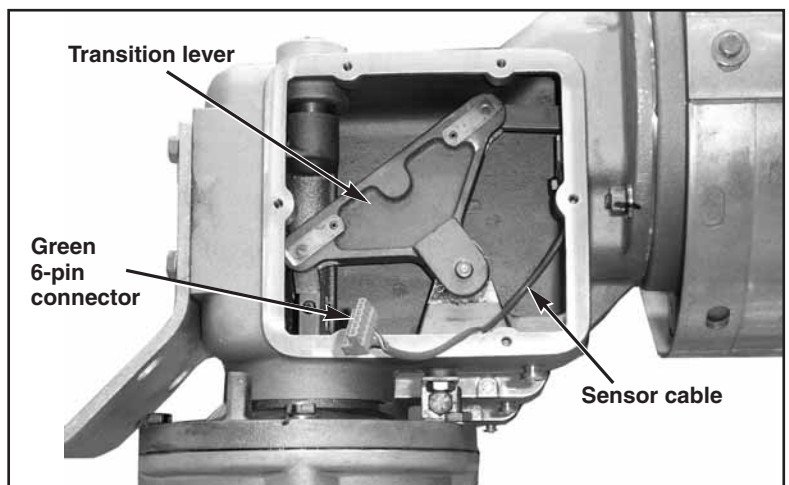

Figure 3b. Inside of transition box, showing sensor cable. Feed the cable through the transition box towards the front, to avoid snagging on transition lever. (Model 2040 shown. Model 2010 similar.)

INSTALLATION



Step 4

Attach the interrupter to the insulating column and couple it to the operating rod, as directed in the applicable Circuit-Switcher instruction sheet.

Step 5

Ground the transmitter to the transition box with the supplied grounding strap. Clamp one end of the grounding strap to the bottom of the transmitter housing, and the other to the transition box. See Figure 4.

⚠ CAUTION

Make sure the transmitter is fully grounded before connecting the battery or sensor cables. **Static and/or electrical discharge from the interrupter can damage the transmitter circuit board and sensor cable.**

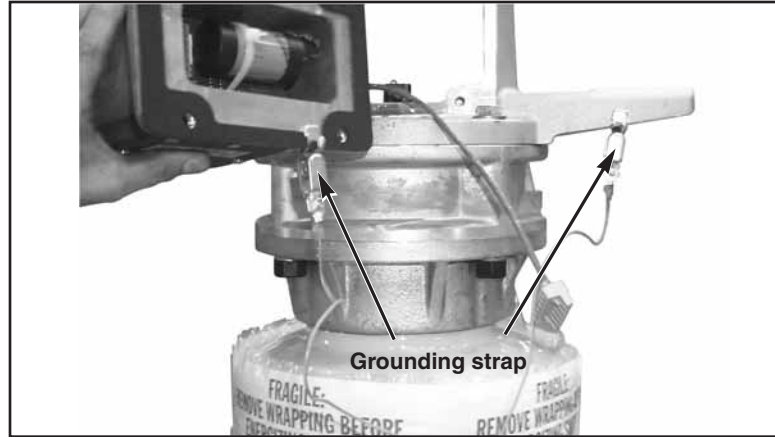

Figure 4. Attach one end of the grounding strap to the transmitter housing, and the other end to the transition box.

Step 6

Firmly plug the black, 2-pin battery connector into the black 2-pin socket on the transmitter circuit board. When properly installed, the locking tab on the connector will face away from the battery. See Figure 5.

Step 7

With the transmitter and transition box grounded, remove the shorting plug from the green 6-pin connector on the end of the red sensor cable. Remove the shorting plug from the 6-pin socket on the transmitter circuit board. Firmly plug the green 6-pin connector from the interrupter into the green 6-pin socket on the transmitter circuit board. See Figure 5. Discard the shorting plugs.

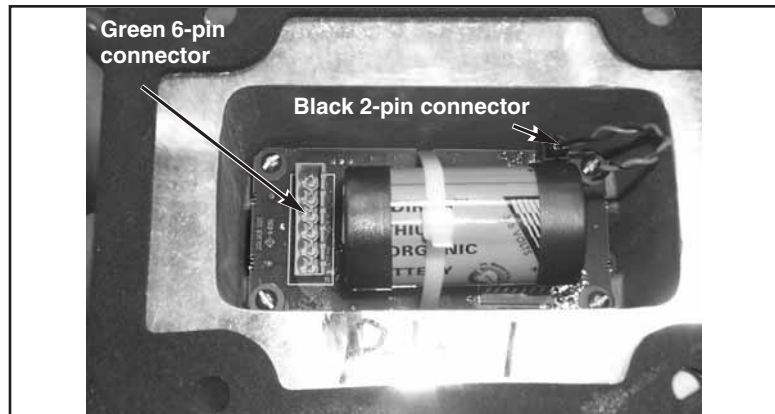

Figure 5. Plug the black 2-pin connector from the battery into the black 2-pin socket on the transmitter circuit board. Plug the green 6-pin connector from the interrupter into the green 6-pin socket on the circuit board.

⚠ CAUTION

Make sure the sensor cable is not caught on or wrapped around the Circuit-Switcher operating rod or transition lever. **Failure to do so can cause disconnection of the sensor cable, or damage to the cable that would necessitate replacing the interrupter.**

Step 8

Using the mounting hardware saved from Step 2, reattach the transmitter to the transition box, making sure that the black antenna cover faces the ground. See Figure 6.

Repeat Steps 1 through 8 for each interrupter. Retain the grounding strap for future use, in the pocket on the operator enclosure door.



Figure 6. Reattach the transmitter to the transition box after making the battery and sensor cable connections.



Installing the Receiver Antenna

Step 9

Mount the antenna bracket on the underside of the high-speed base in accordance with the Circuit-Switcher catalog drawing. When properly mounted, the bracket is perpendicular to the high-speed base, with the receiver antenna positioned as shown in Figure 7.

NOTICE

For Circuit-Switchers with vertical interrupters: If the transition boxes have been rotated 180° to attach the high-voltage conductors to the other side of the Circuit-Switcher, move the antenna bracket to the end of the base opposite that shown in the erection drawing. **Failure to do so can cause the remote gas-density monitoring system to malfunction.**

Step 10

Install the antenna cable along the underside of the high-speed base towards the operator tube support using the following procedure:

Remove up to four of the $\frac{1}{2}$ -13 \times $1\frac{1}{4}$ cap screws, flat washers, and nuts which secure the base covers to the high-speed base. Select locations evenly spaced along the base.

Install a tabbed washer between the nut and the base as shown in Figure 8. Replace and retighten the hardware.

NOTICE

The distance between the tabbed washers and the exact number of tabbed washers used will depend on the Series 2000 Circuit-Switcher model, mounting height, and the phase spacing. Four tabbed washers are provided in each antenna kit. Space the tabbed washers as evenly as possible along the underside of the high-speed base. On some models fewer than four tabbed washers or *no tabbed washers* may be required. **Refer to the supplied catalog drawing for details on the configuration of your Circuit-Switcher.**

Secure the antenna cable to the tabbed washers using the supplied cable ties. See Figure 8. Trim the cable ties if necessary.

Use the remaining cable ties supplied to secure the antenna cable along the operator tube support, leaving a minimum 9-inch (229-mm) radius “drip loop” in the cable at its entrance to the operator. Do not coil the excess cable.

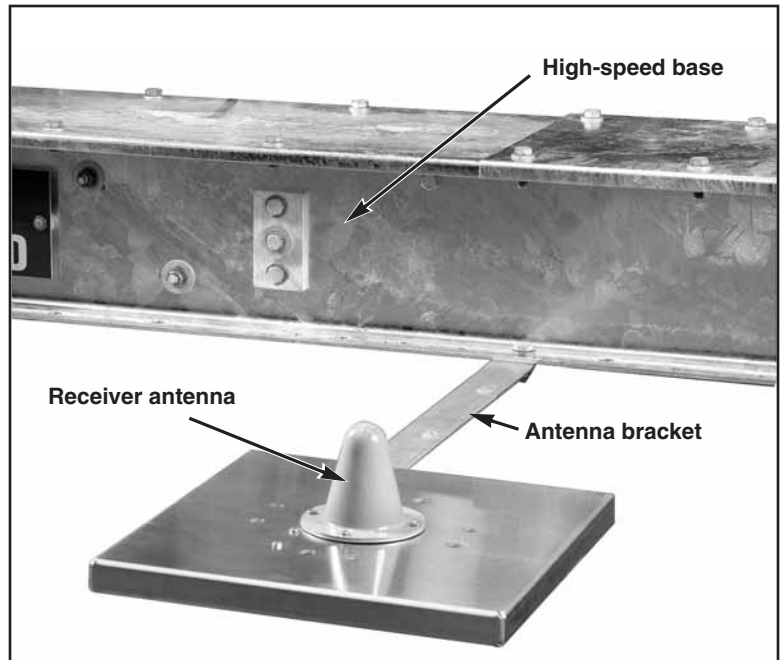

Figure 7. Mounting the antenna bracket.

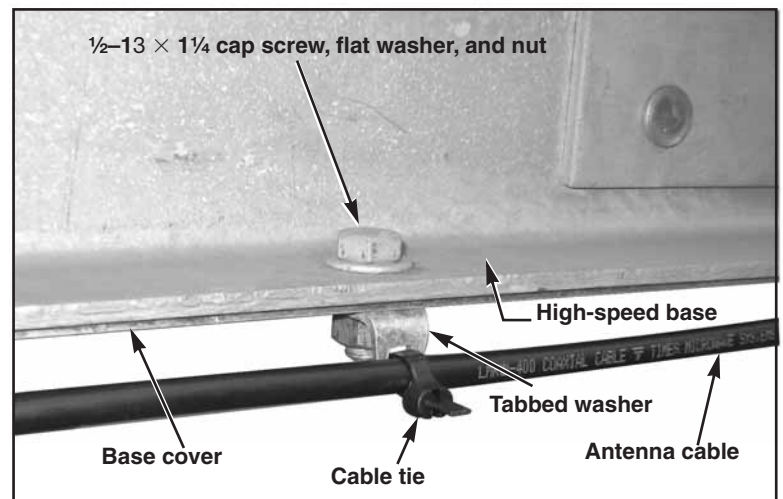

Figure 8. Secure the antenna cable underneath the high-speed base using the supplied tab washers and cable ties.

INSTALLATION



Step 11

Mark the location for the antenna cable on the conduit entrance plate in the bottom of the operator enclosure. Then remove the plate and drill a 3/4-inch hole at the marked location. Insert the supplied rubber grommet into the hole. Apply Dow Corning® 732 Multi-Purpose sealant or an equivalent water resistant sealing compound and replace the plate.

Step 12

Insert the antenna cable through the grommet hole in the conduit entrance plate. Screw the male end of the antenna cable to the female connection on the right side of the receiver. See Figure 9.

⚠ CAUTION

Do not apply control power until the Circuit-Switcher has been fully installed in accordance with the S&C instruction sheet furnished. **Failure to do so will cause damage to the operator mechanism.**

Step 13

Connect the alarm and analog input cables to the appropriate termination blocks below the receiver unit, per the supplied wiring diagram. Apply control power to the operator. Refer to the Circuit-Switcher operating instructions for details.

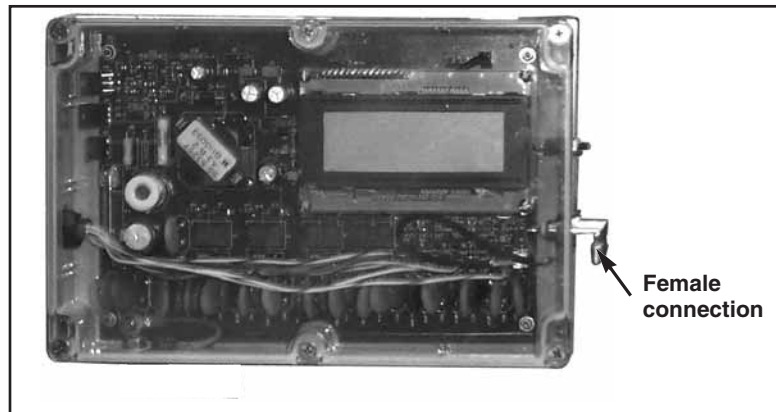

Figure 9. Receiver mounted inside operator.



MONITORING SYSTEM START-UP

The receiver unit is factory-set to display the data signal from Pole-Unit 1 as “A-phase,” the signal from Pole-Unit 2 as “B-phase,” and the signal from Pole-Unit 3 as “C-phase.” This information is shown on the liquid crystal display (LCD) and is available from the system analog outputs. See Figure10.

Step 14

Test the system by attaching the magnet tool to a hotstick long enough to reach the transmitter. The magnet tool can be found inside the door of the operator cabinet. Hold the magnet tool flush against the side of the transmitter with the serial number stamped on it for 10 seconds. Make sure that the two poles of the magnet are aligned vertically. See Figure 11. Gas-density data will be transmitted to the receiver immediately and shown on the LCD. Repeat for each transmitter.

NOTICE

Refer to the troubleshooting section starting on page 18 if the “NOT ENOUGH DATA” message appears in the display while using the magnet tool.

NOTICE

Gas-density data is transmitted once per hour. After initial start-up (and reboot), the system will wait one hour to collect and transmit gas-density data. When the magnet tool is applied to the transmitter, the transmitter is prompted to send a signal once every second. The transmitter will continue to send a signal for up to 10 seconds after the magnet tool is removed.

Step 15

Check the pole-unit designations on the LCD, and verify that the gas-density readings for all three phases are at 100%. If so, installation is complete. If the pole-unit designations are not correct, reprogramming of the receiver is required. Proceed to Step 16.

A [DENS]	100%	
B [DENS]	100%	
C [DENS]	100%	
A: OK	B: OK	C: OK

Figure10. Receiver LCD under normal operating conditions.

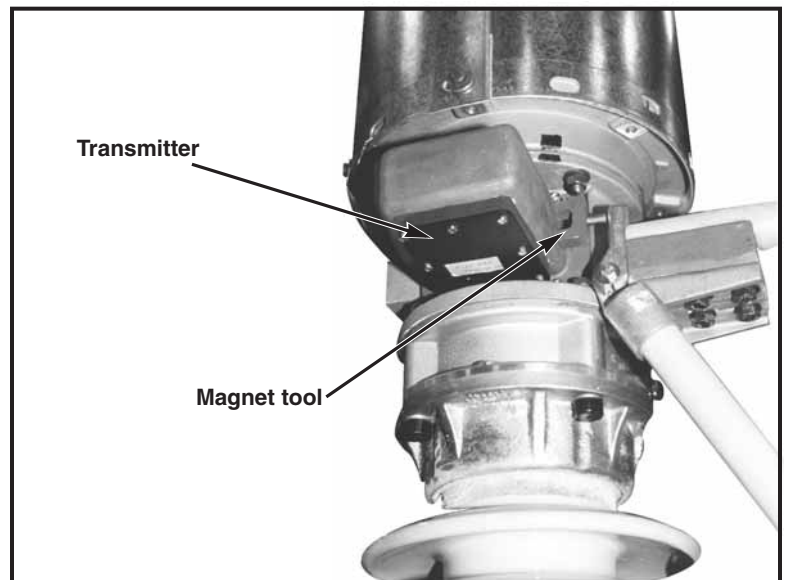

Figure 11. Close-up of magnet tool and transmitter, showing how to position tool.

Programming the Receiver

To reassign the pole-unit designations, the receiver must be reprogrammed. Programming “teaches” the receiver which transmitter radio signal corresponds to which interrupter.

A series of prompts on the LCD will guide you through the programming process.

Step 16

Attach the supplied magnet tool to a hotstick long enough to reach the transmitter.

Step 17

Press—and hold for 10 seconds—the system set-up button located on the right side of the receiver. See Figure 12. The receiver will start to count down. See Figure 13. Release the set-up button when prompted. See Figure 14. This will put the receiver in set-up mode.

NOTICE

Inadvertently releasing the button during countdown will stop set-up and reset the receiver.

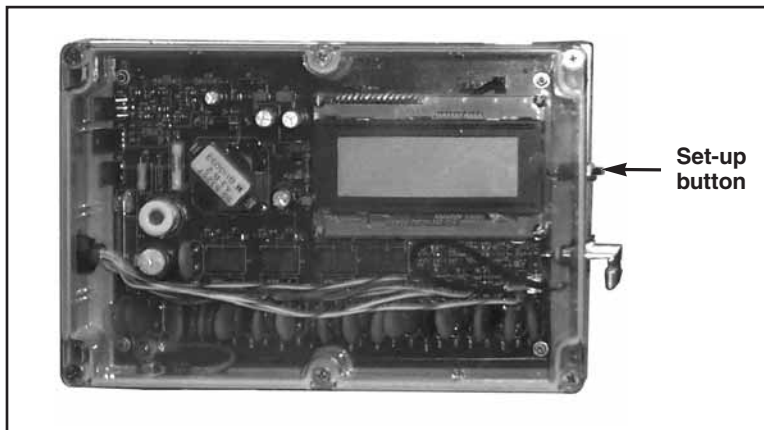

Figure 12. Location of set-up button on receiver.

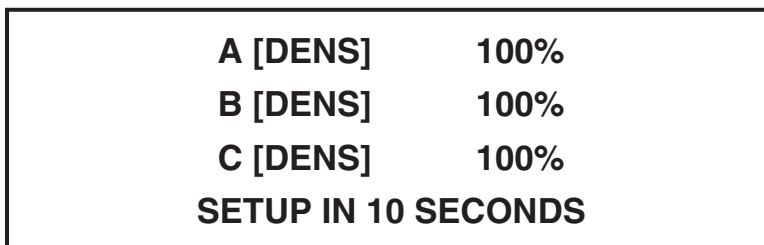

Figure 13. Receiver LCD while pressing and holding set-up button.



Figure 14. Receiver LCD during start of set-up mode.



Step 18

Press and hold—for 5 seconds—the set-up button. The A-phase set-up prompt will display. See Figure 15.

Step 19

To initialize A-phase, press and release the set-up button again. Then position and hold the magnet tool flush against the side of the transmitter that has the serial number stamped onto it. See Figure 11. Make sure that the two poles of the magnet are aligned vertically. When the receiver starts counting signals from the transmitter, remove the magnet tool. See Figure 16.

When the magnet tool is applied correctly, the receiver will display the serial number of the interrupter/transmitter. After 10 rapid signals are detected, the display will prompt you to move on to B-phase, and then C-phase. See Figures 16 and 17.

NOTICE

During normal operation, the transmitter sends a signal once per hour. When the magnet tool is applied to a transmitter, the transmitter is prompted to send a signal once every second. The transmitter will continue to send a signal for up to 10 seconds after the magnet tool is removed.

The system will assign phase designations in the order in which the phases are initialized. The first phase initialized will be assigned the letter “A,” the second “B,” and the third “C.” Make sure that the phases are initialized in the order appropriate for the installation.

Store the magnet tool inside the door of the switch operator cabinet for future use.

Repeat Step 19 for B-phase and then again for C-phase.

**S&C RGDM A-Phase Set
Up. Use Magnet To Start
A-Phase Remote.
Press Button To Go**

Figure 15. Receiver LCD prompt for magnet tool.

**S&C RGDM “A” Phase
SS-0608-001 : 9**

Figure 16. Receiver LCD counting transmissions from transmitter.

**Got 10 Packets From
SS-0608-001
Which Is Phase “A”**

Figure 17. Receiver LCD after receiving 10 signals from transmitter.



Step 20

After all three phases are initialized, the LCD will show the three interrupter serial numbers in the order the phases were initialized. The display will sequentially alternate the messages shown in Figures 18a, 18b, and 18c. Hold down the set-up button for 5 seconds. This will clear the previous settings from the receiver and save the new settings. When the update has been completed, the LCD will display a “Release Button” prompt. Release the set-up button. The receiver will reboot.

NOTICE

If the pole-units are not in the correct sequence, wait for the receiver to time out and reboot (approximately 2 minutes). Disconnecting power to the operator during set-up will also reboot the system.

After programming has been completed, the display *will not* indicate which interrupter serial number is associated with each phase again. Please make a note of which interrupter serial number is associated with each phase for future reference.

Step 21

Test the system by attaching the magnet tool to a hotstick long enough to reach the transmitter. Hold the magnet tool flush against the side of the transmitter with the serial number stamped on it. See Figure 11. Repeat for each transmitter. Gas-density data will be transmitted to the receiver and shown on the LCD.

Step 22

Check the pole-unit designations on the LCD, and verify that the gas-density readings for all three phases are at 100%. If so, installation is complete. If the pole-unit designations are not correct, reprogramming of the receiver is required. Proceed to Step 16.

Check Serial Numbers

SS-0608-001

SS-0608-002

SS-0608-003

Figure 18a. Receiver LCD after all three phases are initialized.

If Serial Numbers
Are Correct Press &
Hold To Save Them

Figure 18b. Receiver LCD after all three phases are initialized

If Serial Numbers
Are Wrong, Wait For
Receiver To Reset
And Do Setup Again.

Figure 18c. Receiver LCD after all three phases are initialized.



UNDERSTANDING SYSTEM OUTPUTS

Normal Operating Conditions

The remote gas-density monitor provides local and remote indication of the gas-density in each interrupter in terms of percent-full. The system can be wired to provide remote indication of the gas density of each interrupter via three analog 0 to 1.0-mA dc outputs. The LCD provides indication of gas-density and alarms for each interrupter. See Figure 19.

The remote gas-density monitor transmits updated measurements approximately once per hour. If gas-density data is desired immediately, attach the supplied magnet tool to a hot-stick long enough to reach the transmitter. Hold the magnet tool flush against the side of the transmitter as shown in Figure 11 on page 10. Repeat for each phase. Gas-density data will be transmitted to the receiver and shown on the LCD, and sent to the outputs.

System Alarms

The remote gas-density monitor has three available alarm contacts. The system provides both local and remote indication of alarms.

Level 1 Alarm: A Level 1 alarm indicates that an interrupter is leaking. The Circuit-Switcher can still be operated, but the leaking interrupter should be replaced promptly. The LCD will appear as shown in Figure 20.

NOTICE

Since the SF₆ gas in the interrupter will begin to condense at low temperatures, the Level 1 alarm is disabled when the temperature reaches below -20°F (-29°C) so as not to provide a false alarm.

Level 2 Alarm: A Level 2 alarm indicates that an interrupter has lost enough SF₆ gas that it can no longer clear faults properly.

A [DENS]	100%	
B [DENS]	100%	
C [DENS]	100%	
A: OK	B: OK	C: OK

Figure 19. Receiver LCD under normal operating conditions.

A [DENS]	90%	
B [DENS]	100%	
C [DENS]	100%	
A: LVL1	B: OK	C: OK

Figure 20. Example of receiver LCD under Level 1 alarm state.

UNDERSTANDING SYSTEM OUTPUTS



⚠ CAUTION

Do not operate the Circuit-Switcher when the remote gas-density monitor display indicates a Level 2 alarm. **Replace the interrupter before operating the Circuit-Switcher.** The Circuit-Switcher may not interrupt properly under a Level 2 alarm state.

Replace the interrupter promptly. DO NOT operate a Circuit-Switcher with a Level 2 alarm. The LCD will appear as shown in Figure 21.

As a point of information, the primary-fault interrupting ratings of Series 2000 Circuit-Switchers under normal operating conditions, Level 1 alarm state, and Level 2 alarm state are indicated in Table I.

System Trouble Alarm: The system trouble alarm indicates a problem with the monitoring system. A system trouble alarm will activate when the receiver fails to receive a signal for over 24 hours. The LCD will appear as shown in Figure 22.

The system trouble alarm will also activate when there are approximately three months or less of battery life remaining. At first, a “Low-Battery” alarm will appear locally. See Figure 23. After the battery has completely discharged, an “Error” message will display in place of the gas-density information, and the system trouble alarm will signal remotely.

Battery-Life: The transmitter batteries have a service life of 10 years. To ensure continuous operation, S&C recommends changing the battery at least once every 8 years. The system trouble alarm will activate when a battery has approximately three months of life remaining. See Figure 23.

A [DENS]	75%
B [DENS]	100%
C [DENS]	100%
A: LVL 2	B: OK C: OK

Figure 21. Example of receiver LCD under Level 2 alarm state.

Table I. Primary-Fault Interrupting Ratings

System Voltage Rating, kV	Primary-Fault Interrupting Ratings		
	Normal	Level 1	Level 2
69 115 138	25 kA	20 kA	Do not operate
161 230	20 kA	15 kA	Do not operate

A [DENS]	ERROR
B [DENS]	100%
C [DENS]	100%
A: SYS	B: OK C: OK

Figure 22. Example of receiver LCD under system trouble alarm state.

A [DENS]	100%
B [DENS]	100%
C [DENS]	100%
A: BATT	B: OK C: OK

Figure 23. Receiver LCD under system trouble alarm state.



BATTERY REPLACEMENT

DANGER

Make sure that the Circuit-Switcher is de-energized, isolated from all power sources, and grounded at all six terminals before starting. **Working on an energized Circuit-Switcher can result in severe personal injury or death.**

Step 23

Remove the hardware securing the transmitter to the transition box. See Figure 2 on page 5. Reserve the hardware. For details on hardware, refer to the transmitter mounting instructions in Step 2.

Step 24

Ground the transmitter unit to the transition box with the supplied grounding strap. See Figure 4. Clamp one end of the grounding strap to the bottom of the transmitter housing, and the other to the transition box. (Refer to Step 5 on page 7.) Unplug the green 6-pin connector from the transmitter circuit board. See Figure 24.

CAUTION



OBSERVE PRECAUTIONS FOR HANDLING ELECTROSTATIC SENSITIVE DEVICES

Wear a grounding strap when handling the circuit board or ground yourself by touching a grounded part of the Circuit-Switcher before handling. **Failure to do so may cause damage to electronic parts.**

Step 25

Remove the circuit board from the transmitter by removing the four #6-32 \times $\frac{1}{4}$ " round-head machine screws located at the four corners of the circuit board. See Figure 24. Handle the circuit board by its edges. Save the four screws.

Step 26

Unplug the black 2-pin battery connector from the circuit board and cut the wire tie. Remove the old battery and discard.

Step 27

To secure the new replacement battery, wrap the furnished wire tie around the circuit board, as shown in Figure 24. Trim the wire tie end. Firmly plug the black 2-pin connector from the battery into the black 2-pin socket on the circuit board. When properly attached, the locking tab will face away from the battery.

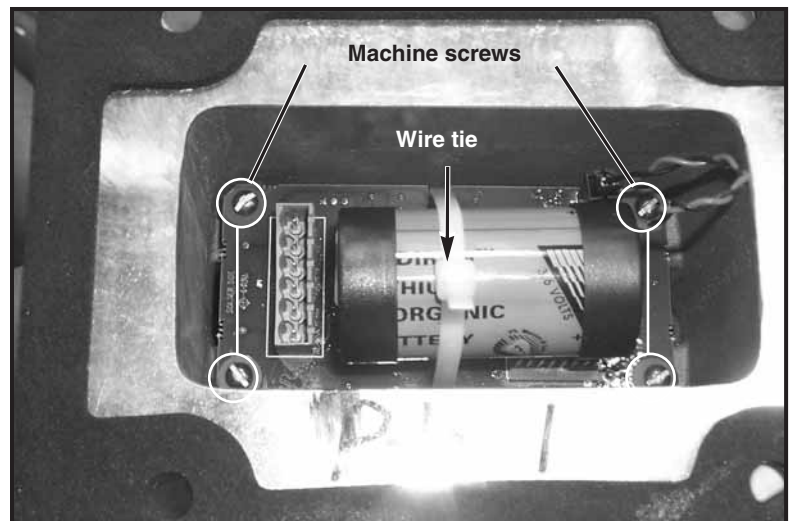

Figure 24. Removing transmitter circuit board. Disconnect the green 6-pin connector and the battery. Remove the circuit board and replace battery. Secure replacement battery with wire tie.

BATTERY REPLACEMENT



Step 28

Reattach the circuit board to the transmitter using the four mounting screws saved earlier. See Figure 5 on page 7. Firmly plug the green 6-pin connector from the interrupter, to the green 6-pin connector on the circuit board.

Step 29

Remove the grounding strap, and reattach the transmitter to the transition box so that the black antenna faces the ground. See Figure 25. Repeat Steps 23 through 29 for the remaining transmitters.

NOTICE

Make sure the sensor cable is not caught on the Circuit-Switcher operating rod or transition lever. **Failure to do so can cause the remote gas-density monitor system to malfunction.**

The unit is now ready for service. To test the transmitter, position and hold the magnet tool flush against the side of the transmitter that has the serial number stamped into it. See Figure 11 on page 10. The receiver will display updated information for that phase.

NOTICE

Replacing the battery will not necessitate re-initialization or rebooting of the system.



Figure 25. Reattach transmitter to transition box. Make sure that the black antenna panel is facing the ground.



System Trouble Alarm Will Not Clear

A system trouble alarm will be initiated under the following conditions:

- Receiver hasn't received a signal from a pole-unit for over 24 hours.
- Low battery voltage—three months or less of battery life remain.

Check the following:

1. Visually check the transmitters and receivers to see if there is anything that would obstruct the signal (i.e., a bird nest or debris). Clear any obstructions.
2. Check the coaxial cable connection from the receiver antenna to the receiver inside the operator to make sure it hasn't been disconnected.
3. Check the receiver antenna to make sure it is installed in accordance with the Circuit-Switcher's erection drawing. If the alarm is still present, try moving the antenna along the high-speed base until the transmitter signals are received. Remount the antenna.
4. Check all battery connections to make sure they are secure. If the batteries are nearing the end of their 10-year service life, replace them.
5. Inclement or severe weather conditions lasting for more than 24 hours may interfere with the transmitter signal. If the alarm does not clear after weather conditions stabilize, check for storm damage or excessive ice/snow accumulation on the antenna.

If the system trouble alarm still won't clear, contact the nearest S&C Sales Office.

"Error" Message in Percent-Full Display

An "error" message and system trouble alarm will appear on the display instead of the percent-full reading for the pole-units if the sensor cable has been damaged, or if the green 6-pin connector has been disconnected from the transmitter circuit board. See Figure 26.

Check the following:

1. Check the sensor cable inside the transition box to make sure it hasn't been damaged or caught on the Circuit-Switcher operating rod.
2. Check the transmitter circuit board and make sure the green 6-pin connector is properly in its socket.

If the error message still won't clear, contact the nearest S&C Sales Office.

NOTICE	
After attempting any of the above solutions to prompt the transmitter to send an immediate signal, position and hold the magnet tool flush against the side of the transmitter. See Figure 10 on page 10.	
Under normal operating conditions, the transmitter only sends a signal once per hour.	

A [DENS]	ERROR
B [DENS]	100%
C [DENS]	100%
A: SYS	B: OK C: OK

Figure 26. Receiver LCD "Error" message.



TROUBLESHOOTING

"Bad-Checksum" Message Temporarily Displayed in System Status Display

A "Bad Checksum" message appearing in the receiver display either before or after applying the magnet tool to the side of the transmitter housing is an indication of damage to the transmitter assembly. See Figure 27.

A [DENS]	100%
B [DENS]	100%
C [DENS]	100%
BAD CHECKSUM	

Figure 27. Receiver LCD "Bad Checksum" message.

An alarm status will usually display after the "Bad Checksum" message clears. If the "Bad Checksum" message or resulting system trouble alarm is initiated:

Check the following:

1. If the "SYS" alarm is present for the phase farthest away from the receiver antenna, remount the receiver antenna closer to that phase. Apply the magnet tool to the corresponding transmitter. The "Bad Checksum" and "SYS" alarms should clear.
2. If a "SYS" alarm is still present for the pole-unit tested in (1), contact the nearest S&C Sales Office.

"Not Enough Data" Message Temporarily Displayed in System Status Display

The magnet tool should be held against the transmitter for at least ten seconds when prompting the transmitter to signal. A "Not Enough Data" message may temporarily appear in the system status display if the magnet tool is held to the transmitter for less than ten seconds. See Figure 28.

A [DENS]	100%
B [DENS]	100%
C [DENS]	100%
NOT ENOUGH DATA	

Figure 28. Receiver LCD "No Enough Data" message.

If the "Not Enough Data" occurs when the magnet tool is not being applied to the transmitter, contact the nearest S&C Sales Office.



SPECIFICATIONS

SPARE INTERRUPTERS

Applicable to Circuit-Switcher Rating, kV	Interrupter ^① Catalog Number
69 through 138	SA-41695-A
69 through 138	SA-41695-1-A■
69 through 138	SXA-2218-A▲
69 through 138	SXA-2218-1-A▲■
161 and 230	SA-42900-A
161 and 230	SA-42900-1-A■
161 and 230	SXA-2219-A▲
161 and 230	SXA-2219-1-A▲■

① Interrupters exhibiting low gas-pressure indication (red target), and having porcelain housing in good condition may be exchanged for new interrupters. To ensure proper handling, refer to the nearest S&C Sales Office and obtain for the customer a special serially numbered label to place on the shipping container. Instruct the customer to enclose a packing slip showing purchase order or requisition number covering the exchange. The customer should ship the replaced interrupter, transportation charges prepaid, to S&C Electric Company, Repair Center, 1800 Devon Avenue, Chicago, Illinois 60660-1010.

▲ These interrupters are outfitted with sensing equipment for the remote gas-density monitor; each interrupter also includes a new transmitter. These interrupters are intended for Circuit-Switchers already equipped with a remote gas-density monitor, and do not include a complete monitoring system. If a complete remote gas-density monitor is desired, refer to the nearest S&C Sales Office.

■ Low-temperature interrupter intended for Circuit-Switchers with the “-N2” option.

SPARE OR REPLACEMENT PARTS FOR REMOTE GAS-DENSITY MONITOR OPTION

Part	Model	Rating, kV	Catalog Number
Transmitter Battery	All	All	9933-547
Magnet Tool. For use in testing/programming receiver	All	All	SXA-2231