

# INSTRUCTIONS

## For Field Replacement

### TABLE OF CONTENTS

Section	Page Number	Section	Page Number
<b>INTRODUCTION</b>		<b>BEFORE STARTING INTERRUPTER REPLACEMENT</b>	
Qualified Persons .....	1	REPLACEMENT .....	4
Read this Instruction Sheet .....	2	<b>INTERRUPTER REPLACEMENT</b>	
Retain this Instruction Sheet .....	2	ON MODELS 2020, 2025, AND 2030 .....	5
Proper Application .....	2	<b>INTERRUPTER REPLACEMENT</b>	
Warranty .....	2	ON MODELS 2010, 2015, and 2040 .....	12
<b>SAFETY INFORMATION</b>		<b>INTERRUPTERS WITH THE REMOTE GAS-DENSITY MONITOR OPTION</b>	
Understanding Safety-Alert Messages .....	3	Installing the Transmitter .....	18
Following Safety Instructions .....	3	Programming the Receiver .....	22
Replacement Instructions and Labels .....	3	<b>INSPECTION SCHEDULE AND PROCEDURES</b> .....	
<b>INSPECTION AND PACKING</b>			24
Inspection .....	4		
Packing .....	4		

### INTRODUCTION

The following instructions are for field replacement of interrupters for S&C Series 2000 Circuit-Switchers rated 69 kV through 230 kV.

The Series 2000 Circuit-Switcher interrupter is a porcelain-enclosed, hermetically sealed device containing sulfur-hexafluoride (SF<sub>6</sub>) gas under pressure. It employs an operating rod which is driven to the open position at high speed, by means of a power train connected to the Series 2000 Circuit-Switcher Operator, to effect circuit interruption. This operating rod is also driven to the closed position at high speed to effect circuit closing within the interrupter.

### Qualified Persons

#### **WARNING**

The equipment covered by this publication must be installed, operated, and maintained by qualified persons who are knowledgeable in the installation, operation, and maintenance of electric power distribution equipment along with the associated hazards. A qualified person is one who is trained and competent in:

- The skills and techniques necessary to distinguish exposed live parts from non-live parts of electrical equipment.
- The skills and techniques necessary to determine the proper approach distances corresponding to the voltages to which the qualified person will be exposed.
- The proper use of the special precautionary techniques, personal protective equipment, insulating and shielding materials, and insulated tools for working on or near exposed energized parts of electrical equipment.

These instructions are intended only for such qualified persons. They are *not* intended to be a substitute for adequate training and experience in safety procedures for this type of equipment.



**INTRODUCTION —Continued****Read this Instruction Sheet**

Read this instruction sheet thoroughly and carefully before installing or operating your S&C Series 2000 Circuit-Switcher. Familiarize yourself with “SAFETY INFORMATION” on page 3.

**Retain this Instruction Sheet**

This instruction sheet is a permanent part of your S&C Series 2000 Circuit-Switcher. These instructions should be stored in the operator cabinet of the circuit-switcher, using the instruction manual holder.

**Proper Application****⚠ CAUTION**

The replacement interrupter(s) and associated equipment in this publication is (are) only intended for use with an S&C Series 2000 Circuit-Switcher. Series 2000 replacement parts are not interchangeable with the interrupter(s) and equipment designed for other S&C Circuit-Switcher models.

**Warranty**

The standard warranty contained in S&C's standard conditions of sale, as set forth in Price Sheet 150, is applicable to the S&C Series 2000 Circuit-Switcher covered in this instruction sheet. Warranty of Series 2000 Circuit-Switcher is contingent upon the installation of Series 2000 Circuit-Switcher in accordance with S&C's applicable instruction sheets, data sheets, and/or data bulletins.



## SAFETY INFORMATION

### Understanding Safety-Alert Messages

There are several types of safety-alert messages which may appear throughout this instruction sheet as well as on labels attached to the Series 2000 Circuit-Switcher. Familiarize yourself with these types of messages and the importance of the various signal words, as explained below.

#### DANGER

“DANGER” identifies the most serious and immediate hazards which *will likely* result in serious personal injury or death if instructions, including recommended precautions, are not followed.

#### WARNING

“WARNING” identifies hazards or unsafe practices which *can* result in serious personal injury or death if instructions, including recommended precautions, are not followed.

#### CAUTION

“CAUTION” identifies hazards or unsafe practices which *can* result in minor personal injury or product or property damage if instructions, including recommended precautions, are not followed.

#### NOTICE

“NOTICE” identifies important procedures or requirements that *can* result in product or property damage if instructions are not followed.

### Following Safety Instructions

If you do not understand any portion of this instruction sheet and need assistance, contact your nearest S&C Sales Office or S&C Authorized Distributor, or call S&C Headquarters at (773) 338-1000, Monday through Friday between 8:30 AM and 5:00 PM Central Standard Time. (In Canada, call S&C Electric Canada Ltd. at (416) 249-9171, Monday through Friday between 8:00 AM and 5:00 PM Eastern Standard Time.)

#### NOTICE

Read this instruction sheet thoroughly and carefully before installing or operating your S&C Series 2000 Circuit-Switcher



### Replacement Instructions and Labels

If you need additional copies of this instruction sheet, contact your nearest S&C Sales Office, S&C Authorized Distributor, S&C Headquarters, or S&C Electric Canada Ltd.

It is important that any missing, damaged, or faded labels on the equipment be replaced immediately. Replacement labels are available by contacting your nearest S&C Sales Office, S&C Authorized Distributor, S&C Headquarters, or S&C Electric Canada Ltd.



**INSPECTION AND PACKING**

**Inspection**

Examine the shipment for external evidence of damage as soon after receipt as possible, preferably before removal from the carrier's conveyance. Check the bill of lading to make sure that all shipping skids, crates, and containers listed thereon are present.

If there is visible loss and/or damage:

1. Notify the delivering carrier immediately.
2. Ask for a carrier inspection.
3. Note condition of shipment on all copies of the delivery receipt.
4. File a claim with the carrier.

If concealed damaged is discovered:

1. Notify the delivering carrier within 15 days of receipt of shipment.
2. Ask for a carrier inspection.
3. File a claim with the carrier.

Also notify S&C Electric Company in all instances of loss and/or damage.

**Packing**

The Series 2000 Circuit-Switcher interrupter is a porcelain-enclosed, hermetically sealed device containing sulfur-hexafluoride (SF<sub>6</sub>) gas under pressure (75 PSI). To guard against breakage and possible hazard to personnel, the Series 2000 Circuit-Switcher interrupter is shipped in a bolted-on container. Replacement interrupters are shipped with this container in place. Do not remove the interrupter container until so directed in the following instructions. A separate interrupter container and associated hardware is shipped with the replacement interrupter for use during replacement.

**BEFORE STARTING INTERRUPTER REPLACEMENT**

 **DANGER**

Make sure that the Circuit-Switcher is de-energized, isolated from all power sources, and grounded at all six terminals before starting. **Working on an energized Circuit-Switcher can result in severe personal injury or death.**

*For Series 2000 Circuit-Switchers with **vertical** interrupters—Models 2020, 2025, and 2030—proceed to page 5. For Series 2000 Circuit-Switchers with **horizontal** interrupters—Models 2010, 2015, and 2040—proceed to page 12.*



## INTERRUPTER REPLACEMENT ON MODELS 2020, 2025, AND 2030

### Step 1

After following the user's standard procedures for clearing and tagging equipment on which work is to be performed, close the Circuit-Switcher by pressing the "CLOSE" push button on the operator.▲ Then remove the trip-circuit and control-circuit fuseholders or—on newer operators—open the control-source disconnect switch and remove the motor-and-closing circuit fuseholder from the operator. Push the manual trip lever counterclockwise to trip the interrupters. Do not replace the fuseholder(s) until so directed.

*Do not open the disconnect on Model 2020 Circuit-Switchers by means of the manual charging handle. The Series 2000 Circuit-Switcher Operator must remain discharged during the interrupter replacement procedure.*

### Step 2

Install the spare interrupter container, furnished with the replacement interrupter, around the interrupter to be replaced, using the following procedure:

- (a) Remove the two container-halves from the shipping crate. Note that one of the container-halves is fur-

nished with a loosely attached  $\frac{3}{8}$ "—16×2" carriage bolt at each end. Position this container-half so that the carriage-bolt threads protrude through the holes at the ends of the other container-half as shown in Figure 1.

- (b) Thread a  $\frac{3}{8}$ "—16 zinc-plated serrated hex nut on each of the two  $\frac{3}{8}$ "—16×2" carriage bolts. Tighten each hex nut just a few turns. See Figure 1.
- (c) Attach suitable lifting slings to the lifting rings at one end of the container-half assembly. See Figure 2. Raise the container into position around the interrupter.

▲ Trip-close push buttons are not included on operators specified with catalog number suffix "-J." In such instances, momentarily jumper terminals 1 and 3 to close the Circuit-Switcher.

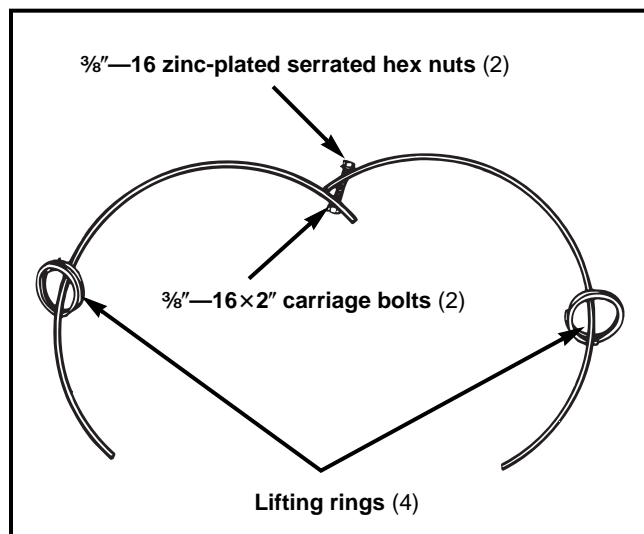

Figure 1. Assembling spare interrupter container.



Figure 2. Raising spare interrupter container into position on interrupter being replaced. Model 2030 Circuit-Switcher illustrated; Models 2020 and 2025 are similar.

**INTERRUPTER REPLACEMENT ON MODELS 2020, 2025, AND 2030 — Continued**

- (d) Using a screwdriver as necessary to spread the edges, snap the two halves together as shown in Figure 3. Place a  $\frac{3}{8}$ "—16 zinc-plated serrated hex nut on each of the captive  $\frac{3}{8}$ "—16 $\times$  $\frac{3}{4}$ " carriage bolts that run the length of the container-halves.
- (e) Attach the container-halves at the indicator end of the interrupter using one of the cables furnished. See Figure 3 (right). Thread the cable through adjacent holes in the container-halves, as shown. Position the cable around the indicator end casting, then thread the cable through adjacent holes in the container-halves, on the other side. **Do not attach clamps to the cable at this time.**
- (f) Attach the container-halves at the coupling end of the interrupter in a similar manner, using the other cable furnished. See Figure 3 (left). Slide the container-halves back or forth as necessary to allow the cable to be threaded through the holes.
- (g) Pull the cable taut at the indicator end of the interrupter and attach two of the clamps furnished. See Figure 3 (right). Securely tighten the clamp nuts.
- (h) Pull the cable taut at the coupling end of the interrupter and attach the other two clamps furnished. See Figure 3 (left). Securely tighten the clamp nuts.
- (i) Securely tighten the  $\frac{3}{8}$ "—16 zinc-plated serrated hex nuts that run the length of the container-halves.

**Step 3**

**For Model 2020 and Model 2025 Circuit-Switchers:**

Remove the high-voltage conductor from the upper terminal pad.

**For Model 2030 Circuit-Switchers:**

Remove the high-voltage conductors from the upper and lower terminal pads. Then remove the three  $\frac{1}{2}$ "—13 $\times$ 1 $\frac{1}{4}$ " hex-head stainless-steel cap screws and Belleville washers which are used to attach the upper terminal pad to the interrupter. Retain the upper terminal pad for re-use in Step 12. Now attach the spare interrupter lifting bracket, furnished with the replacement interrupter (in a separate box), using the hardware just removed. See Figure 4. Securely tighten the cap screws.

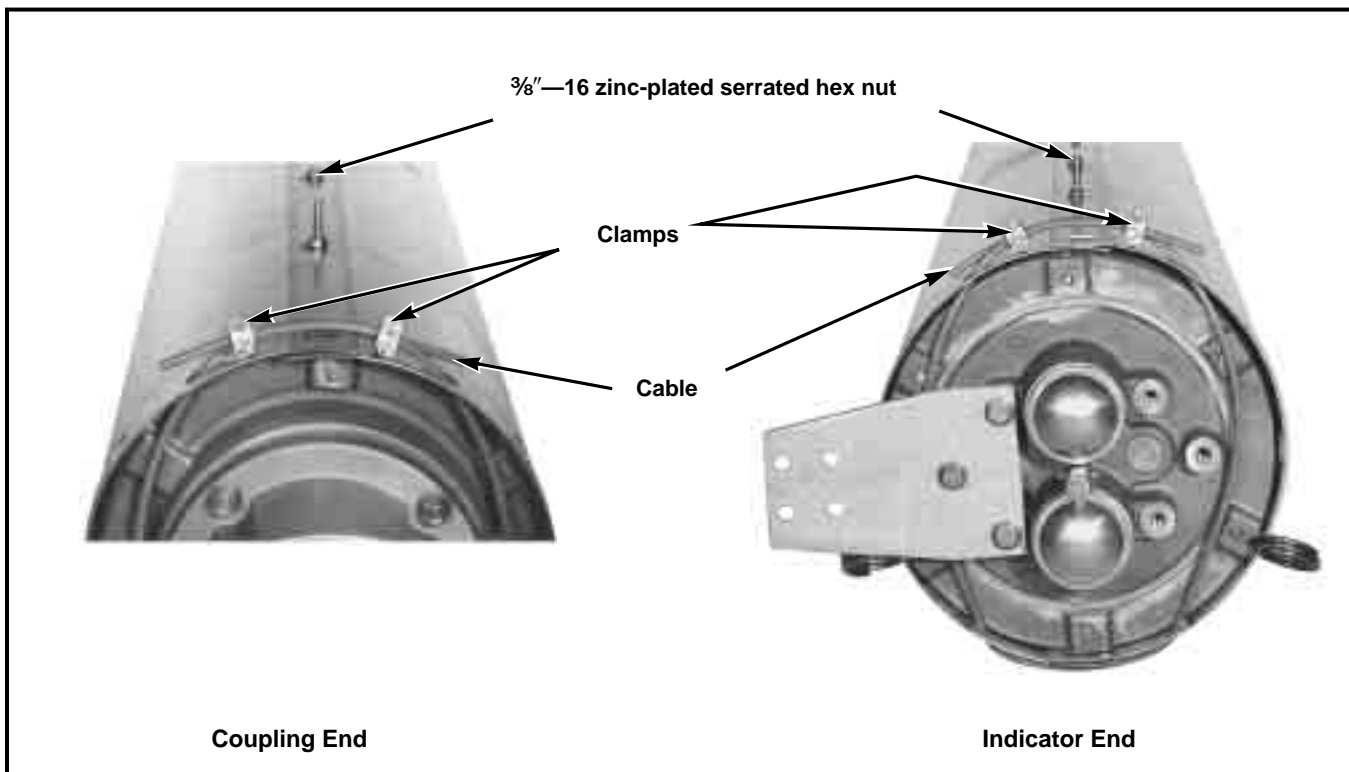

Figure 3. Attaching spare interrupter container on interrupter being replaced. Model 2030 Circuit-Switcher illustrated; Models 2020 and 2025 are similar. Model 2010, 2015, and 2040 interrupter is horizontal.

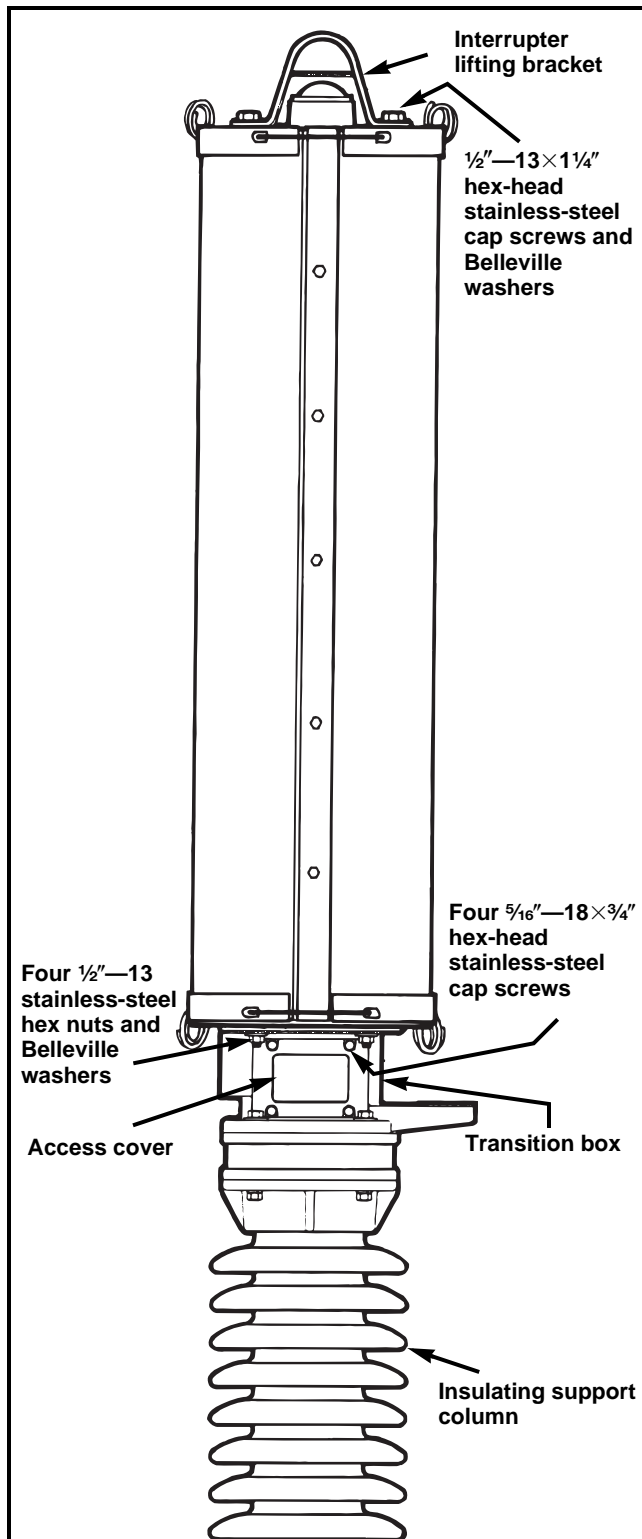

Figure 4. Removing access cover from transition box.

#### Step 4

Remove the four 5/16" — 18 × 3/4" hex-head stainless-steel cap screws used to attach the access cover to the side of the transition box on the insulating support column. See Figure 4. Remove the cover and place it and the hardware on a clean surface. They will be re-used in Step 11(f).

#### Step 5

Prepare the interrupter for removal from the insulating support column as follows. For Circuit-Switchers rated 69 kV through 138 kV, refer to Figure 5 (top); for Circuit-Switchers rated 161 kV and 230 kV, refer to Figure 5 (bottom).

- (a) Attach the spare stop bracket (marked with a black/yellow striped label) and spacer (marked with a black/yellow striped label) to the interrupter using the 5/16" — 18 × 2 1/4" hex-head stainless-steel screw furnished. (These items are included with the replacement interrupter, in a separate box.) Hand-tighten the screw.
- (b) Remove the pin retaining clip and connecting pin which attach the coupling to the operating rod link. Discard the connecting pin and pin retaining clip.
- (c) Now securely tighten the 5/16" — 18 × 2 1/4" hex-head stainless-steel screw.

#### Step 6

Attach a suitable lifting sling to the interrupter lifting bracket. Then remove the four 1/2" — 13 stainless-steel hex nuts and Belleville washers which attach the interrupter to the transition box on the insulating support column. See Figure 4. Retain this hardware for re-use in Step 11(c).

### CAUTION

Do not lift interrupter vertically by the lifting rings on the container.

#### Step 7

Carefully lift the interrupter from atop the transition box of its associated insulating support column and lower it to the ground. Place the interrupter on the ground horizontally. *Use care to avoid damaging the exposed coupling.*

**INTERRUPTER REPLACEMENT ON MODELS 2020, 2025, AND 2030 — Continued**

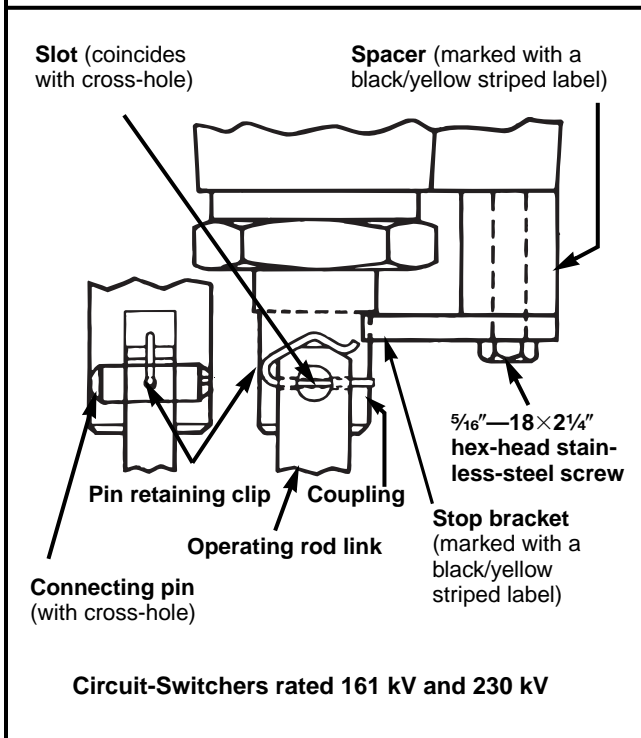
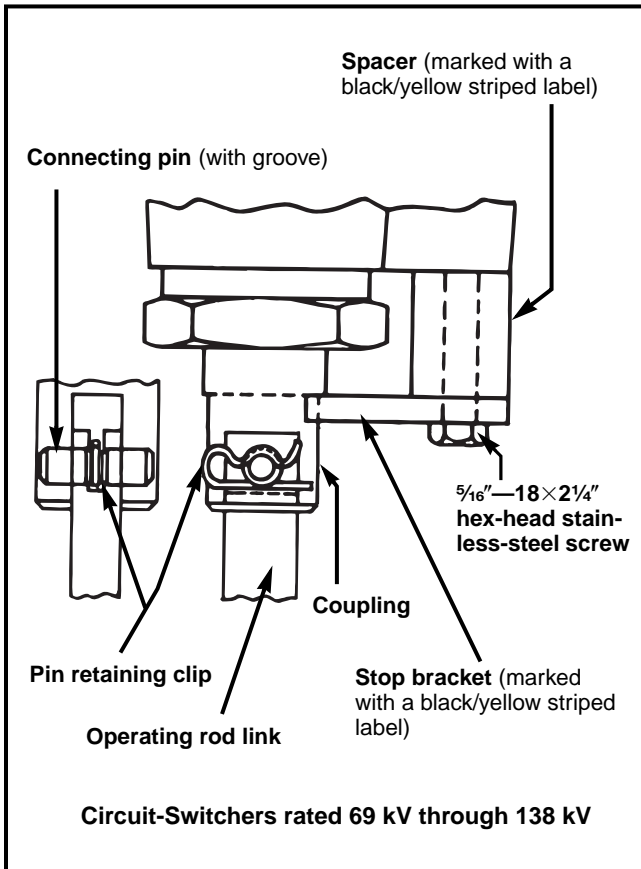

Figure 5. Disconnecting interrupter from operating rod link.

**Step 8**

Open the replacement interrupter shipping crate. Attach two suitable lifting slings to the replacement interrupter (the center of gravity is at approximately the center of the unit). See Figure 6. Then carefully remove the interrupter from the shipping crate and place it on the ground. Retain the shipping crate.

**CAUTION**

Do not remove the replacement interrupter bolted-on container until the installation has been completed.



Figure 6. Removing replacement interrupter from shipping crate.



**Step 9**

Attach a lifting sling to the lifting bracket on the replacement interrupter. Then carefully lift the interrupter somewhat higher than the top of the transition box on the insulating support column. *Use care to avoid damaging the exposed coupling.*

**Step 10**

Prepare the replacement interrupter for attachment to the insulating support column as follows:

- (a) Remove and discard the two #10-32 screws which connect the operating-rod holding bracket (marked with a black/yellow striped label) for shipment. See Figure 7 (left).

**NOTICE**

The operating rod is under pressure; when the two screws are removed, the holding bracket may move about ½ inch.

- (b) Pull the holding bracket to move the operating rod to its fully open position. See Figure 7 (right).
- (c) Remove the connecting pin and pin retaining clip used to attach the holding bracket to the coupling. Retain the connecting pin and pin retaining clip for re-use in Step 11(d), but discard the holding bracket.

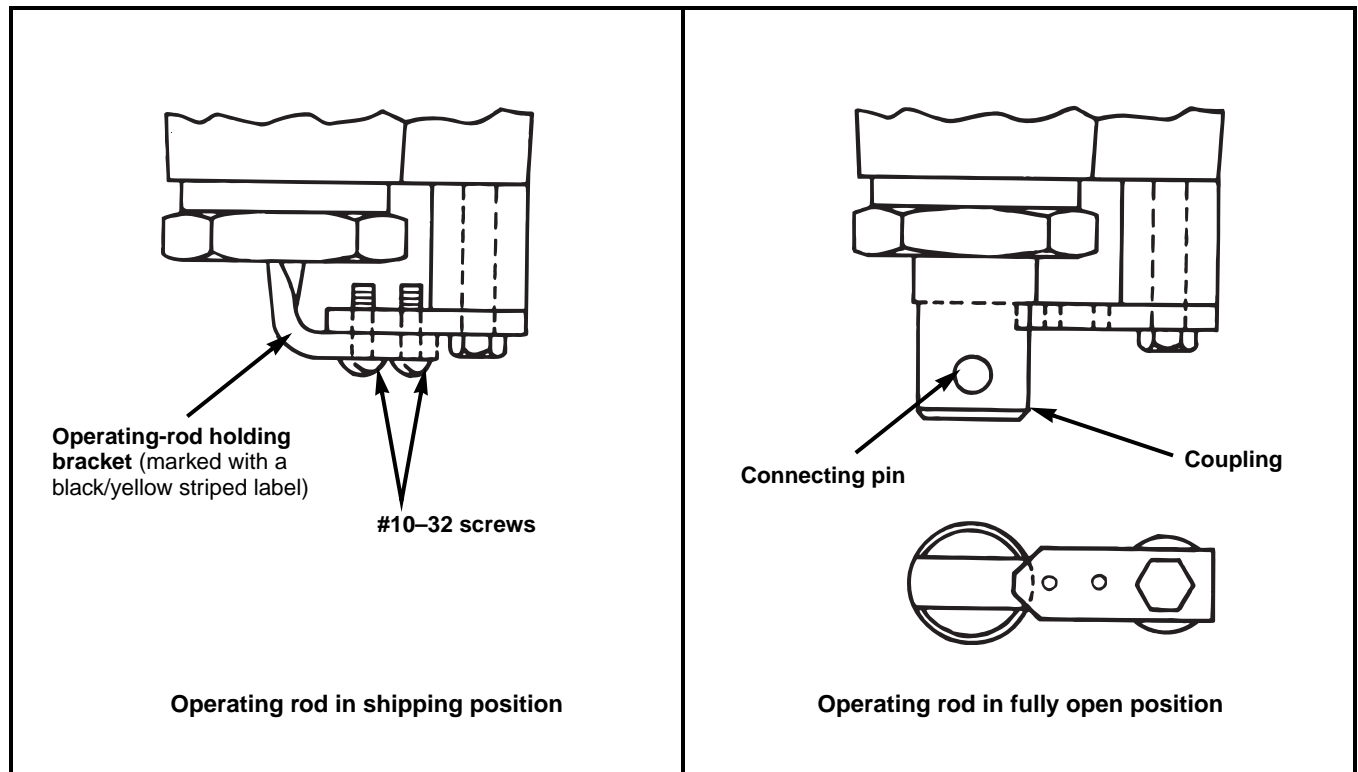

Figure 7. Preparing replacement interrupter for attachment to insulating support column.

**INTERRUPTER REPLACEMENT ON MODELS 2020, 2025, AND 2030 — Continued**

**Step 11**

For interrupters with the remote gas-density monitor option, see “Installing the Transmitter” on page 18.

Attach the replacement interrupter to the insulating support column as follows. See Figure 8.

- (a) Thoroughly wire-brush the top of the transition box and the mating surface on the interrupter, and immediately apply a liberal coating of Penetrox® A (available from Burndy Corporation) or other suitable aluminum connector compound to the brushed surfaces.
- (b) *Make certain that the positioning mark on the bottom of the interrupter is aligned with the positioning mark on the top of the transition box.* Then carefully lower the interrupter on top of the transition box. Note that one of the ½”—13 stainless-steel studs on the interrupter is longer than the other three, to aid in assembly.
- (c) Reattach a ½-inch Belleville washer and a ½”—13 stainless-steel hex nut, as retained from Step 6, to each of the four studs. Tighten each nut securely.

- (d) **For Circuit-Switchers rated 69 kV through 138 kV:** Insert the connecting pin retained from Step 10(c) into the coupling and operating rod link. See Figure 5 (top). *It will be necessary to loosen the 5/16”—18×2¼” hex-head stainless-steel screw indicated in Figure 5 (top) and withdraw it approximately 1/8 inch, so that the connecting pin can be inserted. Do not remove the screw at this time.* Now insert the pin retaining clip retained from Step 10(c) as indicated in Figure 5 (top). *Make sure that the clip is positioned as shown.*

**For Circuit-Switchers rated 161 kV and 230 kV:** Insert the connecting pin retained from Step 10(c) into the coupling and operating rod link. See Figure 5 (bottom). *It will be necessary to loosen the 5/16”—18×2¼” hex-head stainless-steel screw indicated in Figure 5 (bottom) and withdraw it approximately 1/8 inch, so that the connecting pin can be inserted. Do not remove the screw at this time.* Use a screwdriver blade in the slot at the end of the connecting pin to align the cross-hole in the connecting pin with the cross-hole in the operating rod link. Now insert the pin retaining clip retained from Step 10(c) as indicated in Figure 5 (bottom). *Make sure that the clip is positioned as shown.*

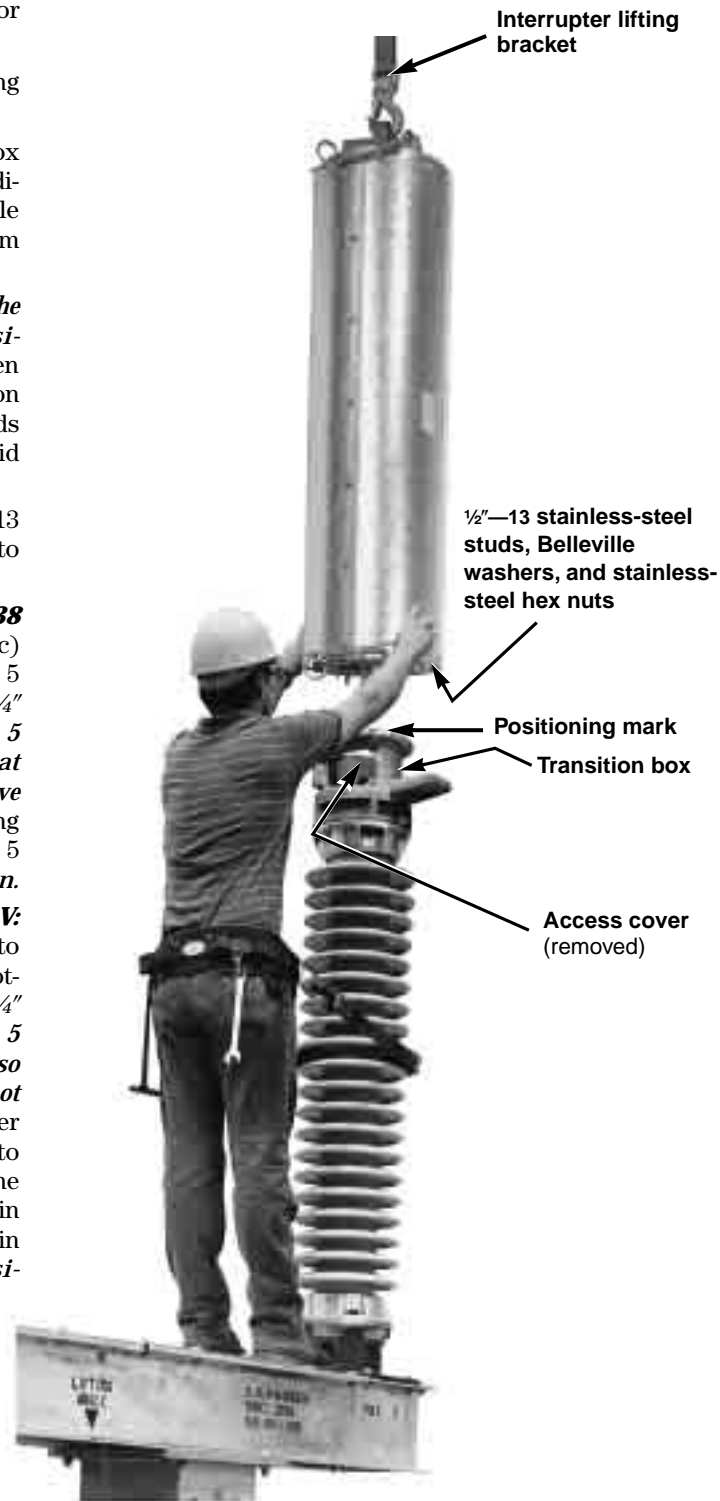

Figure 8. Attaching replacement interrupter to insulating support column. Model 2030 illustrated; Models 2020 and 2025 are similar.

- (e) Now remove and discard the  $\frac{5}{16}$ "— $18 \times 2\frac{1}{4}$ " hex-head stainless-steel screw, stop bracket (marked with a black/yellow striped label), and spacer (marked with a black/yellow striped label) illustrated in Figure 5.
- (f) Replace the access cover retained from Step 4 and securely tighten the associated  $\frac{5}{16}$ "— $18 \times \frac{3}{4}$ " hex-head stainless-steel cap screws.

**Step 12**

Remove the interrupter lifting bracket and associated  $\frac{1}{2}$ -inch stainless-steel hardware from atop the interrupter. Discard the lifting bracket but retain the hardware. Thoroughly wire-brush the indicator end casting where the terminal pad is to be attached, as well as the mating surface on the upper terminal pad, and immediately apply a liberal coating of Penetrox A or other suitable aluminum connector compound to the brushed surfaces. Then attach the upper terminal pad using three  $\frac{1}{2}$ "— $13 \times 1\frac{1}{4}$ " hex-head stainless-steel cap screws and Belleville washers. Reconnect the high-voltage conductor(s).

**Step 13**

Remove the container from the replacement interrupter as follows:

- (a) Remove and discard the  $\frac{3}{8}$ "—16 zinc-plated serrated hex nuts which run the length of the container.
- (b) Remove and discard the two  $\frac{3}{8}$ "— $16 \times 1$ " and two  $\frac{3}{8}$ "— $16 \times \frac{7}{8}$ " zinc-plated hex-head cap screws and flat washers which attach the two container-halves to the *coupling end casting* of the interrupter.
- (c) Remove and discard the two  $\frac{3}{8}$ "— $16 \times 1$ " and one  $\frac{3}{8}$ "— $16 \times \frac{7}{8}$ " zinc-plated hex-head cap screws and flat washers which attach *one* of the container-halves to the *indicator end casting* of the interrupter. Don't

remove the remaining  $\frac{3}{8}$ "— $16 \times \frac{7}{8}$ " cap screw—it's needed to temporarily retain the other container-half.

- (d) Pry the container-halves apart with a screwdriver. One of the container-halves can now be removed and discarded—slotted holes are provided so that a rope or lifting sling can be attached and the container-half more conveniently lowered to the ground.
- (e) Now remove and discard the remaining  $\frac{3}{8}$ "— $16 \times \frac{7}{8}$ " hex-head cap screw and flat washer which attach the other container-half. Then discard this container-half.
- (f) Finally, remove and discard the foam-core inner liner wrapped around the interrupter.

**Step 14**

Replace the trip-circuit and control-circuit fuseholders in the operator or—on newer operators—close the control-source disconnect switch and replace the motor-and-closing circuit fuseholder.

**Step 15**

Attach lifting slings to the four lifting rings on the replaced interrupter container. *Do not* loop slings from one end of the container to the other. Carefully lift the interrupter into the replacement interrupter shipping crate. Secure the interrupter and close the lid.

**Step 16**

Ship the replaced interrupter, transportation charges prepaid, to S&C Electric Company, Repair Center, 1800 Devon Avenue, Chicago, Illinois 60660-1010. To ensure proper handling, purchasers are asked to obtain from the nearest S&C Sales Office a special serially numbered label to place on the shipping crate. Please enclose a packing slip showing purchase order or requisition number covering the exchange.



**INTERRUPTER REPLACEMENT ON MODELS 2010, 2015, AND 2040**

**Step 17**

After following the user's standard procedures for clearing and tagging equipment on which work is to be performed, close the Circuit-Switcher by pressing the "CLOSE" push button on the operator.▲ Then remove the trip-circuit and control-circuit fuseholders or—on newer operators—open the control-source disconnect switch and remove the motor-and-closing circuit fuseholder from the operator. Push the manual trip lever counterclockwise to trip the interrupters. Do not replace the fuseholder(s) until so directed.

**NOTICE**

*Do not open the disconnect on Model 2010 Circuit-Switchers by means of the manual charging handle. The Series 2000 Circuit-Switcher Operator must remain discharged during the interrupter replacement procedure.*

**Step 18**

Install the spare interrupter container, furnished with the replacement interrupter, around the interrupter to be replaced, using the following procedure:



Figure 9. Raising spare interrupter container into position on interrupter being replaced. Model 2010 Circuit-Switcher illustrated; Models 2015 and 2040 are similar.

- (a) Remove the two container-halves from the shipping crate. Note that one of the container-halves is furnished with a loosely attached  $\frac{3}{8}$ "—16×2" carriage bolt at each end. Position this container-half so that the carriage-bolt threads protrude through the holes at the ends of the other container-half as shown in Figure 1.
- (b) Thread a  $\frac{3}{8}$ "—16 zinc-plated serrated hex nut on each of the two  $\frac{3}{8}$ "—16×2" carriage bolts. Tighten each hex nut just a few turns. See Figure 1.
- (c) Attach suitable lifting slings to the four lifting rings at the ends of the container-half assembly. See Figure 9. *Do not* loop slings from one end of the container to the other. Raise the container into position around the interrupter.
- (d) Using a screwdriver as necessary to spread the edges, snap the two halves together as shown in Figure 3. Place a  $\frac{3}{8}$ "—16 zinc-plated serrated hex nut on each of the captive  $\frac{3}{8}$ "—16× $\frac{3}{4}$ " carriage bolts that run the length of the container-halves. *Do not remove the lifting slings until the interrupter has been removed and lowered to the ground, as directed in Step 7.*
- (e) Attach the container-halves at the indicator end of the interrupter using one of the cables furnished. See Figure 3 (right). Thread the cable through adjacent holes in the container-halves, as shown. Position the cable around the indicator end casting, then thread the cable through adjacent holes in the container-halves, on the other side. *Do not attach clamps to the cable at this time.*
- (f) Attach the container-halves at the coupling end of the interrupter in a similar manner, using the other cable furnished. See Figure 3 (left). Slide the container-halves back or forth as necessary to allow the cable to be threaded through the holes.
- (g) Pull the cable taut at the indicator end of the interrupter and attach two of the clamps furnished. See Figure 3 (right). Securely tighten the clamp nuts.
- (h) Pull the cable taut at the coupling end of the interrupter and attach the other two clamps furnished. See Figure 3 (left). Securely tighten the clamp nuts.
- (i) Securely tighten the  $\frac{3}{8}$ "—16 zinc-plated serrated hex nuts that run the length of the container-halves.

**Step 19**

Remove the high-voltage conductor from the interrupter-end terminal pad and, on Model 2040 only, from the transition-box-end terminal pad. Then attach one of the

▲ Trip-close push buttons are not included on operators specified with catalog number suffix "J." In such instances, momentarily jumper terminals 1 and 3 to close the Circuit-Switcher.



## INTERRUPTER REPLACEMENT ON MODELS 2010, 2015, AND 2040 — Continued

shields for the interrupter pressure-relief device and low-gas-pressure indicator, furnished with the replacement interrupter (in a separate box), using two  $\frac{1}{2}$ "—13×1 $\frac{1}{4}$ " hex-head stainless-steel cap screws furnished. See Figure 11.

### Step 20

Remove the six  $\frac{5}{16}$ "—18× $\frac{3}{4}$ " hex-head stainless-steel cap screws used to attach the access cover to the side of the transition box on the insulating support column. See Figure 10. Remove the cover and place it and the hardware on a clean surface. They will be re-used in Step 31.

### Step 21

Prepare the interrupter for removal as follows. See Figure 10.

- (a) Attach the spare stop bracket (marked with a black/yellow striped label) and spacer (marked with a black/yellow striped label) to the interrupter using the  $\frac{5}{16}$ "—18×2 $\frac{1}{4}$ " hex-head stainless-steel screw fur-

nished. (These items are included with the replacement interrupter, in a separate box.) Hand-tighten the screw.

- (b) Remove the pin retaining clip and connecting pin which attach the coupling to the operating rod link. Discard the connecting pin and pin retaining clip.
- (c) Now securely tighten the  $\frac{5}{16}$ "—18×2 $\frac{1}{4}$ " hex-head stainless-steel screw.

### Step 22

Remove the four  $\frac{1}{2}$ "—13 stainless-steel hex nuts and Belleville washers which attach the interrupter to the transition box. Also remove the four  $\frac{1}{2}$ "—13×1 $\frac{1}{4}$ " hex-head galvanized steel cap screws and flat washers (for Circuit-Switchers rated 69 kV) or the four  $\frac{5}{8}$ "—11×1 $\frac{1}{4}$ " hex-head galvanized steel cap screws and flat washers (for Circuit-Switchers rated 115 kV through 230 kV) which are used to attach the terminal pad to the support insulator. See Figure 11. Retain the hardware in Step 29.

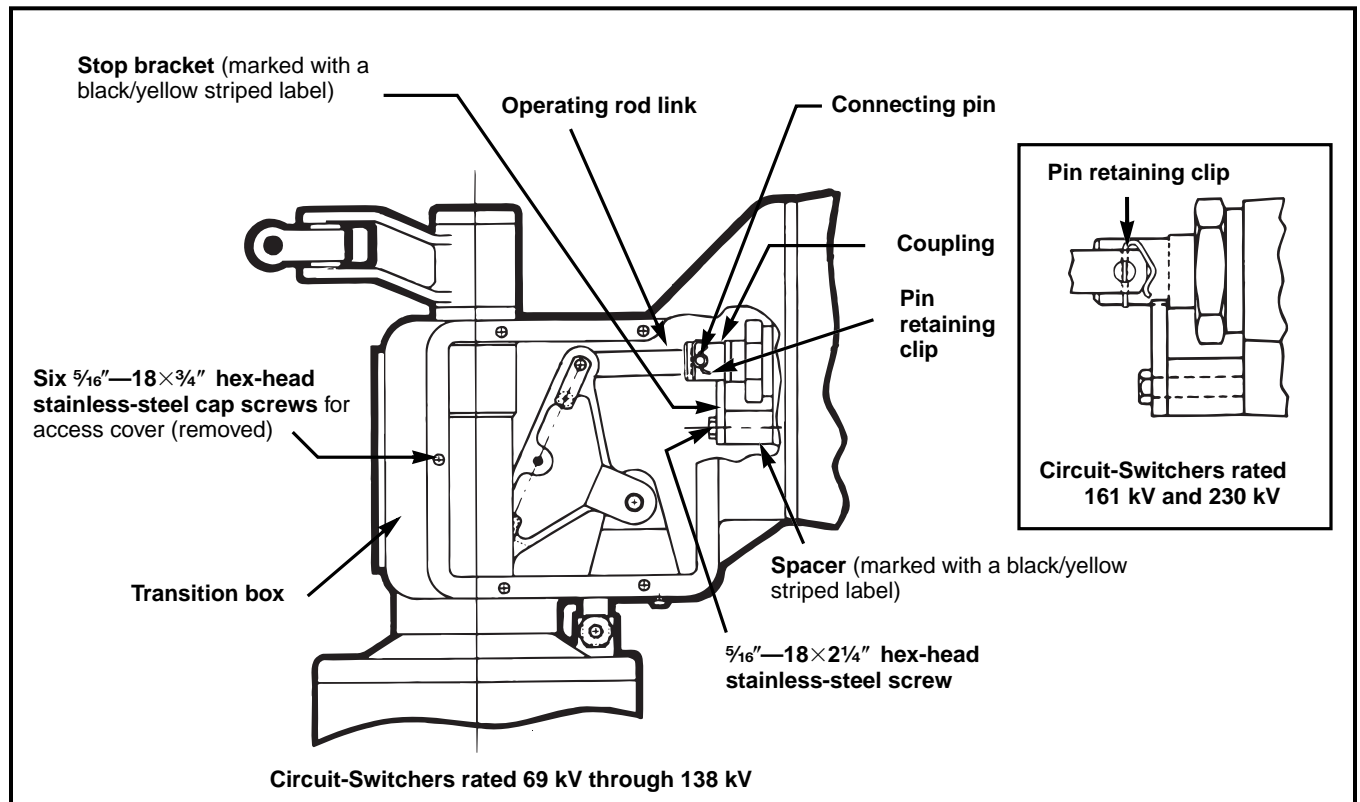

Figure 10. Transition box on Model 2010 and Model 2015 Series 2000 Circuit-Switchers rated 69 kV through 138 kV. Model 2040 is similar. Inset illustrates pin retaining clip used on Circuit-Switchers rated 161 kV and 230 kV.

**INTERRUPTER REPLACEMENT ON MODELS 2010, 2015, AND 2040 — Continued**

**Step 23**

With a moderate strain on the lifting slings, carefully slide the interrupter away from the transition box and lower it to the ground. *Use care to avoid damaging the exposed operating rod.*

**Step 24**

Remove the three 1/2"—13×1 1/4" hex-head stainless-steel cap screws and Belleville washers which are used to attach the terminal pad to the interrupter. Retain the terminal pad and hardware for re-use in Step 27.

**Step 25**

Open the replacement interrupter shipping crate. Attach two suitable lifting slings to the replacement interrupter (the center of gravity is at approximately the center of the unit). See Figure 6. Then carefully remove the interrupter from the shipping crate and place it on the ground. Retain the shipping crate.

**CAUTION**

Do not remove the replacement interrupter bolted-on container until the installation has been completed.

**Step 26**

Remove the interrupter lifting bracket and associated 1/2-inch stainless-steel hardware from the end of the replacement interrupter. (This bracket is not used in the interrupter replacement procedure for Model 2010, Model 2015, or Model 2040 Circuit-Switchers.) Attach the remaining shield for the interrupter pressure-relief device and low-gas-pressure indicator to the replacement interrupter, using two of the 1/2"—13×1 1/4" hex-head stainless-steel cap screws which were just removed. Discard the remaining screws.

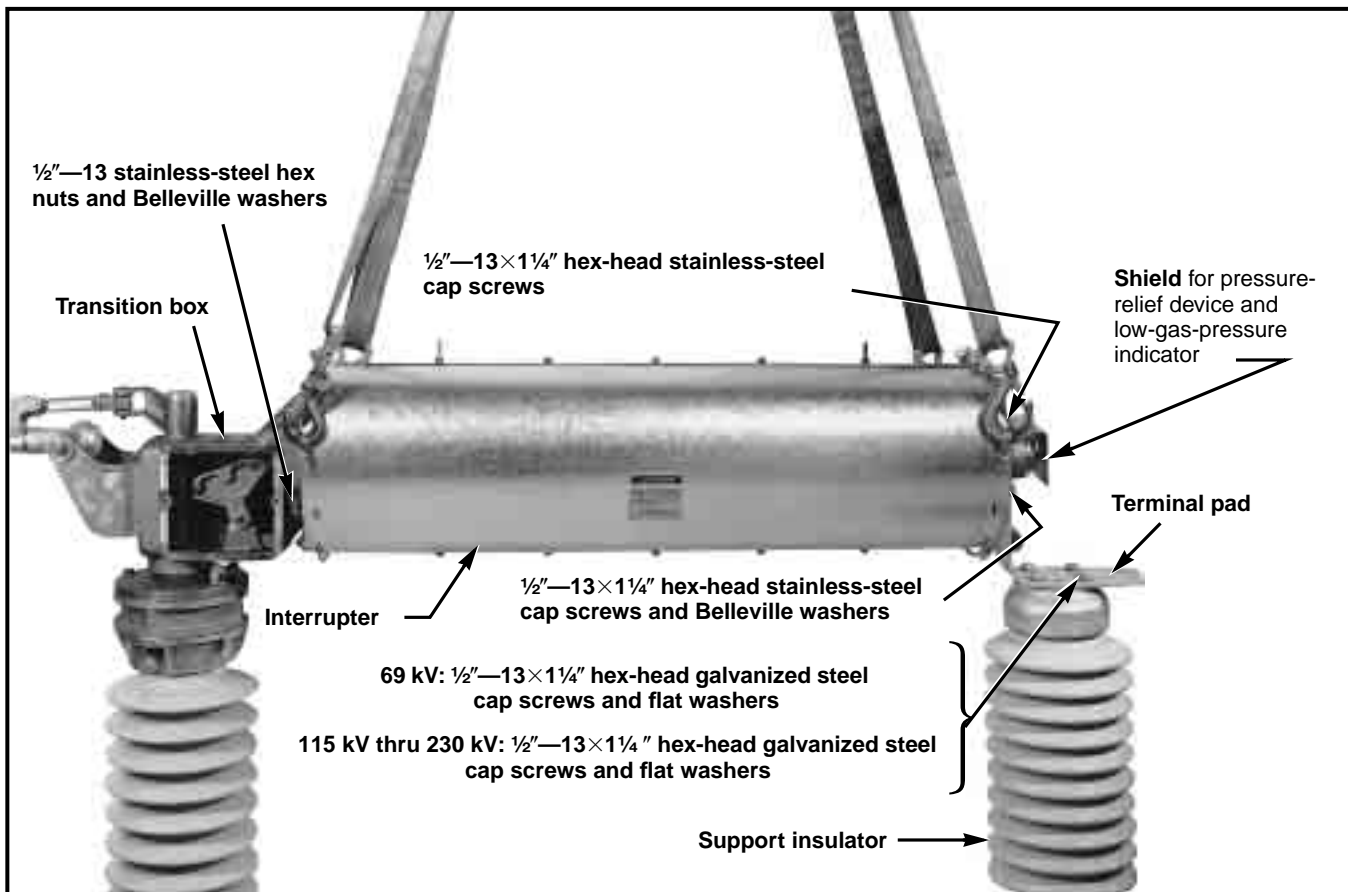

Figure 11. Removing interrupter from Model 2010 or Model 2015 Series 2000 Circuit-Switcher. Model 2040 is similar.



**Step 27**

Thoroughly wire-brush the indicator end casting of the replacement interrupter where the terminal pad is to be attached, as well as the mating surface on the terminal pad, and immediately apply a liberal coating of Penetrox A or other suitable aluminum connector compound to the brushed surfaces. Then loosely attach the terminal pad to the replacement interrupter using the three ½"–13×1¼" hex-head stainless-steel cap screws and Belleville washers retained from Step 24.

**Step 28**

Remove and discard the two #10–32 screws which connect the operating-rod holding bracket (marked with a black/yellow striped label) for shipment. See Figure 12 (left).

**NOTICE**

The operating rod is under pressure; when the two screws are removed, the holding bracket may move about ½ inch.

Pull the holding bracket to move the operating rod to its fully open position. See Figure 12 (right). Then remove

the connecting pin and pin retaining clip used to attach the holding bracket to the coupling. Retain the connecting pin and pin retaining clip for re-use in Step 30, but discard the holding bracket.

**Step 29**

Attach two suitable lifting slings to the replacement interrupter and carefully lift and slide the interrupter into position. *Use care to avoid damaging the exposed operating rod.*

Thoroughly wire-brush the mating surfaces on the transition box and replacement interrupter, and immediately apply a liberal coating of Penetrox A or other suitable aluminum connector compound to the brushed surfaces. Now attach the replacement interrupter to the transition box using the four ½"–13 stainless-steel hex nuts and Belleville washers retained from Step 22. Then attach the terminal pad to the support insulator using the four ½"–13×1¼" hex-head galvanized steel cap screws and flat washers (for Circuit-Switchers rated 69 kV) or the four ⅝"–11×1¼" hex-head galvanized steel cap screws and flat washers (for Circuit-Switchers rated 115 kV through 230 kV) retained from Step 22. Securely tighten all the hardware, including the cap screws used to attach the terminal pad to the replacement interrupter.

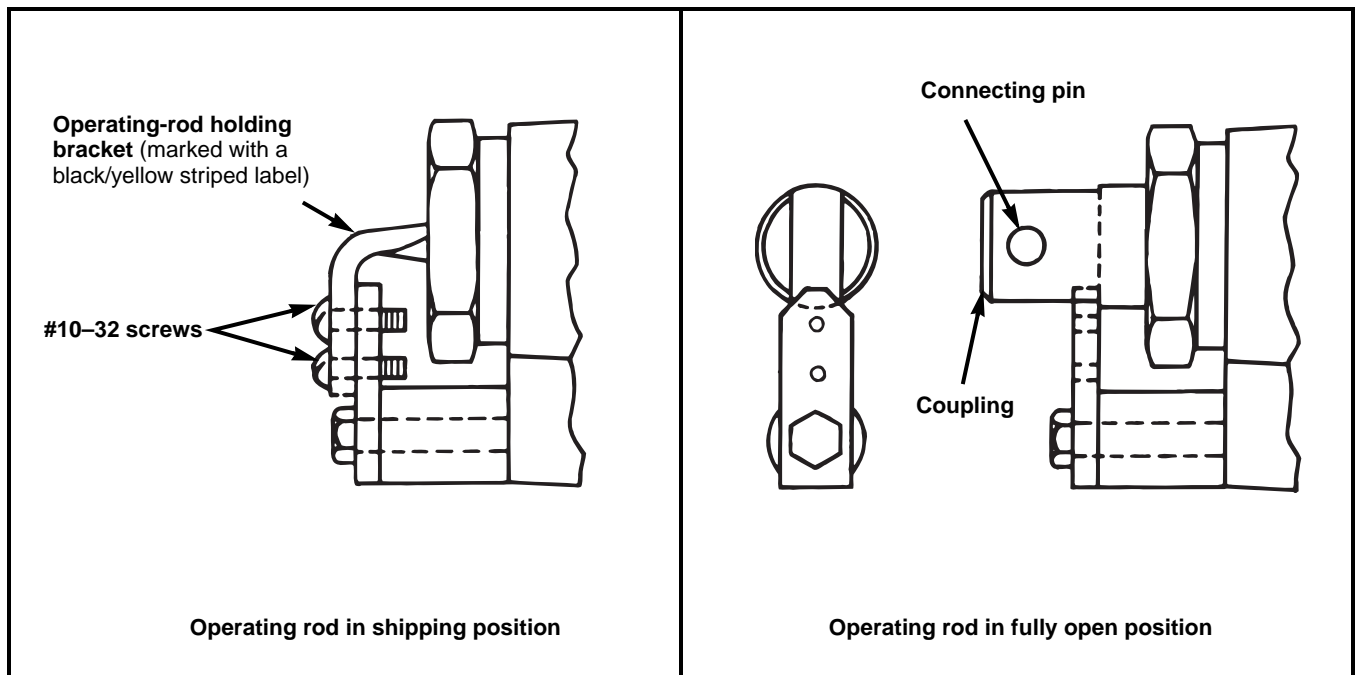

Figure 12. Preparing replacement interrupter for attachment to transition box.

**INTERRUPTER REPLACEMENT ON MODELS 2010, 2015, AND 2040 — Continued**

**Step 30**

For interrupters with the remote gas-density monitor option, see “Installing the Transmitter” on page 18.

**For Circuit-Switchers rated 69 kV through 138 kV:** Insert the connecting pin retained from Step 28 into the coupling and operating rod link. See Figure 13 (left). *It will be necessary to loosen the  $\frac{5}{16}$ "—18×2¼" hex-head stainless-steel screw indicated in Figure 13 (left) and withdraw it approximately ⅛ inch, so that the connecting pin can be inserted. Do not remove the screw at this time.* Now insert the pin retaining clip retained from Step 28 as indicated in Figure 13 (left). *Make sure that the clip is positioned as shown.* Finally, remove and discard the  $\frac{5}{16}$ "—18×2¼" hex-head stainless-steel screw, stop bracket (marked with a black/yellow striped label), and spacer (marked with a black/yellow striped label) illustrated in Figure 13 (left).

**For Circuit-Switchers rated 161 kV and 230 kV:** Insert the connecting pin retained from Step 28 into the coupling and operating rod link. See Figure 13 (right). *It will be necessary to loosen the  $\frac{5}{16}$ "—18×2¼" hex-head stainless-steel screw indicated in Figure 13 (right) and withdraw it approximately ⅛ inch, so that the connecting pin can be inserted. Do not remove the screw at this time.* Use a screwdriver blade in the slot at the end of the connecting pin to align the cross-hole in the connecting pin with the cross-hole in the operating rod link. Now insert the pin retaining clip retained from Step 28 as indicated in Figure 13 (right). *Make sure that the clip is positioned as shown.* Finally, remove and discard the  $\frac{5}{16}$ "—18×2¼" hex-head stainless-steel screw, stop bracket (marked with a black/yellow striped label), and spacer (marked with a black/yellow striped label) illustrated in Figure 13 (right).

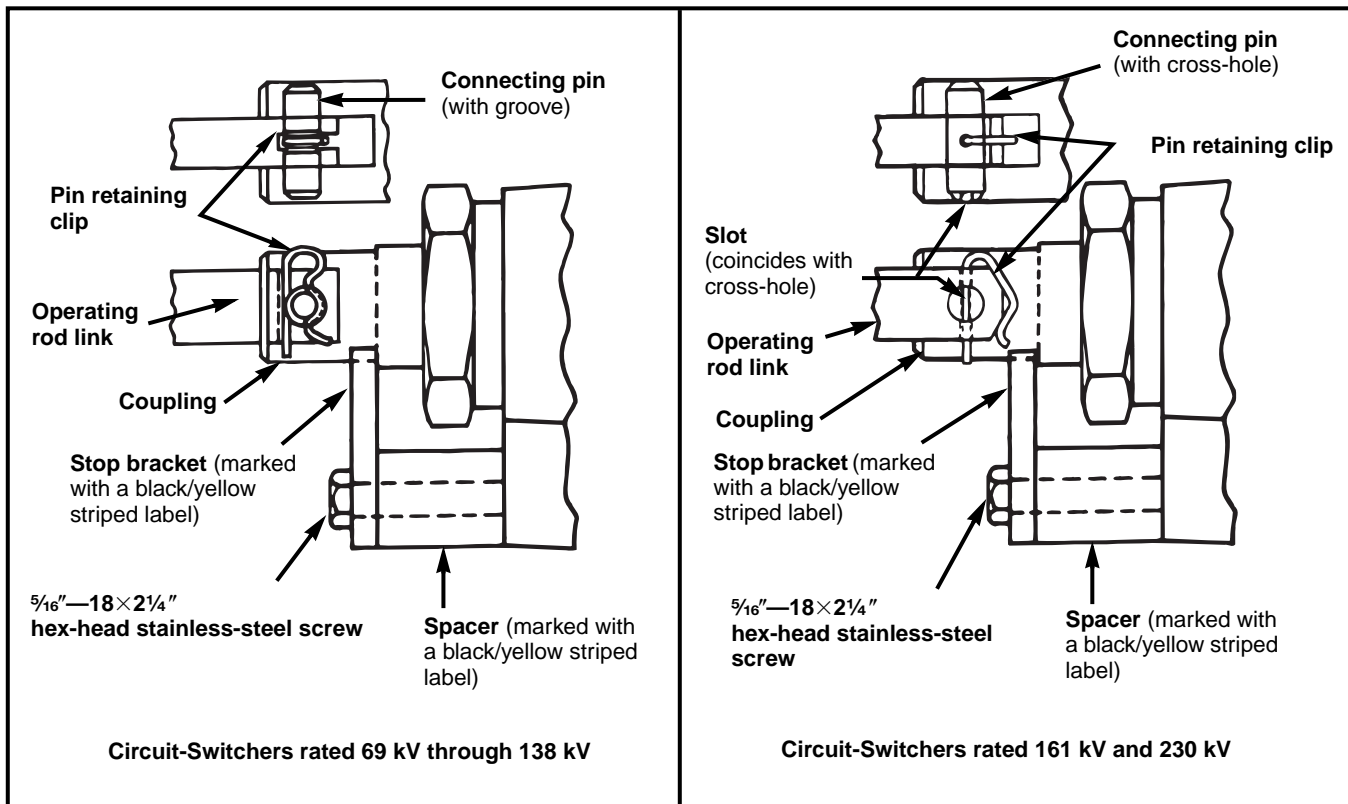

Figure 13. Coupling replacement interrupter.

**Step 31**

Replace the access cover retained from Step 20 and securely tighten the associated  $\frac{5}{16}$ "— $18 \times \frac{3}{4}$ " hex-head stainless-steel cap screws.

**Step 32**

Remove the shield for the pressure-relief device and low-gas-pressure indicator from the replacement interrupter. Discard the shield and its hardware. Reconnect the high-voltage conductor to the interrupter-end terminal pad and, on Model 2040, to the transition-box-end terminal pad.

**Step 33**

Remove the container from the replacement interrupter as follows:

- (a) Remove and discard the  $\frac{3}{8}$ "—16 zinc-plated serrated hex nuts which run the length of the container.
- (b) Remove and discard the  $\frac{3}{8}$ "— $16 \times \frac{7}{8}$ " and two  $\frac{3}{8}$ "— $16 \times 1$ " zinc-plated hex-head cap screws and flat washers which attach the *upper* container-half to the coupling end casting of the interrupter. Also remove and discard the  $\frac{3}{8}$ "— $16 \times \frac{7}{8}$ " and two  $\frac{3}{8}$ "— $16 \times 1$ " zinc-plated hex-head cap screws and flat washers which attach the upper container-half to the indicator end casting of the interrupter.
- (c) Pry the container-halves apart with a screwdriver. The upper container-half can now be removed and discarded—slotted holes are provided so that a rope or lifting sling can be attached and the container-half more conveniently lowered to the ground.
- (d) Now remove and discard the  $\frac{3}{8}$ "— $16 \times \frac{7}{8}$ " hex-head cap screw and flat washer which attach the *lower* con-

tainer-half to the coupling end casting of the interrupter, and the  $\frac{3}{8}$ "— $16 \times \frac{7}{8}$ " hex-head cap screw and flat washer which attach the lower container-half to the indicator end casting of the interrupter. Then discard this container-half.

- (e) Finally, remove and discard the foam-core inner liner wrapped around the interrupter.

**Step 34**

Replace the trip-circuit and control-circuit fuseholders in the operator or—on newer operators—close the control-source disconnect switch and replace the motor-and-closing circuit fuseholder.

**Step 35**

Attach lifting slings to the four lifting rings on the replaced interrupter container. *Do not* loop slings from one end of the container to the other. Carefully lift the interrupter into the replacement interrupter shipping crate. Secure the interrupter and close the lid.

**Step 36**

Ship the replaced interrupter, transportation charges prepaid, to S&C Electric Company, Repair Center, 1800 Devon Avenue, Chicago, Illinois 60660-1010. To ensure proper handling, purchasers are asked to obtain from the nearest S&C Sales Office a special serially numbered label to place on the shipping crate. Please enclose a packing slip showing purchase order or requisition number covering the exchange.



**INTERRUPTERS WITH THE REMOTE GAS-DENSITY MONITOR OPTION**

**Installing the Transmitter**

When replacing an interrupter on Series 2000 Circuit-Switchers with the remote gas-density monitor option, the transmitter must also be replaced. Following are the replacement and setup instructions for the remote gas-density monitor transmitter. For installation and operating instructions for remote gas-density monitors in new Circuit-Switcher installations, refer to Instruction Sheet 716-530, "S&C Series 2000 Circuit-Switchers: Remote Gas-Density Monitor."

**Step 37**

Before mounting the replacement interrupter to its associated transition box, locate the red sensor cable on the base of the interrupter. Cut and remove the wire ties and the wire tie mounts securing the sensor cable, taking care not to damage the cable. Do not remove the shorting plug from the end of the green 6-pin connector at this time. See Figure 14.

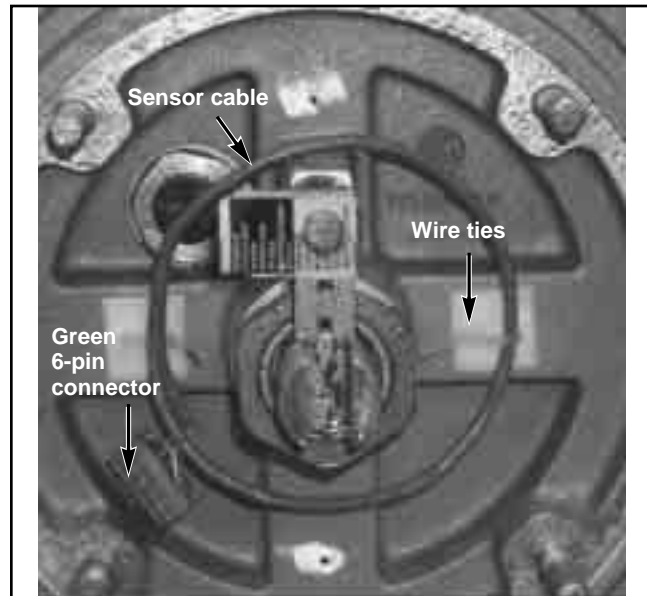

Figure 14. Location of sensor cable.

**CAUTION**

*Exercise care* when mounting the interrupter to the transition box. The sensor cable is factory-installed on the interrupter and cannot be replaced in the field if damaged. **Damage to the cable will necessitate returning the interrupter and transmitter to the factory for replacement and recalibration.**

**Step 38**

On Circuit-Switchers with vertical interrupters (Model 2020, Model 2025, and Model 2030), the transmitter is mounted in place of the transition box access cover. Remove the four  $\frac{5}{16}$ "— $18 \times \frac{3}{4}$ " socket-head cap screws and flat washers that secure the transmitter to the transition box. Reserve the mounting hardware and set the replaced transmitter aside in a protected area. See Figure 15.

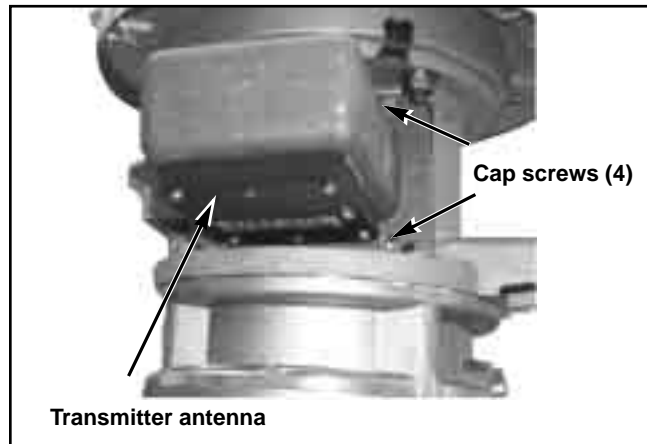

Figure 15. Transmitter mounted on transition box with antenna facing the ground. Remove the existing transmitter, and return it with the replaced interrupter.

On Circuit-Switchers with horizontal interrupters (Model 2010, Model 2015, and Model 2040), the transmitter is mounted on an adapter panel. The adapter panel is mounted in place of the transition box access cover. Remove the six stainless-steel  $\frac{5}{16}$ "— $18 \times \frac{3}{4}$ " hex-head cap screws that secure the adapter panel to the transition box. Then remove the four  $\frac{5}{16}$ "— $18 \times \frac{3}{4}$ " cap screws and ESNA nuts that secure the transmitter to the adapter panel. Install the replacement transmitter into the adapter panel. Save the adapter panel mounting hardware and set the replacement transmitter aside in a protected area. Save the replaced transmitter and return it to S&C Electric Company with the replaced interrupter. See Step 36 on page 11 for details.

**NOTICE**

Each transmitter is factory-calibrated to the interrupter with which it is shipped, and must be installed on its associated interrupter. The serial number associated with the interrupter matches the serial number stamped on the transmitter. **Failure to keep transmitters with their associated interrupters can cause the remote gas-density monitoring system to malfunction.**

**Step 39**

Before coupling the replacement interrupter to the operating rod, feed the sensor cable into the top of the transition box. Make sure the cable is fed through the transition box on the side of the operating rod that is towards the access opening. Feeding the sensor cable from behind the operating rod may cause the cable to catch on the rod during switch operation. See Figure 16.

**NOTICE**

Make sure the sensor cable is not caught on the Circuit-Switcher operating rod. **Failure to do so can cause the remote gas-density monitoring system to malfunction.**

**Step 40**

Mount the replacement interrupter and couple it to the operating rod, as directed in the instructions for your model of Circuit-Switcher.

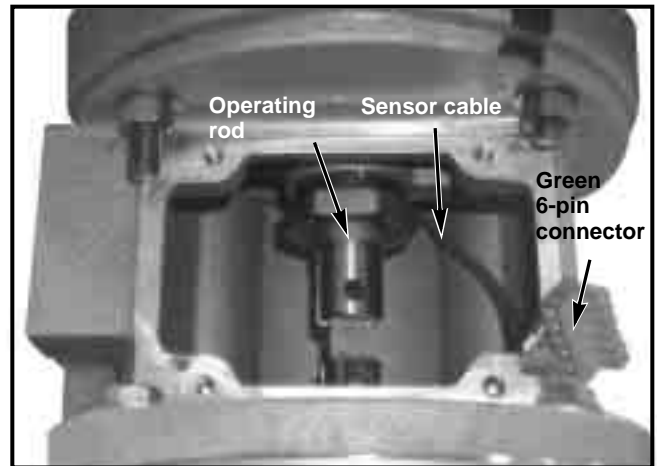

Figure 16. Inside of transition box showing sensor cable. Feed the cable through the transition box towards the front, to avoid snagging on the operating rod.

**INTERRUPTERS WITH THE REMOTE GAS-DENSITY MONITOR OPTION — Continued**

**Step 41**

Ground the transmitter to the transition box with the supplied grounding strap. Clamp one end of the grounding strap to the bottom of the transmitter housing, and the other to the transition box. See Figure 17.

**NOTICE**

Make sure the transmitter is fully grounded before connecting the battery or sensor cables. **Static and/or electrical discharge from the interrupter can damage the transmitter circuit board and sensor cable.**

**Step 42**

With the transmitter and transition box grounded, firmly plug the black, 2-pin connector from the battery into the black 2-pin socket on the transmitter circuit board. When properly installed, the locking tab on the connector will face away from the battery. See Figure 18.

**Step 43**

Remove the shorting plug from the green 6-pin connector located on the red sensor cable. Remove the shorting plug from the 6-pin socket on the transmitter circuit board. Firmly plug the green 6-pin connector from the interrupter into the green 6-pin socket on the transmitter circuit board. See Figure 18.

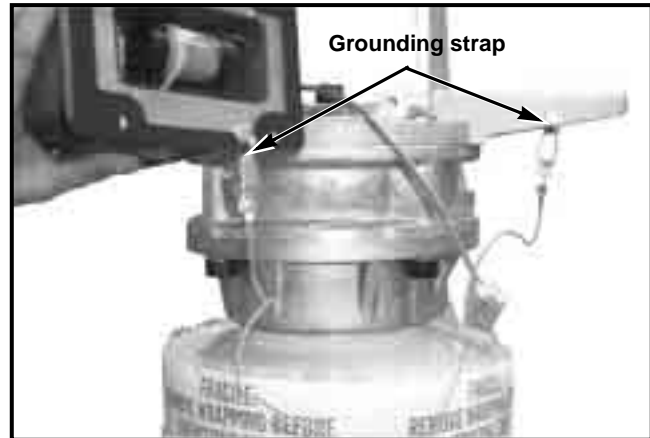

Figure 17. Attach one end of the grounding strap to the transmitter housing, and the other end to the transition box.

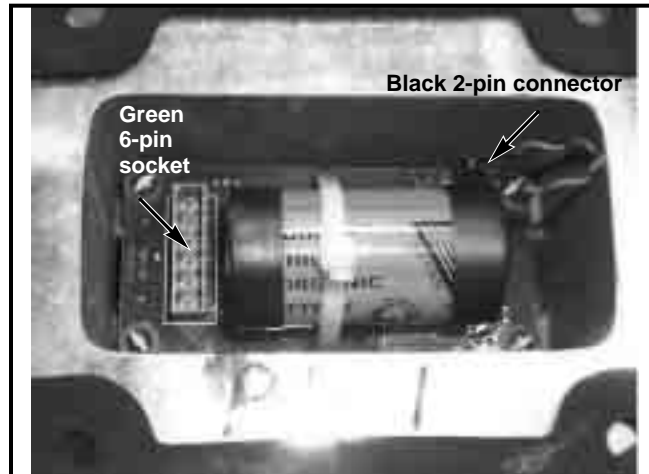

Figure 18. Plug the black 2-pin connector from the battery into the black 2-pin socket on the transmitter circuit board. Plug the green 6-pin connector from the interrupter into the green 6-pin socket on the circuit board.

**Step 44**

Using the mounting hardware saved from Step 38, reattach the transmitter to the transition box, making sure that the black antenna cover faces the ground. See Figure 19. Repeat Steps 37 through 44 for each interrupter to be replaced. Retain the jumper for future use, in the pocket on the operator enclosure door.

**NOTICE**

Save the shorting plugs, and install them on the replaced interrupters. When replacing an interrupter with the remote gas-density monitor option, ship the replaced transmitter to S&C Electric Company along with the replaced interrupter.



Figure 19. Reattach the transmitter to the transition box after making the battery and sensor cable connections.



**INTERRUPTERS WITH THE REMOTE GAS-DENSITY MONITOR OPTION — Continued****Programming the Receiver**

After replacing an interrupter and transmitter, the remote gas-density monitoring system must be reprogrammed. Programming “teaches” the receiver which transmitter radio signal corresponds to which interrupter.

A series of prompts on the LCD will guide you through the programming process.

**NOTICE**

All phases must be reprogrammed when an interrupter is replaced.

**Step 45**

Attach the magnet tool to a hotstick long enough to reach the transmitter. The magnet tool, furnished with the original switch, is located on the inside of the switch operator door.

**Step 46**

Press—and hold for 10 seconds—the system set-up button located on the right side of the receiver. See Figure 20. The receiver unit will start to count down. See Figure 21. Release the set-up button when prompted. See Figure 22. This will put the receiver in setup mode.

**NOTICE**

Inadvertently releasing the set-up button during countdown will stop set-up and reset the receiver in regular monitoring mode.

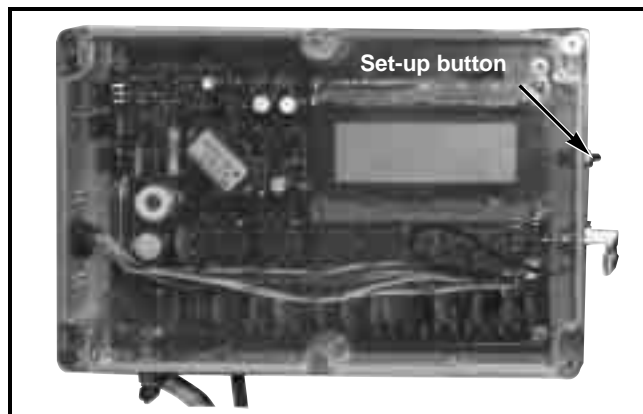

Figure 20. Location of set-up button on receiver.

<b>A [DENS]</b>	<b>100%</b>
<b>B [DENS]</b>	<b>100%</b>
<b>C [DENS]</b>	<b>100%</b>
<b>SETUP IN 10 SECONDS</b>	

Figure 21. Receiver LCD while pressing and holding set-up button.

**S&C RGDM Setup Mode  
Used To Link Remotes  
To Phases. To Start  
Press Button & Hold**

Figure 22. Receiver LCD during start of set-up mode.

**Step 47**

Press—and hold for 5 seconds—the sytem set-up button. The A-phase set-up prompt will be displayed. See Figure 23.

**Step 48**

To initialize A-Phase, press and release the set-up button again. Then position and hold the magnet tool flush against the side of the transmitter as shown in Figure 24. Make sure that the two poles of the magnet are aligned vertically. When the receiver starts counting signals from the transmitter, remove the magnet tool. See Figure 25.

When the magnet tool is applied correctly, the receiver will display the serial number of the interrupter/transmitter—after 10 rapid signals are detected, the display will prompt you to move on to B-Phase, and then C-phase. Repeat Step 48 for B-phase and then again for C-phase. See Figures 25 and 26.

**NOTICE**

During normal operation, the transmitter sends a signal to the receiver antenna once every hour. When the magnet tool is applied to transmitter, the transmitter is prompted to send a signal to the receiver once every second. The transmitter will continue to send this signal for up to 10 seconds after the magnet tool is removed.

The system will assign phase designations in the order in which the phases are initialized. The first phase initialized will be assigned the letter “A,” the second “B,” and the third “C.” Make sure that the phases are initialized in the order appropriate for the installation.

Store the magnet tool inside the switch operator door for future use.

**S&C RGDM A-Phase Set Up. Use Magnet To Start A-Phase Remote. Press Button To Go**

Figure 23. Receiver LCD prompt for magnet tool.

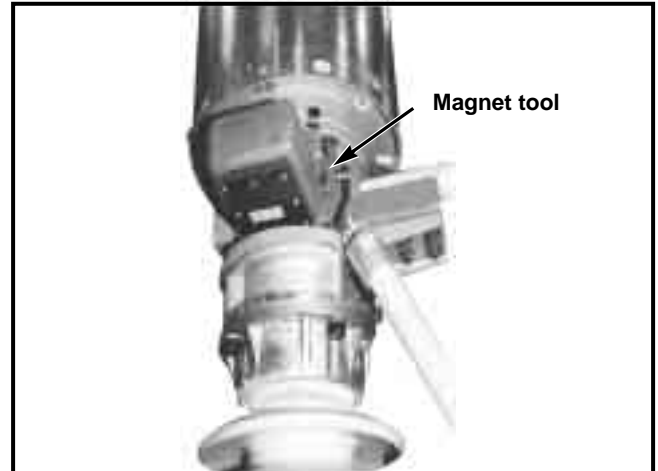

Figure 24. Position of magnet tool. Place magnet tool flush against the side of the transmitter with the serial number stamping.

**S&C RGDM “A” Phase  
SS-0608-001 : 9**

Figure 25. Receiver LCD counting transmissions from transmitter box.

**Got 10 Packets From  
SS-0608-001  
Which Is Phase “A”**

Figure 26. Receiver LCD after receiving 10 signals from transmitter.



**INTERRUPTERS WITH THE REMOTE GAS-DENSITY MONITOR OPTION — Continued**

**Step 49**

After all three phases are initialized, the LCD will show the three interrupter serial numbers in the order the phases were initialized. The display will sequentially alternate the messages shown in Figures 27a, 27b, and 27c. Hold down the set-up button for 5 seconds. This will clear the previous settings from the receiver and save the new settings. When the update has been completed, the LCD will display a “Release Button” prompt. Release the set-up button. The receiver will reboot.

**NOTICE**

If the poles are not initialized in the correct sequence, wait for the receiver to time out and reboot. (Approximately 2 minutes.) Disconnecting power to the operator during set-up will also reboot the system.

After programming is complete, the display **will not** indicate which interrupter/transmitter serial number is associated with each phase again. Please make a note of which interrupter/transmitter serial number is associated with each phase for future reference.

**Step 50**

Test the system by attaching the magnet tool to a hotstick long enough to reach the transmitter. Hold the magnet tool flush against the side of the transmitter as shown in Figure 24. Repeat for each transmitter. Gas-density data will be transmitted to the receiver and shown on the LCD.

**Step 51**

Check the pole-unit designations on the LCD, and that the gas-density readings for all three phases are at 100%. If so, installation is complete. If the pole-unit designations are not correct, reprogramming of the receiver is required. Repeat Steps 41–51 until the pole-unit designations are appropriate for the installation.

**Check Serial Numbers**

**SS-0608-001**

**SS-0608-002**

**SS-0608-003**

Figure 27a. Receiver LCD after all three phases are initialized.

**If Serial Numbers  
Are Correct Press &  
Hold to Save Them**

Figure 27b. Receiver LCD after all three phases are initialized.

**If Serial Numbers  
Are Wrong, Wait For  
Receiver To Reset  
And Do Setup Again.**

Figure 27c. Receiver LCD after all three phases are initialized.

**INSPECTION SCHEDULE AND PROCEDURES**

To ensure Series 2000 Circuit-Switcher’s continued proper performance, it should be inspected in accordance with S&C’s recommended schedule and procedures contained in S&C Instruction Sheet 716-590.

